

# Heavy-duty power supply regulates either voltage, current or power

*By combining switching and series-pass techniques, this high-voltage supply's designer achieved 0.01% regulation at power levels to 100W.*

**James M. Williams**, Teledyne Philbrick

Regulated high-voltage power supplies, while common, generally offer only constant-current and constant-voltage modes of operation. This one adds a constant-power (EI product) mode.

Careful circuit design permitted fitting the unit's 100W capability into an unventilated rack-mount chassis measuring only 3-1/2×14×19 inches. Also, no high-voltage semiconductors (except diodes) are employed in it. Voltage output is 50 to 1000V at up to 100W, with better than 0.01% regulation. In the current mode, the unit delivers a maximum of 100 mA with 0.01% stability. Finally, when regulating power (EI), the output supplies up to 100W with 0.01% stability.

## Regulator + converter = amplifier

Both switching and series-pass regulation techniques are used (Fig. 1). The instrument functions by controlling the input power to a toroidal dc-to-dc inverter with a FET-input operational (servo) amplifier. One of the amplifier's inputs is referenced to a precision variable voltage. The other input is connected, through suitable circuitry, to the rectified and filtered output of the inverter.

Considered as a unit, the pass regulator and converter function as an amplifier within the servo amplifier's feedback loop. When feedback is taken from the "voltage sense" network, a constant-voltage output is produced. Taking it from the "current sense" network results in a constant current through the load. Lastly, when inputs from the voltage-sensing and current-sensing networks are multiplied by the multiplier circuitry, the load receives constant power.

The pre-chopper maintains a small fixed voltage across the pass regulator regardless of inverter output setting. It does this by synchronously chopping the 120-Hz peaks from a full-wave rectifier in a manner similar to a lamp dimmer. This limits the pass regulator dissipation to an acceptable level. Had it not been done, dissipation would have been excessive, especially at low-voltage output settings.

Crowbarring prevents overload by shutting down the supply when it senses either too much current flowing in the load or a load dropout.

## A Cook's tour of the circuit

Details of the circuit will now be discussed with

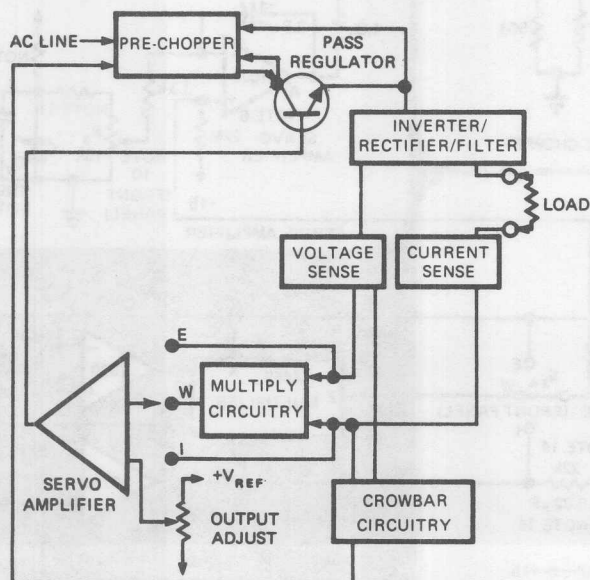
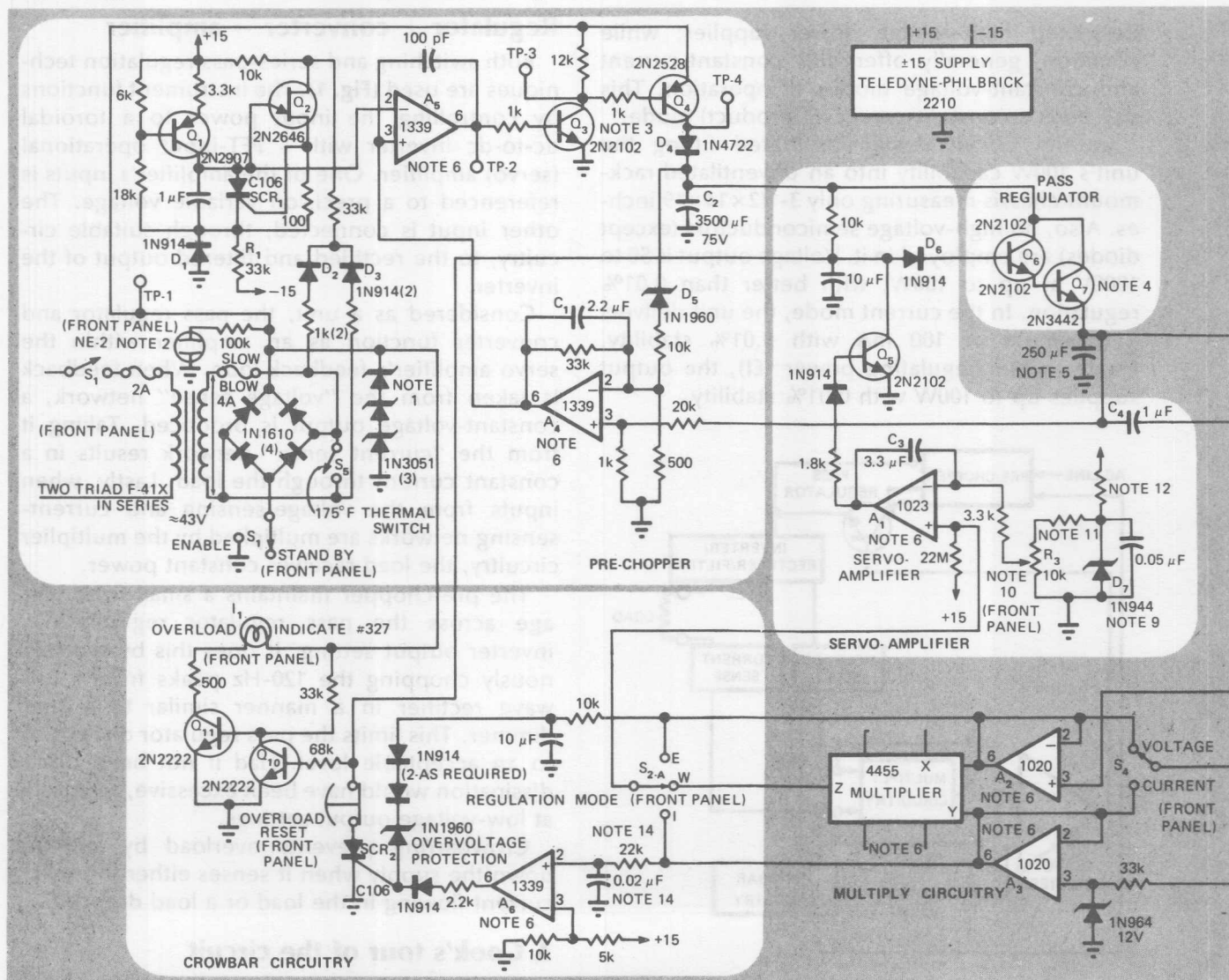
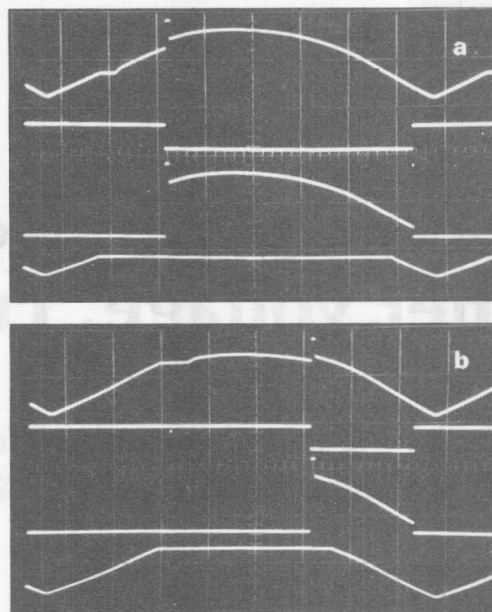

Fig. 1—Functional diagram of the 3-mode HV power supply.

the aid of a detailed schematic (Fig. 2). Looking at the SERVO AMPLIFIER section, reference stability results from using a 1N944B temperature-compensated zener diode ( $D_7$ ) with its output scaled to 10:000V across the Kelvin-Varley potentiometer. The potentiometer's output biases the 1023 FET amplifier  $A_1$ , which functions as a precision servo amplifier. Its 20-pA bias current insures negligible loading error on the potentiometer.  $A_1$ 's output drives the  $Q_6/Q_7$  pair, a 2N2102 - 2N3442 Darlington pass regulator, via the 2N2102 pull-down transistor  $Q_5$ .  $Q_7$ 's collector is supplied dc power from the output of the pre-chopper, which will be described later.  $Q_7$ 's emitter drives the toroid transformer,  $T_1$ .

The wide dynamic range of the inverter is due to the 2N2528 transistors ( $Q_8, Q_9$ ) that feature low saturation voltages, good beta linearity and reasonable speed. They permit the inverter to run at low output voltages with no resultant sacrifice in performance at high output potentials. Output of the transformer is rectified by a full-wave bridge employing two 1N5061's in each leg. The stacking



◀ **Fig. 3—Pre-chopper waveforms** at 4.2W output (a), and 42W output (b) (taken with a 15 kΩ load on the supply output). Scope traces shown are at 50V/div. and 1 msec/div. In each picture the top waveform, taken at TP<sub>1</sub>, shows the 120-Hz output of the full-wave bridge. Note the spike created by flyback effect in the power transformer when the pre-chopper allows it to “let go.” Spike amplitude would normally be about 150V, but the series string of three 30V zeners (1N3051) clips it to 90V. The second waveform, present at TP<sub>2</sub>, is that at the output of pulse-width modulator A<sub>5</sub>. The third waveform, taken at Q<sub>3</sub>'s collector (TP<sub>3</sub>), shows how much of the 120-Hz waveform is not being utilized. At the bottom is the waveform present at TP<sub>4</sub>. The 1N4722 diode (D<sub>4</sub>) prevents Q<sub>4</sub> from becoming reverse biased when the dc voltage on C<sub>2</sub> is greater than that on Q<sub>4</sub>'s emitter.

allows use of diodes rated at only 800V. Filtering, provided by the 1-μF capacitor, is adequate for the square-wave output.

### Higher is better

Voltage feedback is derived by a 99 to 1 division of the filtered output. The current-feedback signal, on the other hand, is split into four separate switch-selectable ranges. This promotes ease of setting and keeps the current-feedback signal at high levels—and therefore easy to work with. The “shorting-switch” selection scheme insures feedback even during the switching operation.

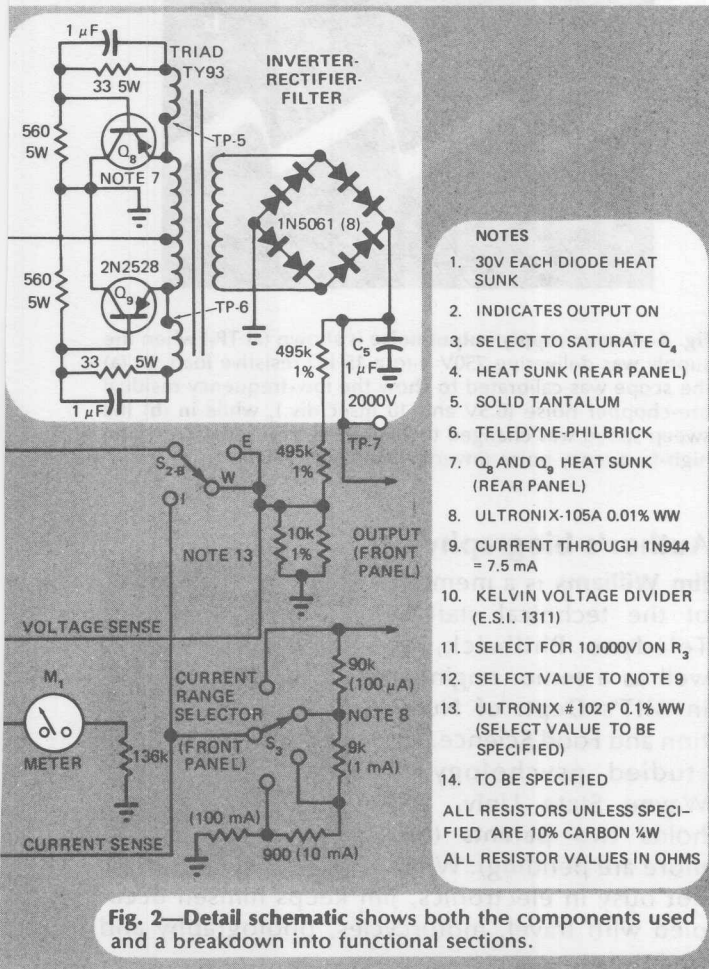

**Fig. 2—Detail schematic** shows both the components used and a breakdown into functional sections.

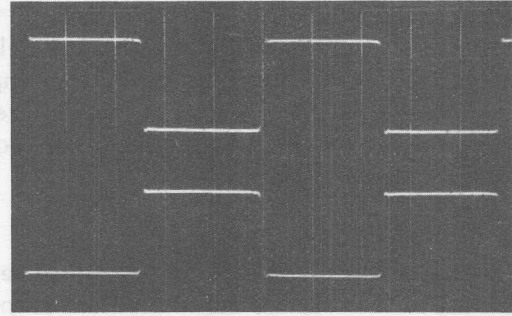

**Fig. 4—Inverter waveforms** taken at TP<sub>5</sub> and TP<sub>6</sub> (the emitters of Q<sub>8</sub> and Q<sub>9</sub>). Scope was set at 50V/div. and 50 μsec/div. Despite the high currents, the combination of suitable transistors and a well-designed transformer obviously yields clean waveforms containing a minimum of ringing or overshoot.

Unity-gain followers, A<sub>2</sub> and A<sub>3</sub>, convert the current and voltage signals to the low impedance needed to drive the 4455 multiplier. The impedance transformation also allows easy monitoring of the respective signals by a voltmeter or a multiplexing data-acquisition system. Switchable meter M<sub>1</sub> provides a “ballpark” indication of the voltage or current at the load. A<sub>1</sub> and A<sub>2</sub> feed the multiplier, which provides the feedback signal for the power mode of operation. Regulation-mode switch S<sub>2</sub> selects which feedback signal (E, W or I) is sent to servo amplifier A<sub>1</sub>, thereby determining the regulation mode of the instrument. R<sub>2</sub>, a 22 MΩ resistor, prevents the servo loop from running wild during the transient condition that exists when the mode switch is operated.

As might be suspected, the servo loop is very prone to oscillation. C<sub>3</sub> and C<sub>4</sub> were included to insure loop stability, but slow it down as well. Loop response is about 75 msec (no load to full load), so transient response clearly is not this circuit's forte.

### Pre-chopper keeps a constant drop

The pre-chopper is essentially a servo that keeps the drop across pass transistor Q<sub>7</sub> at a constant, low voltage, regardless of inverter demand conditions. This lowers dissipation and insures reliability. A<sub>4</sub> looks differentially across the Q<sub>7</sub> pass element. A<sub>4</sub>'s negative input is biased through the 10V zener, D<sub>5</sub>, and its output voltage is compared to a 120-Hz line-synchronized ramp by amplifier, A<sub>5</sub>. This op amp functions as a pulse-width modulator, and drives the Q<sub>3</sub>, Q<sub>4</sub> combination that delivers phase-controlled power to C<sub>2</sub> and the collector of Q<sub>7</sub>. Diode D<sub>4</sub> insures that Q<sub>4</sub> will not be reverse biased when

the 120-Hz signal is below the dc across the capacitor.

Since  $A_4$ 's negative input is routed through the 10V zener,  $Q_7$ 's emitter will always be 10V below the collector, despite the required inverter input power. This value, 10V, is low enough to keep dissipation down, yet high enough to insure good regulation characteristics.

### Loop inside a loop

The battle-scarred veterans among those reading this article will realize the unpleasant surprises that can be encountered by running a servo loop within a servo loop. Here, these embarrassments have been avoided by giving the pre-chopper slower response time than the main servo loop.  $C_1$ , the 2.2- $\mu$ F capacitor across  $A_4$ , satisfies this condition.

The 120-Hz reference ramp arrives at  $A_5$  via the 2N2646 unijunction transistor  $Q_2$ .  $Q_2$ , in turn, is driven by  $Q_1$ , the 2N2907 current source.  $SCR_1$ ,  $D_1$  and  $R_1$ —which is connected to -15V—assure a true zero-volt reset for the ramp.  $D_2$  and  $D_3$  provide the synchronizing signal, which cannot be taken from the bridge rectifier because the bridge output waveform is heavily influenced by the phase angle at which  $Q_8$  and  $Q_9$  fire.

### Carry a crowbar for protection

A 1339 amplifier ( $A_6$ ) helps protect the supply from excessive output current. The amplifier looks at the current-feedback signal and will swing its output to positive saturation if that signal exceeds 10V. In turn,  $SCR_2$  is triggered and grounds the inverter drive signal, resulting in a supply shut-down. The "overload indicate" light ( $I_1$ ) will come on to alert the operator to the situation. To reset, the "overload reset" button is pressed, commutating the SCR and enabling the inverter to again receive bias.  $D_6$ , a 1N914 in the base line of  $Q_6$ , assures a clean turn-off when the SCR comes on.

Overvoltage protection is provided by  $D_{10}$ ,  $D_9$  and  $D_8$ , the 10V zener diode and the 1N914's, which are connected between the "voltage" output signal and  $SCR_2$ . This arrangement prevents the supply from running away in the event of a load dropout when in the "current" or "power" regulation modes.

### Preventing catastrophes

Physical layout of the supply is not critical except for the point grounding considerations common to any precision circuit. The inverter ground return (from  $Q_8$  and  $Q_9$  collectors) contains fast, high-current spikes and should be returned directly to supply common. Returns from the reference diode, its potentiometer and

the amplifiers are also critical. They also should be connected directly to the supply ground.

Particularly insidious failures can result from a malfunction in the pre-chopper circuitry. As an example, assume an emitter-to-collector short in  $Q_4$ . All of the 120-Hz waveform will then be supplied to the 3500- $\mu$ F integrating capacitor, and the dc potential at  $Q_7$ 's collector will rise to maximum voltage. The power supply will, however, continue to function in an apparently normal fashion—that is, until  $Q_7$  achieves its molten state. This most unwelcome state of affairs is prevented by the 175°F thermal switch ( $S_5$ ) mounted next to  $Q_7$ . Closing of the switch will blow the fuse at the transformer primary. □

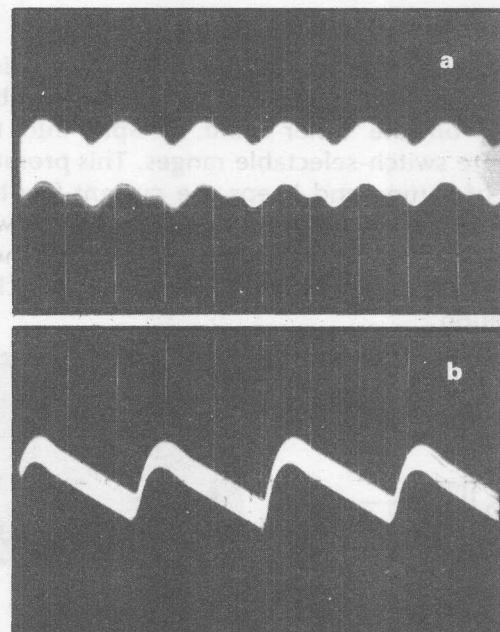

**Fig. 5—Power-supply output noise** is shown (at  $TP_2$ ) when the supply was delivering 750V into a 15 k $\Omega$  resistive load. In (a) the scope was calibrated to show the low-frequency residual pre-chopper noise (0.5V and 10 msec/div.), while in (b) the sweep speed was changed to 20  $\mu$ sec/div. to clearly show the high-frequency noise (inverter frequency related).

### Author's biography

**Jim Williams** is a member of the technical staff at Teledyne Philbrick, as well as a senior engineer in MIT's Dept. of Nutrition and Food Science. He studied psychology at Wayne State Univ. and holds two patents (two more are pending). When not busy in electronics, Jim keeps himself occupied with travel, motorcycles, photography and sculpture.

