

Performance Enhancement Techniques for Three-Terminal Regulators

Jim Williams

Three terminal regulators provide a simple, effective solution to voltage regulation requirements. In many situations the regulator can be used with no special considerations. Some applications, however, require special techniques to enhance the performance of the device.

Probably the most common modification involves extending the output current of regulators. Conceptually, the simplest way to do this is by paralleling devices. In practice, the voltage output tolerance of the regulators can cause problems. Figure 1 shows a way to use two regulators to achieve an output current equal to their sum. This circuit capitalizes on the 1% output tolerance of the specified regulators to achieve a simple paralleled configuration. Both regulators sense from the same divider string and the small value resistors provide ballast to account for the slightly differing output voltages. This added impedance degrades total circuit regulation to about 1%.

Figure 2 shows another way to extend current capability in a regulator. Although this circuit is more complex than Figure 1, it eliminates the ballasting resistor's effects and has a fast-acting logic-controlled shutdown feature. Additionally, the current limit may be set to any desired value. This circuit extends the 1A capacity of the LT1005 multi-function regulator to 12A, while retaining the LT1005's enable feature and auxiliary 5V output. Q1, a booster transistor, is servo-controlled by the LT1005, while Q2 senses the current dependent voltage across the 0.05Ω shunt. When the shunt voltage is large enough, Q2 comes on, biasing Q3 and shutting down the regulator via the LT1005's enable pin. The shunt's value can be selected for the desired current limit. The 100°C thermoswitch limits dissipation in Q1 during prolonged short circuits by disabling the LT1005. It should be mounted on Q1's heat sink.

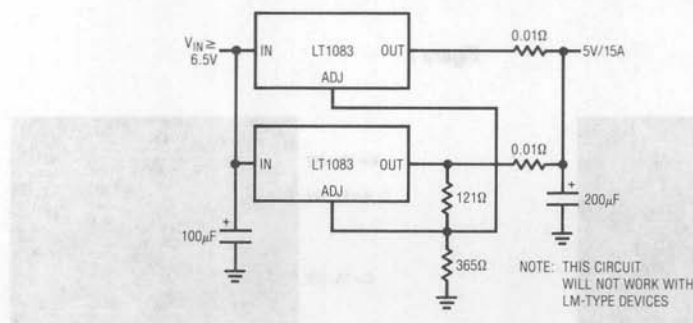

Figure 1

Application Note 2

Boosted regulator schemes of this type are often poorly dynamically damped. Such improper loop compensation results in large output transients for shifts in the load. In particular, because Q1's common emitter configuration has voltage gain, transients approaching the input voltage are possible when the load drops out. Here, the $100\mu\text{F}$ capacitor damps Q1's tendency to overshoot, while the 20Ω value provides turn-off bias. The $250\mu\text{F}$ unit maintains Q1's emitter at DC. Figure 3 shows that this "brute force" compensation works quite well. Normally the regulator sees no load. When Trace A goes high, a 12A load (regulator output current is Trace C) is placed across the output terminals. The regulator output voltage recovers quickly, with minimal aberration.

While the $100\mu\text{F}$ output capacitor aids stability, it prevents the regulator output from dropping quickly when the enable command is given. Because Q1 cannot sink current, the $100\mu\text{F}$ unit's discharge time is load limited. Q4 corrects this problem, even when there is no load. When the enable command is given (Trace A, Figure 4) Q3 comes on, cutting off the LT1005 and forcing Q1 off. Simultaneously, Q4 comes on, pulling down the regulator output (Trace B), and sinks the $100\mu\text{F}$ capacitor's discharge current (Trace C). If fast turn-off is not needed, Q4 may be omitted.

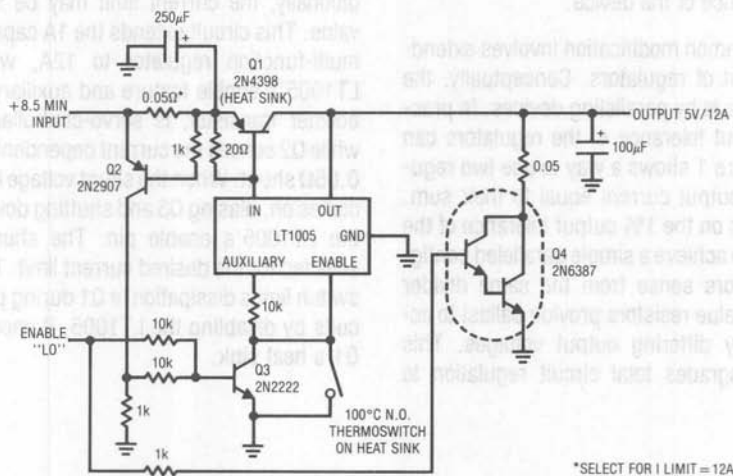

Figure 2

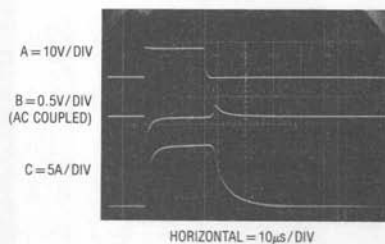

Figure 3

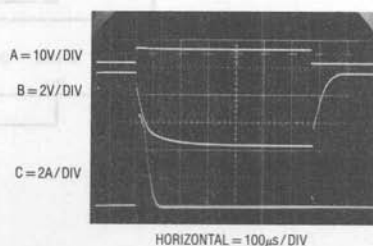

Figure 4

Power dissipation control is another area where regulators can be helped by additional circuitry. Increasing heat sink area can be used to offset dissipation problems, but is a wasteful and inefficient approach. Instead, the regulator can be placed within a switched-mode loop that servo-controls the voltage *across* the regulator. In this arrangement the regulator functions normally while the switched-mode control loop maintains the voltage across it at a minimal value, regardless of line or load changes. Although this approach is not quite as efficient as a classical switching regulator, it offers lower noise and the fast transient response of the linear regulator. Figure 5 details a DC driven version of the

circuit. The LT350A functions in the conventional fashion, supplying a regulated output at 3A capacity. The remaining components form the switched-mode dissipation limiting control. This loop forces the potential across the LT350A to equal the 3.7V value of V_Z . When the input of the regulator (Trace A, Figure 6) decays far enough, the LT1018 output (Trace B) switches low, turning on Q1 (Q1 collector is Trace D). This allows current flow (Trace C) from the circuit input into the 4500 μ F capacitor, raising the regulator's input voltage. When the regulator input rises far enough, the comparator goes high, Q1 cuts off and the capacitor ceases charging.

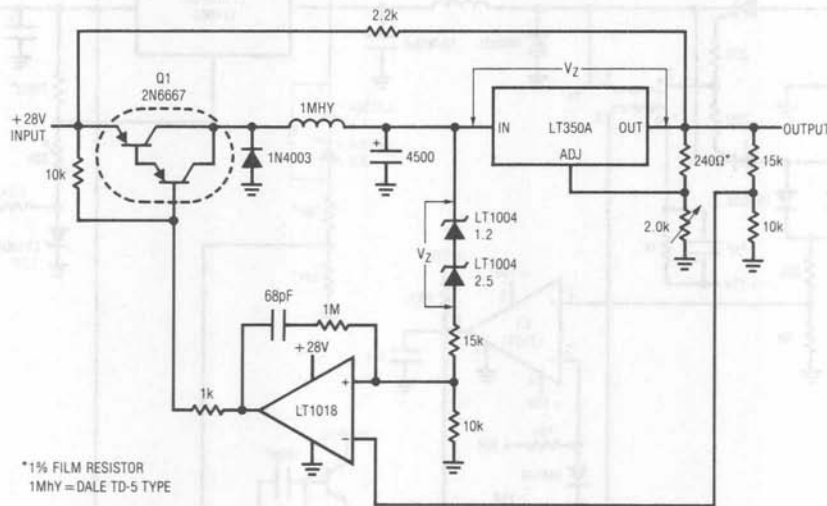

Figure 5

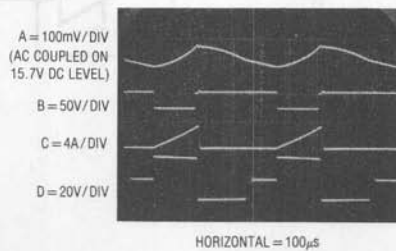

Figure 6

Application Note 2

The 1N4003 damps the flyback spike of the current limiting inductor. The 4.7k Ω unit ensures circuit start-up and the 68pF-1M Ω combination sets loop hysteresis at about 80mVp-p. This free-running oscillation control mode substantially reduces dissipation in the regulator, while preserving its performance. Despite changes in the input voltage, different regulated outputs or load shifts, the loop always ensures the minimum possible dissipation in the regulator.

Figure 7 shows the dissipation limiting technique applied in a more sophisticated circuit. This AC powered version provides 0V-35V, 10A regulation under high line-low line (90VAC-140VAC) conditions with good efficiency. In this version, two SCRs and a center tapped transformer source power to the inductor-capacitor combination. The transformer output is also diode rectified (Trace A, Figure 8), divided down, and used to reset the 0.1 μ F unit (Trace B)

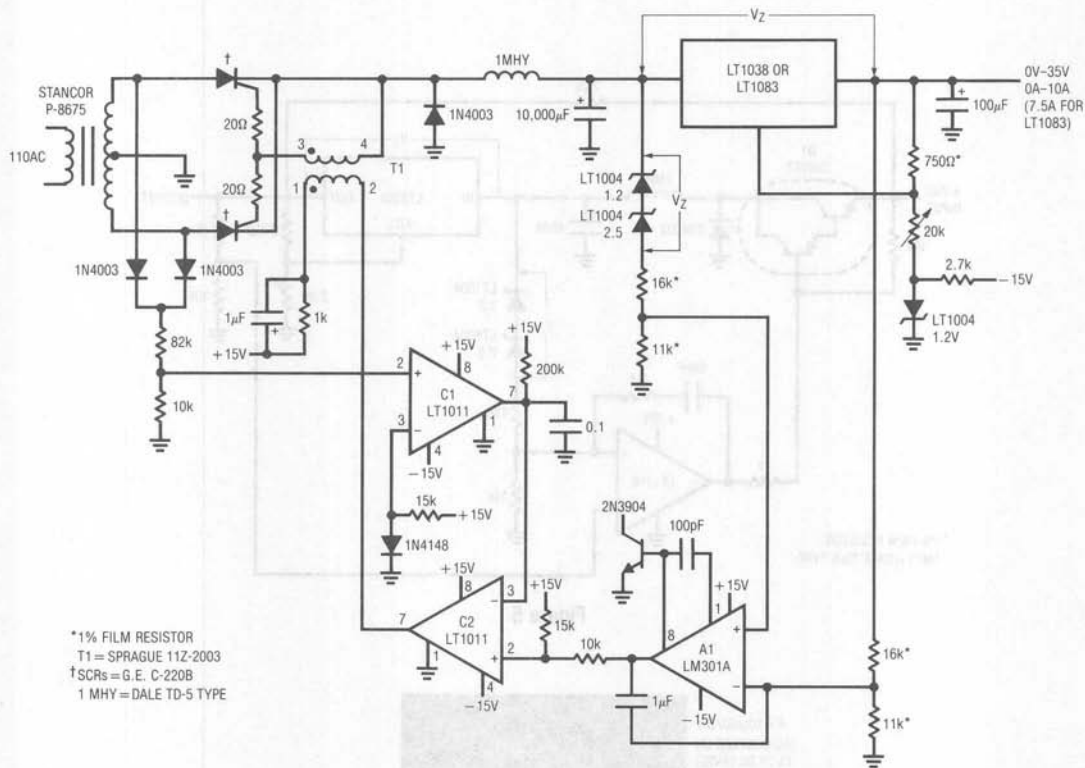

Figure 7

via C1. The resulting AC line synchronous ramp at C1's output is compared to A1's offset output by C2. A1's output represents the deviation from the V_Z value that the loop is trying to force across the LT1038. When the ramp output exceeds C2's "+" input value, C2 pulls low, dumping current through T1's primary (Trace C). This fires the appropriate SCR and a path from the main transformer to the LC pair occurs (Trace D). The resultant current flow (Trace E) is limited by the inductor and charges the capacitor. When the AC line cycle drops low enough, the SCR commutates and charging ceases. On the next half-cycle the process repeats, except that the alternate SCR does the work. In this fashion, the loop controls the phase angle at which the SCRs fire to keep the voltage across the

LT1038 at V_Z (3.7V). As a result, the circuit functions over all line, load and output voltage conditions with good efficiency. The 1.2V LT1004 at the LT1038 allows the output voltage to be set down to 0.00 and the 2N3904 clamp at A1 prevents loop "hangup". Figure 7A shows a way to trigger the SCRs without using a transformer.

Although A1's output is an analog voltage, the AC driven nature of the circuit makes it approximate a smoothed, sampled loop response. Conversely, the regulator constitutes a true linear system. Because these two feedback systems are interlocked, frequency compensation can be difficult.

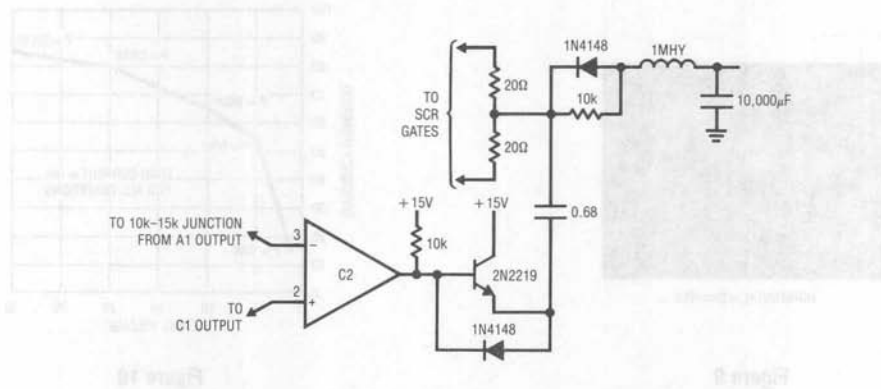

Figure 7A

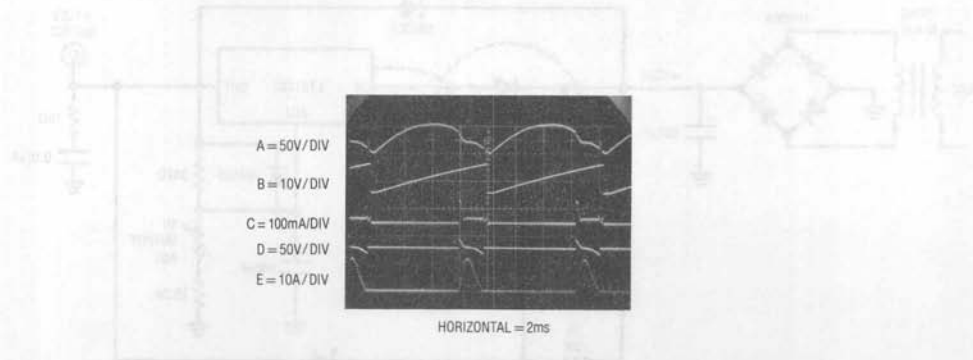

Figure 8

Application Note 2

In practice, A1's $1\mu\text{F}$ capacitor keeps dissipation loop gain at a low enough frequency for stable characteristics, without influencing the LT1038's transient response characteristic. Trace A, Figure 9 shows the output noise while the circuit is operating at 35V into a 10A load (350W). Note the absence of fast switching transients and harmonics. The output noise is made up of residual 120Hz ripple and regulator noise. Reflected noise into the AC power line is also negligible (Trace B) because the inductor limits current rise time to about 1ms, much slower than the normal switching supplies. Figure 10 shows a plot of efficiency versus output voltage for a 10A load. At low output voltages, where the static losses across the regulator and SCRs are significant, efficiency suffers, but 85% is attained at the upper extreme.

High voltage output is another area for regulator enhancement. In theory, because the regulator does not have a ground pin, it can regulate high voltages. In normal operation the regulator floats at the supply's upper level, and as long as the $V_{IN}-V_{OUT}$ maximum differential is not exceeded there are no problems. However, if the output is shorted, the $V_{IN}-V_{OUT}$ maximum is exceeded and device destruction will occur. The circuit of Figure 11 shows a complete high voltage regulator that delivers 100V at 100mA and withstands shorts to ground. Even at 100V output the LT317A functions in the normal mode, maintaining 1.2V between its output and adjustment pin.

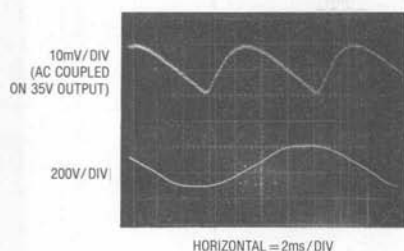

Figure 9

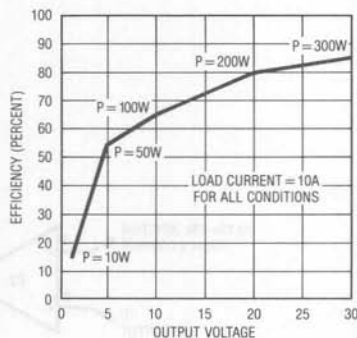

Figure 10

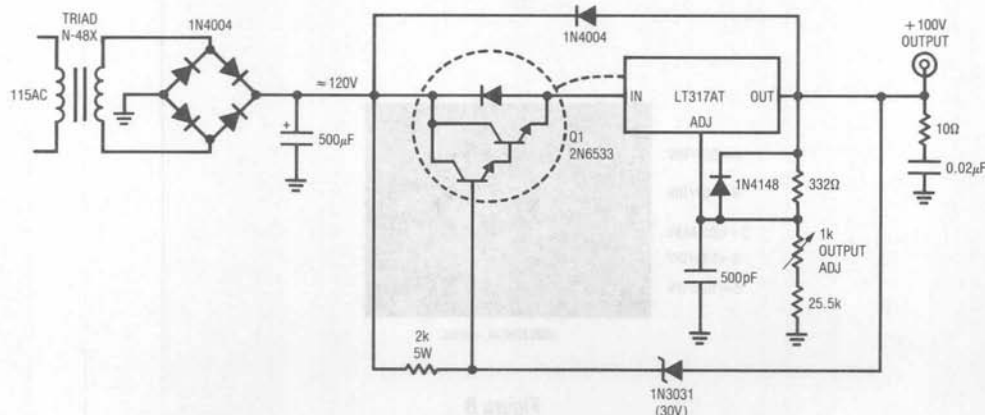

Figure 11

Under these conditions the 30V zener is off and Q1 conducts. When an output short occurs, the zener conducts, forcing Q1's base to 30V. This causes Q1's emitter to clamp $2 V_{BE}$ below V_Z , well within the $V_{IN}-V_{OUT}$ rating of the regulator. Under these conditions, Q1, a high voltage device, sustains 90V V_{CE} at whatever current the transformer and the regulator's current limit will support. The transformer specified saturates at 130mA, keeping Q1 well within its safe area as it dissipates 12W. If Q1 and the LT317A are thermally coupled, the regulator will soon go into thermal shutdown and oscillation will commence. This action will continue, protecting the load and the regulator as long as the output remains shorted. The 500pF capacitor and the 10Ω-0.02μF damper aid transient response and the diodes provide safe discharge paths for the capacitors.

This approach to high voltage regulation is primarily limited by the power dissipation capability of the device in series with the regulator. Figure 11A uses a vacuum tube (remember them?) to achieve very high short circuit dissipation capability. The tube allows high voltage operation and is extremely tolerant of overloads. This circuit allows the LT317A to control 600W at 2000V (V_1 's plate limit is 300mA) with full short circuit protection.

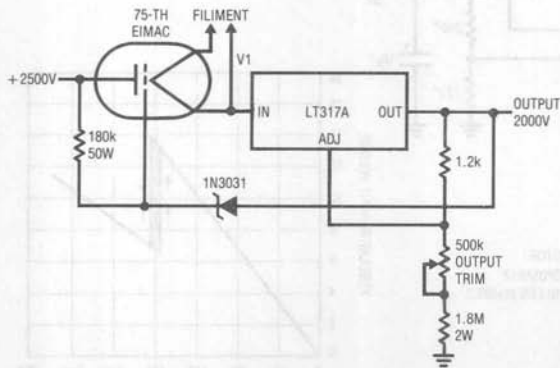
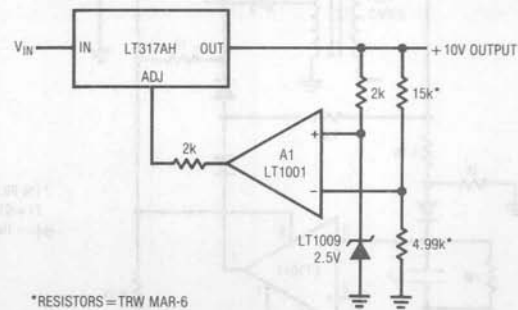

Figure 11A

Power is not the only area in which regulator performance can be augmented. Figure 12 shows a way to increase the stability of a regulator's output over time and temperature. This is particularly useful in powering strain gauge-based transducers. In this circuit the output voltage is divided down and compared to the 2.5V reference by A1, a precision amplifier. A1's output is used to force the LT317A's adjustment pin to whatever voltage is required to maintain the 10V output. A1 contributes negligible error. The resistors specified will track within 5ppm/°C and the reference contributes about 20ppm/°C. The regulator's internal circuitry protects against short circuits and thermal overload.

Figure 13's circuit allows a regulator to remotely sense the feedback voltage, eliminating the effects of voltage drop in the supply lines. This is a concern where high currents must be transmitted over relatively long supply rails or PC traces. Figure 13's circuit uses A1 to sense the voltage at the point of load. A1's output, summed with the regulator's output, modifies the adjustment pin voltage to compensate for the voltage lost across R_{DROP} . The feedback divider is returned through a separate lead from the load, completing the remote sensing scheme. The 5μF capacitor filters noise and the 1k value limits bypass capacitor discharge when power is turned off.



*RESISTORS = TRW MAR-6

Figure 12

Application Note 2

A final circuit allows voltage regulator-powered circuitry to run from 110VAC or 220VAC without having to switch transformer windings. Regulator dissipation does not increase for 220VAC inputs. In Figure 14, when T1 is driven from 110VAC, the LT1011 output goes high, allowing the SCR to receive gate bias through the 1.2k resistor. The 1N4002 is off. T1's output is rectified by the SCR and the regulator sees about 8.5V at its input. If T1 is plugged into a 220VAC source, the negative input at the LT1011 is driven beyond 2.5V and the device's output clamps low. This steers the SCR's gate bias to ground through the LT1011's output transistor. The diodes in the

LT1011 output line prevent reverse voltages from reaching the SCR or the LT1011 output. Now, the SCR goes off and the 1N4002 sources current to the regulator from T1's center tap. Although T1's input voltage has doubled, its output potential has halved and regulator power dissipation remains the same. Figure 15 shows the AC line input versus regulator input voltage transfer function. The switch to center tap drive occurs midway between 110VAC and 220VAC. The hysteresis, a desirable characteristic, occurs because T1's output voltage shifts with the step change in loading.

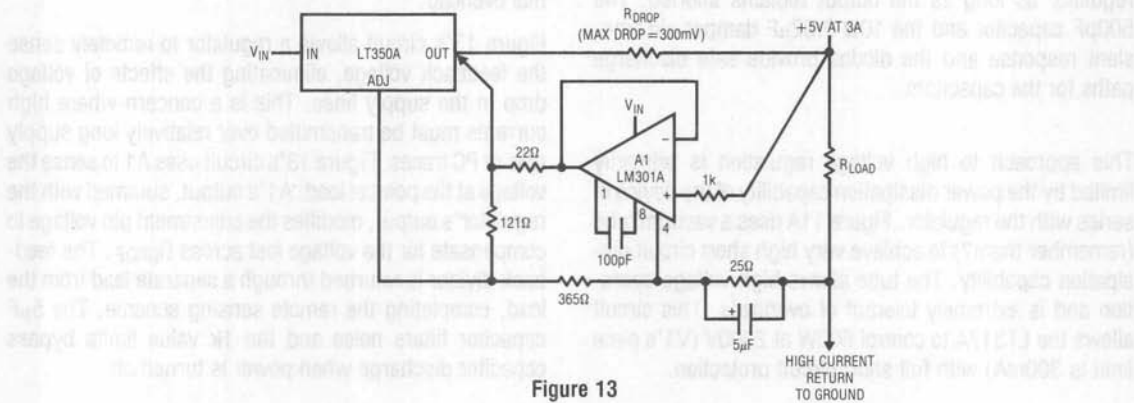

Figure 13

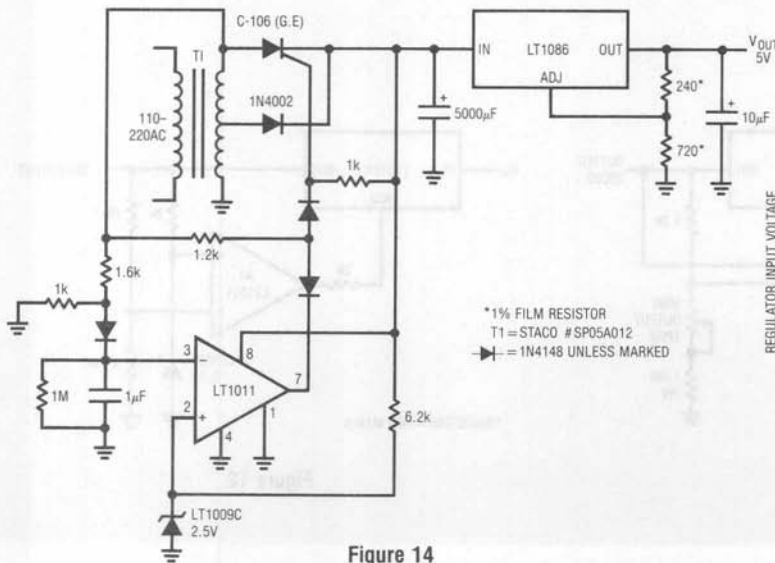

Figure 14

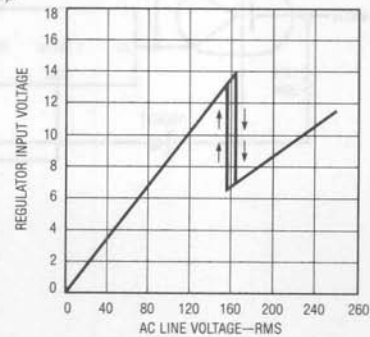

Figure 15