

## VERY LOW DROP REGULATORS ENHANCE SUPPLY PERFORMANCE

By Paolo ANTONIAZZI and Arturo WOLFSGRUBER

Standard three-terminal voltage regulator ICs use an NPN transistor as the series pass element, so the input-output voltage drop is 1.5V-2V. Low dropout regulators using lateral PNP pass transistors have been available for several years, but a lateral PNP transistor has low gain, so the base current is necessarily high, and a low  $f_r$ , so the settling time is poor. Moreover, for stability a large output capacitor is needed.

Applying a new bipolar technology (see APPENDIX : Technology Is The Key) SGS-THOMSON has

developed two 5V low drop voltage regulators that use a new vertical PNP transistor structure to obtain low dropout and low quiescent current.

Type L4940 delivers up to 1.5A and offers an input-output voltage drop of 700mV at the full 1.5A output current. A 1A version, type L4941, has an input-output drop of 450mV at 1A (100mV at 0.1A). Both types have a quiescent current of 15mA at 1A (4mA with no load). Consequently these devices dissipate less power, improving the efficiency of any supply system (figure 1).

**Figure 1 :** A voltage regulator using vertical isolated PNP transistor is more efficient than regulators with NPN pass transistors because the drop out is lower. And it is more efficient than a regulator having a lateral PNP pass transistor because the quiescent current is lower.

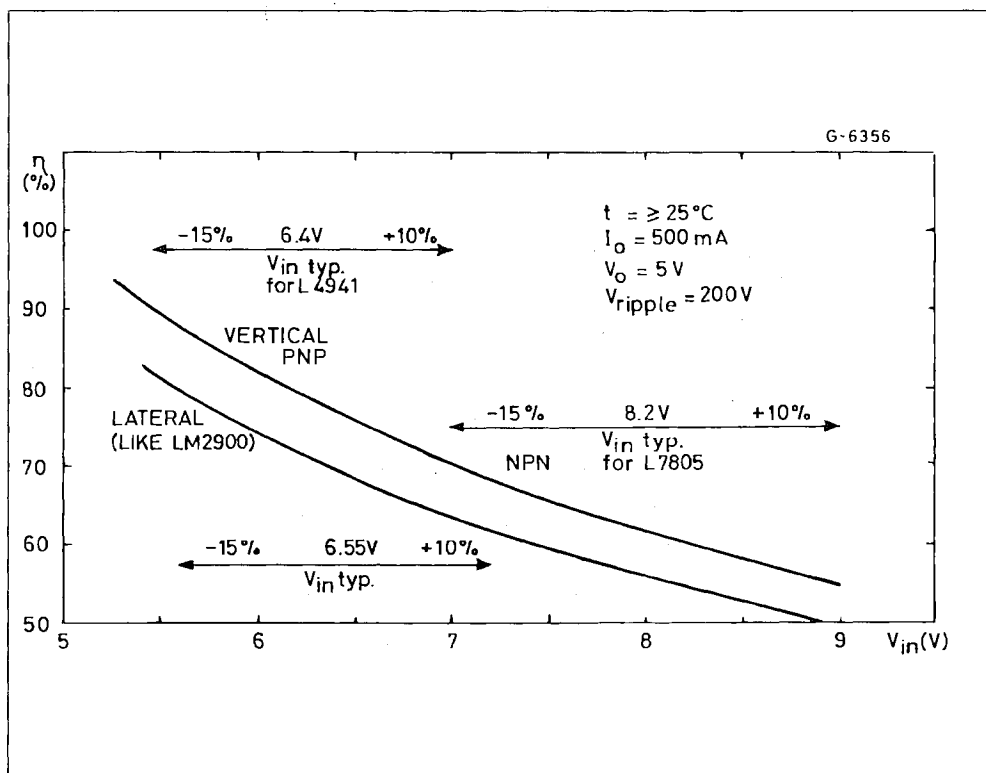

Compared to other "low drop" regulator the L4940 and L4941 have other advantages : regulation performance is guaranteed right down to the minimum input voltage and the device is stable even without an output capacitor. Additionally, a special circuit limits the quiescent current for input voltages from 3V to 5V, typically high for low drop regulators because of the saturation of the series regulator.

The two application areas which benefit the most from second generation low drop regulators like the L4940 and L4941 are post regulation and battery supplies. However, the device brings cost savings in any three-terminal regulator application.

**LOW DISSIPATION REDUCES SIZE, WEIGHT & COST**

In simple series regulator applications the low dissipation of the L4940/1 reduces the size and weight of the mains transformer, heatsink and printed circuit board. A comparison between equivalent 5V/1A circuits using the L4941 and a standard L7805 regulator (figure 2) shows that the L4941 solution is not only more compact and lighter, it also costs less since the difference in costs between an L4941 and an L7805 is less than the cost saving.

**Figure 2 :** In simple series regulator applications the L4941 can replace standard three-terminal regulators like the L7805, reducing size, weight and cost. Heat dissipation is reduced, too.

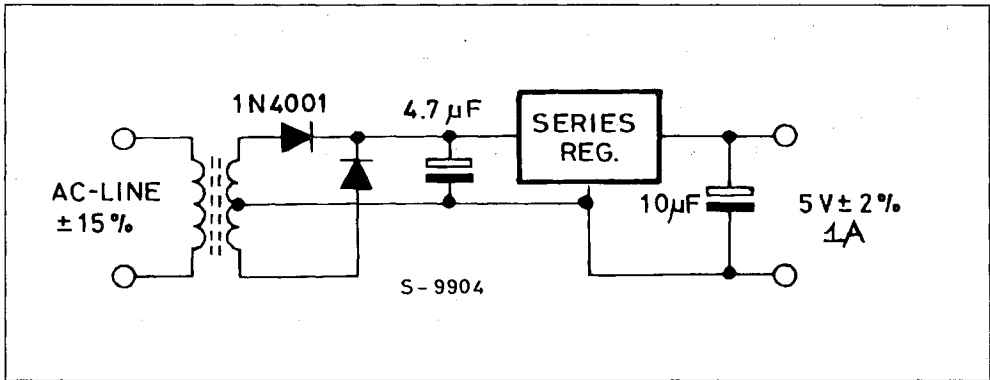

**COMPARISON BETWEEN L7805 AND L4941**

Component	L4941		L7805	
	Value	Cost*	Value	Cost*
Transformer	220V/7.5V 9.4VA	\$4.8	220V/8.6V 11VA	\$5.4
Diodes	2x1N4001	\$0.1	2x1N4001	\$0.1
Capacitors	4.7µF 10V	\$0.5	4.7µF 16V	\$0.75
	10µF	\$0.1	100n	\$0.08
Heatsink	20°C/W	\$0.2	10°C/W	\$0.3
PC Area	20cm <sup>2</sup>	\$0.27	26cm <sup>2</sup>	\$0.35
		<b>\$5.97</b>		<b>\$6.98</b>

The L4941 solution, excluding the cost of the IC, is thus \$1 cheaper. Moreover it is lighter, more compact and dissipates 1.6W less.

\* guide price for 1000 pieces.

These low drop regulators also bring important benefits in supplies using post regulation, the technique where one or more linear regulators follow another regulator (often switching), to improve precision, reduce ripple and improve transient response. Though lightweight and cheap, an offline switching regulator suffers from poor load and line regulation and needs additional chokes and capacitors to reduce ripple.

Using standard regulators the efficiency of post regulation systems is low because the intermediate voltage must be high enough to allow for the post regulator's voltage drop. Moreover, a lateral PNP

low drop regulator has a poor transient response so it cannot reject switching ripple effectively.

If L4940s or L4941s are used for post regulation the intermediate voltage need only be 1V above the final output voltage and 40dB SVR can be obtained at 30kHz. Consequently less power is dissipated both in the post regulators and in the pre-regulator, making post regulation much more attractive -- designers can now have the precision, low ripple and fast response without sacrificing efficiency.

Figure 3 shows a typical post-regulation power supply using a switching regulator, based on the L4960, followed by L4941 low drop regulators.

**Figure 3 :** Low drop regulators like the L4941 improve the efficiency of post regulation supplies because less power is dissipated and because the intermediate voltage can be lower. In this typical supply design an L4960 offline switching regulator is followed by L4941 post regulators, giving an high overall efficiency.

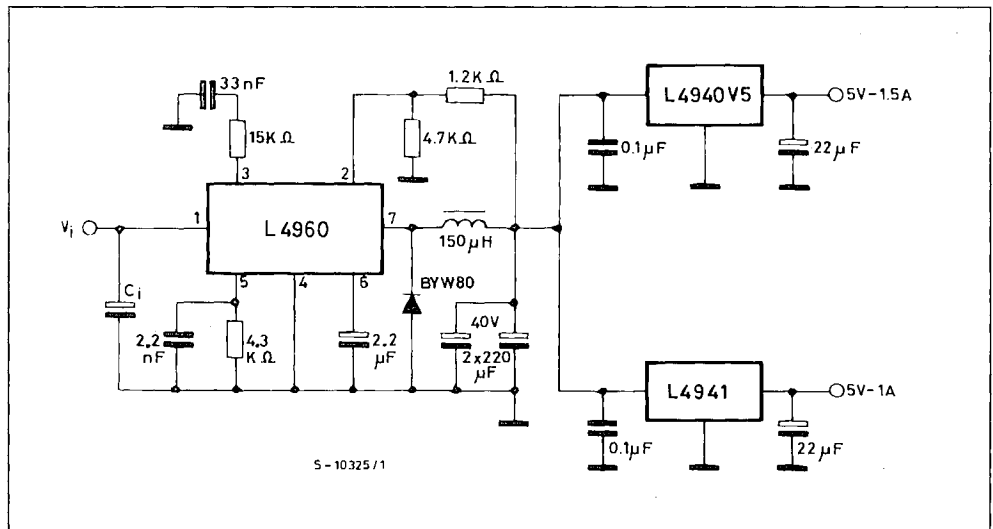

**IMPROVING BATTERY SUPPLIES**

The second application area where the L4940 and L4941 are particularly useful is in battery-powered equipment. Because of their lower dropout these devices need fewer battery cells -- five, compared to the six needed for an NPN regulator. In addition, with five NiCd cells the efficiency is 77-96% and the cells can be completely discharged.

The low quiescent current of the L4940 and L4941 reduces power consumption, prolonging battery life. Moreover, since they will continue to provide a stable 5V output with input voltages as low as 5.45V they also extend the effective battery life by allowing continued operation when the battery would previously have been discarded (figure 4).

**Figure 4 :** The vertical PNP pass transistor permits a minimum dropout without the penalty of higher quiescent current, giving a 30-50% longer battery life in equipment drawing a constant current two hours a day.

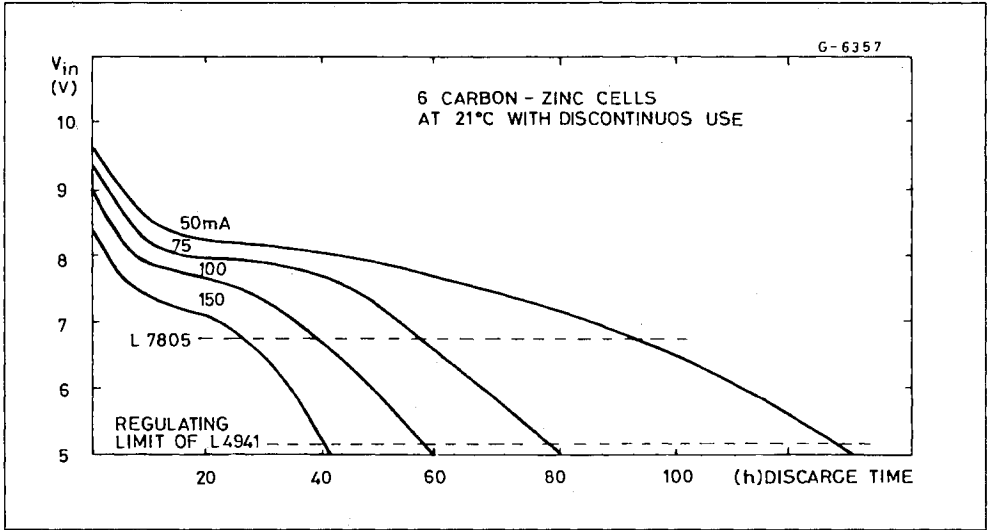
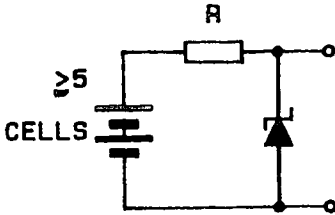
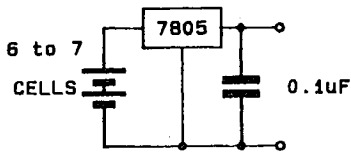

Figure 5 shows how an L4941 solution compares with five alternative 5V battery supplies.

**Figure 5 :** The L4941 is also useful in battery-powered equipment, prolonging battery life by reducing current drain and supplying a regulated 5V output until the battery voltage has fallen to 5.45V. Here the L4941 solution is compared with five alternatives.



1. ZENER REGULATOR -- High current consumption when battery fully charged and high losses in  $R_{ser}$ .



2. NPN SERIES REGULATOR -- Needs at least 7Znn/C, 6NiCd or 4Pd cells..

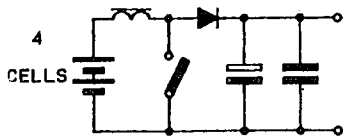

3. DC-DC CONVERTERS -- Complicated and costly. Generates EMI and average efficiency  $\leftarrow 75\%$ .

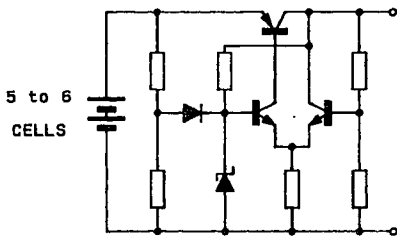

4. DISCRETE LOW DROP REGULATOR -- Bulky and performs poorly in comparison with integrated solutions.

Figure 5 (continued).

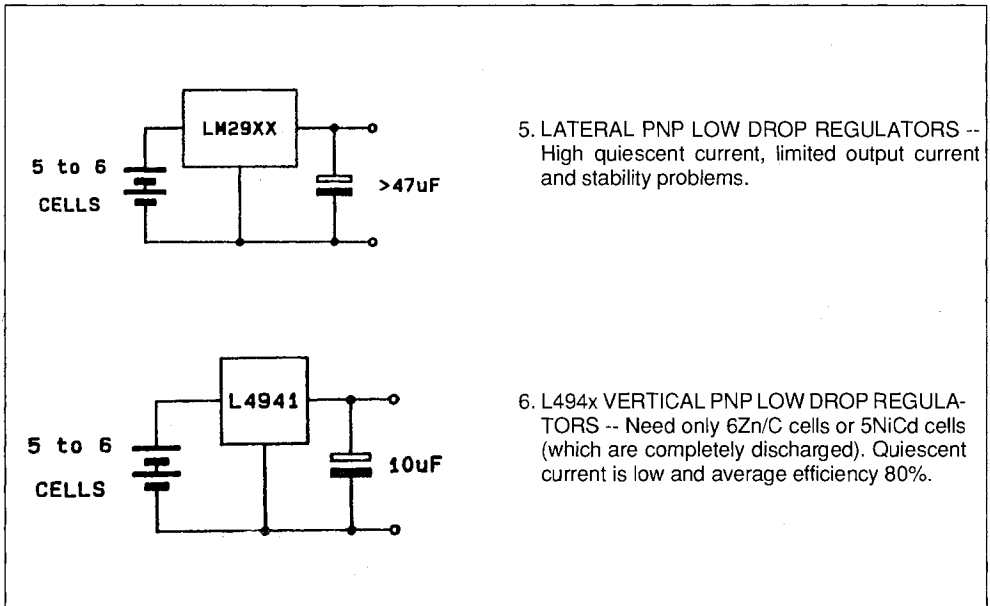

HIGHER CURRENT

To obtain more than 1.5A output current a discrete PNP transistor can be added to the L4940 as shown in figure 6. In this circuit Q2 is a current limiter to pro-

tect the external pass transistor when the output is short circuited. An on-chip protection circuit prevents damage to the L4940.

When the load current does not vary greatly higher

Figure 6 : An external PNP transistor can be added to the L4941 to obtain higher output current. Q2 is a current limiter to protect the external transistor.

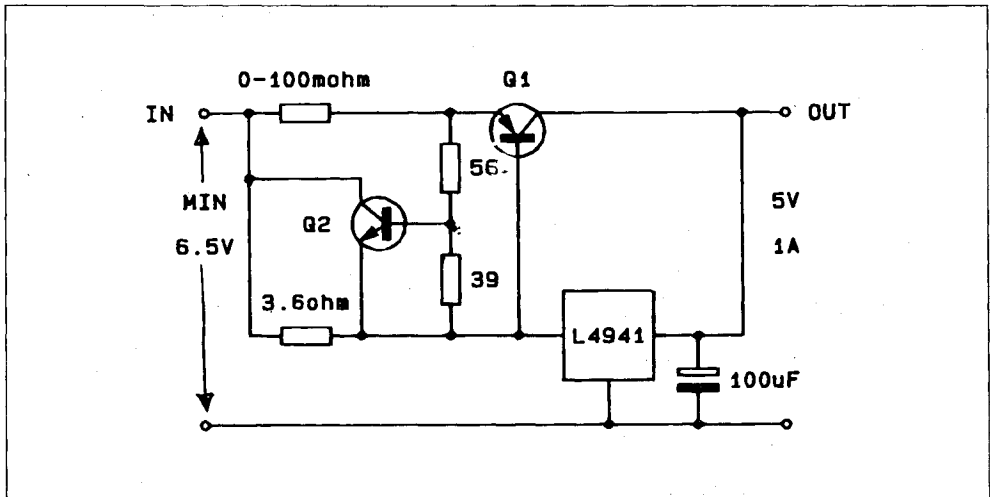

output current can also be obtained by using a shunt resistor as shown in figure 7.

**Figure 7 :** If the load current does not vary much a simple way to obtain higher current is to add a shunt resistor.

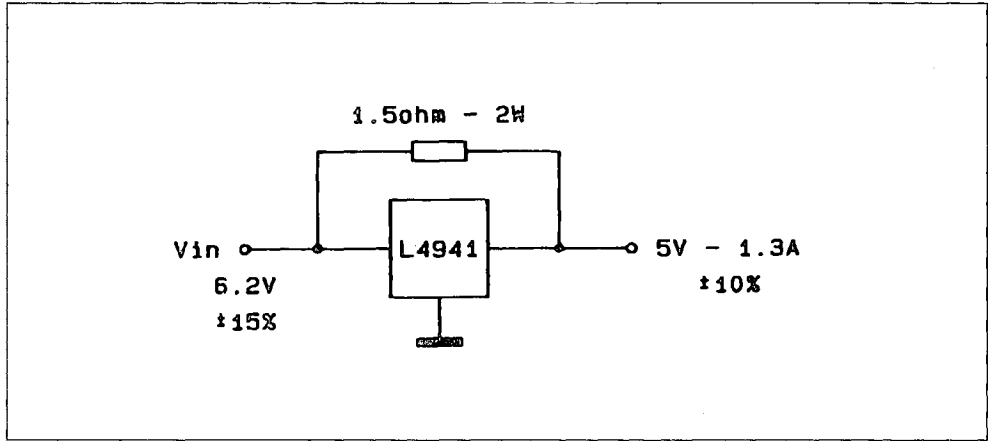

Another way to obtain higher current is simply to connect several devices in parallel as shown in figure 8. This solution also increases the overall re-

liability of the system and is useful also when reliability is of prime importance.

**Figure 8 :** Multiple L4941s can be paralleled to increase both output current and reliability.

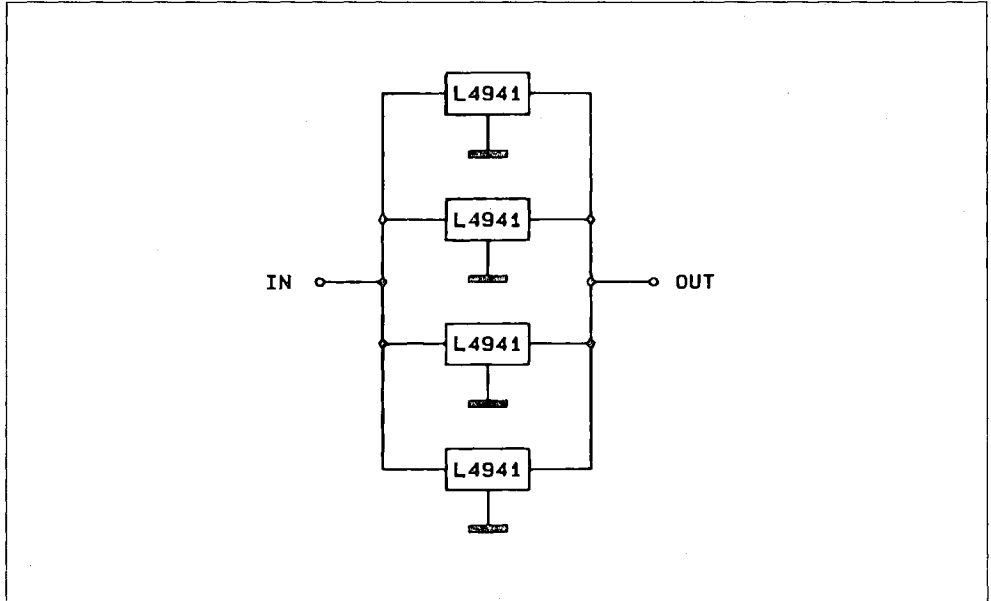





## APPENDIX : TECHNOLOGY IS THE KEY

In parallel with the emergence of mixed bipolar/DMOS processes, pure bipolar technology has made significant advances, too. One of the most important of these advances ? the development of a new power PNP transistor structure -- the isolated collector vertical PNP (ICV PNP) -- which is similar in performance to NPN power transistors.

The ICV PNP is a key element in the SGS-THOMSON MICROELECTRONICS Multipower-HDS<sup>2</sup> P<sup>2</sup>

(HDS<sup>2</sup> P<sup>2</sup> = High Density Super Signal/Power Process) used to design the L4940 & L4941 low drop regulators, a 20V "Multipower" process which offers NPN & ICV PNP power transistors, small signal NPN & PNP transistors, IIL logic, ECL logic and a new low leakage diode structure (see fig. 11).

**Figure 11** : Multipower bipolar process with new ICV-PNP (isolated collector vertical PNP), similar in performance to NPN power transistors.

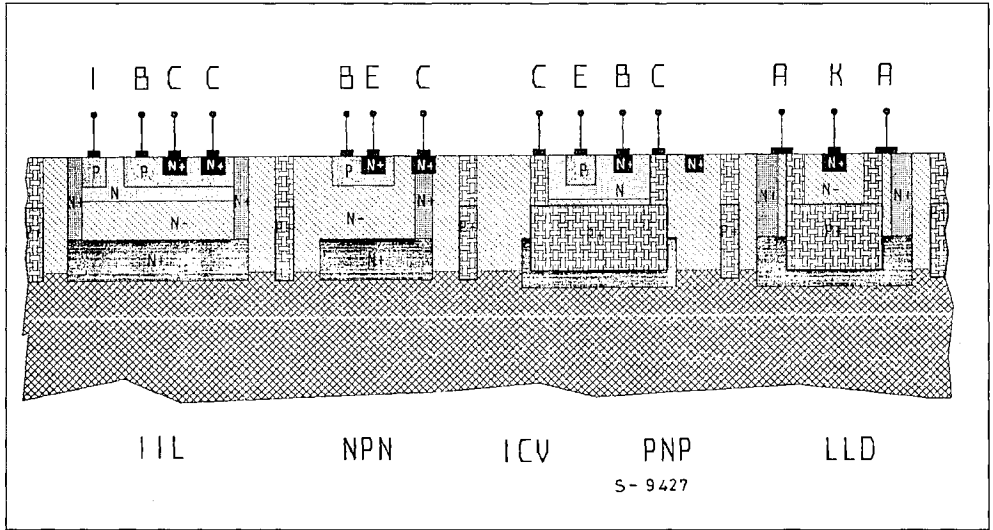

This process is characterized by an exceptionally high current density -- 6A/mm<sup>2</sup> for NPN transistors ; 2A/mm<sup>2</sup> for PNP transistors (at V<sub>SAT</sub> = 1V, H<sub>FE</sub> = 10) -- and very high density in the signal processing section.

Thanks to the ICV PNP power transistor structure, designers can choose any output configuration -- low side, high side, half bridge, bridge. In addition, the low voltage drop of the ICV PNP is very useful in applications where the dropout voltage is critical - in voltage regulators and automotive solenoid drivers, for example.

Another new structure offered by Multipower-HDS<sup>2</sup> P<sup>2</sup>, the Low Leakage Diode (LLD) is very useful in power ICs driving inductive loads. With a parasitic PNP gain about four orders of magnitude lower than

conventional diodes, the LLDs reduce dissipation in the chip -- always an important consideration in power IC design.

Multipower-HDS<sup>2</sup> P<sup>2</sup> can be applied in simple products where an ICV PNP output stage is needed such as the L4941. Moreover, because it allows the integration of very complex control circuits it is also used for power ICs which integrate a complete power subsystem such as the L6217, a single chip microstepping drive for stepper motors.

A similar process rated at 60V -- Multipower-S<sup>2</sup> P<sup>2</sup> -- has also been developed. While Multipower-HDS<sup>2</sup> P<sup>2</sup> is aimed at low voltage, high complexity applications, Multipower-S<sup>2</sup> P<sup>2</sup> is intended for higher voltage applications with medium complexity control circuits.