

## Construction project:

# Powermate II

Need to operate your mobile CB or amateur radio gear in the workshop? Here's an updated version of one of our most popular-ever power supplies. It delivers clean, well-regulated 13.8V DC at up to 5 amps.

by JIM ROWE

Ten years ago, back in May 1978, *EA* described a 13.8V/5A power supply called the "VK Powermate". It was specifically intended to power amateur radio and CB transceivers designed for mobile operation from a nominal 12V battery supply, but could obviously be used for any other similar equipment.

The design was a good one, combining excellent performance with low price, and many VK Powermate supplies were built. In fact over the years it has proved to be one of our most popular power supply designs – far more popular than those of either higher or lower power rating. Apart from the standard of the design itself, this may well be due to the designed average current level of around 5 amps.

Certainly a lot of mobile gear seems to operate in this range, so that a supply like the Powermate which provides this capability at an economical price has a lot of appeal.

In fact the only cheaper way to operate mobile equipment from the 240V mains would be to use a spare 12V battery, with a low-cost trickle charger used to restore battery charge between operating periods. But this approach is messy, and also involves a power trade-off: the voltage of a battery falls to around the nominal 12V when under load without charging, whereas most equipment designed for mobile use is intended to take advantage of the 13.8V produced by a battery when under charge. In other words, to produce full power output the equipment should be operated from 13.8V.

Because the original VK Powermate design is now 10 years old, many of the parts it used are not as easy to obtain as they were. On the other hand, there are now other parts available, which can be used to make a very simi-

lar unit either more easily or at a lower price. Hence our decision to revamp the design, and come up with the new Powermate II design described here.

The performance of the new version is very close to that of the original. Output voltage regulation for loads from zero up to just on 6A is excellent, dropping only about 10mV. That gives an effective output impedance of about 2 milliohms!

Over the same output current range, output ripple is less than 6mV peak to peak – which shouldn't produce hum even with the most sensitive of equipment. These figures hold up for line voltage variations between 220V and 260V, with the line regulation itself being also better than 10mV.

In effect, for all practical purposes it's the closest you could get to an "electronic 13.8V battery", within the current range concerned and bearing in mind its moderate price.

By the way, according to my calcula-

tor the full set of parts for the Powermate II should cost you about \$95 – assuming you cut the holes in the front panel yourself, and use a plain panel. Not exactly dirt cheap, but I doubt if you could do better for a supply of this rating and performance. Note that this price estimate *includes* the power transformer.

### The circuit

Essentially the circuit is identical with that for the original design. It is based as before on a readily available 18V/6A power transformer, driving a bridge rectifier followed by a linear voltage regulator circuit.

Mains power is switched to transformer T1 via DPDT switch SW1, which is an illuminated toggle type with an internal neon and zener. The 1.5A mains fuse is mainly to provide protection against the unlikely event of T1 developing a short.

Note that the mains earth is taken to the frame of T1, again in the interests of safety.

Unlike the original design, the bridge rectifier uses four low-cost 3A power diodes (1N5404 or similar) rather than an encapsulated bridge. This has been done for economy – four discrete 3A

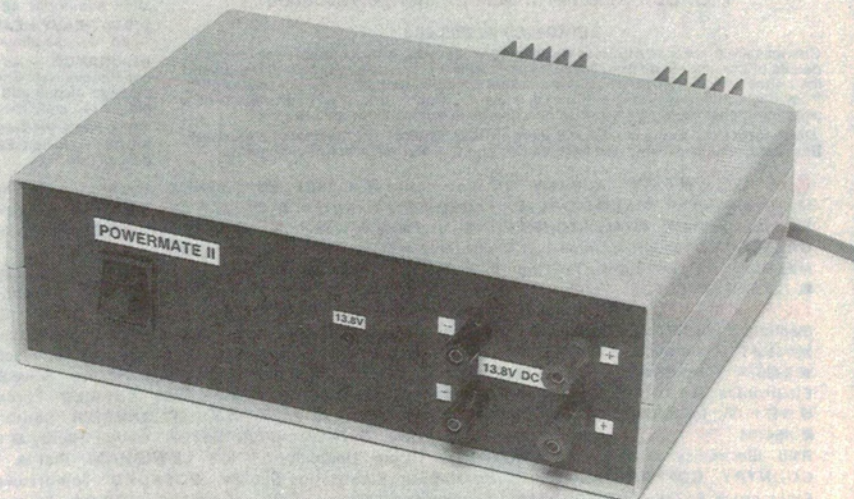

The complete circuit for our new supply, which is very similar to the original. Four separate 3A diodes are used in place of a bridge.

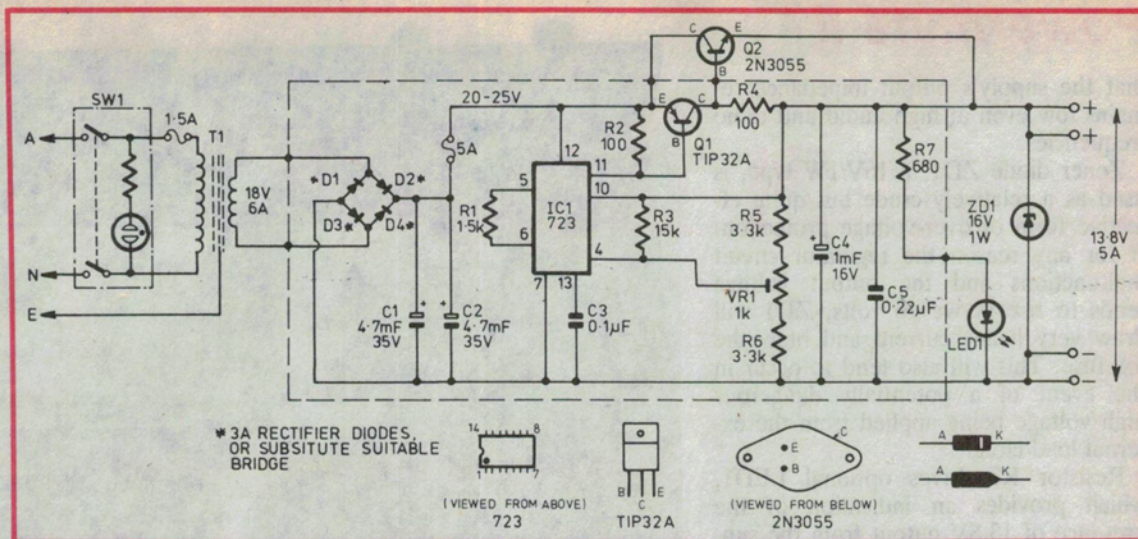

diodes can handle approximately 6A average, but cost around half the price of a typical 6A bridge.

The PCB for the new design has provision for the four discrete diodes to be mounted on it (or strictly, lifted up from it by the length of their leads), without heatsinks. This approach allows them to handle up to 5A continuously, or 6A for short periods with "cool-down" spells between, without getting excessively hot. However if your Powermate II is to operate with a load of 5-6A continuously and you're concerned about the diodes getting too hot, you can replace them with a bridge mounted off the board on a solid heatsink.

The reservoir capacitance for the rectifier is provided by C1 and C2, giving a nominal total of 9.4mF (millifarads). This is slightly lower than for the original design, which used two 5.6mF capacitors for a nominal total of 11.2mF. However this has negligible effect on output regulation or ripple, perhaps because of the low "headroom" required by the regulator circuit. The reason for using 4.7mF capacitors instead of 5.6mF is that they're somewhat cheaper and more readily available.

But note that you should be able to fit 5.6mF capacitors into the board, if you wish to.

A 5-amp fuse is connected between the reservoir capacitors and the regulator circuit, largely to provide protection for the power transformer - the most expensive component in the circuit. This fuse is mounted internally on the PCB, as it should rarely need replacement.

The regulator circuit is quite conventional, using a long-established 723 regulator chip (IC1) with a pair of power transistors to boost output. Q1 is a medium-power TIP32A PNP device,

and Q2 a 2N3055 "workhorse" NPN power device. The two are connected in the complementary-Darlington configuration, which gives high current gain combined with a low "dropout" voltage - ideal for this kind of application.

The voltage divider, formed by R5, VR1 and R6, with R3 across its upper leg, is used to feed back a proportion of the output voltage to pin 4 of the 723. This is the inverting input of an internal error amplifier. The non-inverting input pin of the same amplifier is pin 5, which is fed with an internally generated reference voltage from pin 6 via R1. The error amplifier compares the two, and corrects the 723 output voltage at pin 11 to maintain the two in balance.

VR1 therefore forms the output voltage adjustment for the circuit, and is used to set it accurately to 13.8V.

Resistor R1 connected in series with the reference voltage fed to pin 5 of the 723 is to match the effective source impedance of the feedback divider driving pin 4. It is this balancing which gives the circuit's output regulation excellent temperature stability.

Both Q1 and Q2 have 100 ohm resistors connected between base and emitter, to minimise leakage at higher temperatures. This could otherwise degrade the regulation characteristic.

The output of the regulator is heavily bypassed via C4 and C5, to ensure good transient response and also make sure

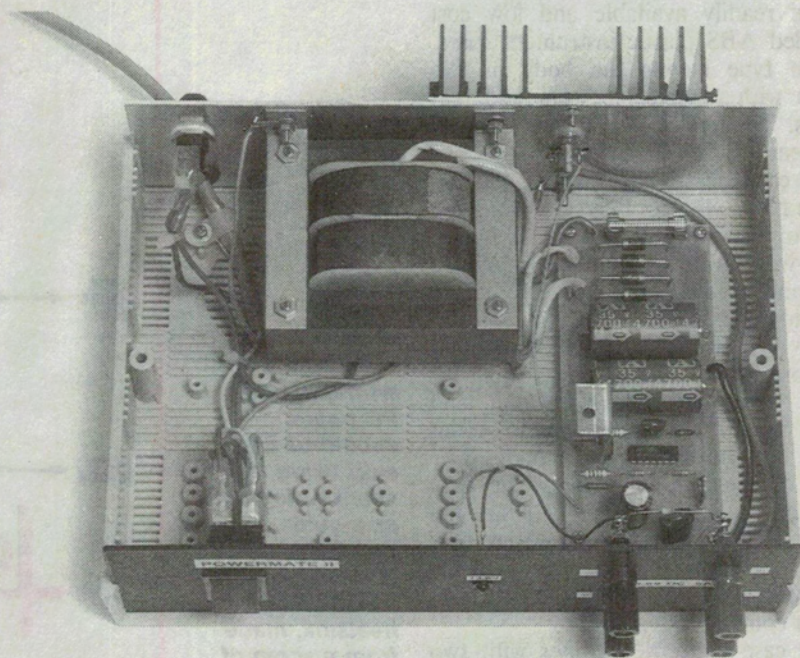

A general view inside the case, showing the very simple construction. The power transformer just fits inside the plastic case, over on its side as shown.

# Powermate II

that the supply's output impedance remains low even at high audio and radio frequencies.

Zener diode ZD1, a 16V/1W type, is used as a relatively crude but quite effective form of over-voltage protection. If for any reason the regulator circuit malfunctions and the output voltage tends to rise above 16 volts, ZD1 will draw very heavy current and blow the 5A fuse. This will also tend to occur in the event of a potentially dangerous high voltage being applied from the external load circuit.

Resistor R7 drives optional LED1, which provides an indication of the presence of 13.8V output from the supply. In a sense, this is a second "pilot light", and may therefore seem redundant. However its presence also tends to make the supply self-diagnosing in the event of a fault. If the mains switch pilot neon is on, indicating that input power is present, but LED1 is dark, obviously there is a problem with the low-voltage section of the circuit. Possibly the 5A fuse has blown, for example.

Two pairs of output terminals are provided, to allow the connection of two pieces of equipment if required. These can then be switched on and off via their normal low-voltage power switches, or left on continuously in the case of low-drain equipment.

## Construction

The complete supply is housed in one of the readily available and low cost moulded ABS plastic instrument cases, of the type having the body in two halves with removeable front and rear panels. This makes for a very compact and neat little unit.

The case measures 258 x 84 x 190mm, and is fitted with cooling slots along the sides of the top and bottom. It is also fitted with an array of internal moulded slots and pillars, to support PC boards in various positions.

For this project most of the circuit components are mounted on a small PC board measuring 140 x 60mm, and coded 88ps10. This is designed to mount in the bottom of the case, supported by some of the internal pillars. The only parts not mounted on the PCB are the power transformer T1, the series pass power transistor Q2, the mains switch and fuseholder, zener diode ZD1, LED1 and of course the terminals.

The case concerned comes with two moulded ABS panels, plus a 2mm-thick aluminium panel. This works out quite

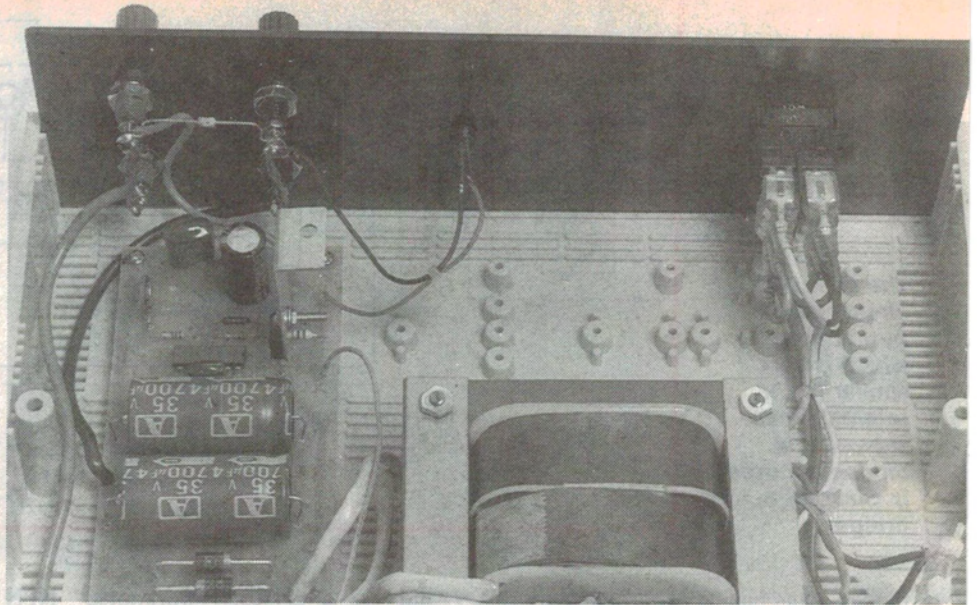

**A close-up inside, looking towards the rear of the front panel to show the terminal, LED and power switch wiring.**

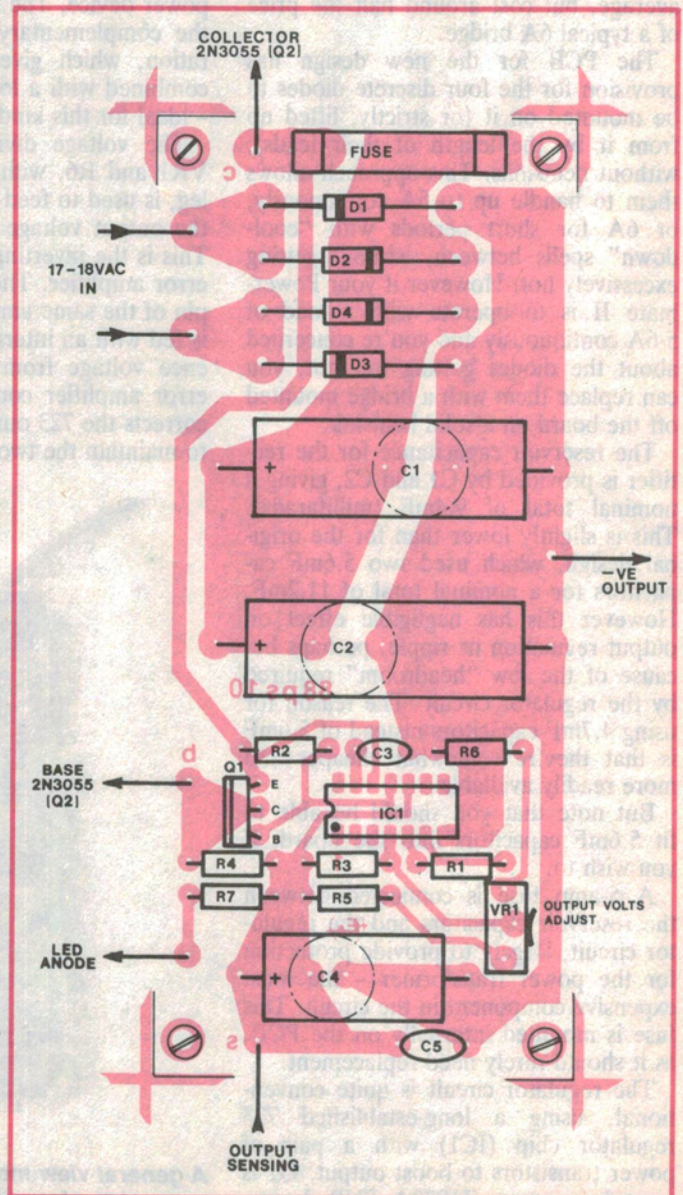

**Wiring up the PC board should be very easy using this overlay diagram as a guide. Note that transistor Q1 is fitted with a small 'flag' heatsink, made from a scrap of sheet aluminium.**

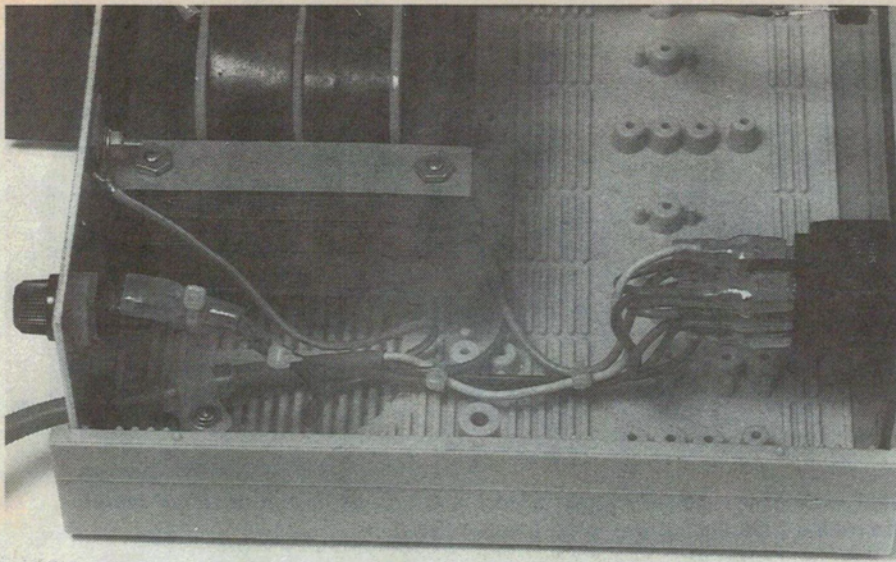

**Another close-up view of the inside, showing the mains wiring. Note the sleeving over all connections, to prevent accidents.**

nically, as the aluminium panel can be used at the rear, to support the power transformer and heatsink for Q2, while one of the ABS panels can be used for the front.

By sheer luck, perhaps, the readily-available 18V/6A power transformer (DSE 2000 or similar) just fits inside this case when mounted on its side and located as shown in the photographs. Only a single one of the case's internal pillars needs to be "pruned" to clear it - that inside the upper half of the case, at the centre rear. The transformer just fits between those on the bottom half, almost as if it was designed that way! It attaches to the aluminium rear panel via four 1/8" countersunk-head screws, lock-washers and nuts.

Similarly, by a similar stroke of good fortune, a standard 74-mm length of one of the common aluminium finned heatsink extrusions (110 x 33mm) just fits on the outside of the rear panel as shown, if you chamfer its edges slightly with a file to clear the lips of the case top and bottom. It attaches to the panel via a pair of 1/8" screws and nuts, one each centrally top and bottom.

Both panel and heatsink are drilled with the usual mounting and pin clearance holes to suit the TO-3 case of the 2N3055, which is mounted via the usual mica washer (smear lightly with silicone grease), stepped insulating washers, screws and nuts.

The only other items on the rear panel are the mains fuse holder and the mains cord entry, via a suitable grommet.

On the front panel there are again

only a few items to mount: the mains power switch SW1, the low-voltage indicator LED1, and the four output terminals with the protective zener diode ZD1 connected across the top pair. This makes assembly quite straightforward.

In fact the only slightly tricky part is cutting the rectangular hole to suit SW1. Too small and it simply won't fit, too large and it will be sloppy and move around. Still, if you do mess up the first ABS panel, there's always that second one supplied with the case, as a back-stop! (No, I didn't need it myself - apparently Murphy's Law wasn't looking that day!)

Returning again to the PCB, this has been designed to allow a reasonable amount of flexibility when it comes to components. Particularly for the electrolytic caps C1, C2 and C4, as these are sometimes difficult to get in either the PCB-mount (RB) type or the more conventional axial lead type.

To cope with this sort of problem, I have designed the PCB to take *either* type of component, for all three parts. PCB-mount parts mount via the two inner holes for each position, while axial types use the two outer holes.

As you can see from the overlay diagram and the photographs, the rest of the PCB is fairly straightforward. Power diodes D1-D4 are spaced apart to allow reasonable ventilation, with as much copper as possible connected to their pads to allow good conduction of heat as well as current.

Output adjust trimpot VR1 is placed at the edge of the PCB, so that if desired a small hole could be made in the

side of the case to allow screwdriver adjustment. But this probably isn't necessary, as once the output is set to 13.8V the trimmer really doesn't need any further adjustment.

## Assembly

As usual, it's probably a good idea to start with the PCB. After checking it for etching problems such as fine bridges or hairline cracks in conductors, fit the low-profile passive parts such as the resistors, polyester caps and fuse clips.

Note that some of the PCB-mounting fuse clips available are plated with a metal (chromium?) which seems to be almost impossible to solder. If you're unlucky enough to get some of these, you'll find you have to scrape or file off virtually ALL of the plating from the mounting lugs, in order to get a good bond to the board copper. I write from unhappy experience!

Next add the electrolytic caps to the PCB, noting their correct polarity. By the way, it is most important with this project to make solid, low resistance joints for all connections carrying high current. Pay particular attention to the leads of D1-4, C1 and C2, the transformer leads, the negative lead from the PCB to the output terminals and the collector and emitter leads for Q2.

Next add the trimpot VR1, and rectifier diodes D1-4. These are not mounted flat against the board, but spaced up from it to allow better ventilation and reduce board heating. The diode leads are left full length, and pushed through the board only about 4mm - sufficient to make good soldered joints.

To complete the PCB wiring add the regulator chip IC1 and transistor Q1, making sure you orientate them both correctly as shown in the overlay diagram. Q1 is again not forced down too near the board, as this would strain its leads. Leave it standing vertically, with the lower edge of the body about 10mm from the top of the PCB.

Although Q1 doesn't get very hot, you may care to attach a small "flag" type heatsink bracket to its top lug, as shown in the pictures. This will make sure that it stays cool at all times.

Having finished the basic PCB assembly, I suggest that you drill the rear panel and mount the power transformer and heatsink extrusion. At the same time drill and ream out the holes for the mains fuse holder and the mains cord entry grommet.

Note that a solder lug should be

## Powermate II

mounted under the upper transformer mounting nut on the fuse holder side, for connection of the mains cord earth. To ensure a good reliable connection, use "star" lockwashers on each side of the solder lug.

You should now be able to mount the power transistor Q2 on the heatsink/rear panel assembly, using the normal mica washer and insulating washer system. Don't forget to fit a solder lug under one of the case mounting nuts, to make the collector/case connection to

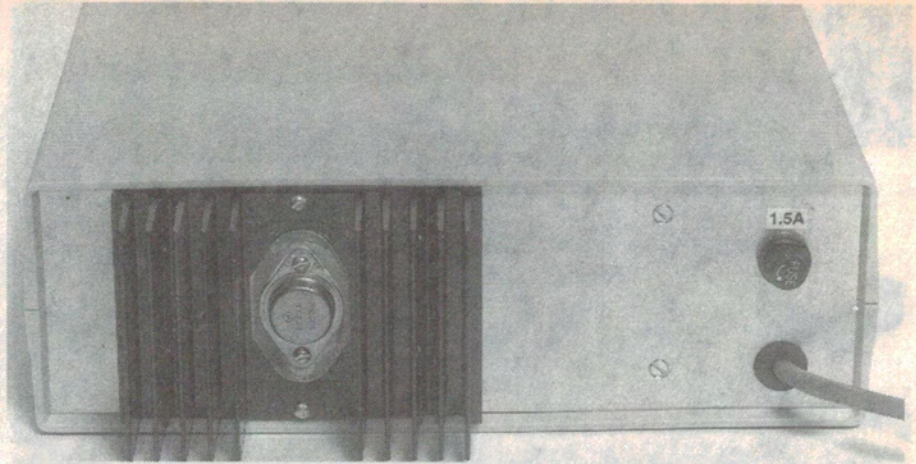

Rear view of the power supply, showing Q2 on its finned heatsink radiator, the mains fuse and grommeted cable entry.

### PARTS LIST

- 1 Moulded ABS case, 257 x 83 x 190mm, with moulded ABS and 2mm aluminium panels
- 1 PC board, 140 x 60mm, code 88ps10
- 1 Power transformer, 18V at 6A
- 1 DPDT illuminated mains switch
- 1 Finned heatsink section (single sided), 110 x 33 x 74mm
- 1 3AG fuse holder and 1.5A fuse
- 4 Screw terminals (2 red, 2 black)
- 1 3-wire mains cable and 3-pin plug

### Semiconductors

- 1 723-type regulator IC
- 1 TIP32A medium power PNP
- 1 2N3055 power NPN
- 4 1N5404 or similar 3A diodes
- 1 1N4745 or similar 16W 1W zener
- 1 5mm red LED and bezel

### Capacitors

- 2 4.7mF 35VW electrolytic
- 1 1mF 16VW electrolytic
- 1 0.1uF metallised polyester
- 1 0.22uF metallised polyester

### Resistors

- 2 100 ohm 1/4W 5% carbon
- 1 680 ohm 1/4W 5% carbon
- 1 1.5k 1/4W 5% carbon
- 2 3.3k 1/4W 5% carbon
- 1 15k 1/4W 5% carbon
- 1 1k linear trimpot, vertical PCB mount

### Miscellaneous

- 2 x PCB-mount fuseclips; 5A 3AG fuse; 2 x solder lugs; flag heatsink for Q1; P-clamp for mains cable; grommet for cable entry; 3 x cable ties; light and heavy multi-strand hookup wire; mica washer for mounting Q2; silicone grease; insulated mounting washers for Q2; screws, nuts, lockwashers, etc.

Q2.

It's a good idea to check the insulation between the case of the transistor and the heatsink when you've finished, to make sure there are no shorts. Now's the time to find this sort of problem and fix it, before you wire Q2 into circuit.

The next step is to drill the holes in the front panel for the output terminals and LED bezel, and cut the rectangular hole for the mains switch. As noted earlier it's a good idea to take care with this, as the hole has to be quite accurate if the switch is to mount firmly and reliably.

Now you can mount the above items on the front panel, and begin final assembly.

First connect a 150mm length of light multi-strand insulated hookup wire to the "b" pad on the PCB, and 100mm lengths of the same kind of wire to the "s" and "LED anode" pads. Then connect an 80mm length of heavy multi-strand insulated wire (red) to the "c" pad, and a 180mm length of similar wire (black) to the "negative output" pad. These will all be needed to make the connections from the PCB to the power transistor, terminals and LED.

Then carefully prepare the heavy 18V secondary leads from the transformer, and connect these to the "18V in" pads on the PCB. You can then mount the rear panel and PCB into the lower half of the case, fitting the PCB via four of the supplied self-tapping screws.

Now you can finalise the remaining low voltage connections, to Q2 and the front terminals. Don't forget the lead between the emitter pin of Q2 and the positive output terminals, which should again be made in heavy multi-strand insulated wire (red).

The 16V zener diode mounts directly between the two upper output termi-

nals, as shown in the pictures. Make sure you connect it the correct way around, with its "hand" end to the positive terminal. A reversed connection here could cause the zener to be destroyed when power is applied.

The output voltage sensing wire from the front of the PCB ("s" pad) also connects to the top "+" terminal, to ensure that it compensates for any voltage drop in the internal wiring between Q2 and the terminals.

Note that the connection from the negative (cathode) side of LED1 connects to the top "-" terminal, rather than to the PCB. This is simply for convenience.

The final phase of assembly is the wiring on the mains side of the transformer. As usual this should be done carefully to ensure reliable and safe operation.

The mains cable is clamped firmly to secure it, just after it enters the grommetted rear hole. Use a nylon "P" clamp for this, with a flat washer under the screw to ensure a firm purchase. The self-tapping screw mounts into the nearest moulded pillar.

After clamping the earth wire of the cable (yellow/green) is taken directly to the solder lug provided previously under the transformer mounting screw, to ensure reliable earthing of both the transformer frame and rear panel. The active (brown) and neutral (blue) wires are fitted with insulated spade-lug or "fast-on" connectors, to mate with the two uppermost lugs of the power switch.

The brown lead from the transformer primary is connected directly to the side lug of the fuse holder, with a small length of insulation sleeving to prevent inadvertent shocks. On the other hand the blue lead is connected to another in-

The PCB pattern, reproduced here actual size to allow tracing or photography if you wish to make your own.

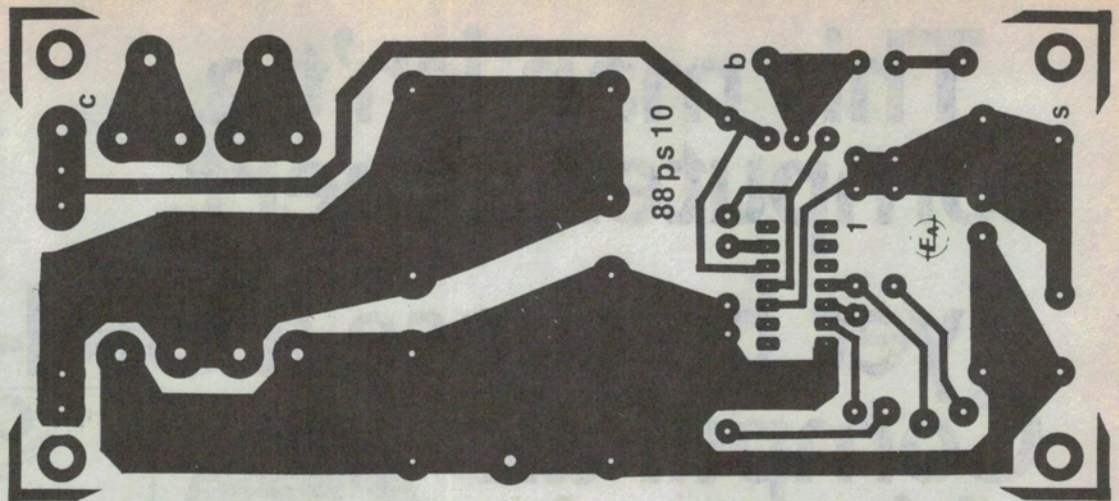

insulated fast-on connector, along with another 50mm length of similar mains-insulated wire. The other end of this second wire is then fitted with a further fast-on connector, again with insulating sleeve.

Finally a 180mm length of mains-insulated wire (brown or red) is connected to the rear (axial) lug of the fuse holder, again with an insulating sleeve. The other end of this wire is then fitted to another insulated fast-on connector, along with another 50mm length of the same wire. As before the other end of this short length is fitted with the final fast-on connector.

The purpose of these short wires is to connect to the neon pilot lamp inside the mains switch. The connections to the pilot and its internal series resistor are brought out to the two lower lugs of the switch (if you've mounted it correctly), so the two short wires connect to these. This leaves the centre lugs for the two two-wire fast-on connectors, from the transformer and the fuse holder.

Push all fast-on connectors firmly onto the switch lugs, and make sure that the insulating sleeves cover them properly for safety.

The final step with the mains wiring is to use three cable ties to bind the wiring together, as shown in the photographs. This not only makes for a tidier job, but also ensures that if any of the wires should break off from its connection, the other wires are likely to prevent it from moving away and perhaps coming into contact with the low-voltage wiring.

That's about it. Your Powermate should now be ready to fire up, and perform the only necessary adjustment – checking its output voltage.

Before plugging into the mains, set the voltage adjust trimpot VR1 to the centre of its range and move mains switch SW1 to its "off" (upper) posi-

tion. Then plug in and switch on the power at the outlet.

The neon lamp inside SW1 should remain dark. If it's glowing, you've mounted the switch upside down, and it will have to be reversed.

Assuming all is well at this stage, switch on SW1 and the neon should glow. LED1 should also glow, indicating the presence of low voltage.

If LED1 doesn't glow, there are two likely reasons. You may have reversed the connections to the LED itself, preventing it from operating, or perhaps reversed the connections to the zener diode ZD1. In case of the latter, switch off FAST – you may be able to prevent destruction of the diode, although this is being optimistic. You may have to replace the diode.

On the other hand if it's just a matter of the LED connections, simple reversal will solve the problem and you can turn on again.

Once LED1 glows properly and everything seems in order, connect a multimeter or DMM to one pair of output terminals and check the exact voltage. Odds are it won't be exactly 13.8V, but hopefully somewhere near it. A small adjustment with VR1 should allow it to be set exactly.

Your Powermate should now be complete, and all that remains is to screw on the top of the case.

A few final comments on the unit's current handling capability. Basically as it stands, it can deliver 13.8V at 5 amps continuously, providing the case and rear heatsink have access to reasonable air flow via the vents and fins. However with a continuous 5A load the main heatsink and rectifier diodes will get quite hot, even though the components are working within their ratings.

Without modifications it will also deliver 6 amps for short periods, providing

Q2 and the rectifier diodes have reasonable periods in between to "cool down". So it can probably still be used to power mobile equipment which draws up to 6 amps, but only say when transmitting for brief periods.

To make it capable of delivering 6A continuously, I recommend that you replace the diodes D1-4 with a suitably rated bridge, preferably mounted on the inside of the rear panel for improved heat dissipation. I would also recommend that you increase C1 and C2 to 5.6mF or 6.8mF, to beef up their storage capacity, and add a second 2N3055 power transistor, to share the load.

If you do this, you can't just connect the second transistor in parallel with the first. So that the second transistor does

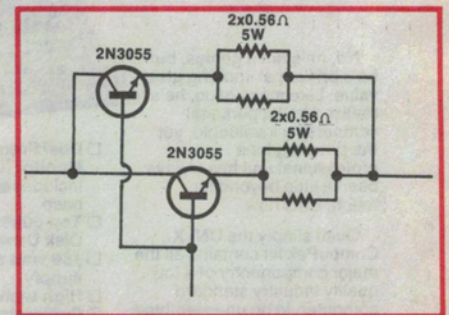

How to wire up a pair of 2N3055 transistors, for higher current.

indeed share the load current, you'll need to fit both transistors with low-value power resistors in series with their emitters. This is shown in the small auxiliary diagram.

As you can see, each emitter lead has a pair of parallel-connected 0.56 ohm 5W resistors connected in series. The collectors and bases are connected directly in parallel.

The two transistors should ideally be mounted on separate heatsinks, to dissipate the additional heat.