

CIRCUIT SURGERY

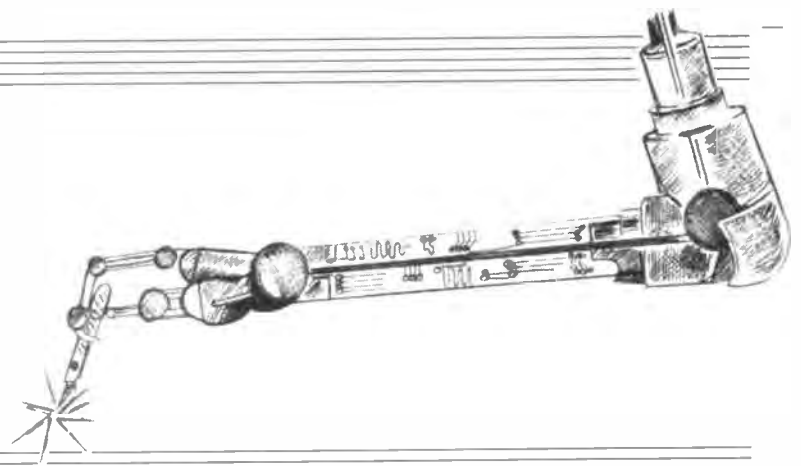

**ALAN WINSTANLEY
and IAN BELL**

Our team of Surgeons tackles a further range of readers' queries, sent in by post or E-mail. We look at thyristor basics, re-visit the topic of mains earthing, check out capacitor fundamentals, and more besides in our monthly help-desk round-up.

LET us sift through this month's post-box, starting with this query concerning the use of thyristors:

Gate Post

How can you calculate the required pulse and duty cycle width for triggering the gate of an SCR or triac? Satish Kumar (by E-mail).

An SCR (silicon controlled rectifier) or thyristor is a four-layer *pnpn* device (*p* and *n* type semiconductor) as shown in Fig.1a. Compare this with a bipolar junction transistor (b.j.t.) which is three-layer – either *pnp* or *npn*.

The thyristor can be thought of as two overlapping transistors – the *np* of a *pnp* transistor overlapping the *np* of an *npn* type, as indicated by the dotted boxed in Fig.1a. This leads to the transistor equivalent circuit in Fig.1b.

The circuit symbol of a thyristor is shown in Fig.1c. It is based upon that of a rectifier, which is a unidirectional device, meaning that current will only flow one way. The symbol for a triac is shown in Fig.1d.

The illustration in Fig.2 shows a basic thyristor circuit. Assume the thyristor, CSR1, is not conducting (no anode-cathode current), and also that no gate current is flowing. When the control unit produces a trigger pulse, a small gate current causes a much larger anode-cathode current to flow.

However, unlike a transistor which turns off again if the base or gate current is removed, the thyristor's anode-cathode current *continues to flow*. It will only stop when the load supply voltage is removed or if the anode-cathode current drops below a certain minimum level. Thus the trigger current causes the thyristor to latch on.

We can understand this behaviour by looking at the equivalent circuit of the thyristor in Fig.1b. The "trigger" gate current turns on transistor TR1. The collector current of TR1 provides a base current for TR2, turning it on too. In a similar manner the collector current of TR2 provides more

base current for TR1 turning it on even more. This is a positive feedback effect that quickly ensures that both transistors are on.

Once this condition has been triggered by the gate it is self-sustaining, so gate current is no longer needed. The thyristor can only be turned off by reducing its anode-cathode current below some critical point, known as the *holding current*.

The voltage across a thyristor when it is ON typically has a minimum value of around 1V, but may be higher (2V to 3V) for high current devices; the ON current can be very high (tens of amps in high power devices). The OFF current is very small – a leakage current. The maximum OFF voltage (supply voltage) can be very high – hundreds of volts in high power devices.

Consultation

To answer your question specifically, we have to consult the data sheet for the device we want to use. There are a large number of thyristors to choose from, but we will use the BT149B as an example.

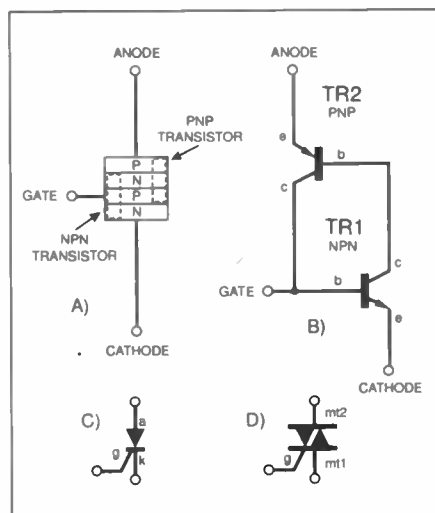

Fig.1. (a) Four layer pnpn construction of a thyristor (SCR), (b) equivalent circuit, (c) circuit symbol for an SCR and (d) for a triac.

This is a general-purpose low power device from Philips, intended to be interfaced directly to logic i.c.s and other low power trigger circuits. The BT149B can handle OFF voltages of about 200V and average ON currents of about 0.5A.

We need to consult the switching information – turn-on and turn-off times. For the BT149B, the turn-on time is typically 2μs and the turn-off time is typically 100μs. The trigger pulse must be long enough to allow the device to turn on (2μs in this case).

The duty cycle depends on when we expect the device to turn off – the trigger should have been removed by this time or the device will re-trigger. On this basis the shortest cycle possible would be 102μs (2μs on, plus 100μs off), but this assumes the thyristor is switched off at the same time the trigger is removed, which is not usually the case.

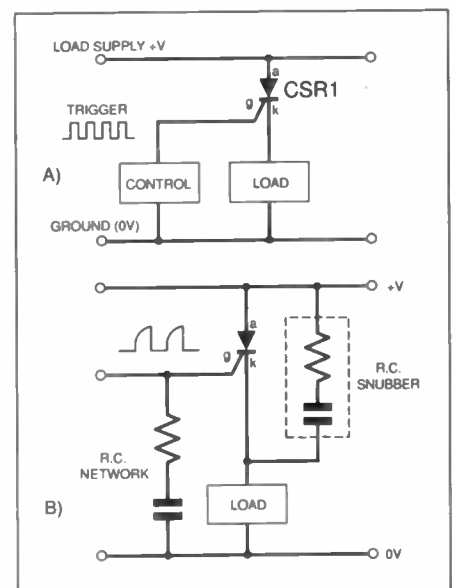

Fig.2. (a) Basic thyristor circuit. Thyristor CSR1 remains in conduction once a suitable triggering signal has been received. (b) The addition of external RC "snubbers" helps avoid false triggering.

Usually the trigger is a short pulse that is long enough to guarantee triggering and the time between pulses is determined by the control circuitry that generates the trigger, which of course depends on the application.

Note that thyristor switching times are different for different devices – compare the 2N5064 from Motorola (also rated at about 200V, 0.5A) for which turn-on takes about 3 μ s and turn-off 30 μ s.

The gate current is, unfortunately, not the only way to turn on a thyristor. A sufficiently fast rising anode-cathode voltage can also trigger the device, due to the capacitances inherent in the thyristor's structure. To prevent this, RC "snubber" circuits can be used to reduce the rise-time of voltages across the thyristor, as shown in Fig. 2b and similar treatment may be made on the gate terminal in some cases.

Incidentally, unwanted (or *parasitic*) thyristor structures can occur in CMOS chips. Integrated circuit fabricators and chips designers take care to make sure that these unwanted thyristors cannot switch on, because if they do they "crow-bar" or short-circuit the power supply with disastrous consequences. The problem is known as *latchup*.

Triac

By placing two thyristors "back-to-back" (in inverse parallel), a *triac* is formed, which is suitable for use with a.c. control circuits (a.c. load control, sound-to-light systems, etc.) because current can flow through it in either direction between the two terminals (Main Terminals 1 and 2). Similar arguments would apply to the switching times of the trigger pulse – it helps to consult the data sheet for details. Note that a trigger pulse has to be provided for each phase of the waveform.

Look out also for a *diac* – a bi-directional diode with special characteristics, which may be used for triggering triacs into conduction. *IMB*.

Stripboard and High Voltages

Stripboard prototyping board, of which Veroboard is the best-loved brand, is the ideal medium for developing simple discrete circuits. Although many prefer to develop printed circuit boards using a CAD system, there is still much to be said for the convenience and adaptability of good old stripboard, especially if the circuit has not been finalised.

Provided the circuit is not too complex, stripboard makes it easy to add components or make other changes during the development process. It's also ideal for beginners and is perfectly adequate for constructing many projects in their final form, and has been for thirty years or so.

It does raise questions of safety, though, when used with mains voltages:

I sometimes use stripboard for projects rather than spending time making printed circuit boards. These can involve 230V a.c. mains voltages. Can anyone provide details of the maximum load capacity of copper strips? (Posted by Murray Cameron in the EPE web site Chat Zone.)

Stripboard is now made by several manufacturers of which Vero is the most

famous, but it also comes from Far Eastern sources. This means there is no across-the-board (sorry) standard specification. However for typical 0.1in. matrix stripboard, assume a maximum current of no more than roughly 5A. The breakdown voltage between strips is said to be about 800V peak, absolute maximum.

You can use stripboard with mains voltages provided the following precautions are used:

1. Ensure all stand-off pillars are non-conductive types with no possibility of a chassis or mounting screw being in contact with the mains voltage. *Use fully insulated nylon mounting hardware.*
2. If a break needs to be made in mains-carrying copper strips, make at least *three continuous breaks* adjacent to each other to completely remove all copper from that section of the board and fully isolate the mains strip.
3. Mains-carrying strips can be reinforced by soldering a length of tinned copper wire along the strip.
4. It is best to use p.c.b. screw-terminal blocks to make a safe mains-voltage "flying lead" connection.

It is preferable to use a quality branded product for circuitry involving mains currents. It is probably far safer to keep any heavy mains currents off the board, and use suitably rated fully insulated hook-up wire instead. *ARW*.

Live Supplies

It's back to the topic of Live, Neutral and Earth. What do these designations actually mean?

There are three parts to an a.c. socket labelled "hot" or Live, Neutral and Ground. I'm trying to make sense of what these mean. Can someone provide a good explanation of the concept of "Ground"? asks HMB via the Internet.

The meaning of "Ground" depends on its context. In an electronic circuit "ground" nearly always means "0V" and anything "grounded" is connected to 0V.

Elsewhere in the circuit diagram (say in the power supply section) the 0V rail will be shown as connecting to "ground", in the same way that the negative pole of a car battery may be depicted as connected to the "chassis." It saves cluttering up wiring diagrams with lots of lines. In a circuit, a ground symbol usually just means that everything with the ground symbol is connected together.

This does *not* usually mean that the 0V rail is directly connected to physical earth (soil), which is the second meaning of "grounding", although the 0V rail may sometimes be connected to the ground as well. The term "ground" as used in the USA is synonymous with "earth" in the UK and Europe. In an electrical installation, grounding means, physically connecting to earth (soil).

Regarding why the mains supply is labelled the way it is, Fig. 3 shows a typical mains supply which would be fed to a domestic installation by an underground cable. At the "power supply" end (e.g. the transformer/sub-station), the neutral is firmly connected to the earth. This is "grounding" in the electrical sense of the word, and it implies that the neutral and earth wires are linked. In the USA, the neutral is the *grounded* conductor whilst the earth wire is the *grounding* wire: live is the *ungrounded* wire.

The live wire alternates between +325V peak and -325V peak. A quick calculation of $325/\sqrt{2}$ gives a value of 230V r.m.s. (the "official" UK mains value). Because of the way in which three-phase electricity is generated, the neutral point has no voltage and the live wire is the one which carries a potential. Appliances are therefore connected between live and neutral at the domestic installation.

Hot Line

The term "hot" is American slang for "live". If you, as a human being, were to touch a live wire, then assuming that you are in contact with the ground, a potentially lethal current would flow from the "hot" or live, through your body and to earth. This is because the earth is connected to the neutral as shown in Fig.3 and so the "escaping" current will seek to complete a circuit back to the neutral point through the earth.

If an RCD (Residual Current Device) – also known as an ELCB (Earth Leakage Circuit Breaker) or GFCI in the USA (Ground Fault Circuit Interrupter) – is installed then the current flowing to earth will be detected, and a high-speed trip switch will operate to hopefully prevent injury. *Without* the benefit of such a device, a fatal shock may be received.

The purpose of the ground/earth connection is to provide a very easy path for leaking current to "escape" through. If an insulation fault arises and a live wire happens to touch exposed metal work, then instead of the user receiving a shock when he touches it, a large current will flow straight to ground and either melt a fuse or trip an RCD.

(The LM1851 is a National Semiconductor chip which forms the heart of a GFCI, should advanced readers care to consider making their own, perhaps for incorporation into a mains-powered project.)

Regular readers may recall that the subject of mains earthing came up approximately 18 months ago (see June and Oct. '97 *Circuit Surgery*), and at the time my

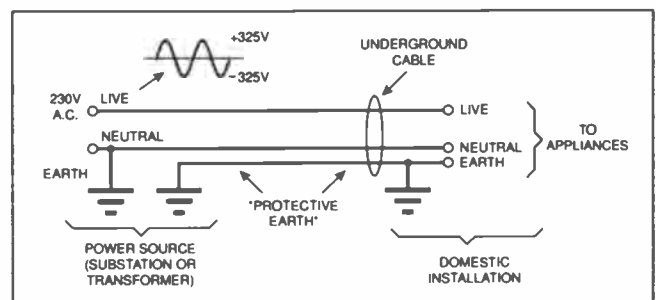

Fig.3. How the Live, Neutral and Earth terminals of a domestic installation are connected to the incoming supply. The "Protective Earth" may not be present in overhead supplies.

simple one-liner reply provoked as many questions as it answered. In spite of the attempts made to check the validity of the material beforehand, it soon became obvious that there were many misconceptions surrounding the way in which electricity was generated and delivered. In fact many of us know how to use the mains supply, but a great many more are not entirely sure where electrical power comes from to start with.

Next month I intend to set the record straight with the start of a two-part feature showing how power is generated and transmitted to the home. The author has spent many days as a guest of the renowned international power group National Power PLC (www.national-power.com) who generously provided the author with unrestricted access to an entire power station (National Power's Killingholme "A" gas-fired plant near Immingham in Lincolnshire), as well as several National Power engineers all of whom helped enthusiastically with the research.

The entire process from gas pipeline, to the turbines and generators all the way through to the provision of the domestic "230V" a.c. is described and illustrated in full. The feature will answer the above questions and more besides in greater depth: readers will find it fascinating stuff, so be sure to read *From Pipelines to Pylons* starting in the August 99 issue! ARW.

Currents and Dielectrics

I'm a frequent reader of EPE, and one of my favourite columns is Circuit Surgery. It's amazing how much one can learn from such articles, and fantastic that someone is ready to read and possibly answer queries that we newcomers to the world of electronics might have. (Thanks. The words "flattery" and "everywhere" spring to mind! We try to answer every query but we can't always promise a personal reply unfortunately.)

I've got three basic questions to ask:

- 1. Everyone knows that a capacitor conducts current briefly, but I don't understand how current can flow between two plates if they are separated by a dielectric.*
- 2. Can you help with the physical significance of logic gates? In particular, AND and OR gates. These are constructed with transistors but how is it that one can say that a particular circuit is an AND gate.*
- 3. Finally, what is the significance of "double insulation"?*

Regards to all at EPE! Karl Vassallo Grant from Malta, via the Net.

There's quite a lot to go at, so let's answer your queries in order. First, you are quite correct – the two capacitor plates are separated by an insulating layer, called a dielectric. Catalogues classify their capacitors by dielectric, because different types of dielectric (polyester, polypropylene, silver mica and so on) are more suited in some applications than in others.

Let us use the tried and tested hydraulic analogy; a battery becomes a tankful of water. Imagine an electrical circuit as being a sealed system, using water travelling via the tank and through a hosepipe. Imagine

also that the capacitor consists of a rubber diaphragm which is placed in the circuit. There is "solid" water in the hosepipe on both sides of the diaphragm, see Fig. 4.

Water cannot pass through the diaphragm, but it can "stretch" it. If we squeeze the hosepipe to compress the water, this forces the water up against the diaphragm which stretches "outwards".

Because it is a sealed system, the water on the other side has to go somewhere – so it's forced further around the hosepipe by the movement of the diaphragm. *Although no water passed through the diaphragm, never the less, water was seen to move around the circuit for a short time.*

A capacitor operates in roughly the same sense. In the "sealed system" of an electric circuit, electrons have to come from somewhere and go somewhere! A flow of electrons constitutes an electrical current. Adding a charge onto one plate of a capacitor (say, by "sucking" it from one pole of a

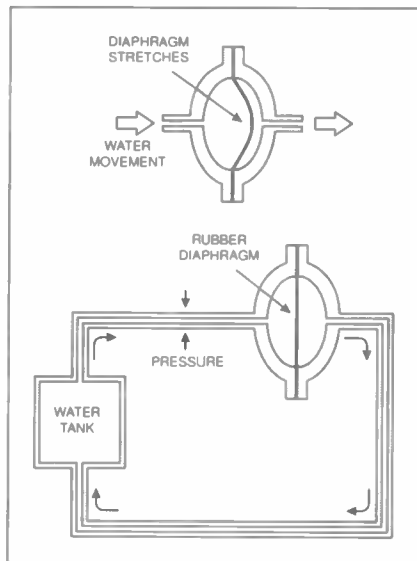

Fig.4. Using the tried and tested hydraulic analogy where the battery becomes a tankful of water and a capacitor the diaphragm. Water, sealed in a hydraulic "circuit", causes the diaphragm to stretch, which displaces water in the circuit. It appears that water has flowed "through" the diaphragm.

battery) causes a corresponding charge to be "sucked" from the other plate, and piled back on to the remaining pole of the battery.

It is a sort of electronics optical illusion, and is the reason why we say that capacitors can allow a current or signal to "pass" through. What we really mean is that a charge flows onto the capacitor on one plate, and a corresponding charge flows off the other side. Thus a current is seen to flow, even though there is a dielectric breaking the circuit. It's not possible to analyse this in greater detail without looking at the physics of the capacitor though.

In Truth

Your second query: I guess you are referring to the "Truth tables" of basic logic gates. These summarise how a logic gate will react with a particular combination of inputs. For example, an AND gate

output goes logic high when *all* its inputs are high; an OR gate goes high when *any* of its inputs are high. Other gates such as NAND, NOR and EXOR have their own unique truth tables as well.

These were fully described in our series *Teach-In 98 – An Introduction to Digital Electronics*, which was co-written with the University of Hull. See the November 1997 to September 1998 issues and *Back Issues* page for details. Logic gates and how truth tables work, were explained in Part Four (February 1998). Truth tables exist for more complex logic devices and will be found in manufacturers' data sheets, which these days are commonly available on the world wide web.

Double Insulation

Finally, "double insulation" merely implies that extra precautions have been taken by a manufacturer to fully insulate any live parts, and to make sure that there is no possibility of the user coming into contact with live wires. For reasons explained in the previous question (*Live Supplies*), the earth is used to provide a low-impedance route for any fault currents to flow. Extra insulation and the widespread use of plastic mouldings removes the possibility of any external parts ever becoming live (e.g. through a live wire coming adrift), so there is no longer a need to "earth" the equipment.

Double-insulated units carry a symbol of two concentric squares (check any mains adaptor to see) and have a two-core power cord. Typical examples of double-insulated equipment include power and garden tools, consumer video, TV and audio units, and most kitchen appliances. However, constructional projects which are mains-powered almost always have a compulsory earth wire, which will be connected to the mounting frame of the mains transformer and elsewhere.

All exposed metal parts including switches and bezels, metal panels and mounting screws, which can access the interior of a mains-powered project, must be properly connected to earth to guard against the possibility of them ever becoming live in the future. This protects you and other users from electric shock. ARW.

CIRCUIT THERAPY

Circuit Surgery is your column. If you have any queries or comments, please write to: Alan Winstanley, *Circuit Surgery*, Wimborne Publishing Ltd., Allen House, East Borough, Wimborne, Dorset, BH21 1PF, United Kingdom. E-mail alan@epemag.demon.co.uk. Please indicate if your query is not for publication. A personal reply cannot always be guaranteed but we will try to publish representative answers in this column.

ENTER THE CHAT ZONE

The *EPE Chat Zone* on our web site is now open as a way for readers to exchange information, views, hints and tips in virtually real time.

<http://www.epemag.wimborne.co.uk/wwwboard>

