

Cross coupled transistor bridge

THIS circuit shows a full wave rectifying bridge which has an off-set voltage an order smaller than conventional diode bridges.

The graph shows transfer characteristics for a conventional full wave silicon diode bridge in curve 1, a germanium diode bridge in curve 2, and the cross coupled transistor bridge in curve 3. The off-set voltage of the transistor bridge is about 30mV with good linearity above the knee.

The circuit was developed for use in a simple but sensitive field strength meter. The meter is protected by the base-emitter junctions of the transistors. With the devices shown, the frequency response is up to 30MHz and the optimum value of R_L is about 2k Ω .

L. D. Thomas,
Burton on Trent,
Staffs.

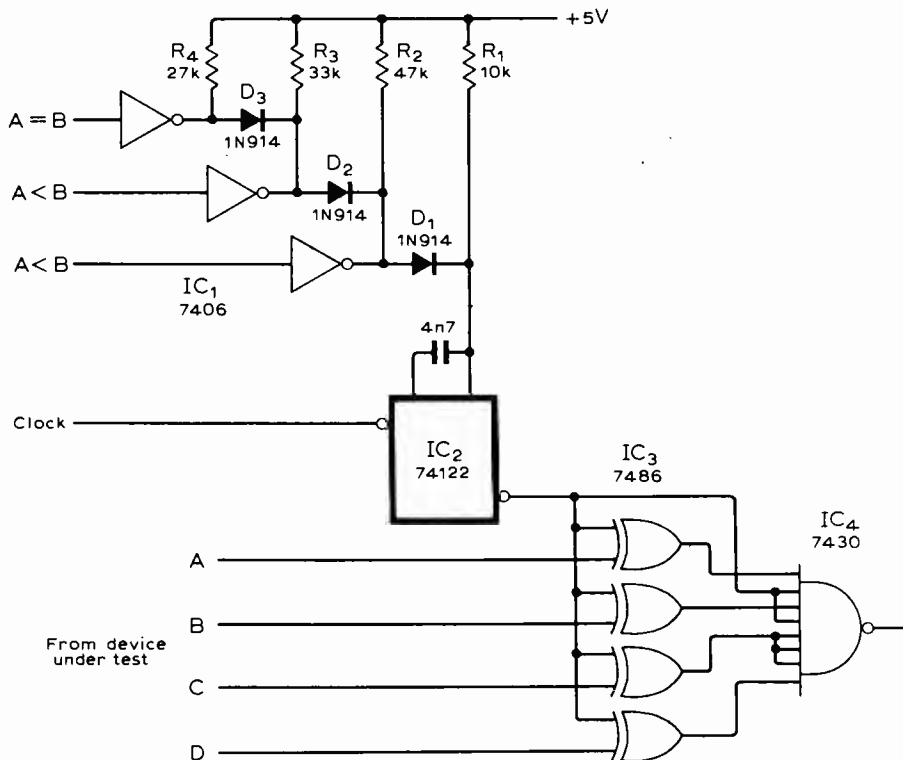
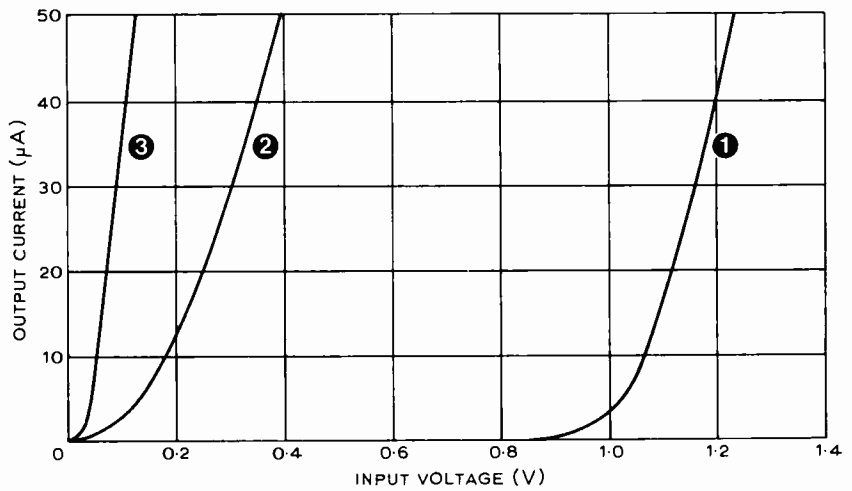
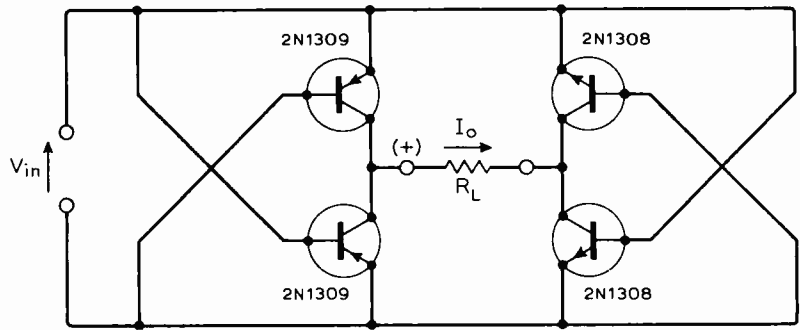

Programmable strobe

WHEN using magnitude comparators to evaluate the dynamic operation of digital counters, the output data for $A > B$, $A < B$, and $A = B$ is compared with a known conversion time for each bit by enabling exclusive OR gates with three separate strobe pulses. This circuit uses a monostable which, with the aid of three open collector inverting gates, will generate strobe pulses of 7.8 μ s, 10 μ s, 12 μ s, and a 15 μ s pulse to clear counters, etc.

The pulse widths can be increased or decreased by altering the value of C for the longest pulse and the three resistors in parallel for the three strobe pulses.

D. J. Greenland,
Cambridge.