

DESIGN NOTES

A Positive-to-Negative Voltage Converter Can Be Used for Stable Outputs Even with a Widely Varying Input – Design Note 433

Victor Khasiev

An obvious application of a positive-to-negative converter is generating a negative voltage output from a positive input. However, a not-so-obvious use is to produce a stable output voltage in an application that has a widely varying input. For example, a converter in a battery-powered device, which has an inherently variable input voltage, can produce a stable output voltage even if input voltage falls below the absolute value of the output voltage. However, an obvious drawback is reverse polarity, which can be easily overcome in this application. The supplied circuitry can use the negative output as the system ground and the negative battery terminal as the “positive” voltage source.

This topology is particularly useful when the input varies above or below the output. In such cases, a traditional step-down regulator would not be able to regulate once the battery voltage drops below the output, thus shortening the useful battery run time. Buck-boost solutions and other topologies such as a SEPIC solve this problem, but they tend to be more complicated and expensive. The positive-to-negative converter topology presented here combines the simplicity of a step-down converter and the regulation range of a buck-boost topology.

A new generation of Linear Technology high voltage synchronous step-down converters, such as the LT[®]3845, make it possible to implement positive-to-negative conversions for a variety of applications.

Basic Operation

Figure 1 shows a simplified block diagram of a positive-to-negative converter. Figure 2 shows an equivalent circuit, which helps in understanding the basic operation of the circuit in Figure 1. When transistor Q is on (Figure 2a), diode D is reverse biased and the current in inductor L increases. When Q is off (Figure 2b), inductor L changes polarity, diode D becomes forward biased, and current flows from inductor L to the load and capacitor C. The voltage across capacitor C and the load is negative, relative to system ground. Figure 3 shows a timing diagram.

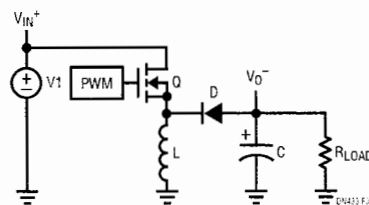

Figure 1. Simplified Block Diagram of Positive-to-Negative Converter

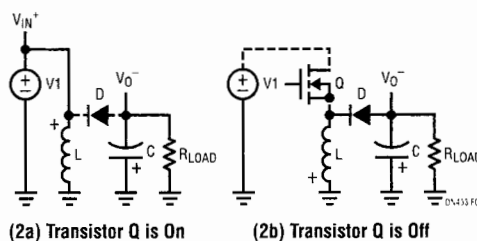

Figure 2. Equivalent Circuits Show the Operation of the Positive-to-Negative Converter

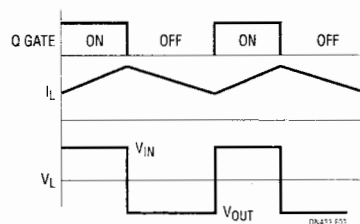

Figure 3. Converter Timing Diagram

The duty cycle range can be found from following expression:

$$D = \frac{|V_O|}{V_{IN} + |V_O|}$$

$$D_{MAX} = \frac{|V_O|}{V_{IN(MIN)} + |V_O|}$$

$$D_{MIN} = \frac{|V_O|}{V_{IN(MAX)} + |V_O|}$$

Component Stress in a Positive-to-Negative Topology

V_{MAX} is the maximum voltage across transistor Q and diode D (Figure 2), where:

$$V_{MAX} = V_{IN(MAX)} + |V_O|$$

The maximum current, I_{MAX} , through transistor Q, inductor L and diode D can be derived based on the following equations, assuming continuous conduction mode:

$$I_L = \frac{I_O}{1 - D_{MAX}}, \quad dI = \frac{V_{IN(MIN)} \cdot t \cdot D_{MAX}}{L}, \quad I_{MAX} = I_L + \frac{dI}{2}$$

where t is a switching period.

Circuit Description

Figure 4 shows a 9V to 15V input to -12V at 3A output converter. The high voltage LT3845 is used for several

reasons, including the ability of its SW pin to withstand 65V, its integrated high side driver and differential current sense. The LT3845 can also provide synchronous rectification, which allows the use of efficient MOSFETs over less efficient switching diodes.

The entire converter power path contains the LT3845 high voltage PWM controller, MOSFETs Q1 and Q2, inductor L1, diode D1 and output filter capacitors C_{OUT1} – C_{OUT3} . Diode D2 is a bootstrap diode and diode D3 provides bias voltage for internal MOSFET drivers.

Conclusion

Very often electrical engineers have to design a negative voltage source supplied from a positive voltage rail. The positive-to-negative converter discussed in the article can be a good alternative to a flyback or a SEPIC approach.

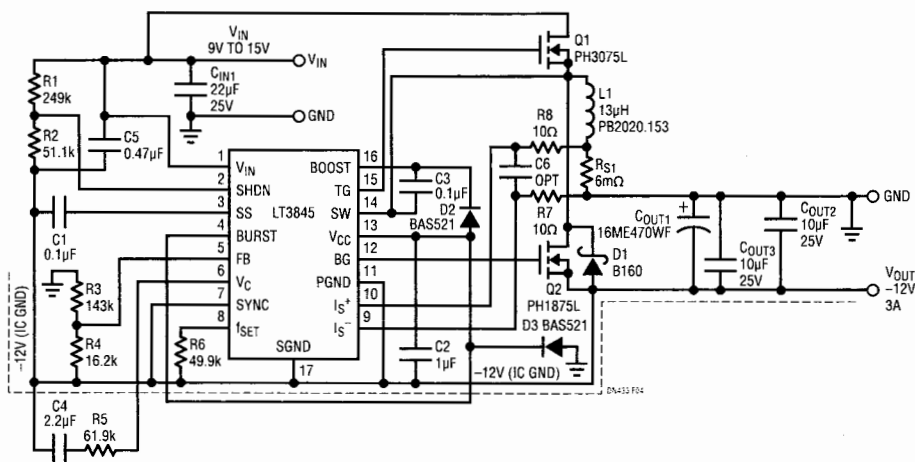

Figure 4. Conversion of 9V-15V into -12V at 3A Based on the LT3845 High Voltage PWM Controller

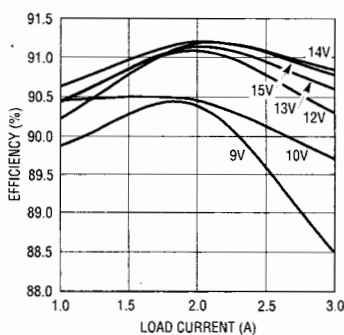

Figure 5. Efficiency for the Figure 4 Circuit with Varying Input Voltage to a Fixed -12V Output

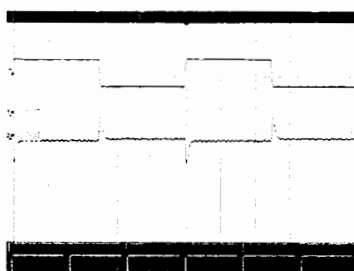

Figure 6. Transient Response to an Output Load Step of 1A to 2A

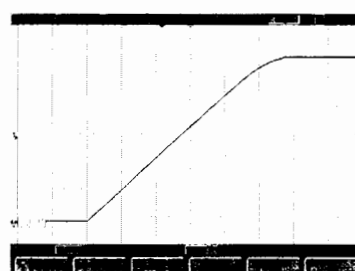

Figure 7. Start-Up Waveform for the Circuit in Figure 4 with $V_{IN} = 14V$, $V_{OUT} = -12V$, $I_{OUT} = 2A$

Data Sheet Download

www.linear.com

For applications help,
call (408) 432-1900, Ext. 3161