

High-Efficiency 3A Battery Chargers Use LM2576 Regulators

National Semiconductor
Application Note 946
Chester Simpson
May 1994



This paper describes two LM2576-based designs which provide up to 3A of current for battery charging.

3A Battery Charger Has Built-In Overcharge Protection

This design is a 3A battery charger intended for use with 5-cell Ni-Cd or Ni-MH battery packs (but can be modified to suit other numbers of cells). The circuit includes automatic shutoff that occurs when the battery temperature rises 10°C above ambient.

CIRCUIT CONCEPT

This battery charger shown in *Figure 1* was developed specifically for applications using either **Nickel-Cadmium (Ni-Cd)** or **Nickel-Metal Hydride (Ni-MH)** batteries that will accept a 3A fast-charge rate, and provides automatic shutoff of the high-current charge when the battery is full.

After shutoff, a continuous (low level) charge current is used to "trickle charge" the battery which keeps it topped off and prevents charge loss due to any internal leakage.

The trickle charge rate used must always be low enough that the amount of gas developed within the cell is small enough that it can recombine, thus preventing pressure build-up and venting (opening of the cell's internal vent to release pressure). The maximum safe trickle charging rate is determined by the size and type of battery (this is covered later in the paper).

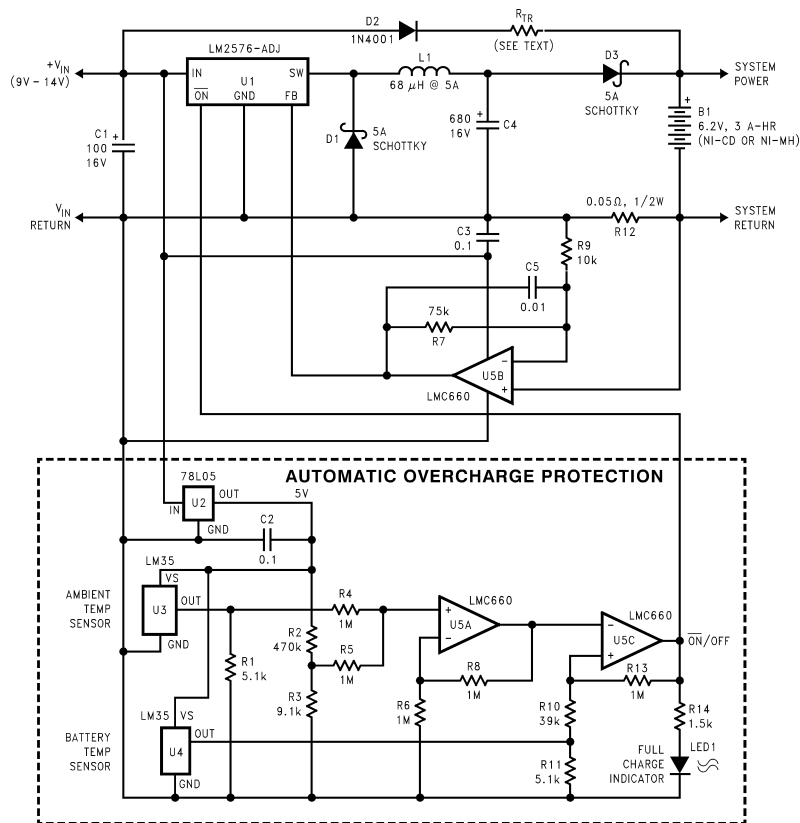

01205401

Notes (Unless Otherwise Specified):

All capacitance values are in µF.

All resistors are 5%, 1/4W.

U1 requires small heatsink ($R_{TH} < 15^\circ\text{C/W}$).

C1 and C4 must be low ESR aluminum electrolytic.

U5D is not used.

FIGURE 1. 3A Charger with Overcharge Protection

3A Battery Charger Has Built-In Overcharge Protection (Continued)

The critical specification for a battery is its **Amp-hour (A-hr) rating**, which is numerically equal to the maximum amount of current the battery can supply to a load for one hour before the cell reaches its **end-of-life voltage** (usually taken as 1.0V/cell for Ni-Cd and Ni-MH batteries).

When a battery is charged or discharged at a current that is equal to its A-hr rating, **this is known as the “c” rate**.

Most Ni-Cd and Ni-MH batteries can be safely charged at a 1c rate, as long as they are not overcharged. However, the battery temperature must be within a range of about 15°C to 45°C (the reasons are detailed later in this paper).

OVERCHARGING: THE SILENT KILLER

The nemesis of all rechargeable batteries is overcharge ... although some battery types tolerate it better than others, the results of overcharge range from minor damage to catastrophic failure.

In the case of Ni-Cd, which is the most popular rechargeable battery type presently in use, sustained overcharge causes increasing pressure within the battery that eventually causes the cell's vent to open and release oxygen. This has a detrimental effect on the battery, although it may still retain some useful capacity.

If Ni-MH batteries are overcharged, they will also build up pressure and release gas: however, the gas released will be hydrogen, which is extremely explosive near spark or flame. One battery manufacturer created an interesting euphemism for some of the unfortunate accidents in cases where Ni-MH batteries were overcharged: **Rapid Spontaneous Disassembly**.

DETECTING END-OF-CHARGE

There are several ways to detect end-of-charge for Ni-Cd or Ni-MH batteries, but one way that is both simple and reliable is called a ΔT detector. It measures both the ambient temperature and the battery temperature and cuts off the high current charger when the battery rises a pre-set amount above ambient. This design uses a 10°C rise as the cutoff point (which is recommended by most battery makers), but can be easily adjusted by changing resistor values.

Ni-Cd cells are perfectly suited for ΔT cutoff techniques, because their charge process is **endothermic** (they get slightly **cooler** when a discharged battery is being recharged). Even at fast charge rates, the battery will not begin to heat until it is nearly fully recharged. At that point, the battery is no longer converting the electrical current into a chemical reaction, so it must be dissipated as heat. The resulting increase in temperature provides a very accurate indicator that it is time to stop charging.

The Ni-MH battery is not quite as accommodating: the recharge cycle is **exothermic** (the battery gets slightly **warmer** during recharge) but still shows a fairly well defined increase in temperature when the battery is fully charged. Using a 10°C ΔT detection point will give good results in most cases, and is recommended by the battery makers.

NOTE: WARNINGS ABOUT FAST CHARGING NI-MH AND NI-CD BATTERIES

Since the Ni-MH battery normally gives off heat during recharge, the 10°C “window” may have to be adjusted to suit the characteristics of the specific cell: The window must be

wide enough to prevent premature cutoff from “normal” heating, but narrow enough to detect the temperature rise which occurs at full charge (and execute appropriate charge termination).

Any new design that uses Ni-MH batteries should be carefully evaluated to verify accurate end-of-charge termination because of the potential for battery explosion if hydrogen is released.

IMPORTANT: With Ni-Cd or Ni-MH cells, the 1c (fast) charge rate can only be safely used if the battery temperature is in the range of about 15°C to 45°C.

At **low temperatures**, gas recombination within NiCd and NiMH batteries does not occur as easily, which limits the amount of charging current that can be safely used before venting will occur. If low-temperature (<15°C) recharging is required, consult the battery maker for safe charging current levels.

A battery that is recharged at **elevated temperature** will retain substantially less energy than a battery recharged at 25°C. At high temperatures (>35°C) gas generation within the cell occurs at a much lower state of charge, meaning that the cell will not accept as much charge (compared to 25°C) for a given amount of cell temperature rise.

The poor charging efficiency seen at high battery temperatures means that extremely long recharge times (at low charging currents) are required to deliver full (25°C) capacity of charge to a “hot” battery.

TRICKLE CHARGE CURRENT

All batteries lose charge internally due to self-discharge, usually occurring due to leakage paths through the battery separators (insulators). The amount of leakage is dependent primarily on battery age and usage, with leakage increasing dramatically in batteries that are old or have completed many cycles of charge and discharge.

Trickle charging is a continuous low-level charging current that tops off the total charge in the battery, and prevents any energy loss that would occur due to leakage.

The **maximum safe trickle charging current for a typical Ni-Cd cell is about 0.1c**, this being the maximum charge rate at which all of the gas developed internally is able to recombine (so there is no internal pressure buildup that would cause venting).

For Ni-MH batteries, the maximum (safe) trickle charge rate is lower (one manufacturer specifies c/40). This is an important difference between Ni-Cd and Ni-MH batteries, and must not be exceeded for continuous charging.

In this design, the trickle charge current is provided by the resistor labeled R_{TR} (see *Figure 1*). This current flows any time V_{IN} is present, regardless of operation of the high-current charger. When the high-current charger is operating, the total charging current is the **sum** of the trickle current and the current provided by U1.

Once the input voltage V_{IN} and the desired trickle charge current I_{TR} are known, the value for R_{TR} is found using Ohm's Law:

$$R_{TR} = (V_{IN} - 7 - 0.7)/I_{TR}$$

The maximum power dissipation in R_{TR} must also be calculated (when selecting a resistor, make sure the power rating is greater than the value calculated below):

$$P_{MAX} (R_{TR}) = (V_{IN} - 4 - 0.7)^2/R_{TR}$$

3A Battery Charger Has Built-In Overcharge Protection (Continued)

Note that the power dissipation in the resistor is dependent on the battery voltage. As the battery voltage increases, the voltage drop across R_{TR} decreases (causing the power dissipation to decrease).

In the above equation, a battery voltage of 4V is assumed as a worst-case minimum value for battery operating voltage for a five-cell battery pack (which would provide the maximum power dissipation for R_{TR}).

A **good** 5-cell Ni-Cd or Ni-MH battery which is being trickle charged (after being fully recharged) will read about 7V, which will produce the *minimum* power dissipation in resistor R_{TR} .

DETAILS OF CIRCUIT FUNCTION (REFER TO *Figure 1*)

The 3A of charging current provided by the fast-charger is obtained from an LM2576, which is a buck regulator that switches at 52 kHz. Because it is a switcher, it allows the user the option of using a wider input voltage range and still retaining high power conversion efficiency (about 80% @3A with V_{IN} in the 10V–14V range).

The LM2576 IC (U1) is used to provide a charging current that is independent of the battery voltage. Whenever the ON/OFF pin is held low, U1 will source current into the battery through D3. A current-control feedback loop is established using U5B, R12, and associated components.

R12 is used as a current shunt, and it provides a voltage to the input of U5B that is proportional to the charging current. U5B functions as an amplifier with a gain of 8.5, which causes the output of U5B to be 1.23V when the current through R12 is about 2.9A. The 1.23V signal on the feedback pin of U1 will “lock” the loop at this value of charging current.

A fast-charge current value other than 2.9A can be set by adjusting the values of R7, R9, or R12. These values (which set the overall gain of the stage) should be adjusted so that the output of U5B is 1.23V at the desired amount of fast-charge current.

AUTOMATIC SHUTDOWN AT FULL CHARGE

The crucial part of fast charging a battery (especially if it is Ni-MH) is **knowing when to stop**. This design uses a ΔT detector that measures **both** the battery temperature and the ambient temperature, and shuts down the fast-charge current source when the battery is +10°C **above ambient**.

This method is superior to techniques which sense only battery temperature. Single-ended temperature sensing may not accurately measure charge: a “cold” battery will have to heat up too much before the detection point is reached (overcharging it), while a “hot” battery will terminate charge long before full charge has been delivered to the battery (because its temperature starts out too near the detection level).

Two LM35 temperature sensors (U3 and U4) provide output voltages of 10 mV/°C (proportional to their temperature). U3 is used to measure the ambient, while U4 measures the battery temperature.

Note: U4 must be in contact with the metal case of the battery to accurately measure its temperature. The plastic sleeve around the battery may have to be opened up to allow flush contact. Best results are obtained if the sensor is located **between two batteries** (touching both).

Monitoring more than one battery virtually eliminates the possibility that the sensor happens to be reading a bad (shorted) cell which will not heat up and provide charge termination. In some laptops, multiple sensors are used so that all battery cells are monitored, with charge termination occurring when **any** cell temperature reaches the trip level.

The 78L05 regulator (U2) is used to provide a 5V source to power the LM35 sensors and also acts as a reference point for resistive divider R2 and R3. Resistors R1 and R11 are used to sink current (since the LM35 can not).

CONTROLLING THE FAST-CHARGE CURRENT SOURCE

U5C acts as a comparator which controls the on/off pin of the high-current charging source (U1). When the output of U5C is low, the 3A current source is turned on. When the output of U5C is high, U1 is turned off and LED1 is lit which indicates that the charger has completed the high-current charge phase and is now trickle charging.

Hysteresis is built into U5C (see R13), which effectively “latches” the output of U5C high after it completes the fast-charge portion of the cycle (it stays latched until the input power is cycled on and off). Without hysteresis, the charger would again turn on the 3A charger after the fully-charged battery had cooled during trickle charging.

DETECTING AN END-OF-CHARGE CONDITION

The signals that are sent to U5C are derived from the temperature sensors. They cannot be compared directly, since detection must occur when the signal coming from U4 (the battery sensor) is 100 mV above the signal coming from U3 (the ambient sensor).

In this design, the signal from U3 is DC level shifted up about 0.1V by U5A and its associated components. R2 and R3 set a 0.1V reference point for U5A, whose output voltage is the voltage at the output of U3 added to the 0.1V reference.

With the signal from U3 level shifted by an amount that is equal to 10°C, U5C can be used to compare the level-shifted signal from U3 to the signal from U4. When these two are equal, the temperature sensed by U4 (the battery) will be 10°C above the temperature sensed by U3 (the ambient). This is the point where shutdown of the 3A charger occurs, and trickle charging continues.

3A Battery Charger has Logic-Level Current Controls

This design is a 3A battery charger with logic-level controls, allowing a logic controller to adjust the battery charging current to any one of four rates. The circuit was designed to implement μP -based charging control in a system that operates from Ni-Cd or Ni-MH batteries.

GENERAL DESCRIPTION

The circuit shown in *Figure 1* is a 3A (maximum) battery charger that uses a 52 kHz switching converter to step down the input DC voltage and regulate the charging current flowing into the battery. The switching regulator maintains good efficiency over a wide input voltage range, which allows the use of a cheap, poorly regulated “DC wall adaptor” for the input source.

The key feature of this circuit is that it allows the μP controller inside the PC to select from one of four different charging currents by changing the logic levels at two bits. The various

3A Battery Charger has Logic-Level Current Controls

(Continued)

charge levels are necessary to accommodate both Ni-Cd and Ni-MH type batteries, as they require slightly different charge methods.

Both Ni-Cd and Ni-MH batteries can be charged at the high-current “c” rate up until the end-of-charge limit is reached, but the two batteries must be trickle-charged differently (trickle charging is a continuous, low-current charging rate that keeps the battery “topped off” after the high-current charge cycle has delivered about 95% of the battery’s total charge capacity).

The recommended trickle-charge rate for a Ni-Cd is about $c/10$, but for Ni-MH most manufacturers recommend that the charge rate not exceed $c/40$. If a continuous charge rate greater than $c/40$ is applied to a Ni-MH battery, the internal pressure can build up to the point where the battery will vent hydrogen gas. This is detrimental to the life of the Ni-MH battery and potentially dangerous for the user (hydrogen gas is easily ignited).

The circuit shown in *Figure 2* was designed to charge a 3A-hr Ni-Cd or Ni-MH battery with high efficiency, using logic-level signals to control the charging current. The four selectable charge rates are 3A, 0.75A, 0.3A, and 0.075A which correspond to charge rates of c , $c/4$, $c/10$, and $c/40$ for the 3A-hr battery used in this application.

CIRCUIT OPERATION (REFER TO *Figure 2*)

The unregulated DC input voltage is stepped down using an LM2576 3A buck regulator, providing up to 3A of current to charge the battery.

In order to regulate the amount of charging current flowing into the battery, a current control loop is implemented using op-amp U2. The voltage drop across the sense resistor R8 provides a voltage to U2 that is proportional to the charging current.

Note: The 0.05Ω value for R8 was specified by the customer in this application to minimize the power dissipated in this

resistor. If a higher Ohmic value is used (more resistance), a larger sense voltage is developed and a less precise (cheaper) op-amp can be used at U2, since the input offset voltage would not be as critical (of course, increasing the value of R8 also increases its power dissipation).

When the current-control loop is operating, the voltage at the feedback pin of U1 is held at 1.23V. The battery charging current that corresponds to this voltage is dependent on the overall gain of U2 and the attenuators made up of Q1, Q2 and the resistors R10, R11, R2 and R3.

Turning Q1 on (by putting a “1” on logic input “A”) provides an increase of 4:1 in load current. The load current is higher with Q1 on because R2 and R3 divide down the output of U2 by 4:1, requiring U2 to output a higher voltage to get the 1.23V on the feedback line of U1. Higher voltage at the output of U2 means that more charging current is flowing through R8 (also the battery).

The operation of Q2 is similar to Q1: when Q2 is turned on by putting a logic “1” on input “B”, the load current is increased by a factor of 10:1. This is because when Q2 is on, the sense voltage coming from R8 is divided down by R10 and R11, requiring ten times as much signal voltage across R8 to get the same voltage at the non-inverting input of U2.

Although both attenuating dividers could have been placed on the input side of U2, putting the 4:1 divider at the output improves the accuracy and noise immunity of the amplifier U2 (because the voltage applied to the input of U2 is larger, this reduces the input-offset voltage error and switching noise degradation).

R5, R6, and D2 are included to provide a voltage-control loop in the case where the battery is disconnected. These components prevent the voltage at the cathode side of D3 from rising above about 8V when there is no path for the charging current to return (and the current control loop would not be operational).

Capacitor C2 is included to filter some of the 52 kHz noise present on the control line coming from U2. Adding this component improved the accuracy of the measured charging current on the breadboard (compared to the predicted design values).

3A Battery Charger has Logic-Level Current Controls (Continued)

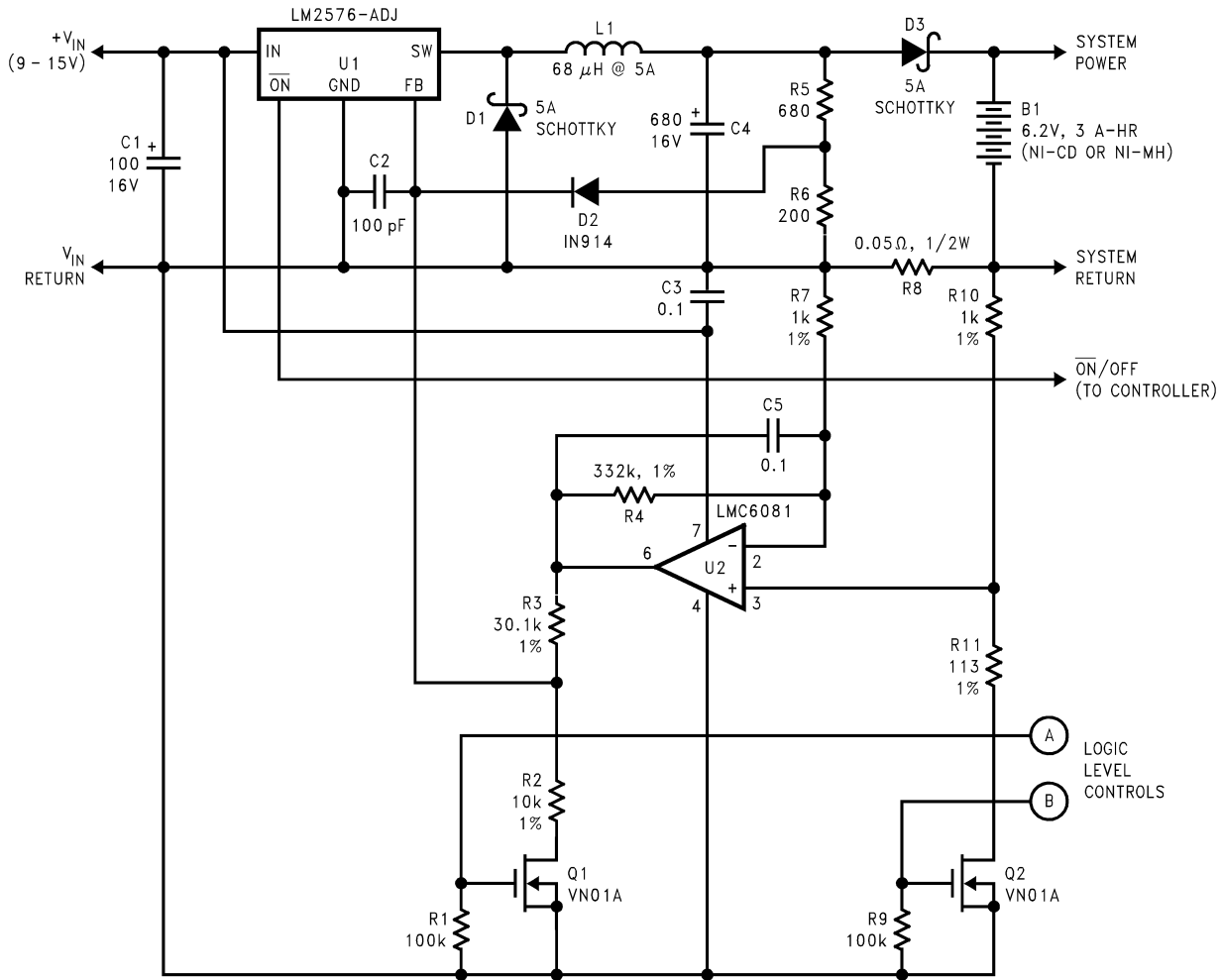

Notes (Unless Otherwise Specified):

Note 1: All resistors are in Ω , 5% tolerance, 1/4W

Note 2: All capacitors are in μF

Note 3: Q1 and Q2 are made by SUPERTEX

Note 4: For 3A current, U1 requires small heatsink ($R_{\text{TH}} \leq 15^\circ\text{C/W}$)

01205402

BENCH TEST DATA

Logic Input "A"	Logic Input "B"	Nominal Battery Charging Current (A)	Measured Battery Charging Current (A) with $V_{\text{IN}} = 10\text{V}$	Power Conversion Efficiency (%) with $V_{\text{IN}} = 10\text{V}$
1	1	3.0 (C RATE)	3.06	77
0	1	0.75 (C/4 RATE)	0.78	79
1	0	0.30 (C/10 RATE)	0.30	
0	0	0.075 (C/40 RATE)	0.077	

FIGURE 2. 3A Battery Charger With Logic-Level Current Controls

Notes

LIFE SUPPORT POLICY

NATIONAL'S PRODUCTS ARE NOT AUTHORIZED FOR USE AS CRITICAL COMPONENTS IN LIFE SUPPORT DEVICES OR SYSTEMS WITHOUT THE EXPRESS WRITTEN APPROVAL OF THE PRESIDENT AND GENERAL COUNSEL OF NATIONAL SEMICONDUCTOR CORPORATION. As used herein:

1. Life support devices or systems are devices or systems which, (a) are intended for surgical implant into the body, or (b) support or sustain life, and whose failure to perform when properly used in accordance with instructions for use provided in the labeling, can be reasonably expected to result in a significant injury to the user.
2. A critical component is any component of a life support device or system whose failure to perform can be reasonably expected to cause the failure of the life support device or system, or to affect its safety or effectiveness.



National Semiconductor Corporation
Americas
Email: support@nsc.com

www.national.com

National Semiconductor Europe

Fax: +49 (0) 180-530 85 86
Email: europe.support@nsc.com
Deutsch Tel: +49 (0) 69 9508 6208
English Tel: +44 (0) 870 24 0 2171
Français Tel: +33 (0) 1 41 91 8790

National Semiconductor Asia Pacific Customer Response Group

Tel: 65-2544466
Fax: 65-2504466
Email: ap.support@nsc.com

National Semiconductor Japan Ltd.

Tel: 81-3-5639-7560
Fax: 81-3-5639-7507