

Battery Chargers and Zappers

The sources of the following circuits are contained in the Sources section, which begins on page 125. The figure number in the box of each circuit correlates to the source entry in the Sources section.

Lead-Acid Battery Charger
 12-V Battery Charger
 200-mA-hour 12-V NiCad Battery Charger
 NiCad Charger with Current and Voltage Limiting
 14-V 4-A Battery Charger/Power Supply
 Fast Charger for NiCad Batteries
 Current-Limited 6-V Charger
 NiCad Charger
 Simple NiCad Battery Zapper
 Battery Charger
 Automatic Shutoff Battery Charger
 Battery-Charging Regulator
 12-V Battery-Charger Control (20 rms Max.)
 Battery Charger
 Universal Battery Charger
 Lead-Acid Low-Battery Detector

Universal Battery Charger
 UJT Battery Charger
 Automotive Charger for NiCad Battery Packs
 Constant-Voltage Current-Limited Charger
 Versatile Battery Charger
 Gel-Cell Charger
 NiCad Battery Zapper
 PUT Battery Charger
 Thermally Controlled NiCad Charger
 NiCad Battery Zapper II
 Portable NiCad Battery Charger
 Lithium Battery Charger
 Rapid Battery Charger for Icom IC-2A
 Battery Charger Operates on Single Solar Cell
 Wind-Powered Battery Charger

LEAD-ACID BATTERY CHARGER

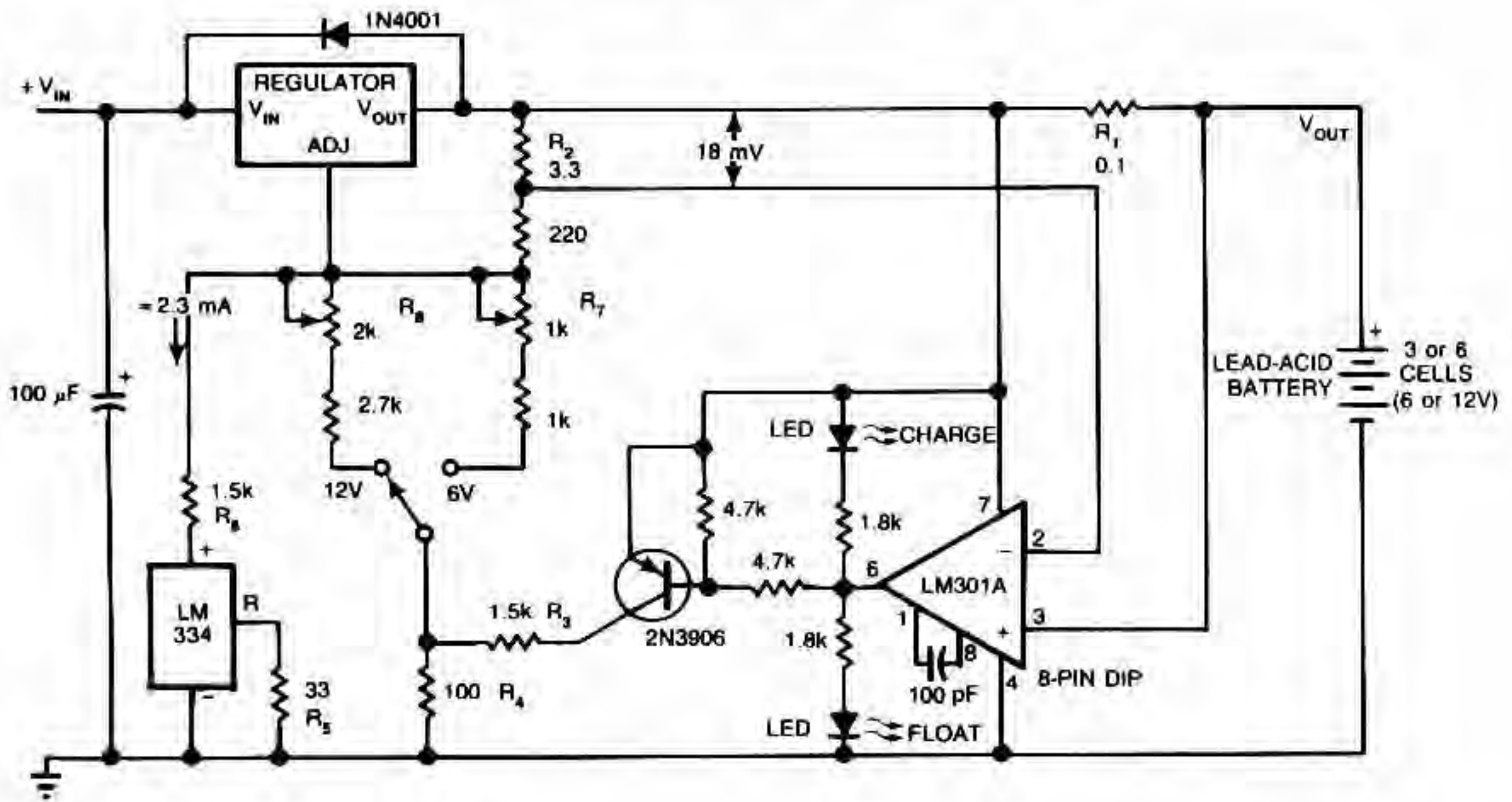

EDN

Fig. 1-1

This circuit furnishes an initial voltage of 2.5 V per cell at 25°C to rapidly charge a battery. The charging current decreases as the battery charges, and when the current drops to 180 mA, the charging circuit reduces the output voltage to 2.35 V per cell, leaving the battery in a fully charged state. This lower voltage prevents the battery from overcharging, which would shorten its life.

The LM301A compares the voltage drop across R1 with an 18 mV reference set by R2. The comparator's output controls the voltage regulator, forcing it to produce the lower float voltage when the battery-charging current, passing through R1, drops below 180 mA. The 150 mV difference between the charge and float voltages is set by the ratio of R3 to R4. The LEDs show the state of the circuit.

Temperature compensation helps prevent overcharging, particularly when a battery undergoes wide temperature changes while being charged. The LM334 temperature sensor should be placed near or on the battery to decrease the charging voltage by 4 mV/°C for each cell. Because batteries need more temperature compensation at lower temperatures, change R5 to 30 Ω for a tc of -5 mV/°C per cell if application will see temperatures below -20°C.

The charger's input voltage must be filtered dc that is at least 3 V higher than the maximum required output voltage: approximately 2.5 V per cell. Choose a regulator for the maximum current needed: LM371 for 2 A, LM350 for 4 A, or LM338 for 8 A. At 25°C and with no output load, adjust R7 for a V_{OUT} of 7.05 V, and adjust R8 for a V_{OUT} of 14.1 V.

12-V BATTERY CHARGER

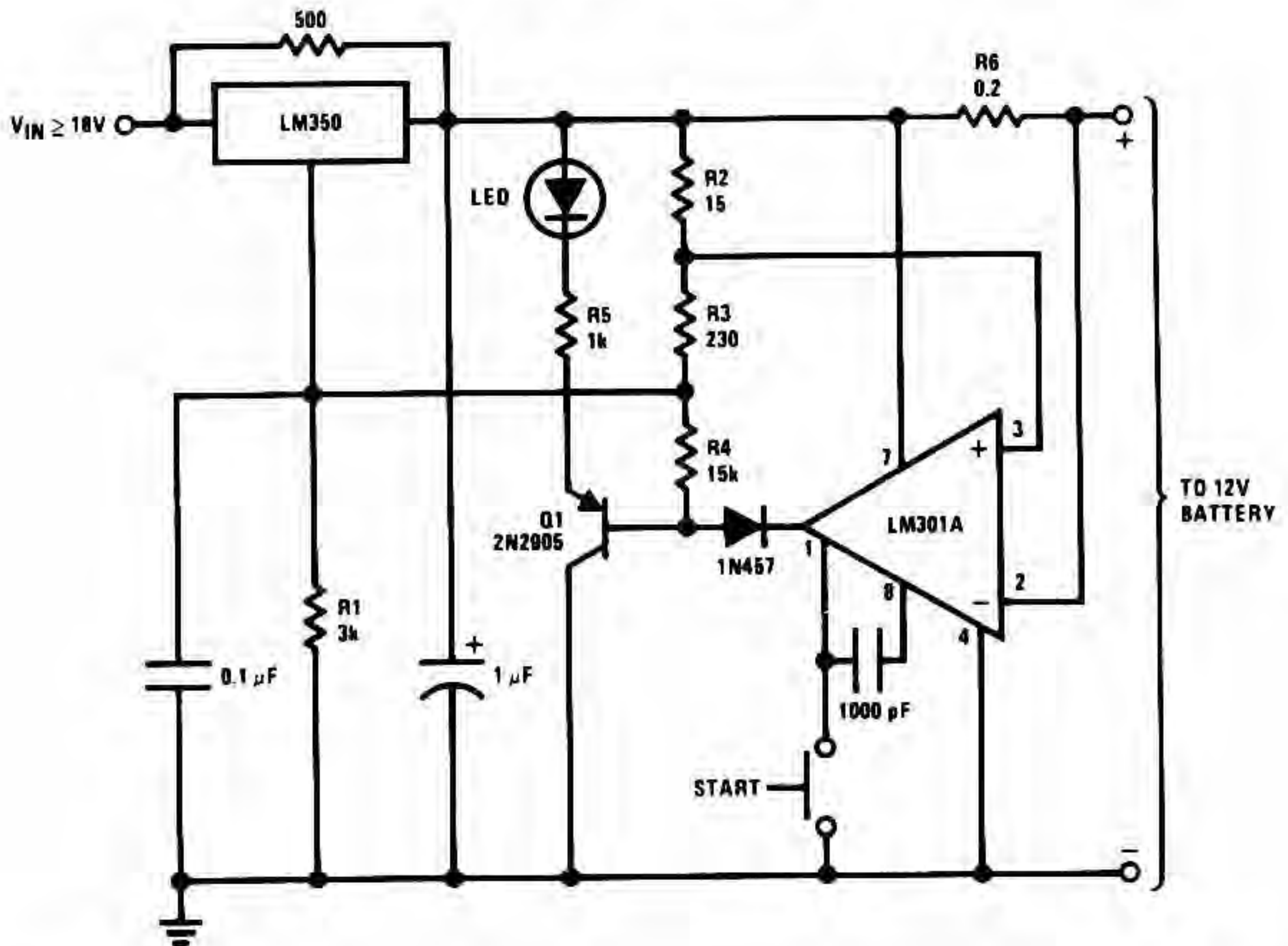

NATIONAL SEMICONDUCTOR

Fig. 1-2

This circuit is a high-performance charger for gelled-electrolyte lead-acid batteries. This charger quickly recharges the battery and shuts off at full charge. Initially, charging current is limited to 2 A. As the battery voltage rises, current to the battery decreases, and when the current has decreased to 150 mA, the charger switches to a lower float voltage, which prevents overcharge. When the start switch is pushed, the output of the charger goes to 14.5 V. As the battery approaches full charge, the charging current decreases and the output voltage is reduced from 14.5 V to about 12.5 V, terminating the charging. Transistor Q1 then lights the LED as a visual indication of full charge.

200-mA/HOUR, 12-V NICAD BATTERY CHARGER

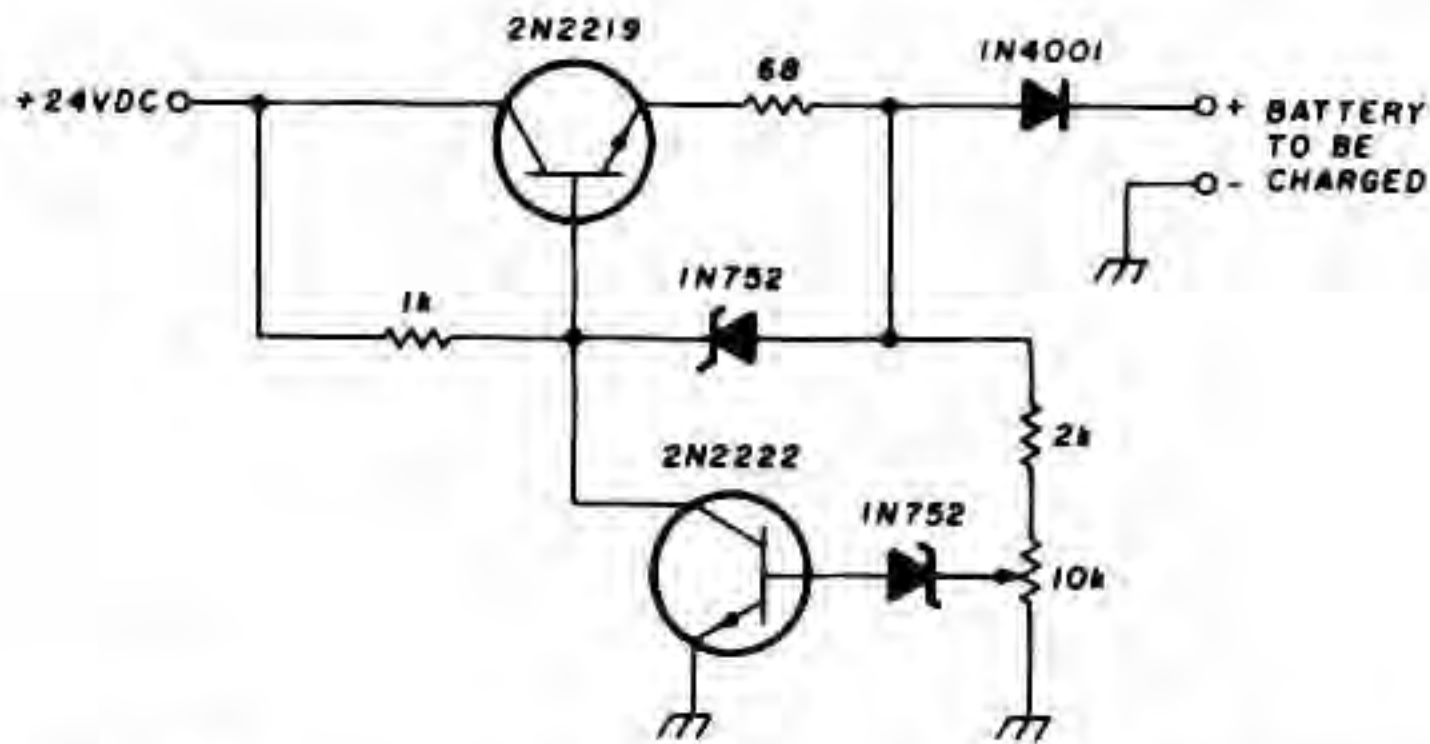

HAM RADIO

Fig. 1-3

This circuit charges the battery at 75 mA until the battery is charged, then it reduces the current to a trickle rate. It will completely recharge a dead battery in four hours and the battery can be left in the charger indefinitely. To set the shut-off point, connect a 270- Ω , 2-W resistor across the charge terminals and adjust the pot for 15.5 V across the resistor.

NICAD CHARGER WITH CURRENT AND VOLTAGE LIMITING

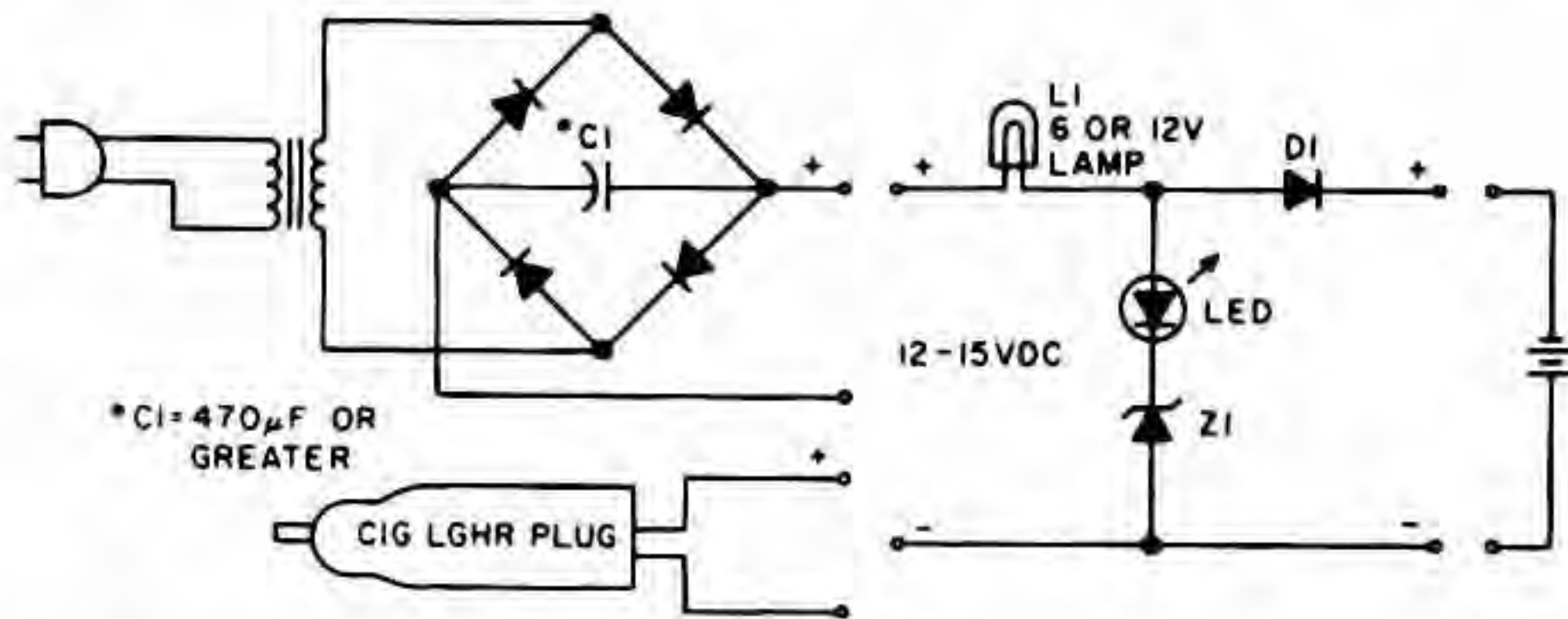

73 AMATEUR RADIO

Fig. 1-4

Lamp L1 will glow brightly and the LED will be out when the battery is low and being charged, but the LED will be bright and the light dim when the battery is almost ready. L1 should be a bulb that is rated for the current you want (usually the battery capacity divided by 10). Diode D1 should be at least 1 A, and Z1 is a 1-W zener diode with a voltage determined by the full-charge battery voltage minus 1.5 V. After the battery is fully charged, the circuit will float it at about battery capacity divided by 100 mA.

14-V 4-A BATTERY CHARGER/POWER SUPPLY

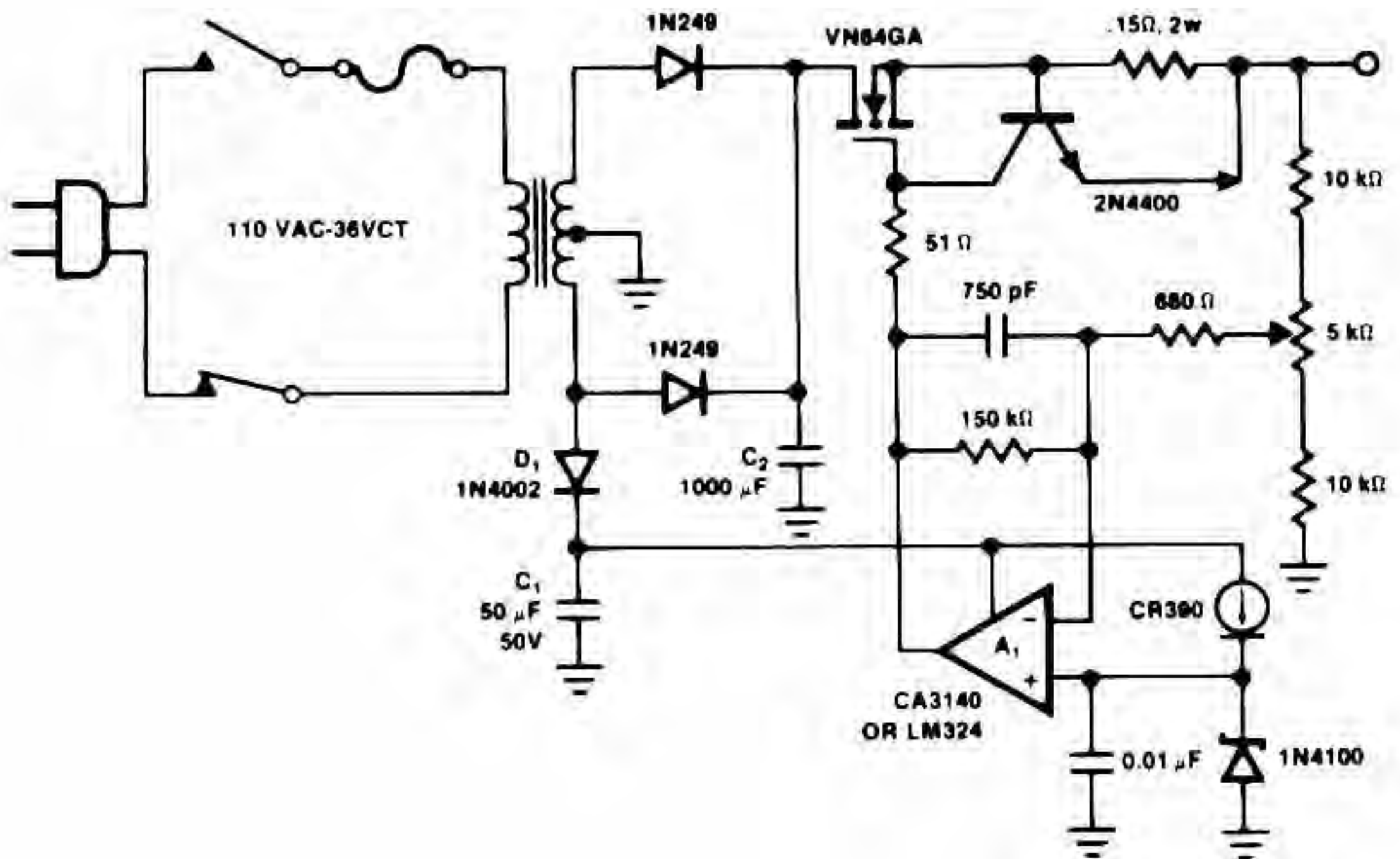

SILICONIX

Fig. 1-5

Operational amplifier A1 directly drives the VN64GA with the error signal to control the output voltage. Peak rectifier D1, C1 supplies error amplifier A1 and the reference zener. This extra drive voltage must exceed its source voltage by several volts for the VN64GA to pass full load current. The output voltage is pulsating dc, which is quite satisfactory for battery charging. To convert the system to a regulated dc supply, capacitor C2 is increased and another electrolytic capacitor is added across the load. The response time is very fast, determined by the op amp. The 2N4400 current-limiter circuit prevents the output current from exceeding 4.5 A. However, maintaining a shorted condition for more than one second will cause the VN64GA to exceed its temperature ratings. A generous heatsink, on the order of $1^{\circ}\text{C}/\text{W}$, must be used.

FAST CHARGER FOR NICAD BATTERIES

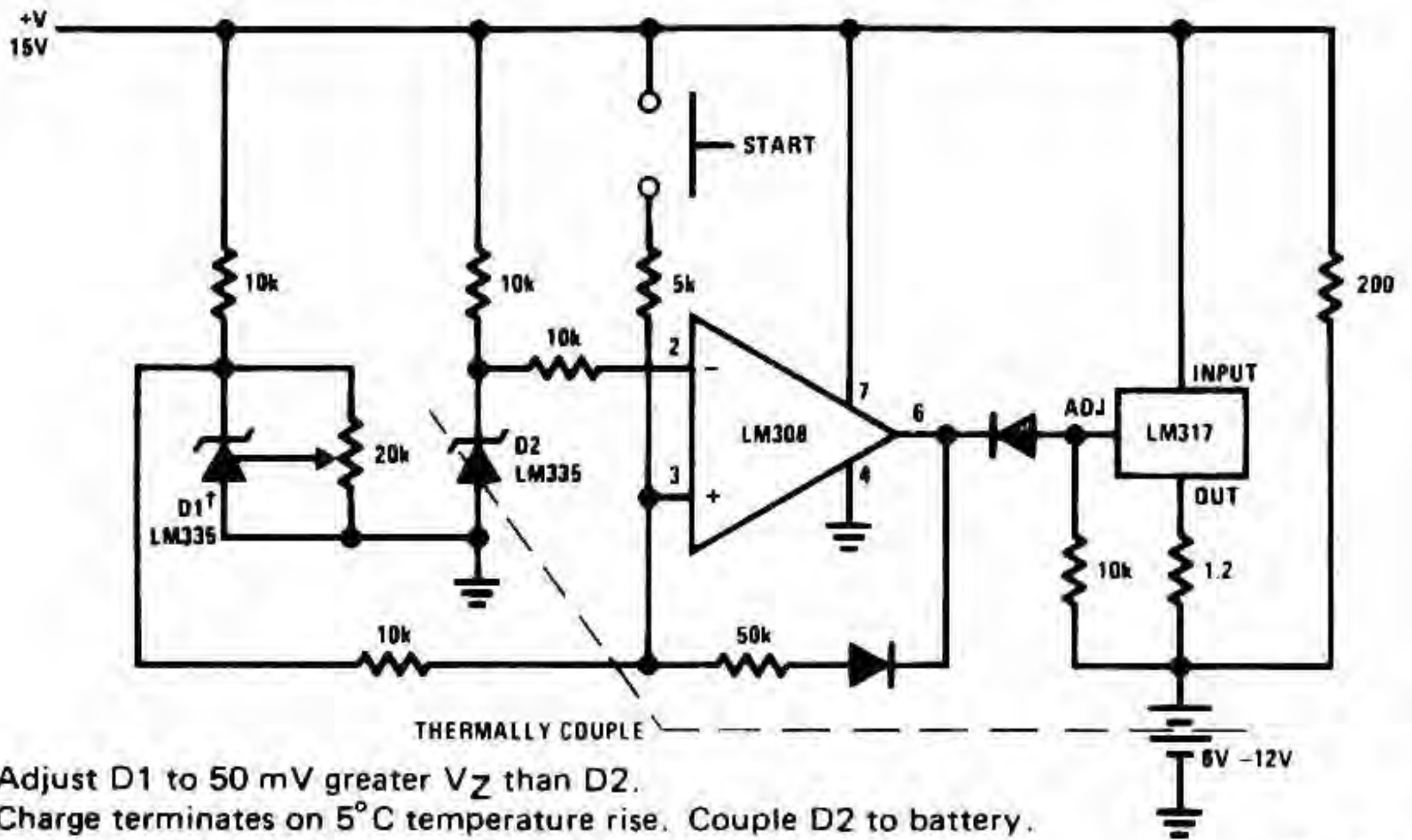

NATIONAL SEMICONDUCTOR

Fig. 1-6

CURRENT-LIMITED 6-V CHARGER

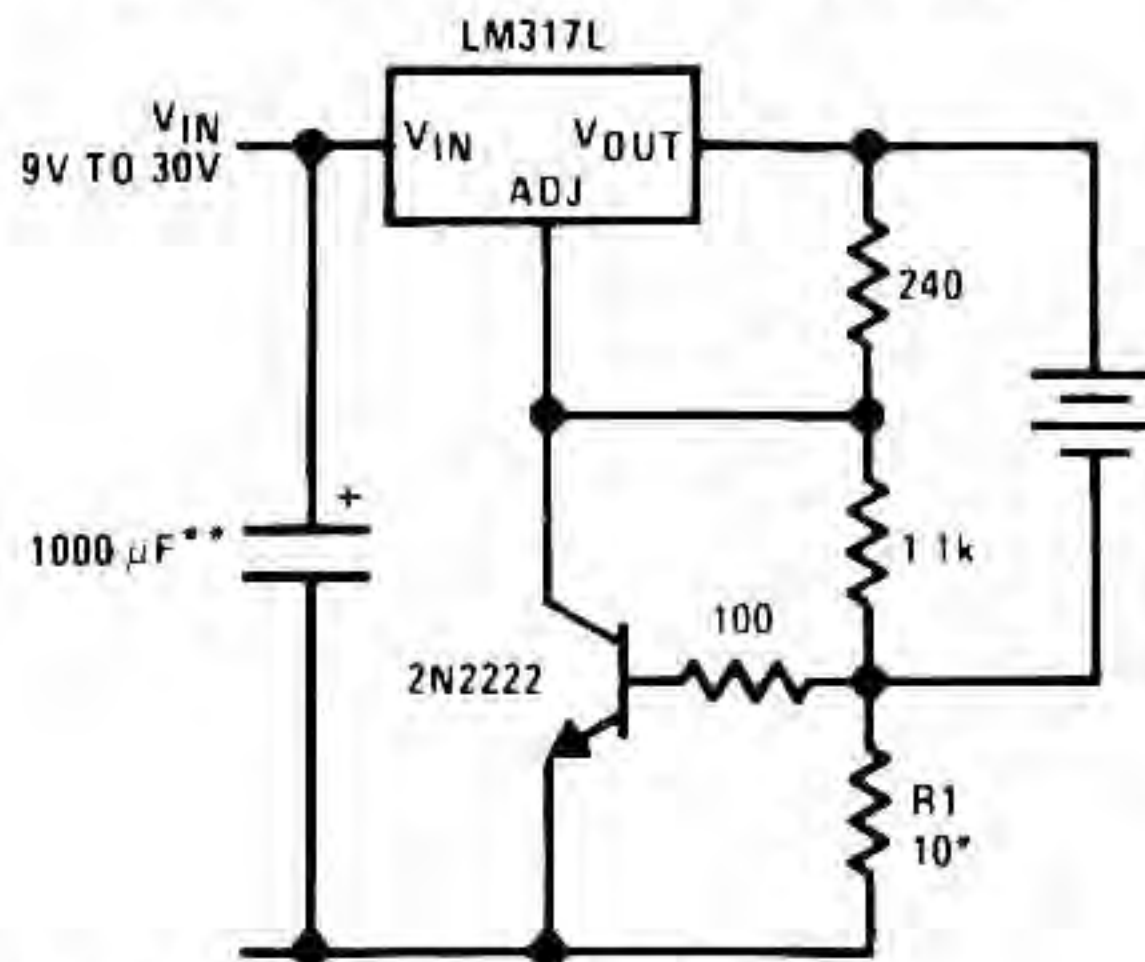

- * Sets peak current, $I_{PEAK} = 0.6V/R1$
- ** 1000 μF is recommended to filter out any input transients

NATIONAL SEMICONDUCTOR

Fig. 1-7

NICAD CHARGER

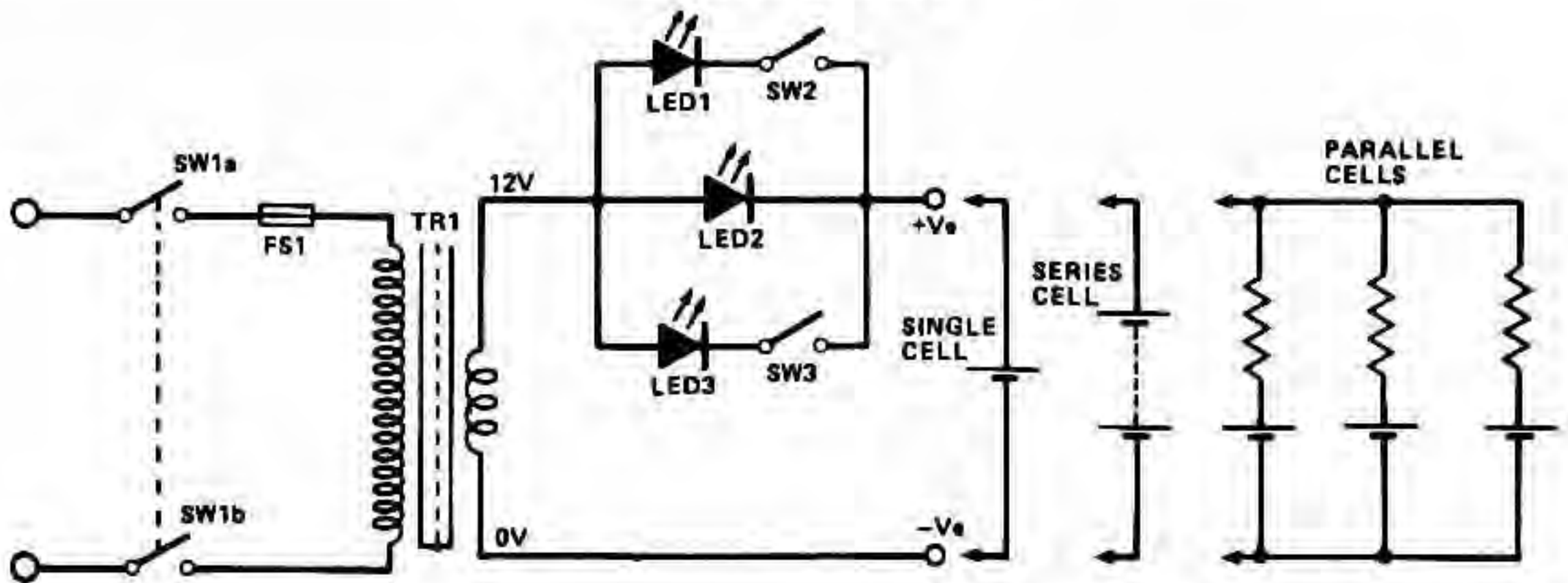

ELECTRONICS TODAY INTERNATIONAL

Fig. 1-8

This circuit uses constant current LEDs to adjust charging current. It uses LEDs that pass a constant current of about 15 mA for an applied voltage range of 2 to 18 V. They can be paralleled to give any multiple of 15 mA and they light up when current is flowing. The circuit will charge a single cell at 15, 30, or 45 mA, or cells in series up to the rated supply voltage limit (about 14 V).

SIMPLE NICAD BATTERY ZAPPER

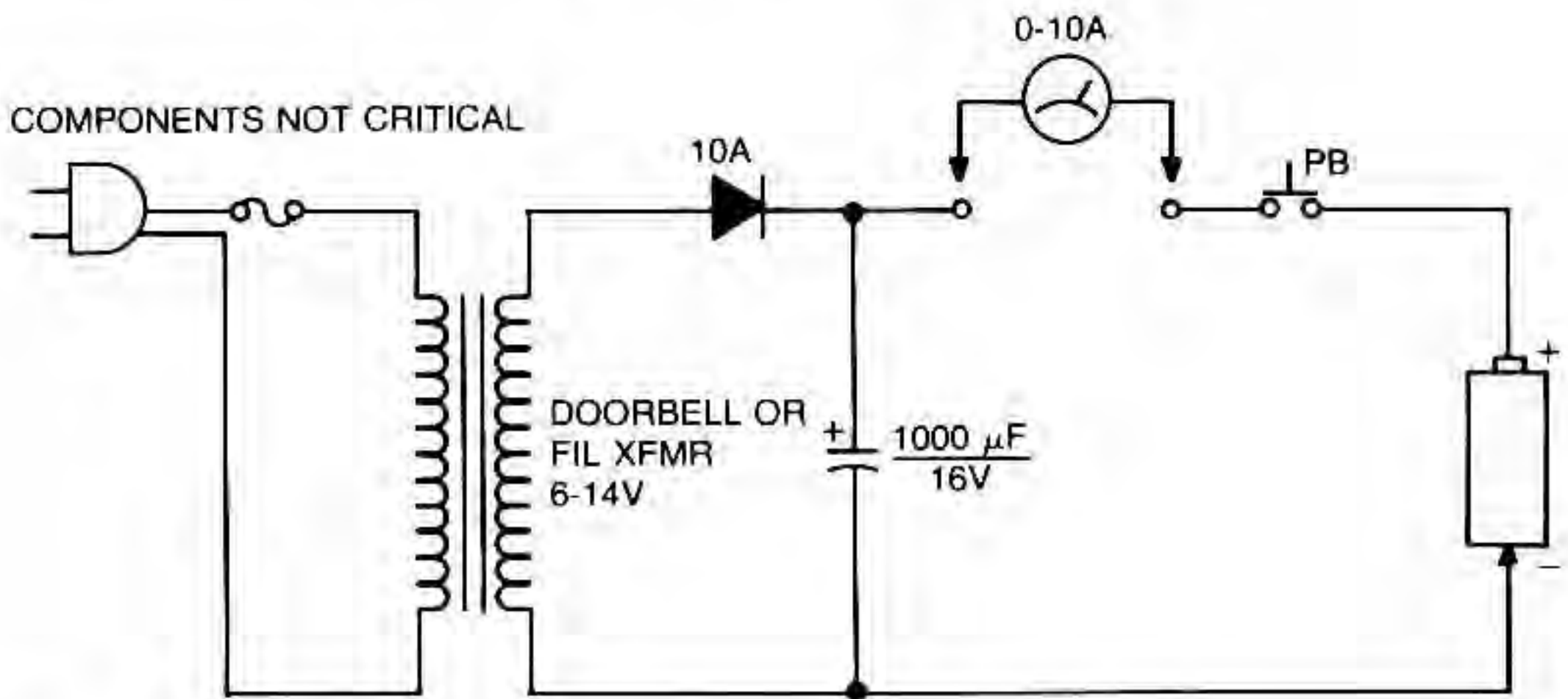

73 AMATEUR RADIO

Fig. 1-9

This circuit is used to clear internal shorts in nickel-cadmium batteries. To operate, connect a NiCad battery to the output and press the pushbutton for three seconds.

BATTERY CHARGER

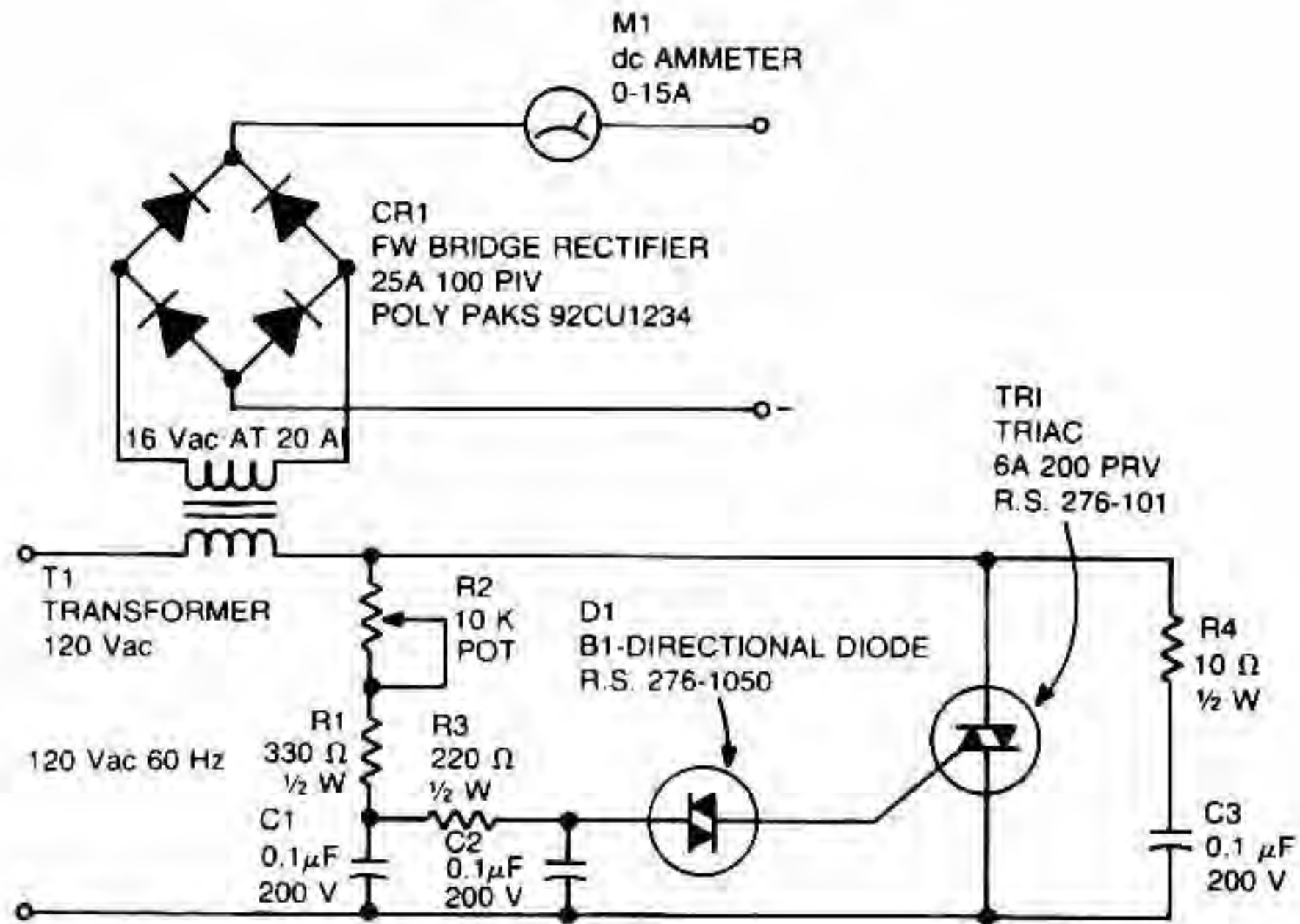

73 AMATEUR RADIO

Fig. 1-10

A diac is used in the gate circuit to provide a threshold level for firing the triac. C3 and R4 provide a transient suppression network. R1, R2, R3, C1, and C2 provide a phase-shift network for the signal being applied to the gate. R1 is selected to limit the maximum charging current at full rotation of R2.

AUTOMATIC SHUTOFF BATTERY CHARGER

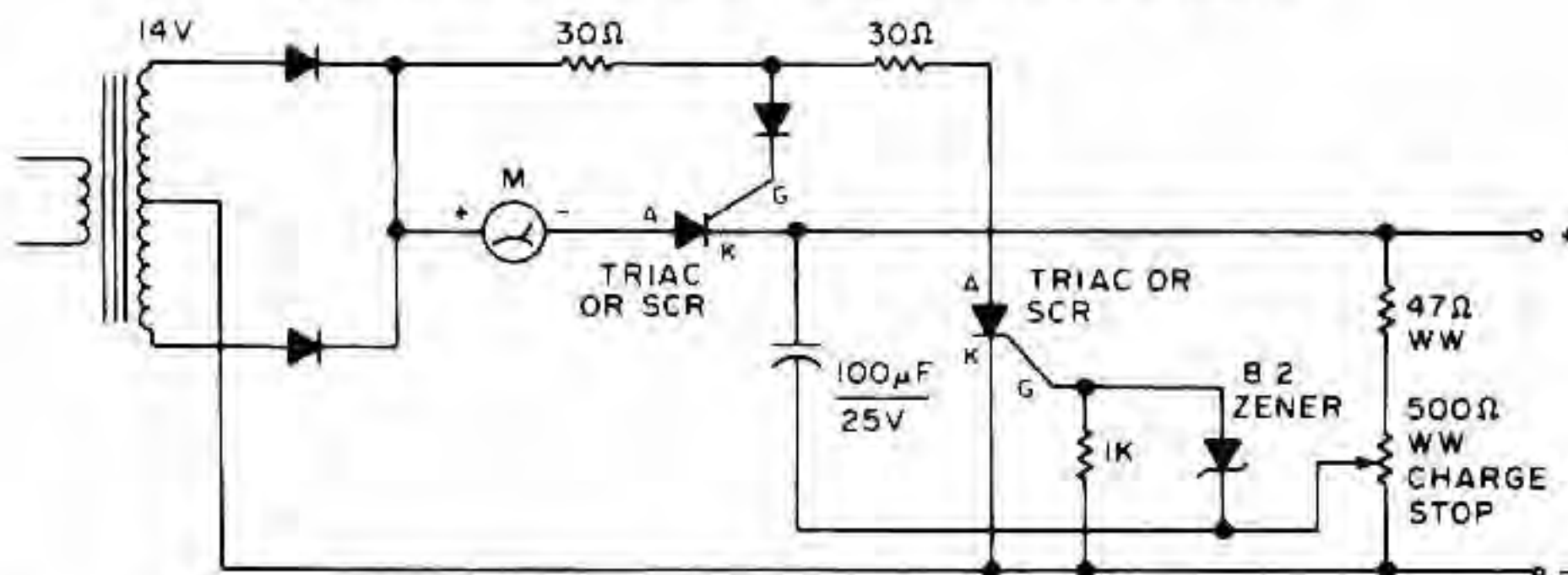

73 AMATEUR RADIO

Fig. 1-11

Adjust this circuit by setting the 500-Ω resistor while it is attached to a fully charged battery.

BATTERY-CHARGING REGULATOR

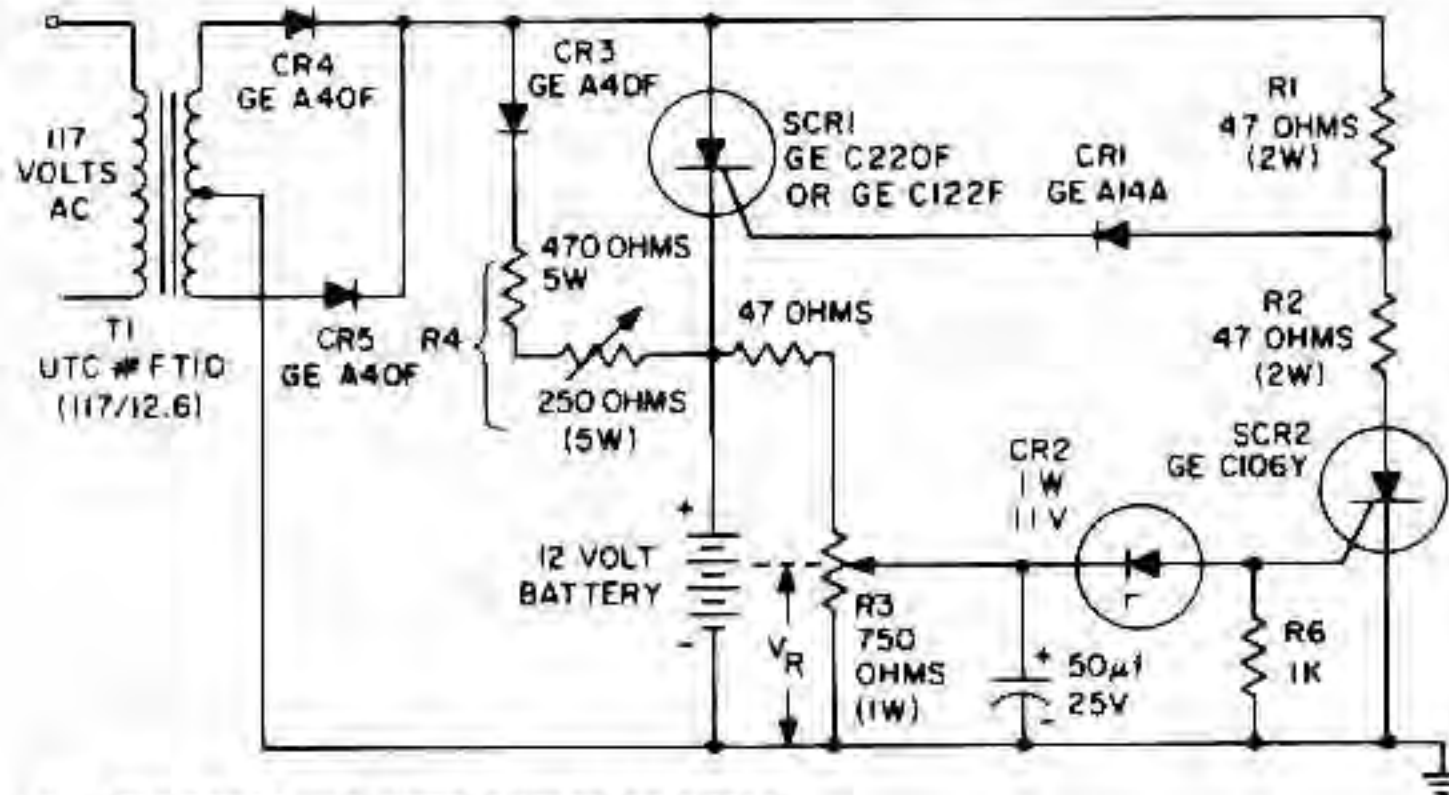

ALL RESISTORS 1/2 WATT EXCEPT AS NOTED

GE

Fig. 1-12

The circuit is capable of charging a 12-V battery at up to a six ampere rate. Other voltages and currents, from 6 to 600 V and up to 300 A, can be accommodated by suitable component selection. When the battery voltage reaches its fully charged level, the charging SCR shuts off, and a trickle charge, as determined by the value of R4, continues to flow.

12-V BATTERY-CHARGER CONTROL (20 A rms MAX.)

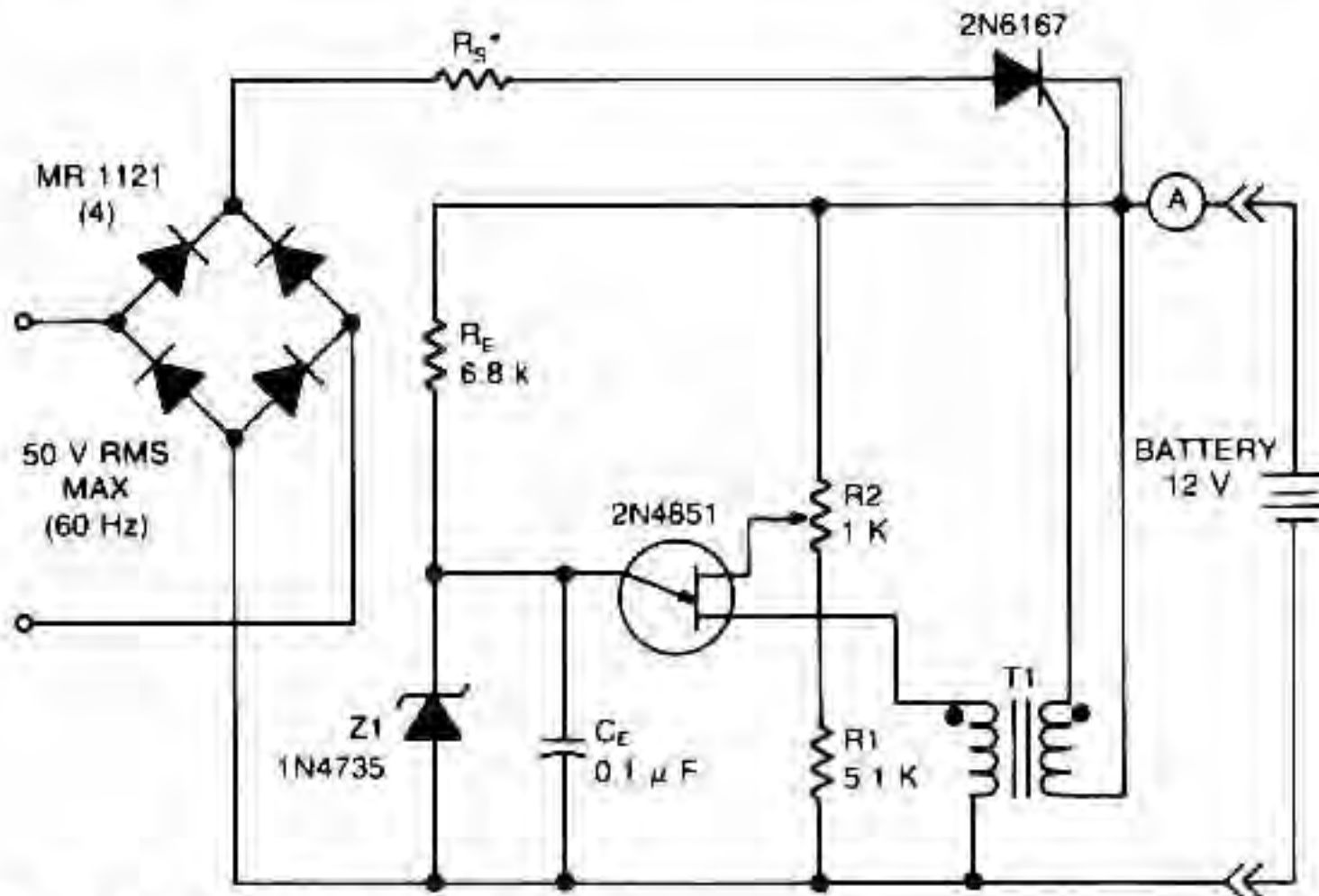

T1 - PRIMARY = 30 TURNS #22
 SECONDARY = 45 TURNS #22
 CORE = FERROXCUBE 203 F 1B1-3C3
 R_S SERIES RESISTANCE TO LIMIT CURRENT THROUGH SCR
 2N6167 IS RATED AT 20 AMPS RMS

MOTOROLA

Fig. 1-13

BATTERY CHARGER

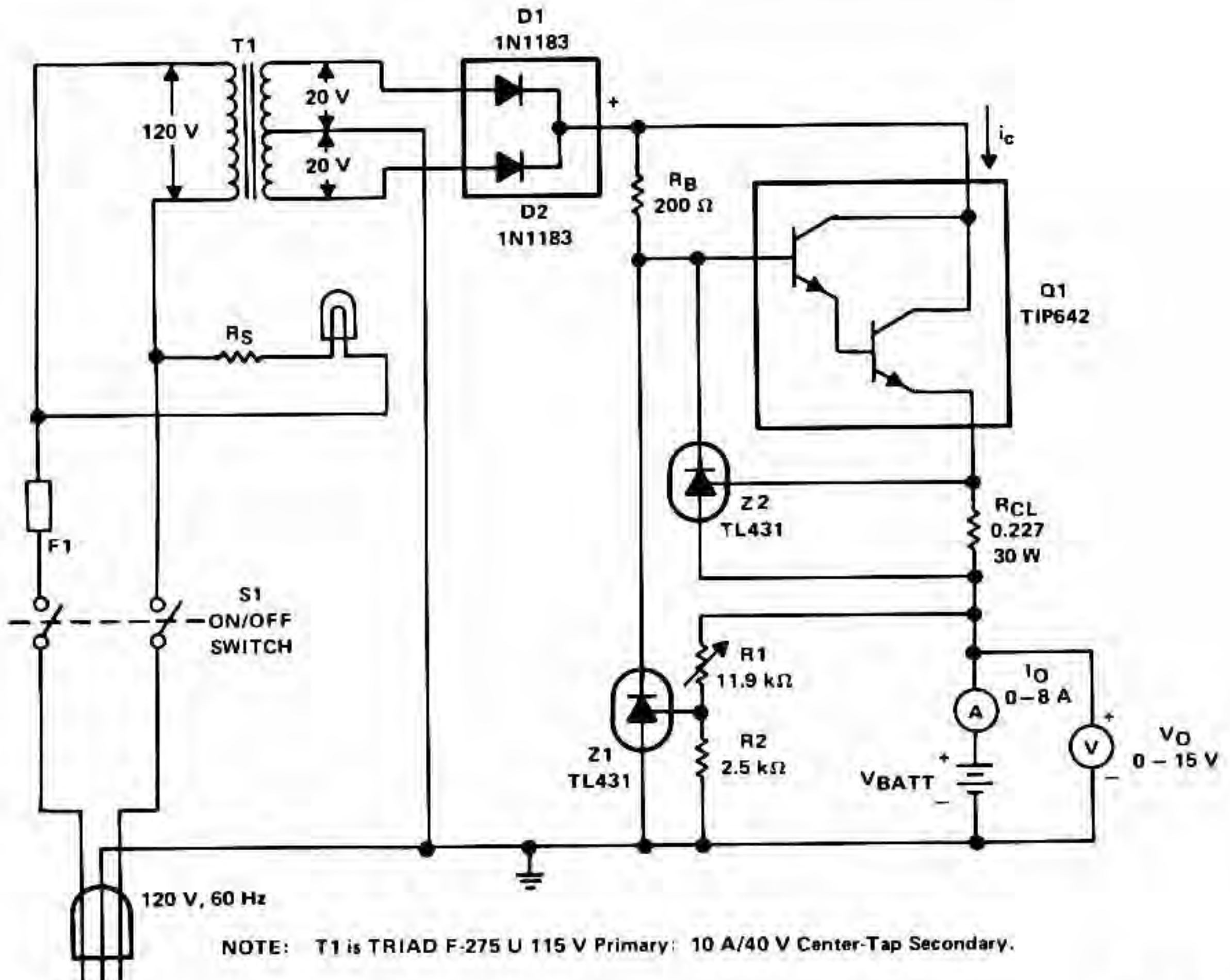

TEXAS INSTRUMENTS

Fig. 1-14

The charger is based on a charging voltage of 2.4 V per cell, in accordance with most manufacturers' recommendations. The circuit pulses the battery under charge with 14.4 V (6 cells \times 2.4 V per cell) at a rate of 120 Hz. The design provides current limiting to protect the charger's internal components while limiting the charging rate to prevent damaging severely discharged lead-acid batteries. The maximum recommended charging current is normally about one-fourth the ampere-hour rating of the battery. For example, the maximum charging current for an average 44 ampere-hour battery is 11 A. If the impedance of the load requires a charging current greater than the 11 A current limit, the circuit will go into current limiting. The amplitude of the charging pulses is controlled to maintain a maximum peak charging current of 11 A (8 A average).

UNIVERSAL BATTERY CHARGER

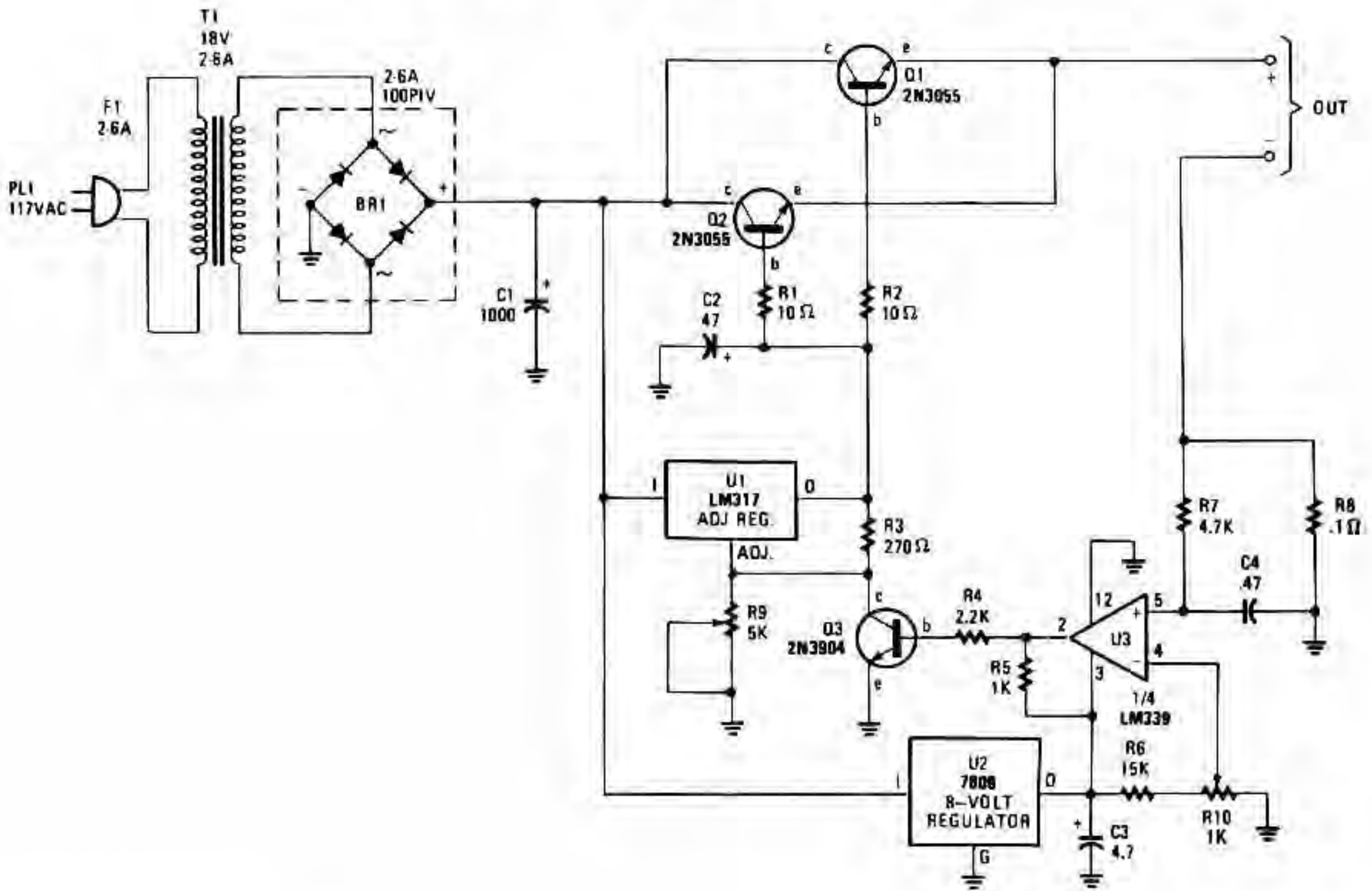

POPULAR ELECTRONICS

Fig. 1-15

The charger's output voltage is adjustable and regulated, and has an adjustable constant-current charging circuit that makes it easy to use with most NiCad batteries. The charger can charge a single cell or a number of series-connected cells up to a maximum of 18 V.

Power transistors Q1 and Q2 are connected as series regulators to control the battery charger's output voltage and charge-current rate. An LM317 adjustable voltage regulator supplies the drive signal to the bases of power transistors Q1 and Q2. Potentiometer R9 sets the output-voltage level. A current-sampling resistor, R8 (a 0.1-Ω, 5-W unit), is connected between the negative output lead and circuit ground. For each amp of charging current that flows through R8, a 100 mV output is developed across it. The voltage developed across R8 is fed to one input of comparator U3. The other input of the comparator is connected to variable resistor R10.

As the charging voltage across the battery begins to drop, the current through R8 decreases. Then the voltage feeding pin 5 of U3 decreases, and the comparator output follows, turning Q3 back off, which completes the signal's circular path to regulate the battery's charging current.

The charging current can be set by adjusting R10 for the desired current. The circuit's output voltage is set by R9.

LEAD-ACID LOW-BATTERY DETECTOR

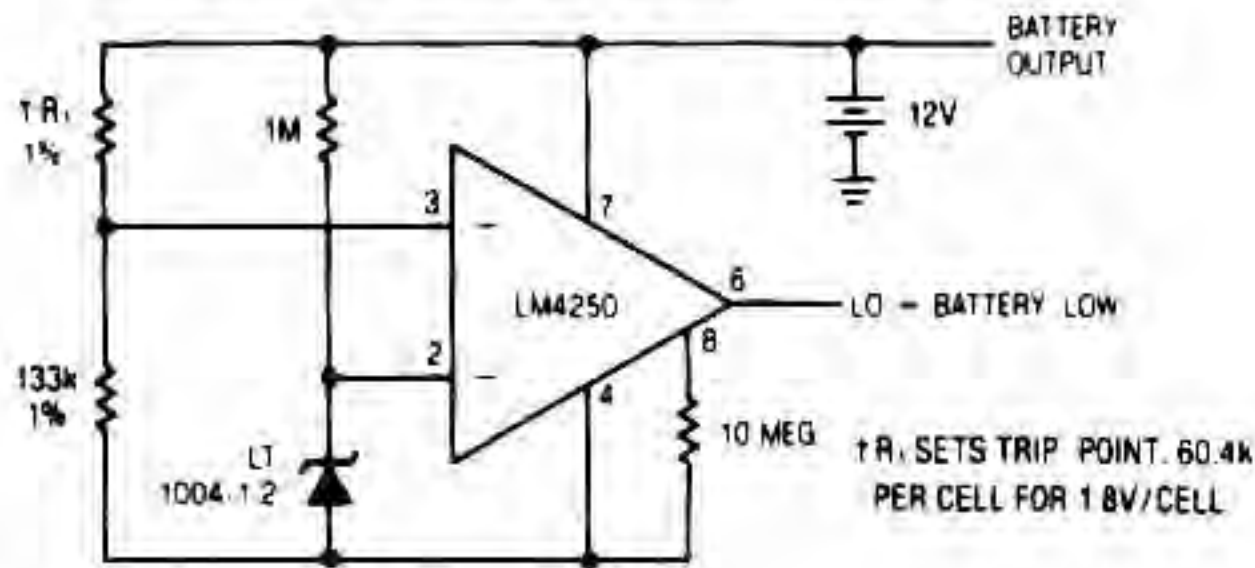

LINEAR TECHNOLOGY

Fig. 1-16

UNIVERSAL BATTERY CHARGER

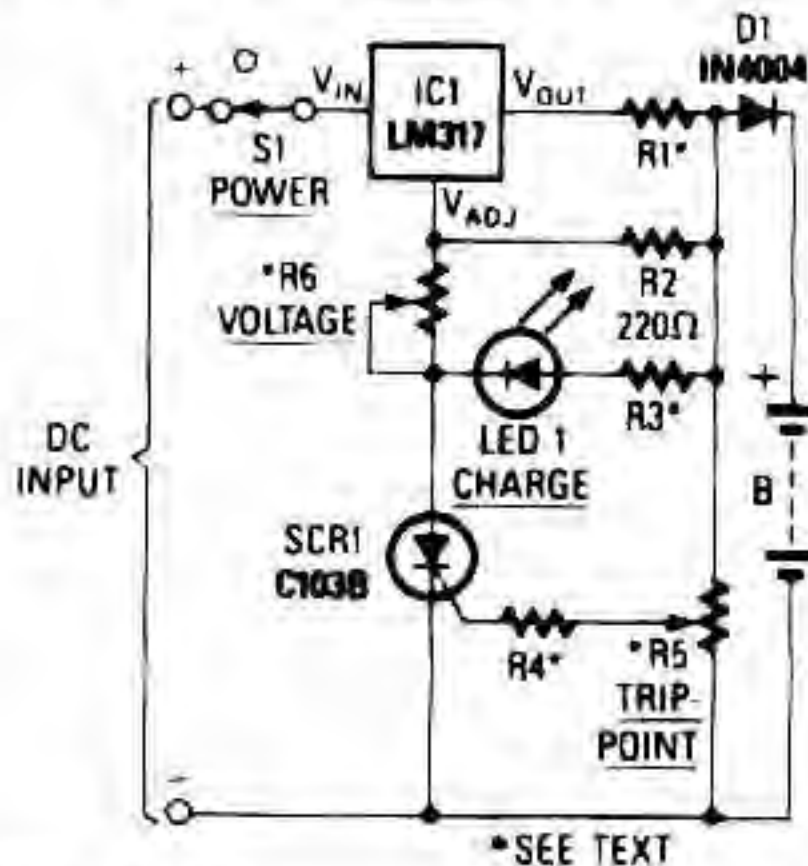

RADIO-ELECTRONICS

Fig. 1-17

When power is applied to the circuit, SCR1 is off, so there is no bias-current path to ground; thus, LM317 acts as a current regulator. The LM317 is connected to the battery through steering diode D1, limiting resistor R1, and bias resistor R2. The steering diode prevents the battery from discharging through the LED and the SCR when power is removed from the circuit. As the battery charges, the voltage across trip-point potentiometer R5 rises, and at some point, turns on the SCR. Then, current from the regulator can flow to ground, so the regulator now functions in the voltage mode. When the SCR turns on, it also provides LED1 with a path to ground through R3. So, when LED1 is on, the circuit is in the voltage-regulating mode; when LED1 is off, the circuit is in the current-regulating mode.

UJT BATTERY CHARGER

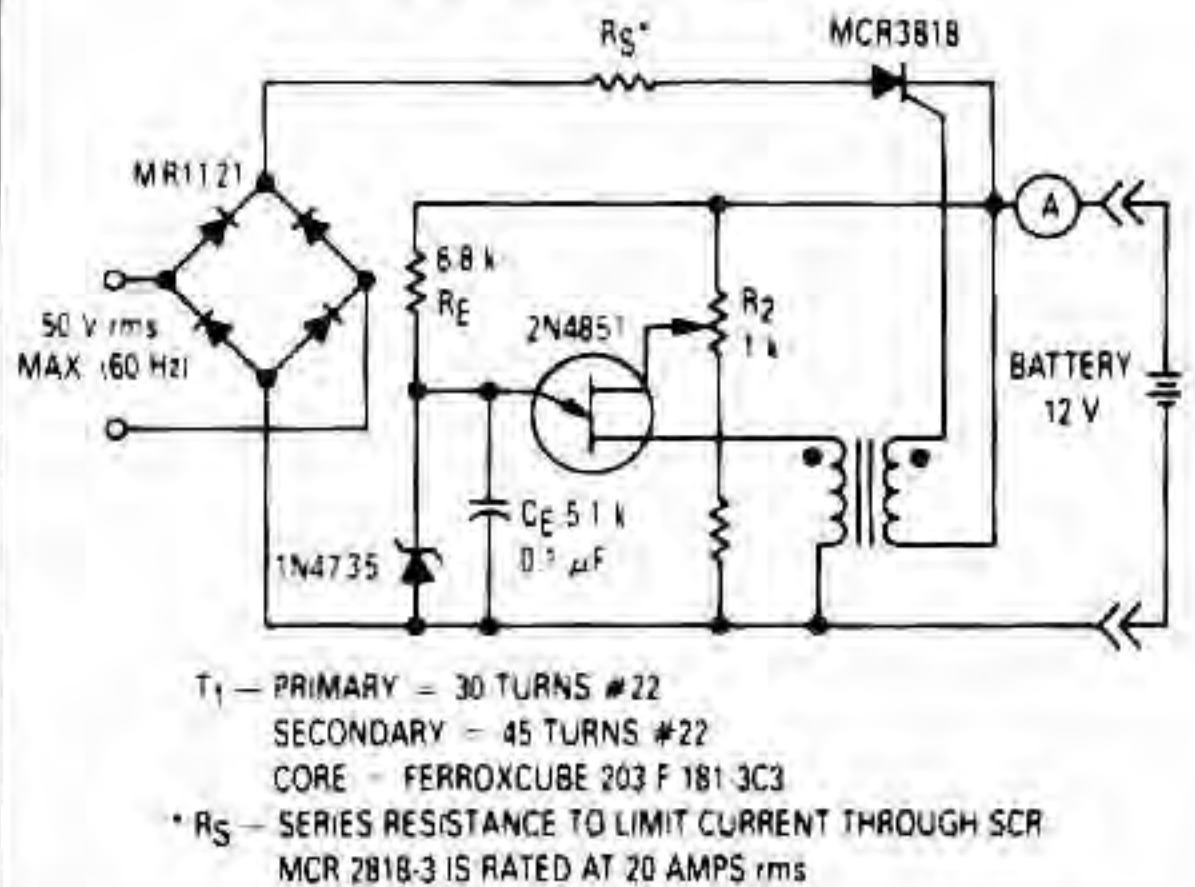

MOTOROLA

Fig. 1-18

This circuit will not work unless the battery to be charged is connected with proper polarity. The battery voltage controls the charger and when the battery is fully charged, the charger will not supply current to the battery. The battery charging current is obtained through the SCR when it is triggered into the conducting state by the UJT relaxation oscillator. The oscillator is only activated when the battery voltage is low. $V_{B_2B_1}$ of the UJT is derived from the voltage of the battery to be charged, and since $V_P = V_D = V_{B_2B_1}$; the higher $V_{B_2B_1}$, the higher V_P . When V_P exceeds the breakdown voltage of the zener diode Z1, the UJT will cease to fire and the SCR will not conduct. This indicates that the battery has attained its desired charge as set by R2.

AUTOMOTIVE CHARGER FOR NICAD BATTERY PACKS

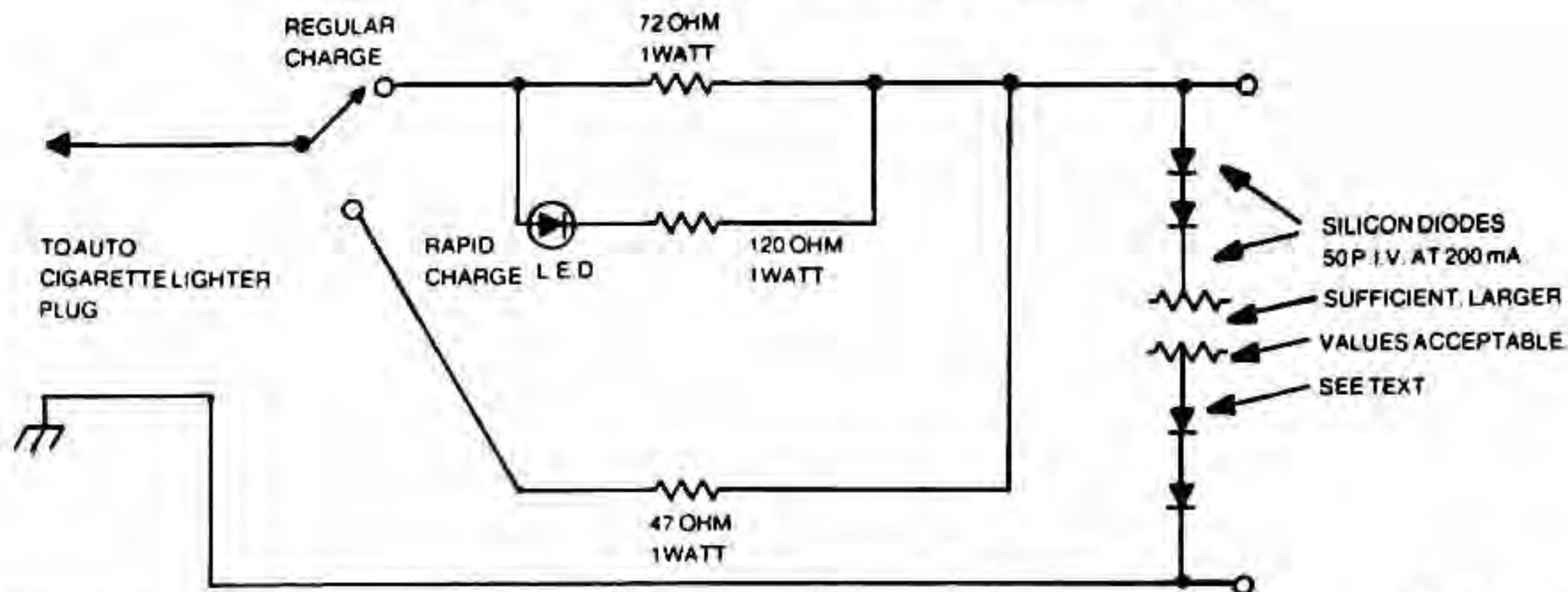

TAB BOOKS

Fig. 1-19

The number of silicon diodes across the output is determined by the voltage of the battery pack. Figure each diode at 0.7 V. For example, a 10.9-V pack would require $10.9/0.7 = 15.57$, or 16 diodes.

CONSTANT-VOLTAGE CURRENT-LIMITED CHARGER

IC LM723C VOLTAGE REGULATOR (FOR 12V dc OUTPUT 0.42A MAX.)

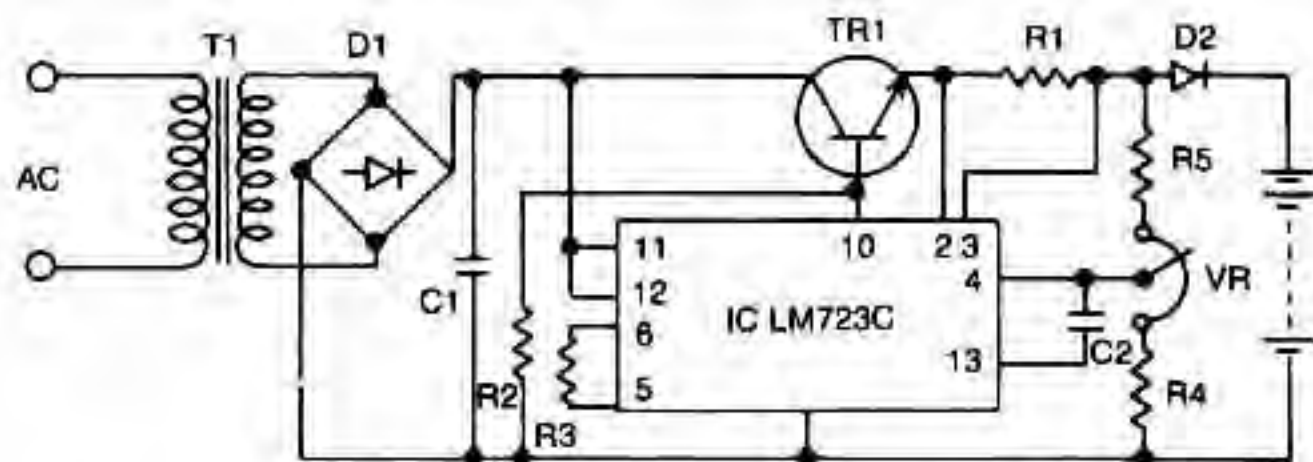

For 12-V sealed lead-acid batteries.

- | | |
|--------|---|
| T1 | Transformer, dc 13V (rms), 1-3A (rms) |
| D1, D2 | 100V 1A Diode |
| C1 | 50V, 470 μ F Electrolytic Condenser |
| TR1 | MJ2840 10A 60V 150W (Motorola) |
| IC | LM723C (National Semiconductor) |
| R1 | 4.7 Ohm 1/2W 3P |
| R2 | 5.1K Ohm 1/4W |
| R3 | 3.9K Ohm 1/4W |
| R4 | 7.5K Ohm 1/4W |
| R5 | 8.2K Ohm 1/4W |
| VR | 2K Ohm |
| C2 | 50V 1000pF |

YUASA BATTERY

Fig. 1-20

VERSATILE BATTERY CHARGER

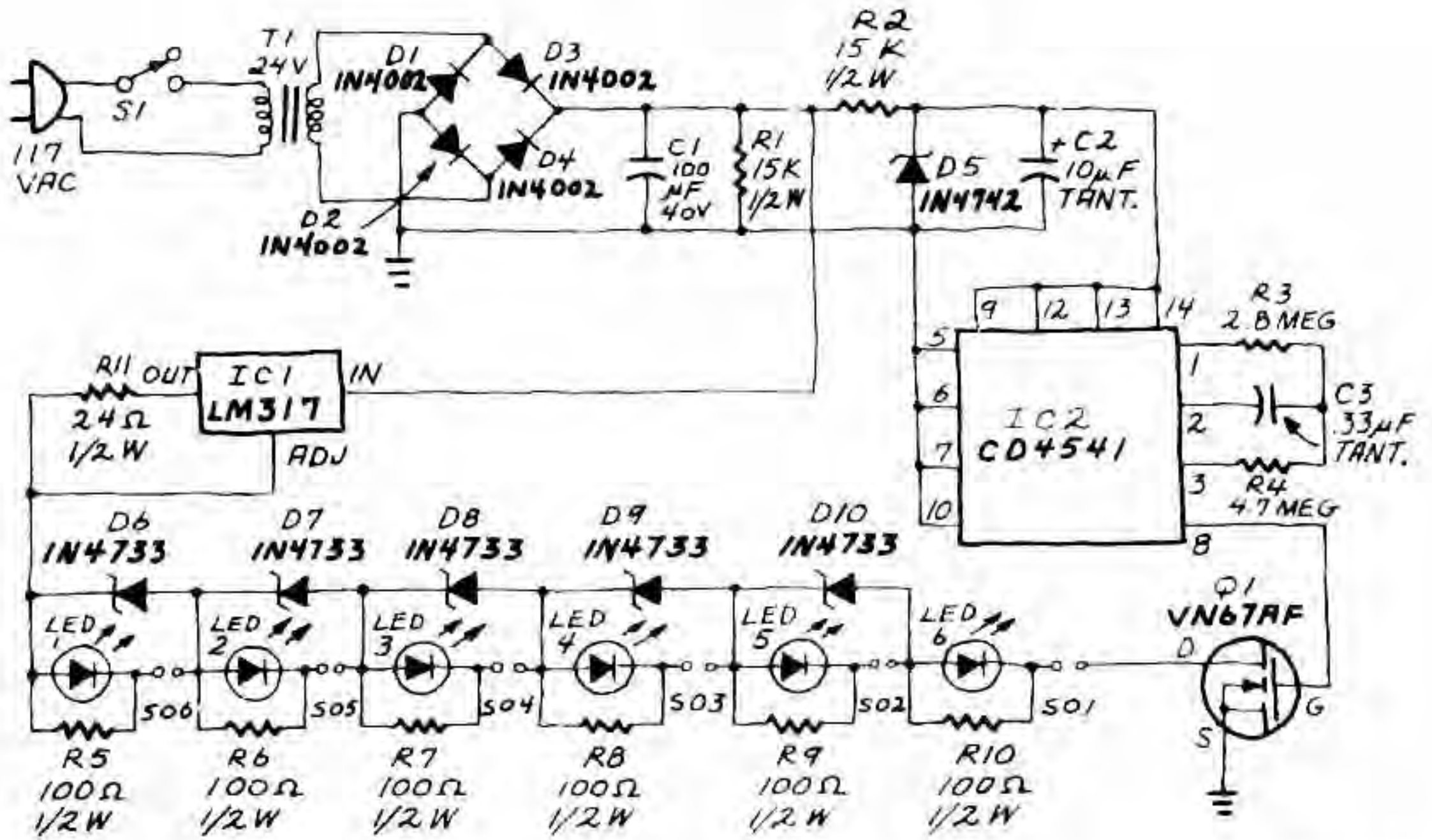

RADIO-ELECTRONICS

Fig. 1-21

An LM317 voltage regulator is configured as a constant-current source. It is used to supply the 50-mA charging current to S01-S06, an array of AA-cell battery holders. Each of the battery holders is wired in series with an LED and its associated shunt resistor. When the battery holder contains a battery, the LED glows during charging. Each battery holder/LED combination is paralleled by a 5.1-V zener diode. If the battery holder is empty, the zener conducts the current around the holder.

A timing circuit prevents overcharging. When power is applied to the circuit, timing is initiated by IC2, a CD4541 oscillator/programmable timer. The output of IC2 is fed to Q1. When that output is high, the transistor is on, and the charging circuit is completed. When the output is low, the transistor is off, and the path to ground is interrupted.

GEL-CELL CHARGER

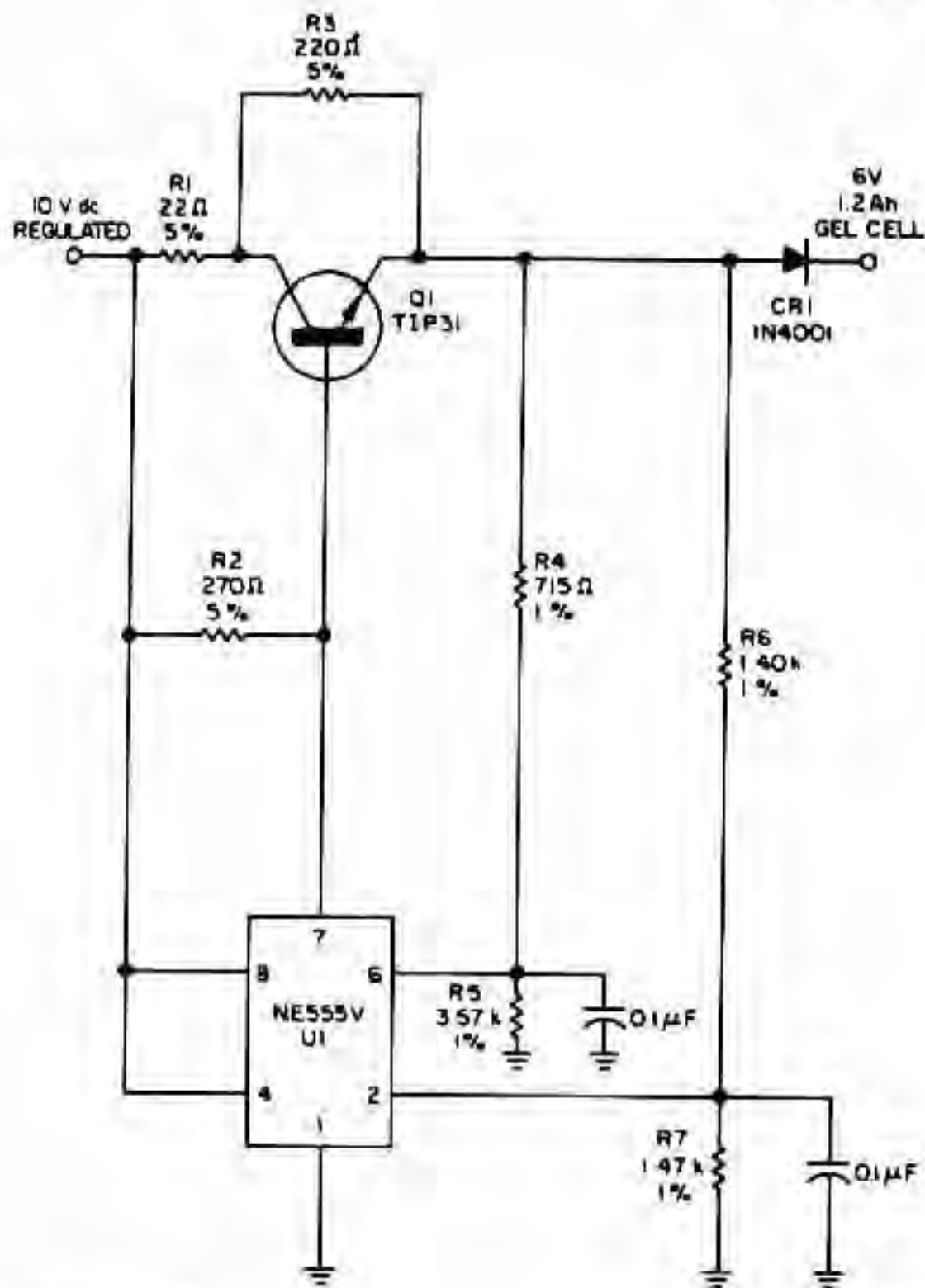

This circuit detects a full-charge state and automatically switches to a float condition—from 240 to 12 mA.

ELECTRONIC DESIGN

Fig. 1-22

NICAD BATTERY ZAPPER

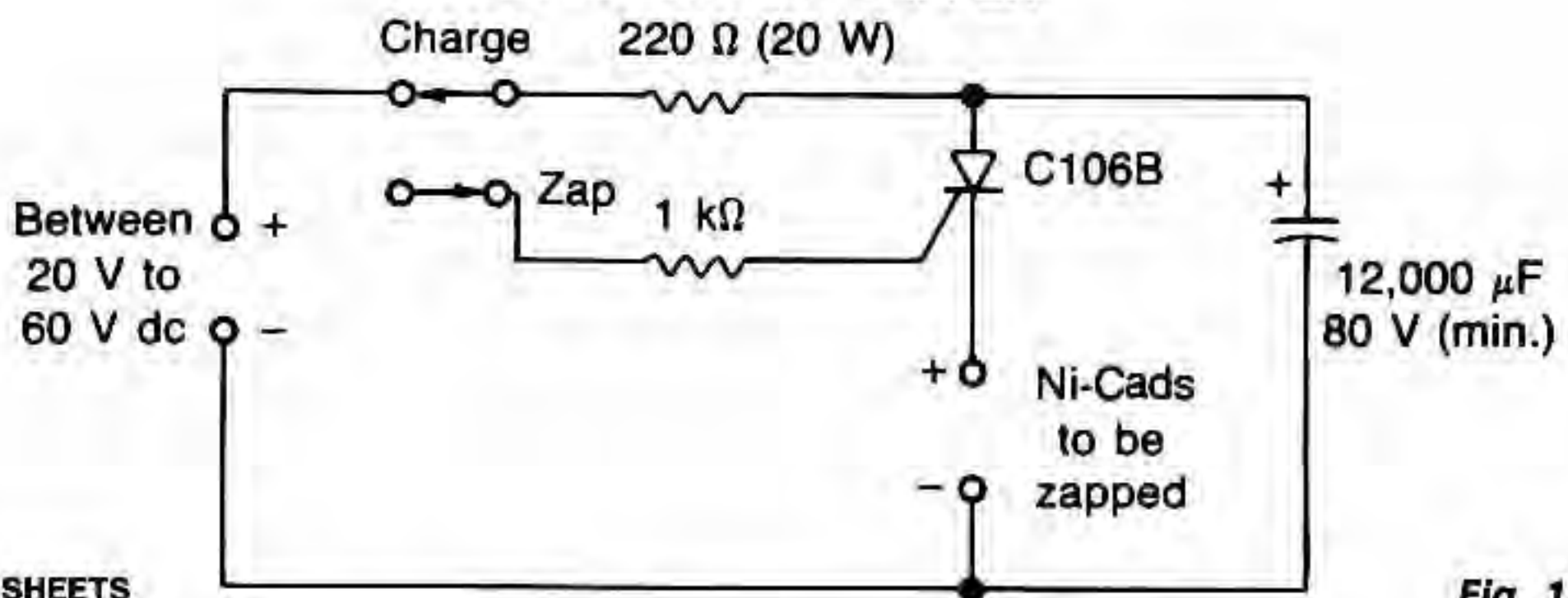

WILLIAM SHEETS

Fig. 1-23

The short in a NiCad battery can be "burned off" with this zapper. Use of the SCR keeps heavy discharge current from damaging switch contacts.

THERMALLY CONTROLLED NICAD CHARGER

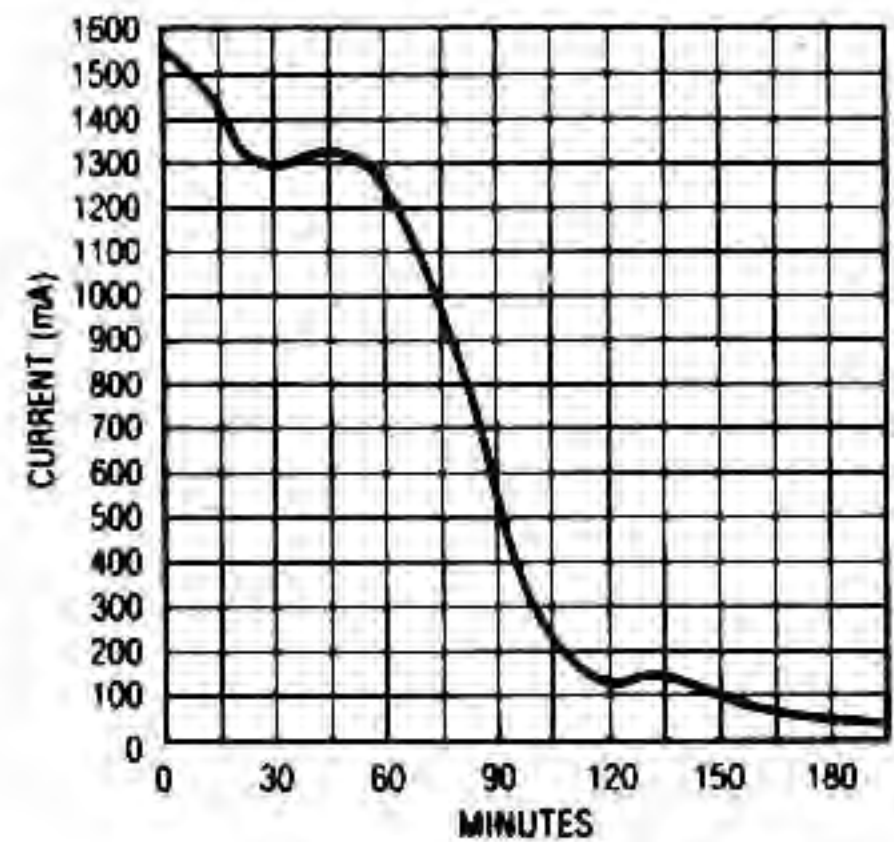
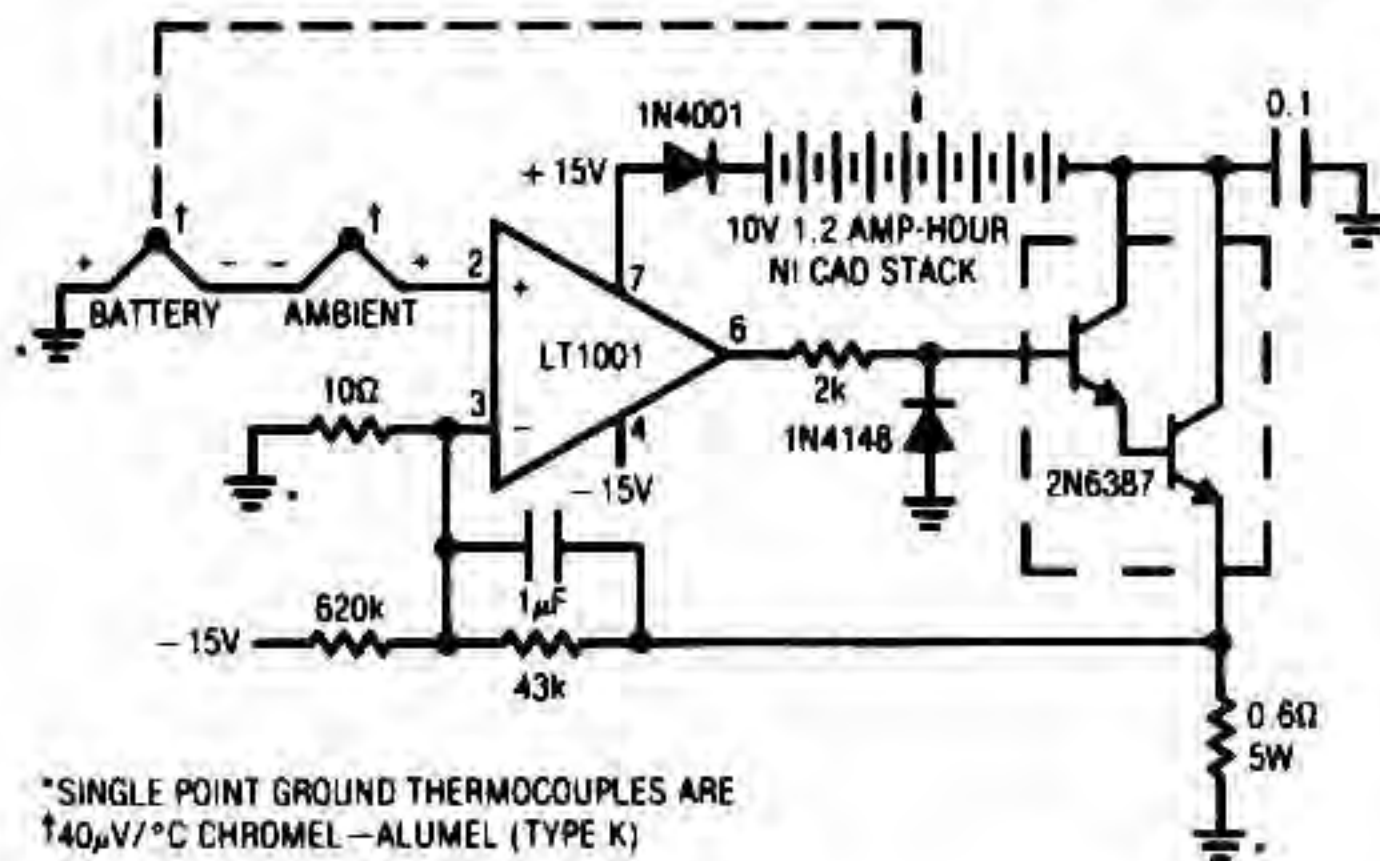

LINEAR TECHNOLOGY CORP.

Fig. 1-24

One way to charge NiCad batteries rapidly without abuse is to measure cell temperature and taper the charge accordingly. The circuit uses a thermocouple for this function. A second thermocouple nulls out the effects of ambient temperature. The temperature difference between the two thermocouples determines the voltage, which appears at the amplifier's positive input. As battery temperature rises, this small negative voltage (1°C difference between the thermocouples equals $40\mu\text{V}$) becomes larger. The amplifier, operating at a gain of 4300, gradually reduces the current through the battery to maintain its inputs at balance. The battery charges at a high rate until heating occurs and the circuit then tapers the charge. The values given in the circuit limit the battery-surface temperature rise over ambient to about 5°C .

NICAD BATTERY ZAPPER II

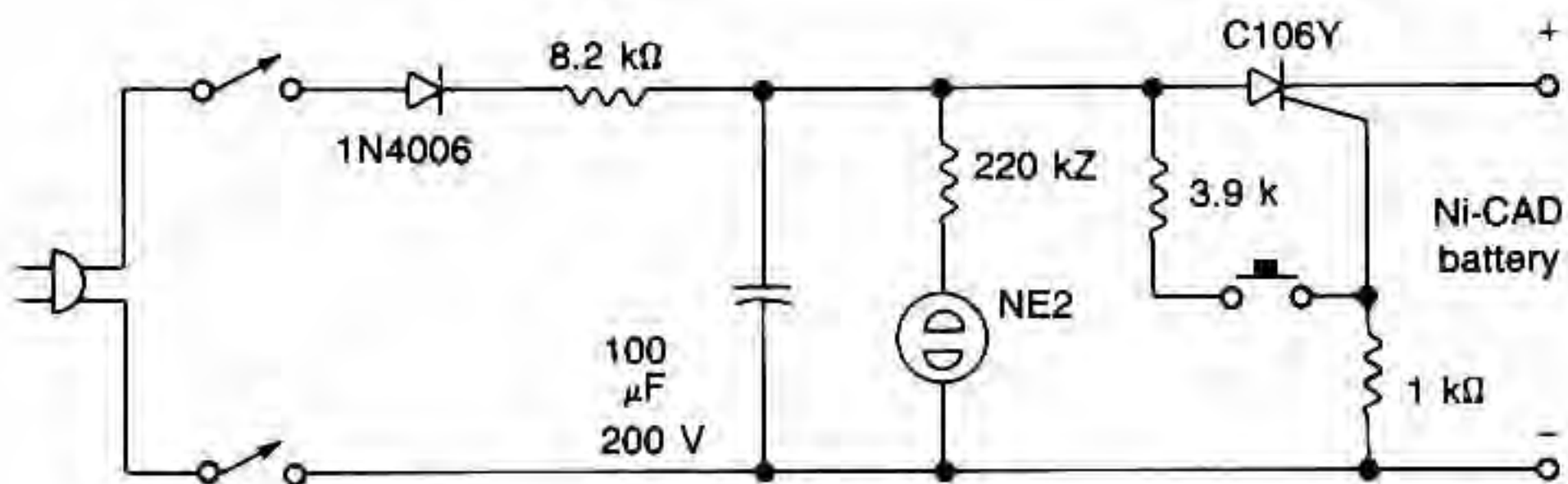

WILLIAM SHEETS

Fig. 1-25

This zapper clears internal shorts in nickel-cadmium batteries by burning them away. CAUTION: The negative battery terminal is connected to one side of the ac line. For safe operation, use a 1:1 isolation transformer.

PUT BATTERY CHARGER

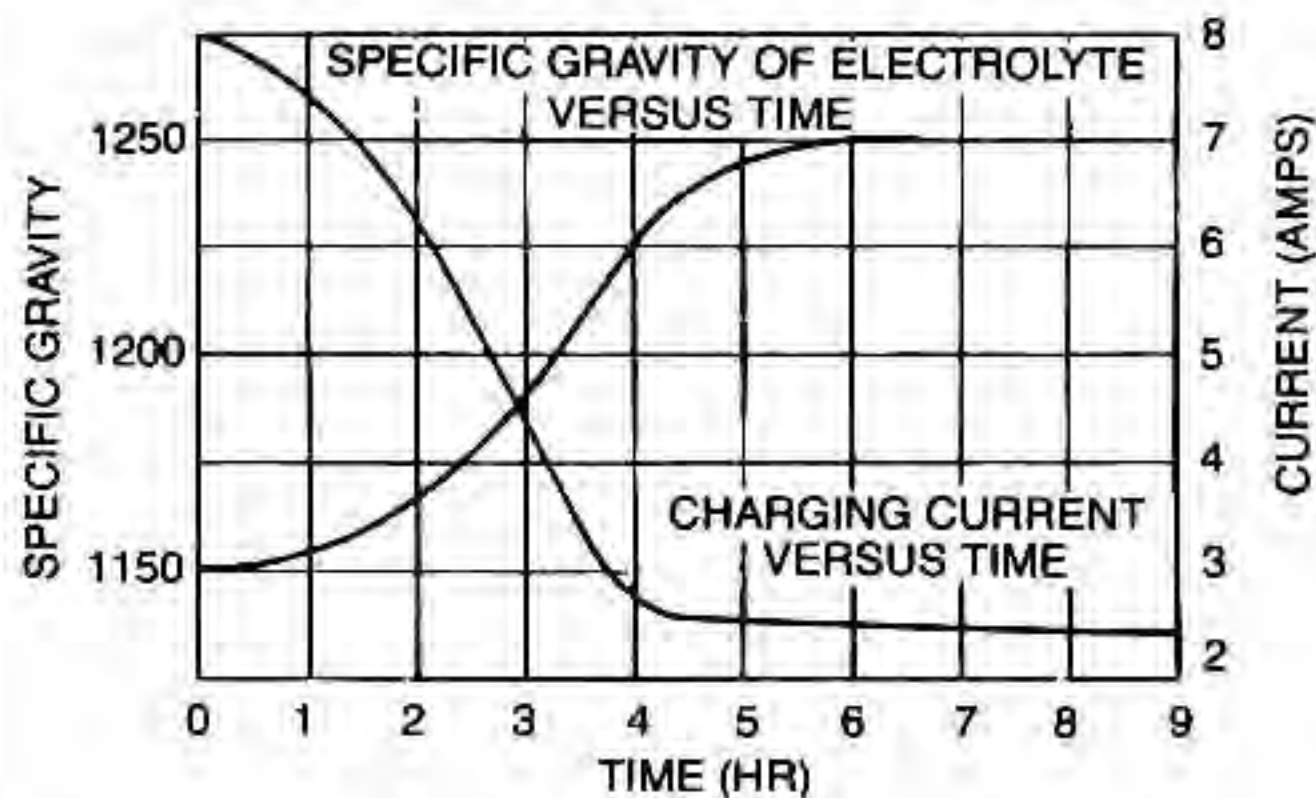
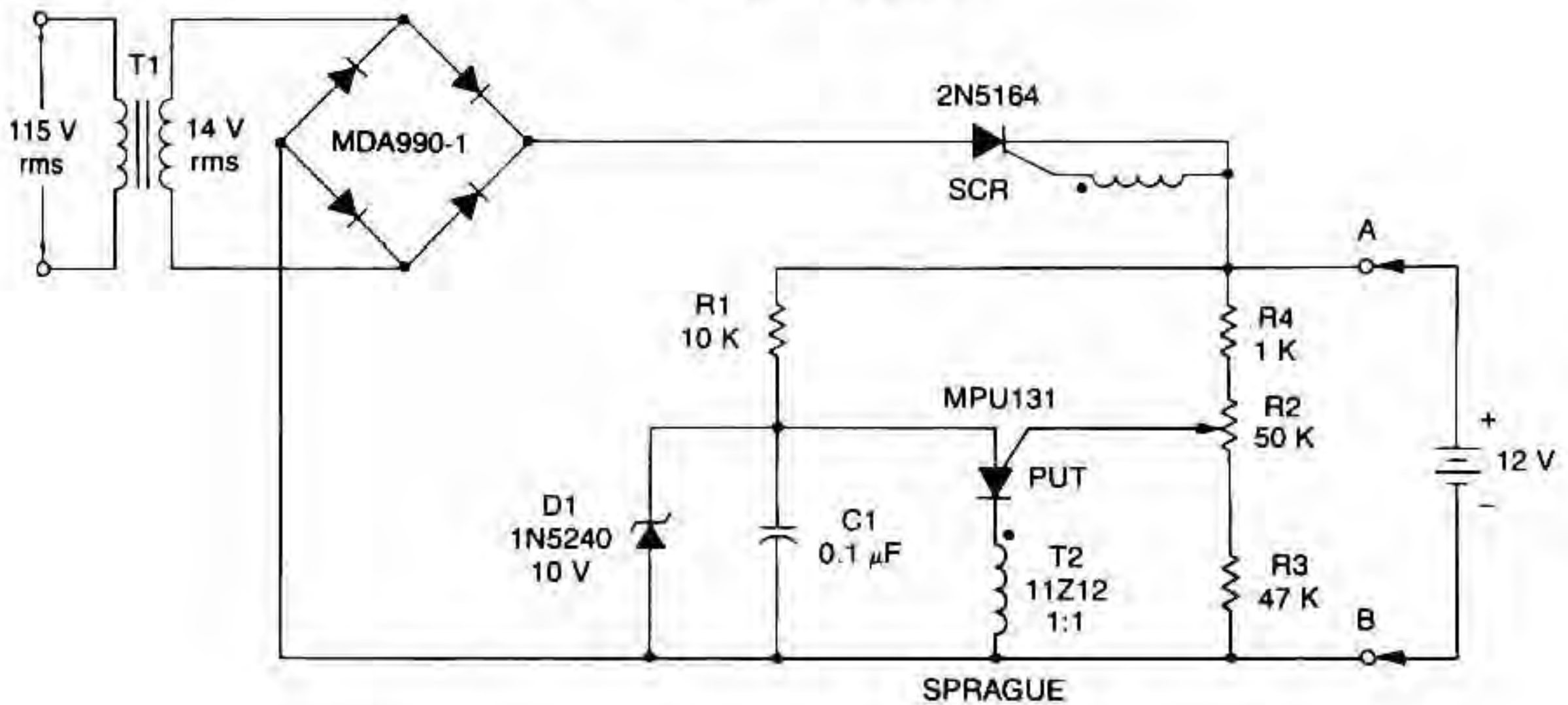

MOTOROLA

Fig. 1-26

A short-circuit-proof battery charger will provide an average charging current of about 8 A to a 12-V lead/acid storage battery. The charger circuit has an additional advantage; it will not function nor will it be damaged by improperly connecting the battery to the circuit. With 115 V at the input, the circuit commences to function when the battery is properly attached. The battery provides the current to charge the timing capacitor C1 used in the PUT relaxation oscillator. When C1 charges to the peak point voltage of the PUT, the PUT fires turning the SCR on, which in turn applies charging current to the battery. As the battery charges, the battery voltage increases slightly which increases the peak point voltage of the PUT. This means that C1 has to charge to a slightly higher voltage to fire the PUT. The voltage on C1 increases until the zener voltage of D1 is reached, which clamps the voltage on C1, and thus prevents the PUT oscillator from oscillating and charging ceases. The maximum battery voltage is set by potentiometer R2 which sets the peak point firing voltage of the PUT. In the circuit shown, the charging voltage can be set from 10 V to 14 V—the lower limit being set by D1 and the upper limit by T1.

PORTABLE NICAD BATTERY CHARGER

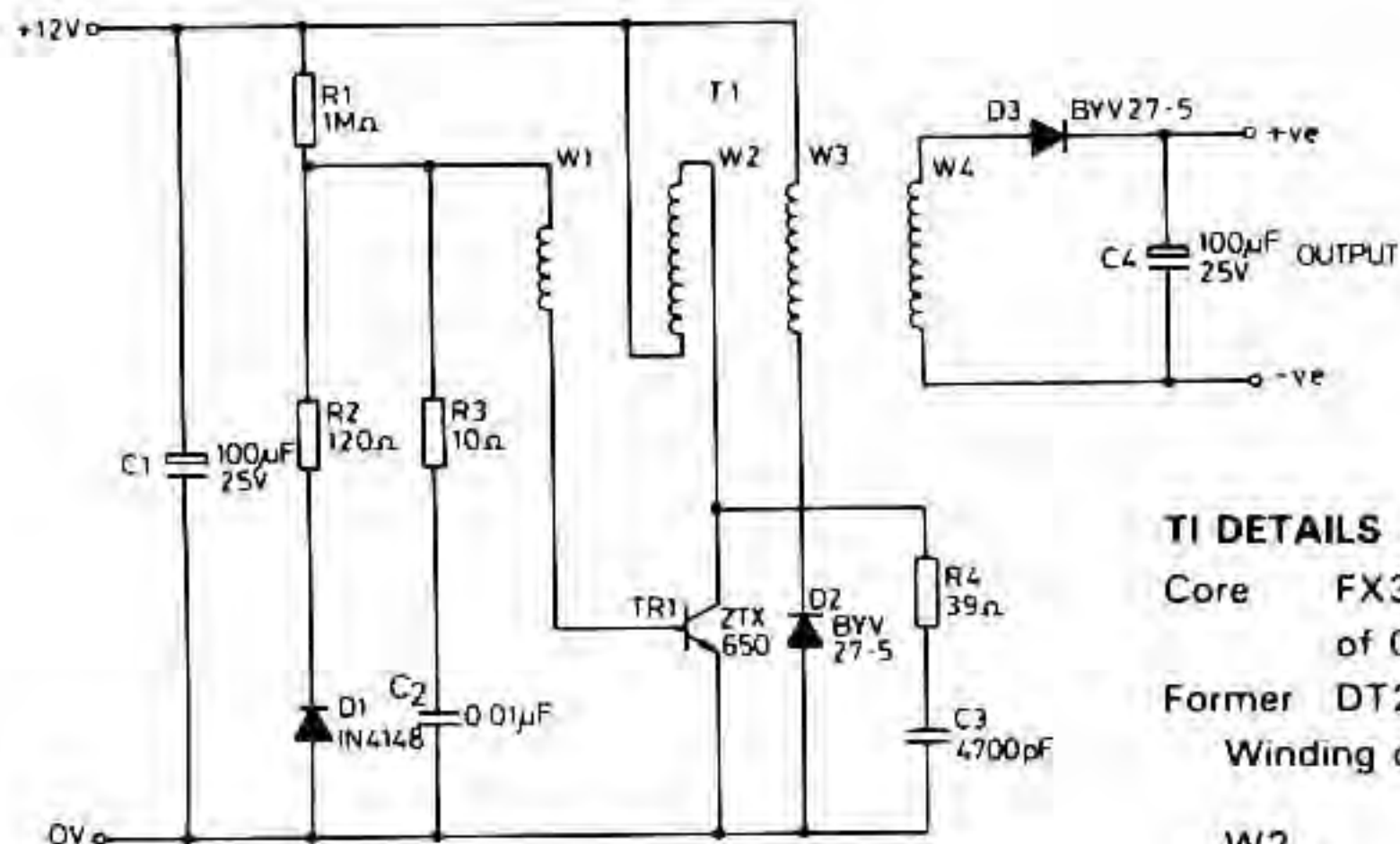

TI DETAILS

Core FX3437 With Gap/Spacer
of 0.08mm

Former DT2492

Winding order W2, W4, W3 then W1

W2	40T	30awg.
W4	20T	30awg.
W3	13T	36awg.
W1	12T	36awg.

ZETEX (formerly FERRANTI)

Fig. 1-27

This circuit was designed to charge NiCad battery packs in the range of 4.8 to 15.6 V from a convenient remote power source, such as an automobile battery. When power is first applied to the circuit, a small bias current supplied by R1 via winding W1, starts to turn on the transistor TR1. This forces a voltage across W2 and the positive feedback given by the coupling of W1 and W2 causes the transistor to turn hard on, applying the full supply across W2. The base drive voltage induced across W1 makes the junction between R1 and R2 become negative with respect to the 0-V supply, forward-biasing diode D1 to provide the necessary base current to hold TR1 on.

With the transistor on, a magnetizing current builds up in W2, which eventually saturates the ferrite core of transformer T1. This results in a sudden increase on the collector current flowing through TR1, causing its collector-emitter voltage to rise, and thus reducing the voltage across W2. The current flowing in W2 forces the collector voltage of the TR1 to swing positive until restricted by transformer output loading. R_c network R4 and C3 limits the turn off transient TR1. R3 and C2 maintain the loop gain of the circuit when diode D1 is not conducting.

LITHIUM BATTERY CHARGER

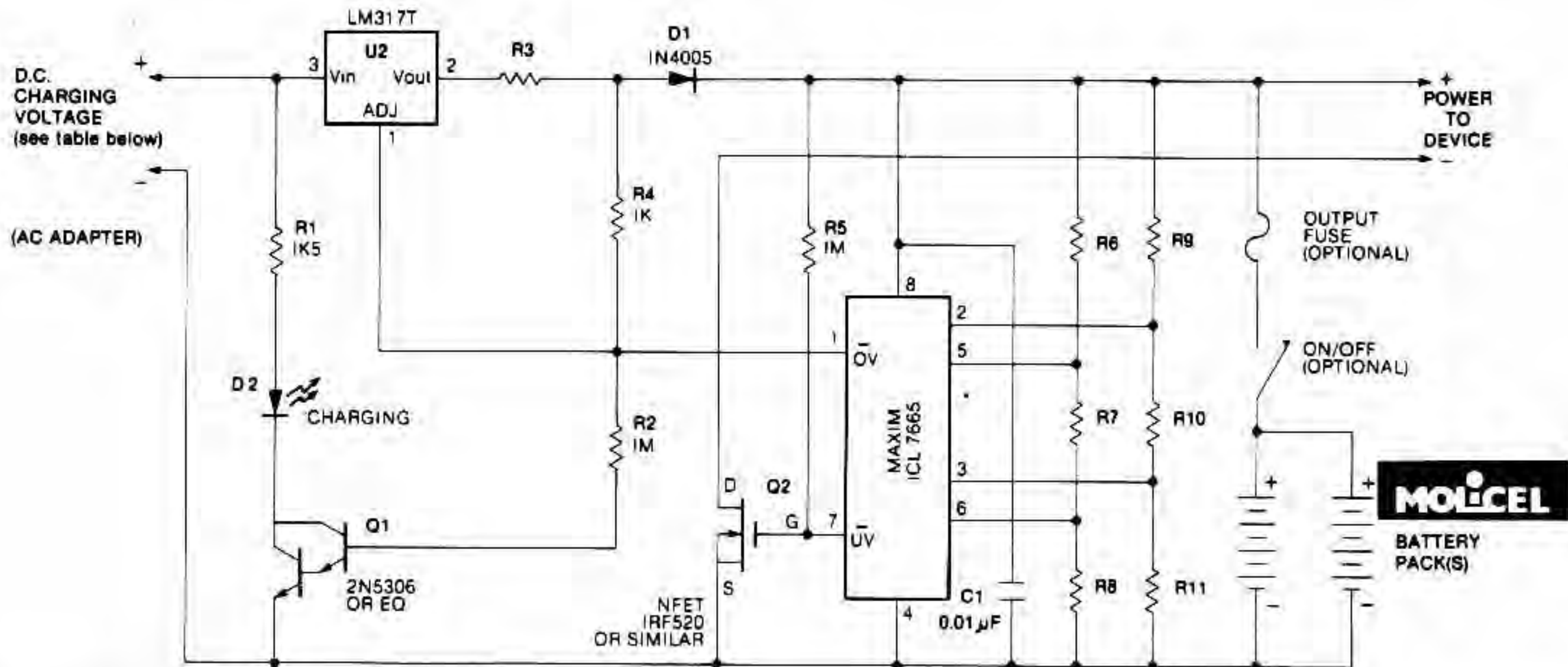

MOLI ENERGY LIMITED

Fig. 1-28

Charging is accomplished with a constant current of 60 mA for AA cells to a cutoff voltage of 2.4 V per cell, at which point the charge must be terminated. The charging system shown is designed for multi-cell battery packs of 2 to 6 series-connected cells or series/parallel arrangements. It is essential that all cells assembled in the pack are at an identical state-of-charge (voltage) before charging. The maximum upper cut-off voltage is 15.6 V (6×2.6 V).

RAPID BATTERY CHARGER FOR ICOM IC-2A

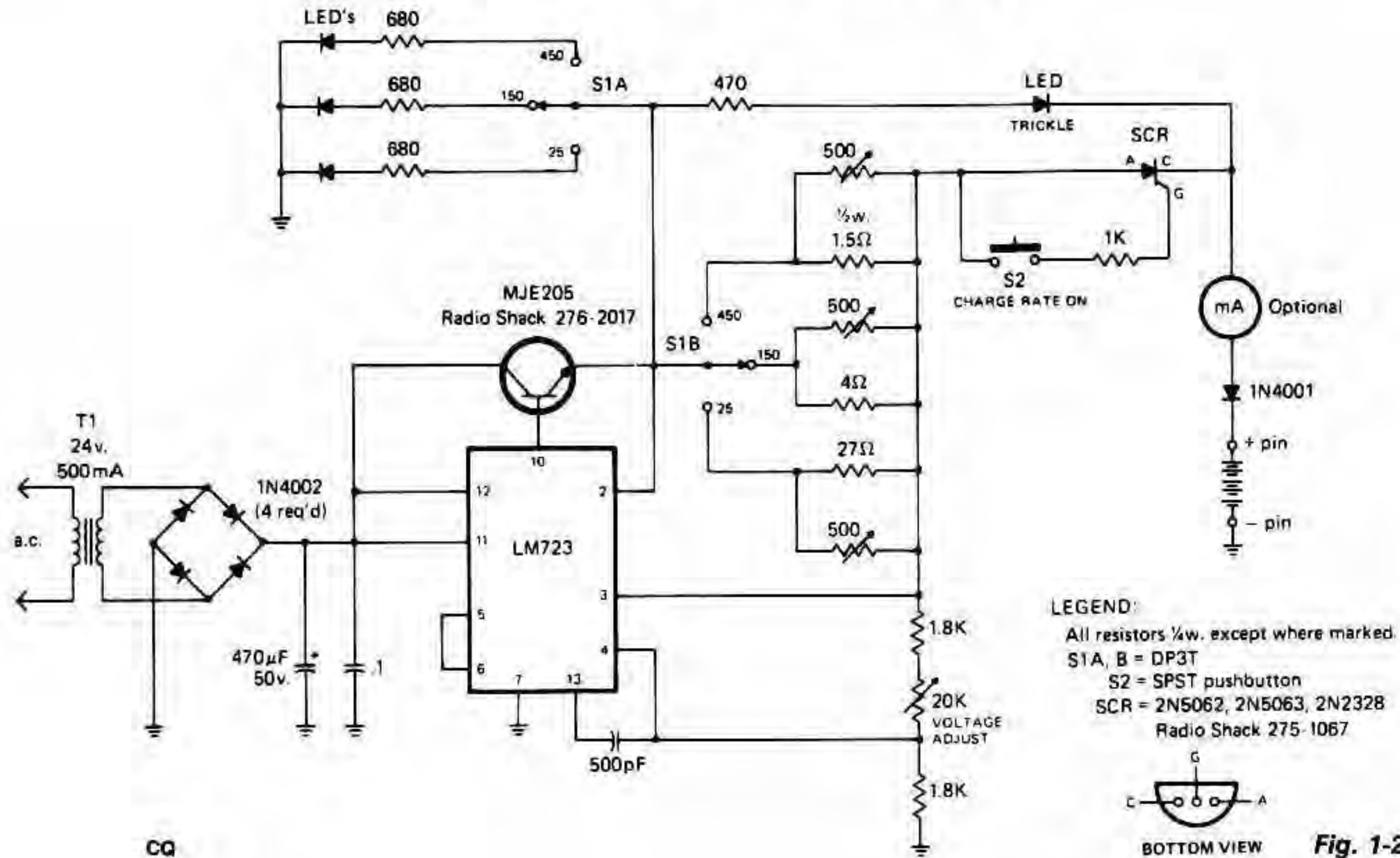

Rectified and filtered voltage from the 24-Vac transformer is applied to the LM723 voltage regulator and the npn pass transistor set up for constant current supply. The 470-Ω resistor limits trickle current until the momentary pushbutton (S2) is depressed, the SCR turns on, and current flows through the previously determined resistor network, which limits the charging current. The SCR will turn off when the thermal cutout circuit inside the battery pack opens up.

BATTERY CHARGER OPERATES ON SINGLE SOLAR CELL

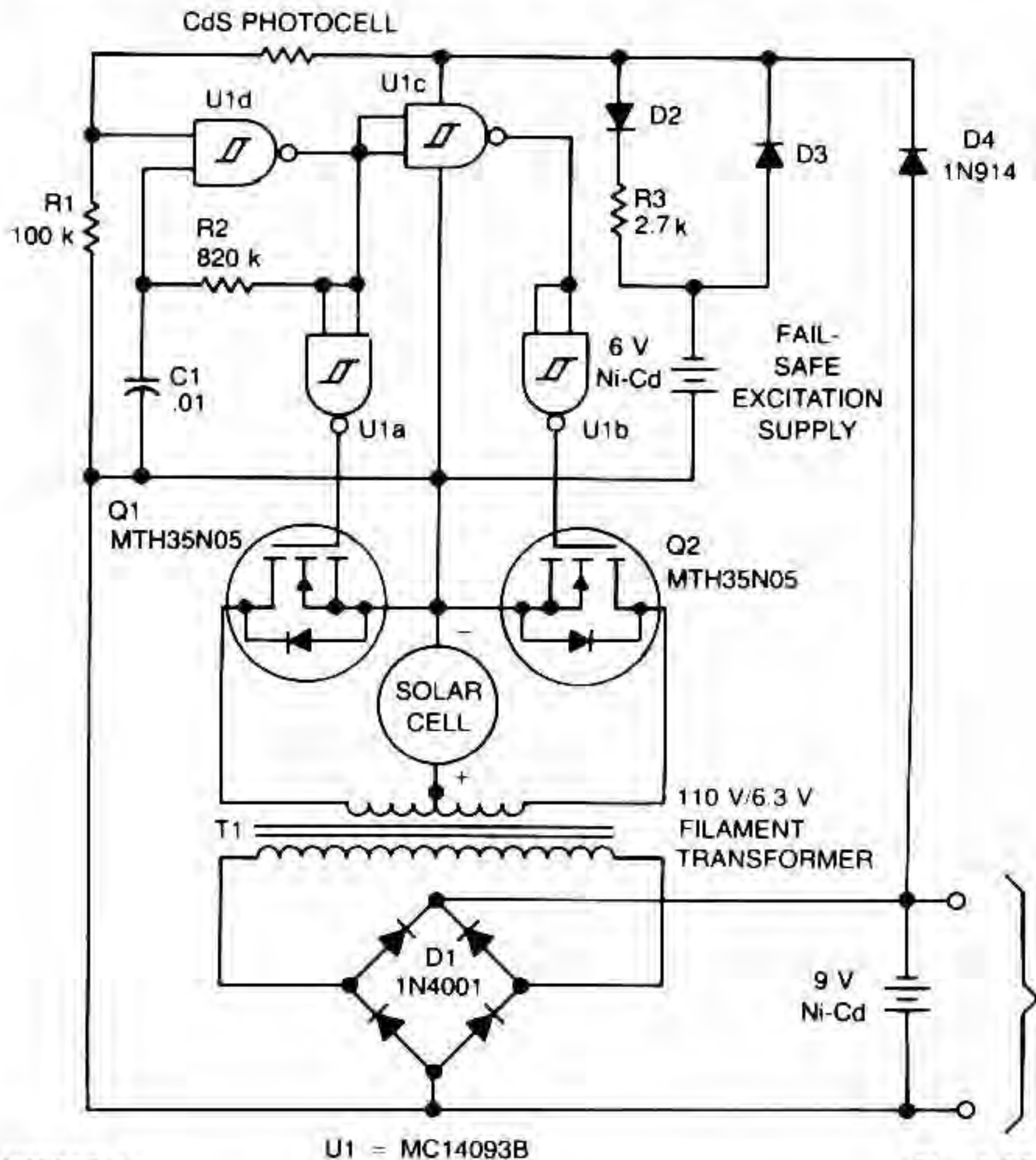

MOTOROLA

Fig. 1-30

The circuit charges a 9-V battery at about 30 mA per input ampere at 0.4 V. U1, a quad Schmitt trigger, operates as an astable multivibrator to drive push-pull TMOS devices, Q1 and Q2. Power for U1 is derived from the 9-V battery via D4; power for Q1 and Q2 is supplied by the solar cell. The multivibrator frequency, determined by R2/C1, is set to 180 Hz for maximum efficiency from a 6.3-V filament transformer, T1. The secondary of the transformer is applied to a full-wave bridge rectifier, D1, which is connected to the batteries being charged. The small NiCad battery is a fail-safe excitation supply to allow the system to recover if the 9-V battery becomes fully discharged.

A CdS photocell shuts off the oscillator in darkness to preserve the fail-safe battery during shipping, storage, and prolonged darkness.

WIND-POWERED BATTERY CHARGER

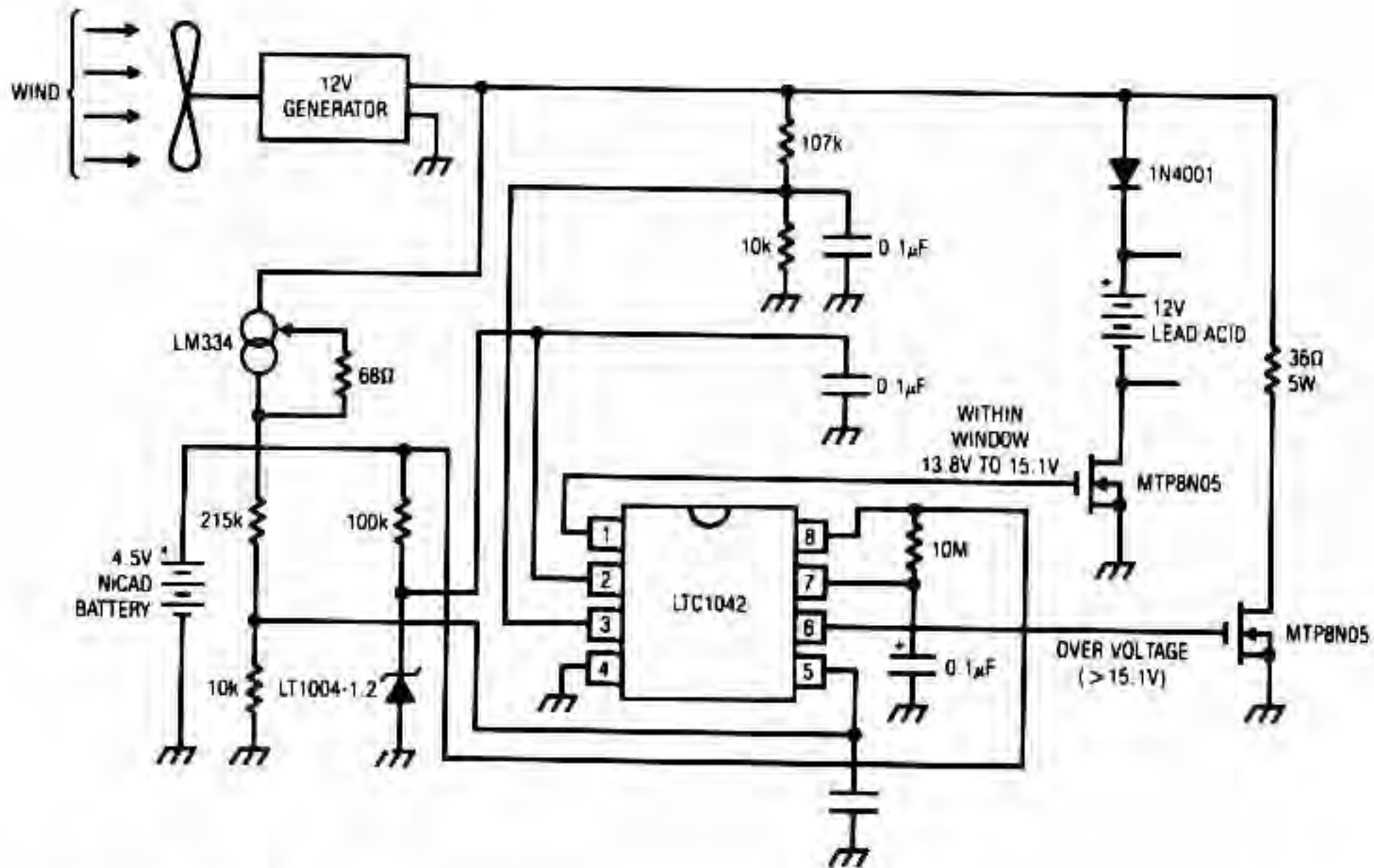

LINEAR TECHNOLOGY

Fig. 1-31

The dc motor is used as a generator; the voltage output is proportional to its rpm. The LTC1042 monitors the voltage output and provides the following control functions.

1. If generator voltage output is below 13.8 V, the control circuit is active and the NiCad battery is charging through the LM334 current source. The lead-acid battery is not being charged.
2. If the generator voltage output is between 13.8 and 15.1 V, the 12-V lead-acid battery is being charged at about 1-amp/hour rate (limited by the power FET).
3. If generator voltage exceeds 15.1 V (a condition caused by excessive wind speed or when the 12-V battery is fully charged), then a fixed load is connected, which limits the generator rpm to prevent damage.

This charger can be used as a remote source of power where wind energy is plentiful, such as on sailboats or at remote radio repeater sites. Unlike solar-powered panels, this system will function in bad weather and at night.