

K.I.S.S. Trickle Charger

And the ABCs of battery maintenance.

After my battery charger article in the March 2000 issue of 73 Magazine was published, I received dozens of letters, calls, and E-mails asking if some chargers might OVERCHARGE some batteries. The simple answer is "YES."

When we have a discharged battery, we generally want to quickly recharge it and get it back in service as soon as possible. The only way to achieve that is to use a charger with a high current output. But high current creates heat and heat destroys batteries.

In the 1960s, Motorola developed the famous HT 200 "BRICK" handie-talkie, and the charger was as simple as it could get. A transformer, a diode, a pilot light, a line cord, a fuse, and a case to put it all in. There was no filter capacitor. The pilot light was used to limit the amount of current that would charge the nicad battery.

When someone discovered that this

circuit could overcharge the battery if left on for an extended period of time, another pilot light and an SPDT switch were added. One light was used for high current and the other for trickle charge.

Fig. 1 is the simple circuit that was used at that time.

Most batteries are "CURRENT" sensitive, not "VOLTAGE" sensitive, except for the relatively new Li-on, "lithium ion" types. These are quite voltage sensitive and SHOULD NOT BE CHARGED IN OTHER THAN AN APPROVED Li-on charger. Limit the current and you can charge most batteries with almost any voltage higher than the rated battery voltage.

Nicad batteries, as well as other types, are rated in ampere hours. Manufacturers rate their batteries according to the chemistry used. One may rate an AA battery at 600 mAh (milliamper hours), while another may rate theirs at 800 mAh. Table 1 shows some examples of popular battery cell manufacturers as they rate their cells.

This means that an 800 mAh battery cell is expected to deliver 800 mA for 1 hour, before dropping to the 1.1 volt per cell rating that is a standard adopted by most of the industry. Some manufacturers say 1 volt per cell. This is true in all nicad battery packs of all sizes and types. If a cell is allowed to

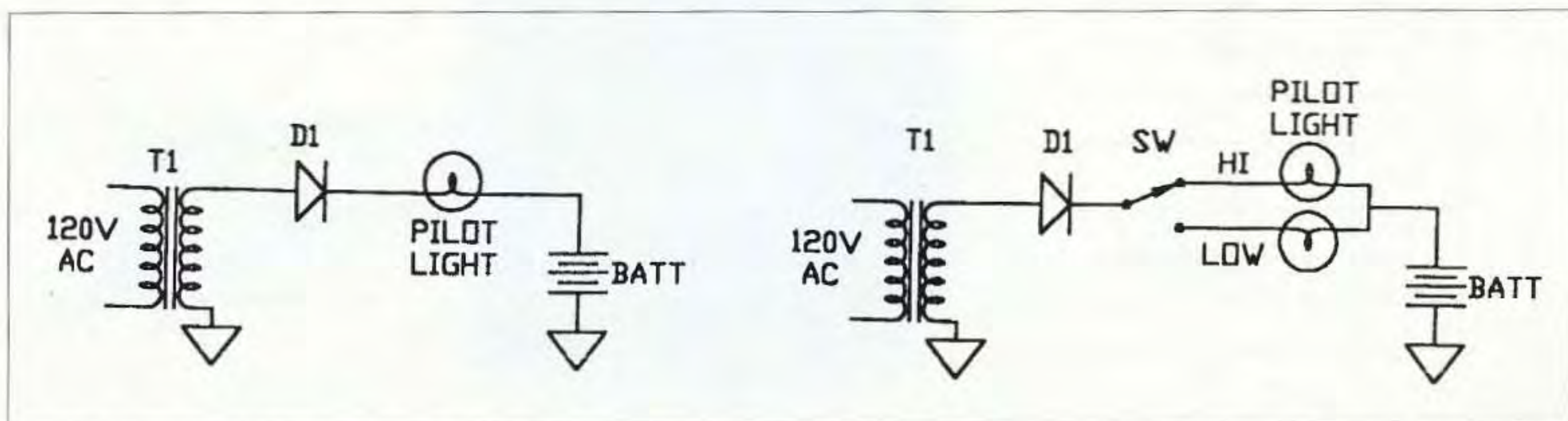

Fig. 1. Motorola HT200 charger circuits.

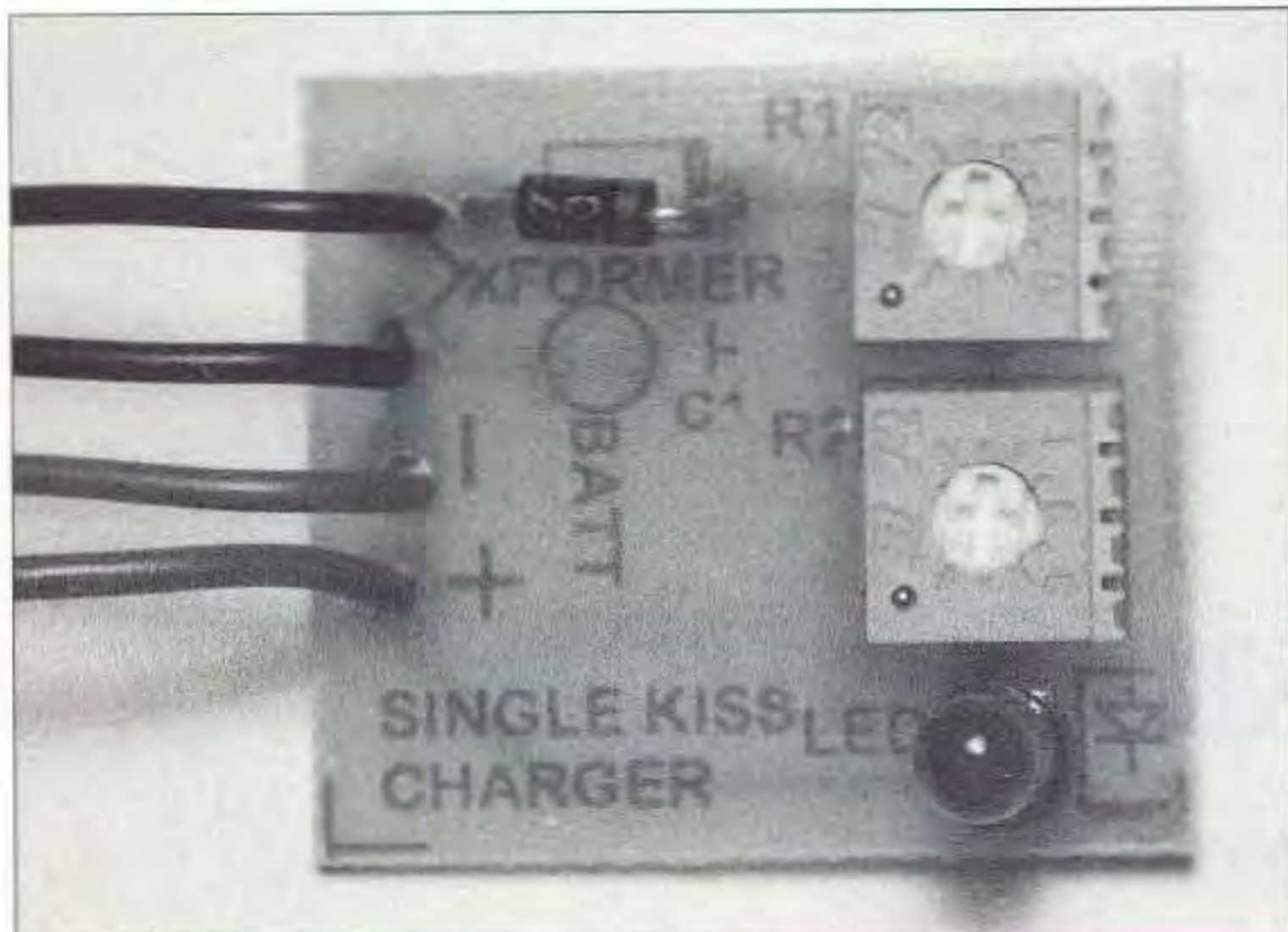

Photo A. Completed single-unit charger.

go to zero volts, there is an 80% to 90% chance of cell voltage reversal, and resulting destruction of that cell. It is

Type	Size	Capacity (mA)
Globtek NiCad	AAA	300
	AA	600-900
	Sub C	1300-1800
	C	2000-2500
	D	4000-4500
Globtek NiMH	AAA	550
	AA	1200
	Sub C	1800-2400
	C	3200-3500
	D	9000
Panasonic NiCad	AAA	250-280
	AA	580-1080
	Sub C	1350-2100
	C	2300-3000
	D	4400-5500
Panasonic NiMH	AAA	550-650
	AA	1000-1500
	Sub C	2800
	C	—
	D	6500
Sanyo NiMH	AAA	730
	AA	1450-1650
	Sub C	2100-3000
	C	—
	D	7300

Table 1. Some examples of popular battery cell manufacturers as they rate their cells.

almost impossible to ever reverse this problem.

Never discharge a battery completely

Most manufacturers of battery-operated equipment such as HTs, camcorders, and laptop computers tell us to "COMPLETELY" discharge the battery once in a

while and then recharge it. Taking this literally, you might be tempted to use a pilot light or a short piece of wire across the terminals to DISCHARGE the battery completely. DON'T DO IT! In most cases this will destroy the battery. What the manufacturers really mean is to use the low voltage indicator that is built into most devices that

shuts down the equipment when the battery reaches approximately 1.1 volts per cell, as an indicator, and to then recharge the battery. They don't mean to run the battery down to zero volts.

Most of us have many battery-operated devices and if we had to have a separate, expensive charger for each of the devices we could fill a small room with the chargers. Would you like to have a charging device that could charge and or maintain charges on AAA, AA, sub C, C, D, and 9-volt types almost all at one time? Well, read on ...

Remember, nicads and most battery types are not voltage-sensitive. Depending on your choice of the power transformer for the circuit, you could easily charge 8 battery cells at one time, except the "D" and 9-volt types. D cell types would need a little more current for trickle charge than the standard 20 mAh LEDs will handle. For the D cells use the high-current 50 mAh LEDs. Use 2 volts per cell to calculate

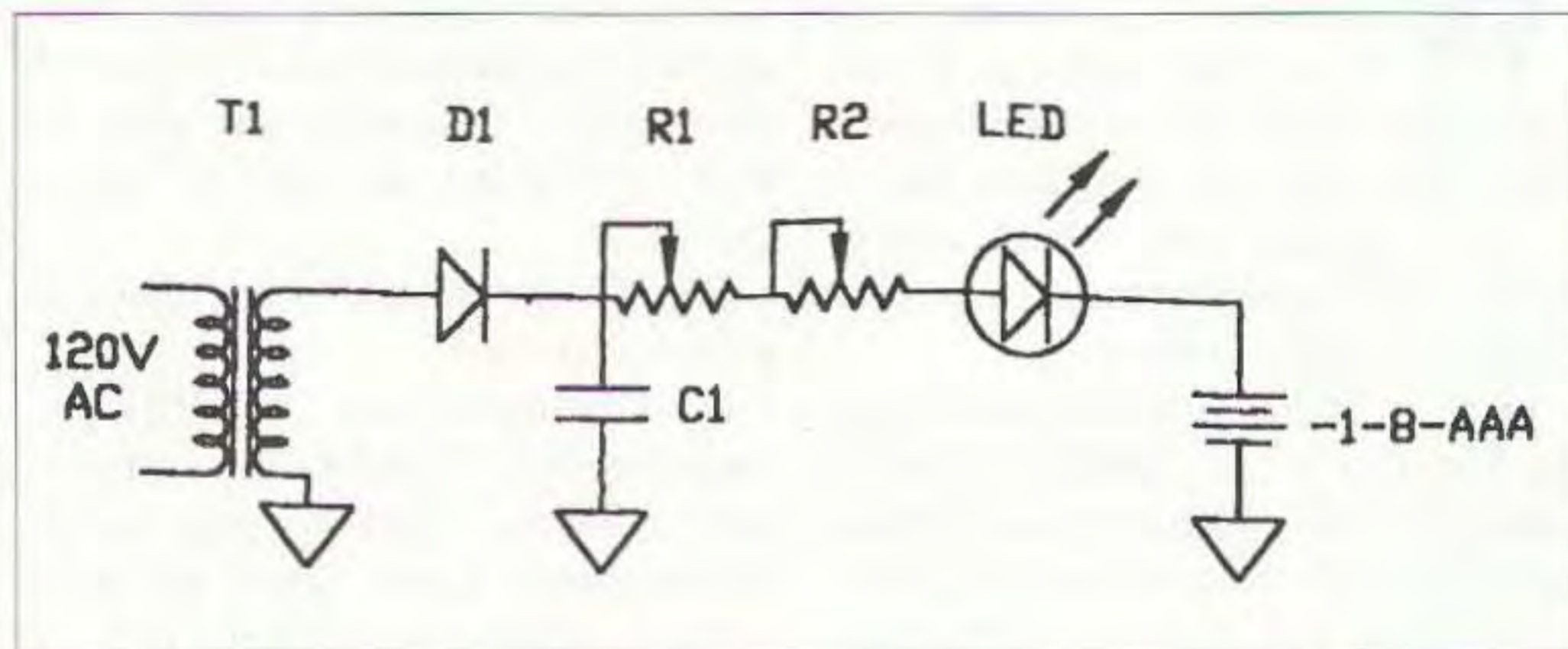

Fig. 2. New charger, single circuit.

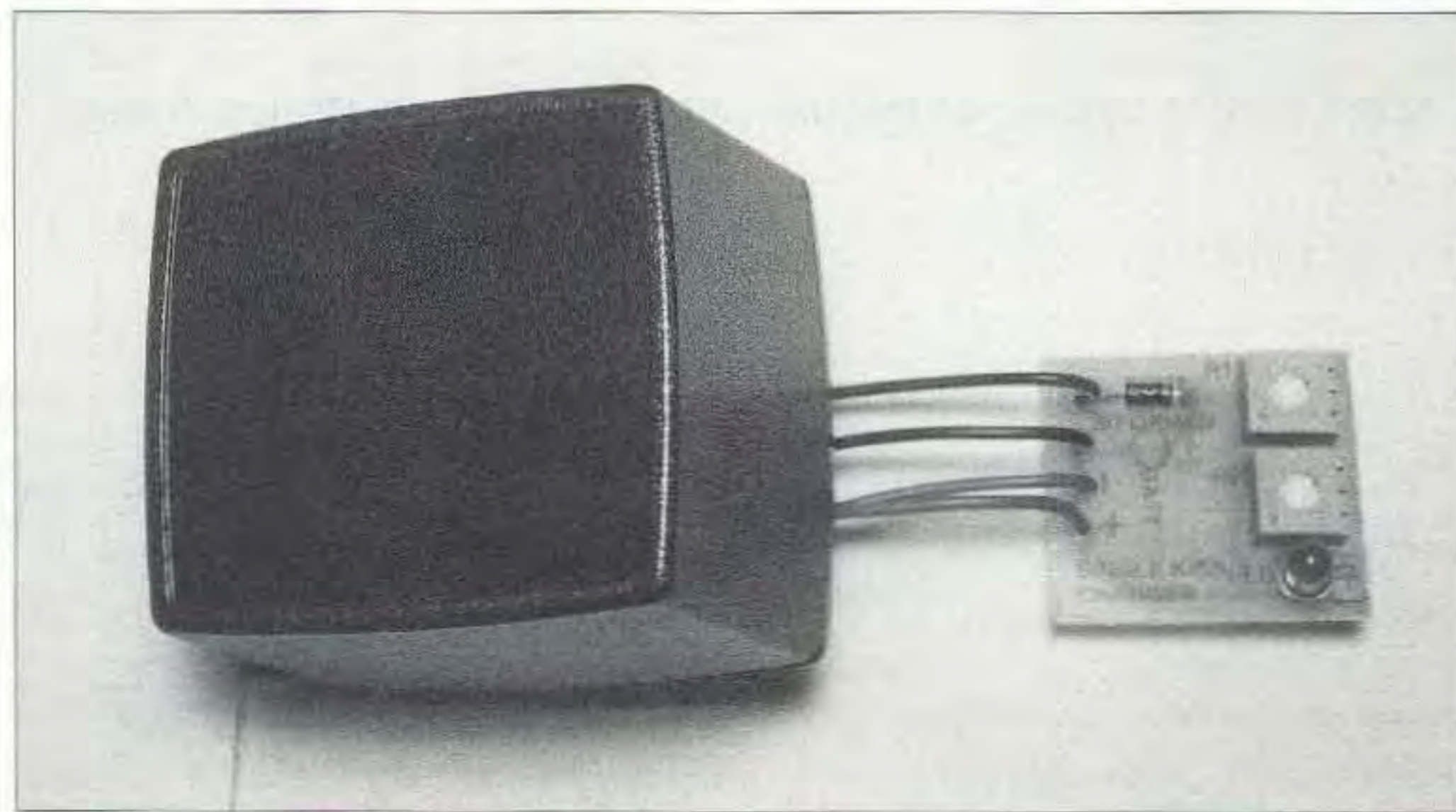

Photo B. Completed single-unit charger with wall-wart-type power supply.

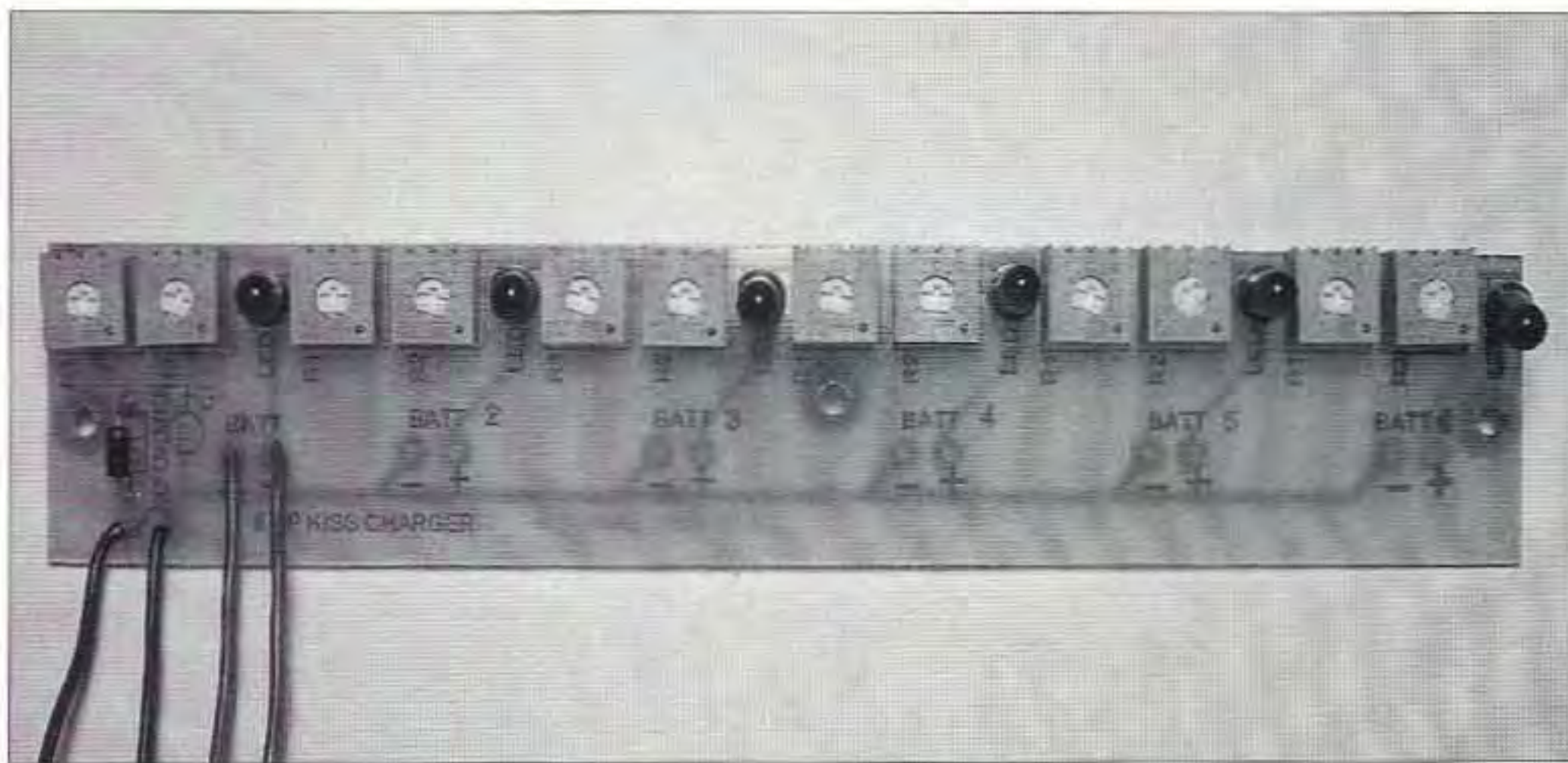

Photo C. Completed six-unit charger.

your transformer size and you won't go wrong. All 9 volt batteries are NOT really 9 volts. There is not enough room in the standard package for enough high current cells for 9 volts. Some battery packs use more lower

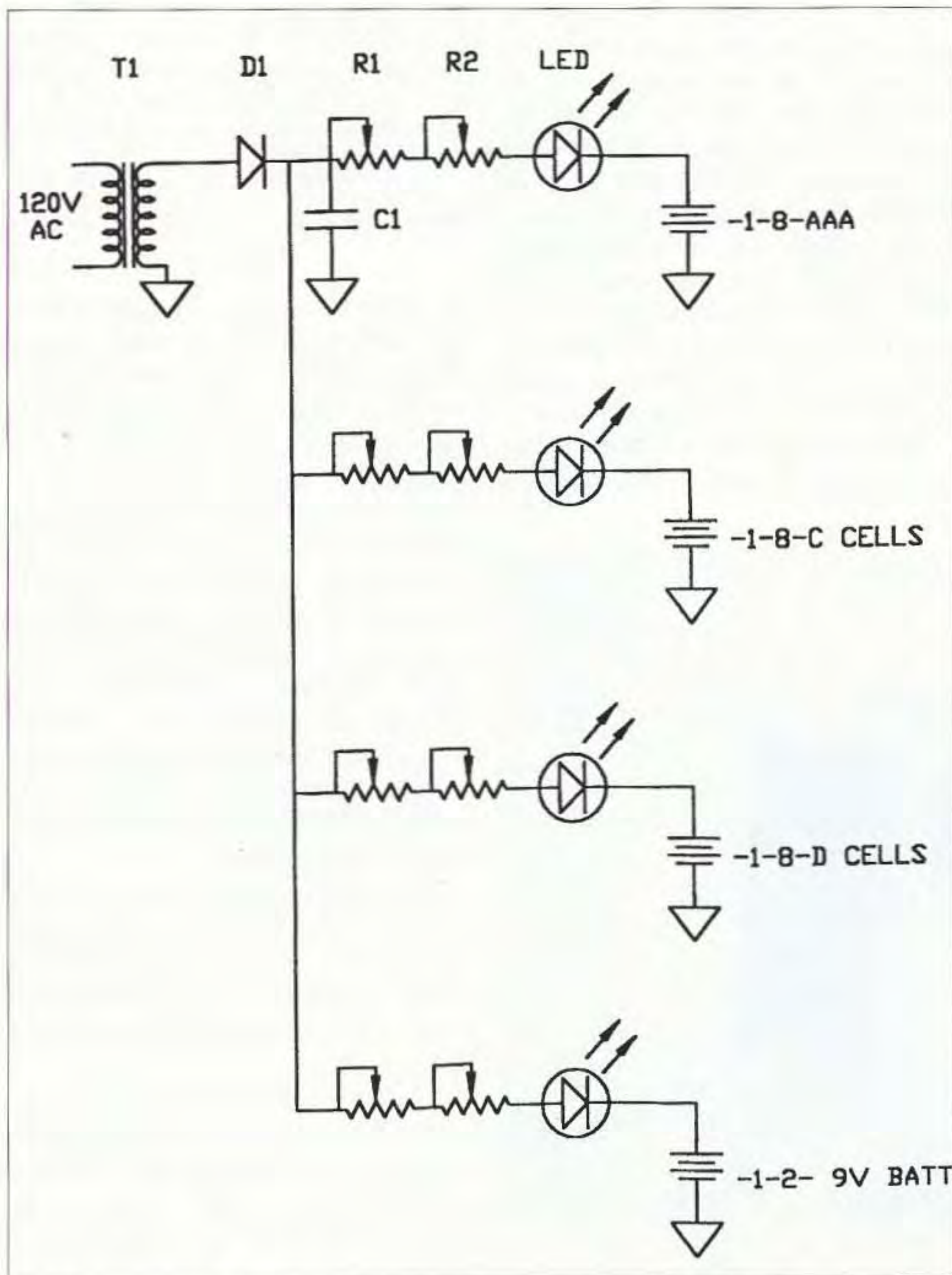

Fig. 3. New charger, 4 circuits.

EVERY ISSUE OF
73 Amateur
Radio Today
on Microfiche!

The entire run of **73** from October 1960 through last year is now available. Over 800 fiche!

You can have access to the treasures of **73** without several hundred pounds of bulky back issues. Our 24x fiche have 98 pages each and will fit in a card file on your desk.

We offer a battery operated hand held viewer for \$150, and a desk model for \$260. Libraries have these readers.

The collection of microfiche, is available as an entire set, (no partial sets) for \$325, plus \$10 shipping (USA). Annual updates available for \$10, plus \$3 shipping/handling. Satisfaction guaranteed or money back!

BUCKMASTER
6196 Jefferson Highway
Mineral, Virginia 23117 USA
540:894-5777 • 800:282-5628
Fax 540:894-9141
e-mail: info@buck.com

**LOW PROFILE HF ANTENNAS
THAT REALLY WORK!**
"Work the World Without Working Up the Neighborhood"

ISOTRON
BILAL COMPANY
Call for a FREE Catalog:
719/687-0650
137 Manchester Dr.
Florissant, CO 80816
www.rayfield.net/isotron

**good deals on
what you want**

- Keeping the FUN in Ham Radio is what we're all about! Since 1980!
- Great prices & customer care on today's major brands, including:

MFJ	DIAMOND	MAHA
QRZ	BATTERY TECH	Hell
GORDON WEST	ARRL	PATCOMM
PROCOMM	TRANSEL	RAMSEY
CALLBOOK	W4RT ELECT.	POWERPORT
IRON HORSE	AND MORE!	MIRACLE
LDG ELECT.		ANTENNA

Call Today
217-352-1725
"Our name says it all!"

Amateur Accessories P.O. Box 7333, Champaign, IL 61826
www.amateuraccessories.com
kr4s@msn.com

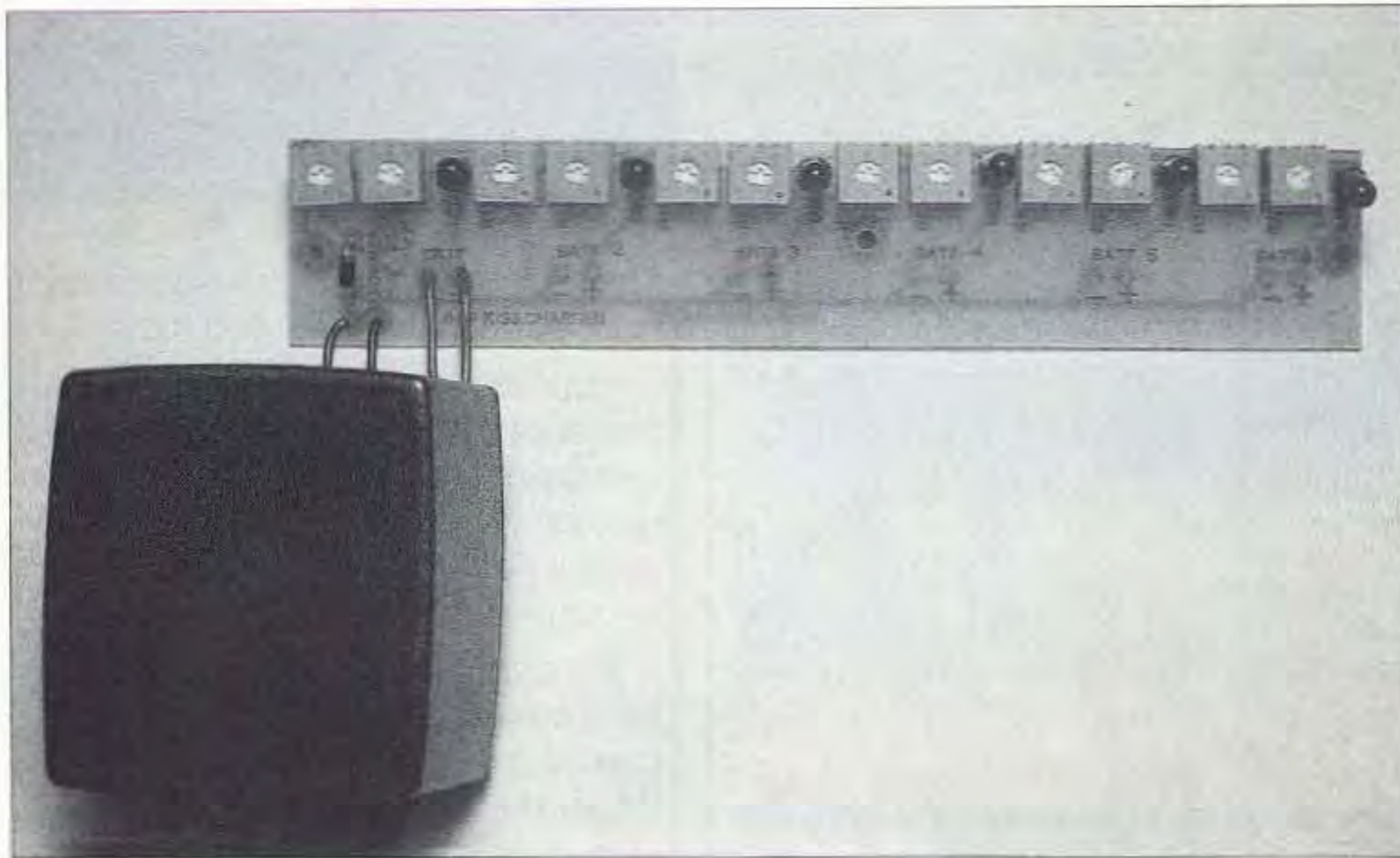

Photo D. Six-unit charger with wall-wart-type power supply.

current cells that add up to 9 volts but have lower current available. Read the battery label carefully.

Let's look at a circuit that will charge and or maintain the health of ALL rechargeable batteries including lead-acid, nicad, and nimh. ALL of these battery types can be charged by limiting the charging current.

Let's use 8 "AA" batteries for starters. So $8 \times 2 \text{ volts} = 16 \text{ volts}$. There are lots of 18-volt transformers available at hamfests, Radio Shack and other stores for not much cost. Look for a "wall wart" or plug-in transformer

with AC or DC output. At this point it won't make any difference which one you find. Either will work in this circuit. The type, AAA to D and the number of cells you want to charge will determine the current capacity of the transformer needed. If you use the single charger circuit, a transformer with only 20–30 mAh capacity is all that's needed. If you use the 4-circuit board and choose to use ALL high-current LEDs, use $4 \times 50 \text{ mAh}$, or about 200–250 mAh transformer capacity.

Batteries are charged with the industry standards in mind. Let's assume the

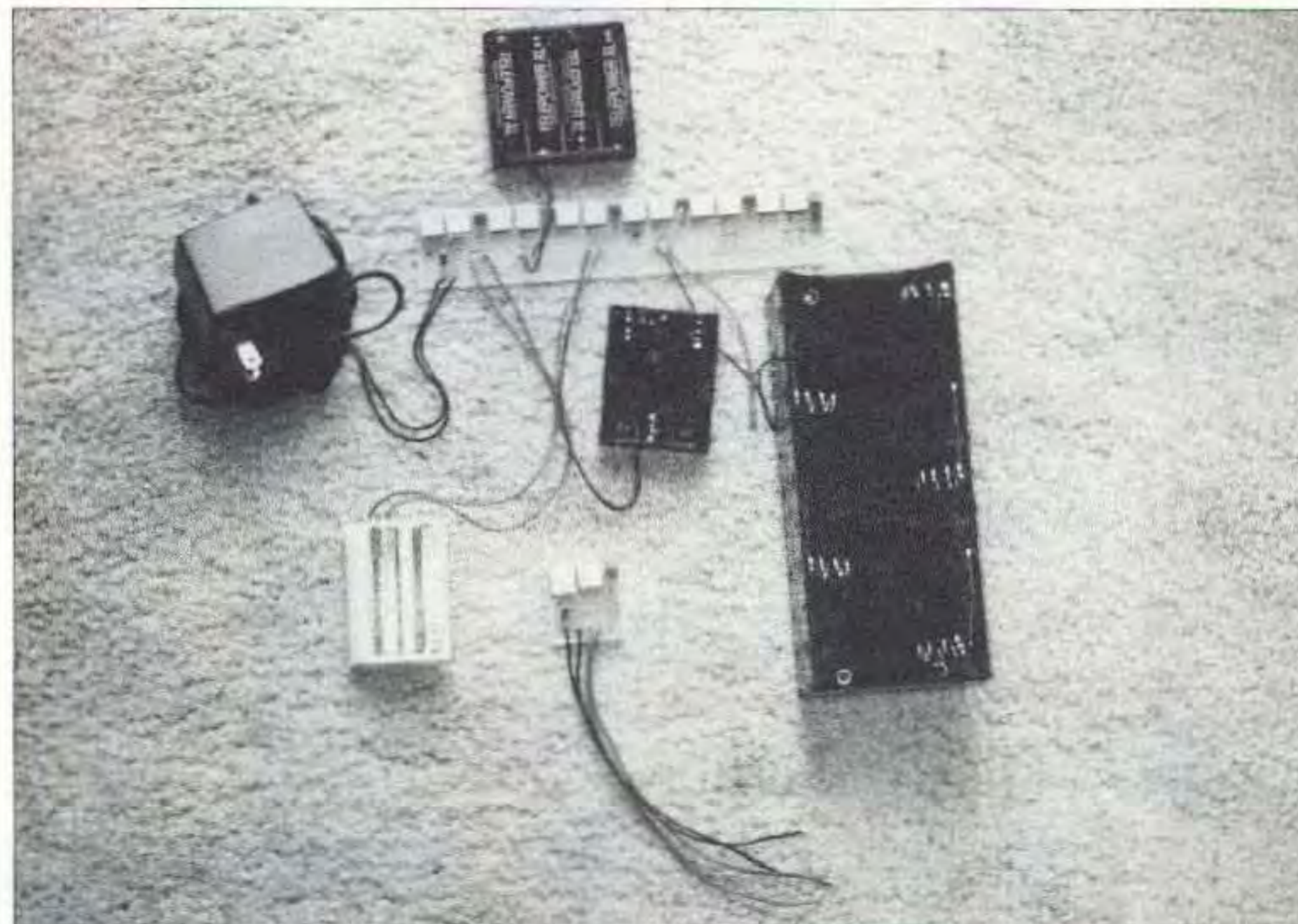

Photo E. This versatile charger is able to charge up to six different configurations of batteries, from single cells to battery packs, all at different voltages and currents at the same time.

Part	Description	Radio Shack #	Cost
T1	Pri 120 VAC, Sec 25 VAC	273-1366	\$5.99
D1	Diode, 2 per pack	276-1102	\$0.59
R1, R2	2k pot, each	900-4673	\$1.19
LED	Regular 20 mA LED, 2 per pack	276-330	\$1.29
	AAA dual battery holder	270-398B	\$0.99
	AAA quad battery holder	270-411	\$1.49
	AA dual battery holder	270-408	\$1.49
	AA quad battery holder	270-391	\$1.69
	C dual battery holder	270-385	\$1.49
	C quad battery holder	270-390	\$1.59
	D dual battery holder	270-386	\$1.69
	D quad battery holder	270-396	\$1.79
C1	Almost any small filter cap	—	—

Table 2. Parts list.

AA cells in the above example are the 800 mAh type. The standard rate of charge is 10% of their rated capacity for 12–14 hours. This comes to approximately 80 mA. Any more, or any longer may damage the battery with excess heat. After the 12–14 hours, at the standard charge rate, use 10% of the standard charge rate or approximately 8–10 mA. The battery at this rate can be charged forever. I have some Dustbusters that have been charged this way for years with NO problems. It might be desirable to have several "maintenance chargers" all going at the same time for maximum utility and usefulness.

Most cells or batteries have the rated capacity indicated on them. From that information you can calculate 10% of rated capacity for the 12–14 hour charge, then 10% of that figure forever after.

The circuit in Fig. 2 is simplicity in itself. If the wall wart supply you are using has a DC output, you save the cost of putting a simple diode and capacitor on the PCB board. Simply put a jumper in place of the diode on the board and leave out the filter cap. If the

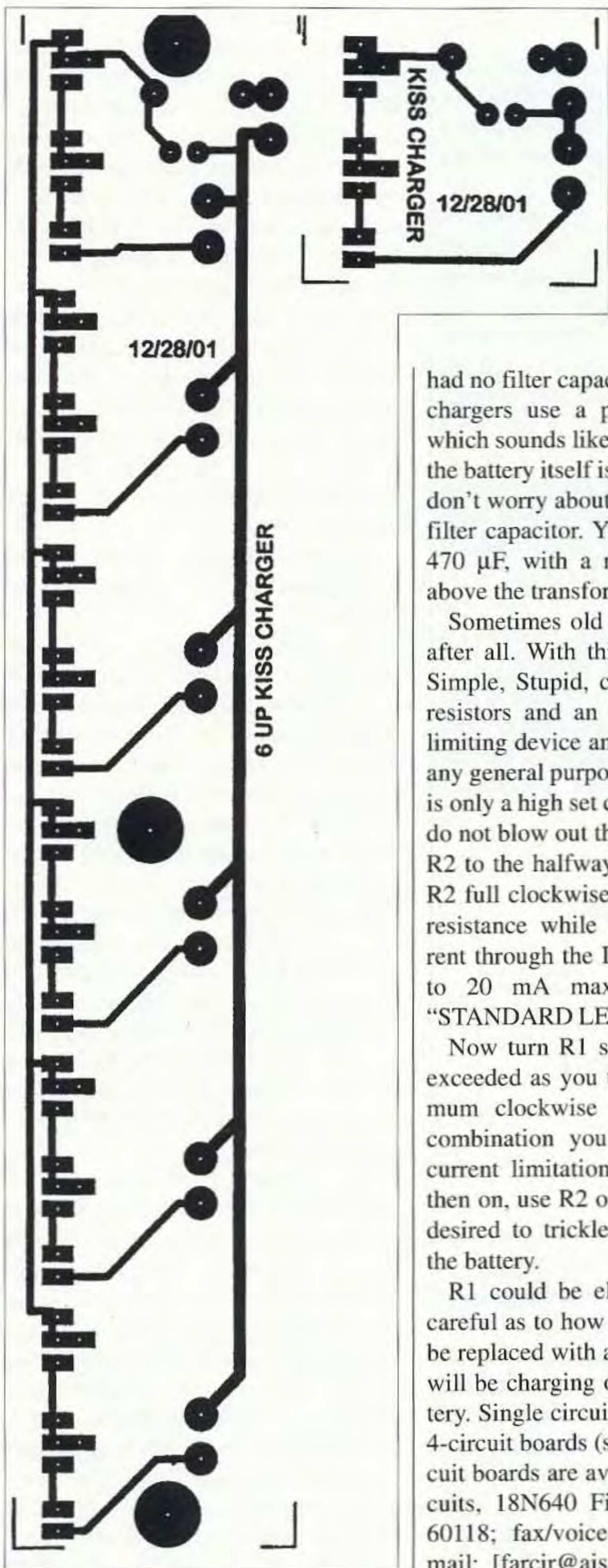

Fig. 4. PC board foil layout, 1-up and 6-up.

wall wart is AC output, install D1 and the filter cap on the PC board.

Remember, the Motorola charger

had no filter capacitor. Most of today's chargers use a pulse charge circuit, which sounds like AC, doesn't it? Well the battery itself is a very good filter so don't worry about installing much of a filter capacitor. You can use 22 μ F to 470 μ F, with a rated voltage that is above the transformer output voltage.

Sometimes old ideas are not so bad after all. With this NEWER, Keep It Simple, Stupid, circuit, we use small resistors and an LED as the current limiting device and an indicator. D1 is any general purpose rectifier diode. R1 is only a high set current limiter so you do not blow out the LED. Turn R1 and R2 to the halfway position. Then turn R2 full clockwise slowly to minimum resistance while monitoring the current through the LED; and the battery to 20 mA maximum if you use "STANDARD LEDs."

Now turn R1 so that 20 mA is not exceeded as you turn R2 to the maximum clockwise position. With this combination you cannot exceed the current limitation of the LED. From then on, use R2 only to set the current desired to trickle charge or maintain the battery.

R1 could be eliminated if you are careful as to how you set R2, or it can be replaced with a fixed resistor if you will be charging only one type of battery. Single circuit boards (see Fig. 2), 4-circuit boards (see Fig. 3), and 6-circuit boards are available from Far Circuits, 18N640 Field Ct., Dundee IL 60118; fax/voice: 847-836-9148; E-mail: [farcir@ais.net]. Or the circuit can be built in about the size of a postage stamp on a simple vector- or prototype board.

Remember, I stated that you could literally charge as many types and

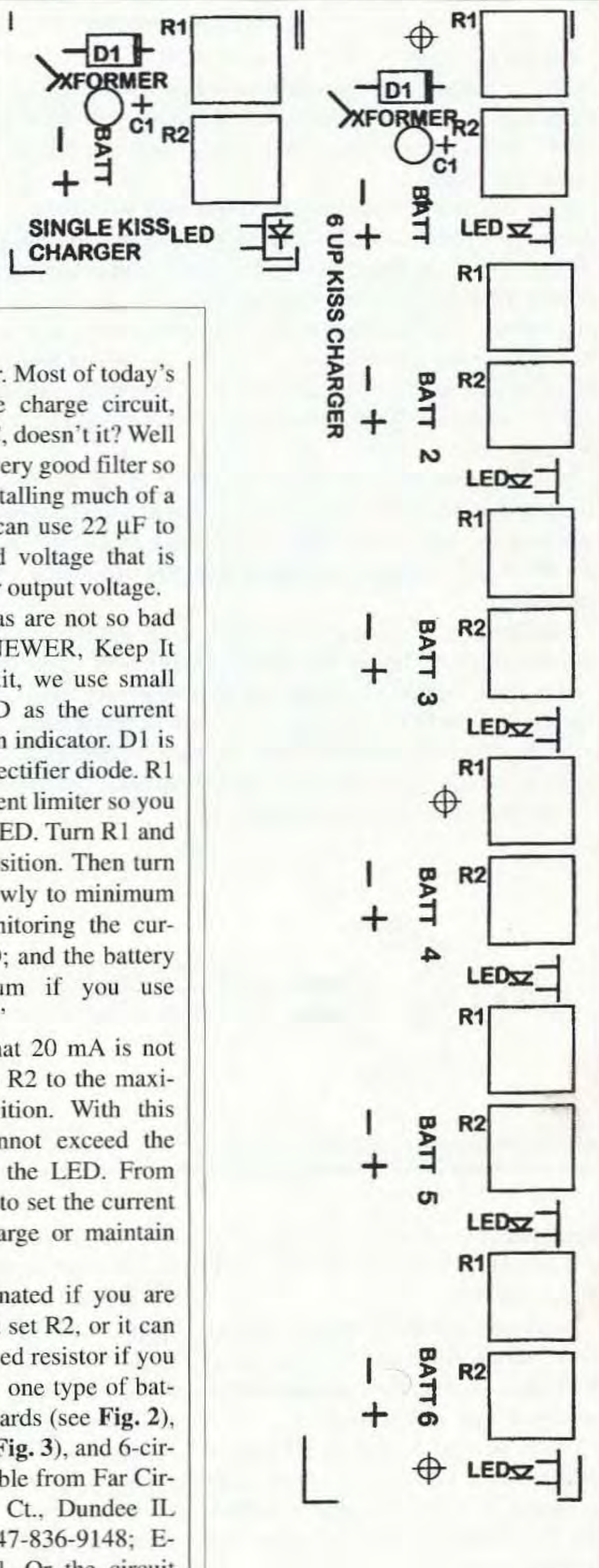

Fig 5. Component placement.

quantities of batteries as your heart desires. With the 4-circuit board you could charge some AAA, AA, C, and
73 *Amateur Radio Today* • January 2003 23

Handy Milliammeter

I think that most of us at one time or another have had the need, and or the desire, to measure the current in a battery-operated device. Many of these devices have a battery holder where the battery or batteries snap down into a "well" or pocket. Getting a multimeter in series with the batteries sometimes can be very trying.

Here is a device that I have used for years with great success. Get a piece of the thinnest double-sided PC board material that you can find — some is made about 0.015 thick. It can be found in ample supply at most hamfests. (If you are buying the K.I.S.S. Charger boards from Far Circuits, they might send a small piece of the thin PC board material for this project, if you ask.) Cut it to about 2–3 inches long and by about 1/4 inch wide. If you make it wider you will not be able to use the same board on some AAA battery devices. Material that thin can be cut easily with a pair of scissors — just don't let the YL catch you using her good pair ...

Next, sharpen one end like a screwdriver blade or chisel. Make the angle as shallow and as sharp as you can; it will make the insertion, as described later, much easier. Next, at the other end solder a short piece of wire to each side of the PC board material, something that you can attach your multimeter to on each side.

I have one with short bare wire leads AND small test lead sockets; that way, I can use alligator clips or just plug the multimeter leads into the sockets.

Have you figured out where we are going with this yet? Just slip the sharpened end of the PC board material between 2 batteries or between a battery and the contact on the device that you are going to measure. This opens up the battery circuit and puts your milliammeter in series so that you can measure the current that your device is drawing.

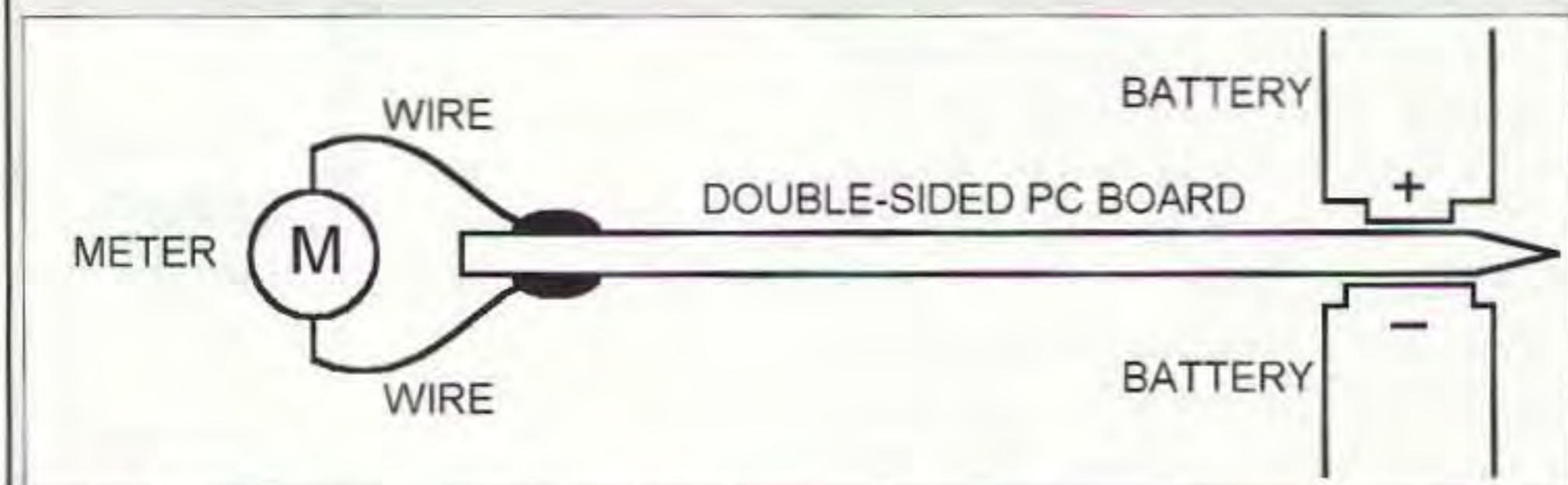

Fig. S1. Milliammeter adapter.

9-volt batteries all at the same time and at different charge rates for each charger circuit.

I use snap in battery holders similar to the Radio Shack part numbers listed in **Table 2**, or you might already have a good junk box with some in it.

I have several 6- and 8-cell battery holders and if I do not have many cells to charge at a time, instead of soldering the charger output wires to the holders, I use alligator clips to hook up the needed number of cells. The individual cell connections are easy to get at in most of the cell holders.

If you have battery packs, such as used in HTs, camcorders, computers,

etc. with no way to attach alligator clips, etc., to them, try this. Take a thin piece of wood with 2 nails driven through in the proper place, fasten the charger leads to them, and lay the battery contacts on the nails. Something a little more universal and easy to configure would be a thin piece of cardboard, with thumb tacks pushed through in the proper places; again, just lay the battery contacts on the sharp end of the tack ... crude but it works, and can be configured for most battery types. The contacts on most batteries are steel, does that light up a bulb in your mind? Try using small magnets with wire leads to the charger. This works just fine.

The circuit is so simple and low cost that almost any number of them can be tied to ONE transformer. The "COMMON LED" has a current limit of about 20 mA. This is enough to trickle charge and maintain all common cells up to full size "C" cells. There are several manufacturers of HIGH-CURRENT LEDs that will handle 50 and 60 mA. They would be ideal for "D" cells and 5-amp lead acid types. Just substitute the high current LED for the regular one on one board for your higher current applications, or you could take a step backward in technology and use the grain-of-wheat-size incandescent bulbs at the proper current rating.

For those among you who like to experiment, here is a new route to pursue ...

For a little more than a year I have been trying something different, but it is a little early to make too much of a definitive statement. We have all read that many chargers today use a pulse charging system that is hard for many of us to duplicate with the surface mount parts that are being used. I have been trying a system using FLASHING LEDs, instead of regular LEDs. First, most flashing LEDs will handle up to 70 mA; this can be a bonus when charging C and D or high-current cells or batteries. Another plus is that you can still use this same PC board; just use the flashing LEDs in place of the regular ones. Now the DOWNSIDE — they cost more.

The current is hard to measure IN THE FIELD, because it is pulsed, and most analog and or digital meters will give false readings. One partial way around measuring the current is to set the current with a regular LED installed, then put in the flasher. This SEEMS to work OK in most cases; some regular LEDs will take 50–70 mA for a short period of time, long enough to set the current properly. One more plus and/or minus is that in "theory" it will take twice as long to charge the battery because of the 50% duty cycle flashing on and off. On the other hand, pulse charging is supposed to take less time to charge.

Continued on page 56

K.I.S.S. Trickle Charger

'continued from page 24

Now you see why I do not have definitive information to offer on this method. All of my research so far seems to lean in the positive direction. So far I have not found any negative aspects.

I would love to hear your comments on this article.

Many thanks are due to Angelo Polvere KA9CSO, Harry Gilling W9IB, John WA9JBT, and Ron Remus WB9PTA, for helping with the editing, proofreading artwork, construction, and photography for this article. 73