

Arduino Based Gesture-Controlled Robot

PRASHANT KUMAR

Presented here is an Arduino based gesture-controlled robot, which is controlled through an accelerometer module using wireless radio frequency (RF) communication.

Circuit and working

In this project, we have used two Arduino UNO boards, one at the transmitter side as shown in Fig. 1 and the other at the receiver side as shown in Fig. 2. The transmitter circuit is attached to the hand and the receiver



circuit is attached to mechanical chassis of the robot.

Hand gestures, as shown in Fig. 3, can control the robot using an accelerometer such as ADXL345 module. By changing the axis of ADXL345, we get corresponding changes in X-axis, Y-axis and Z-axis coordinates. These are sent to Arduino Board2 and, accordingly, control

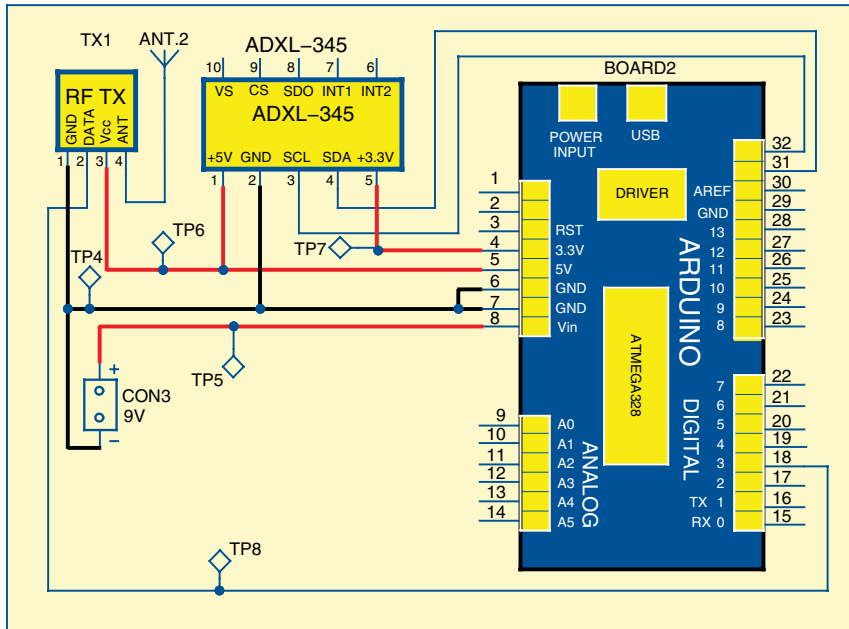

Fig. 1: Transmitter-side circuit

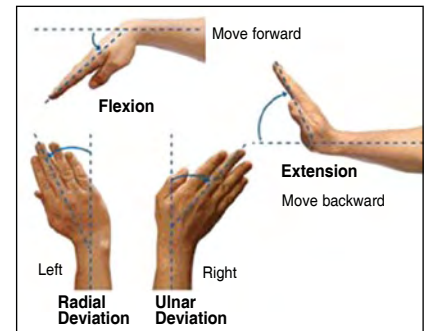

Fig. 3: Various hand gestures

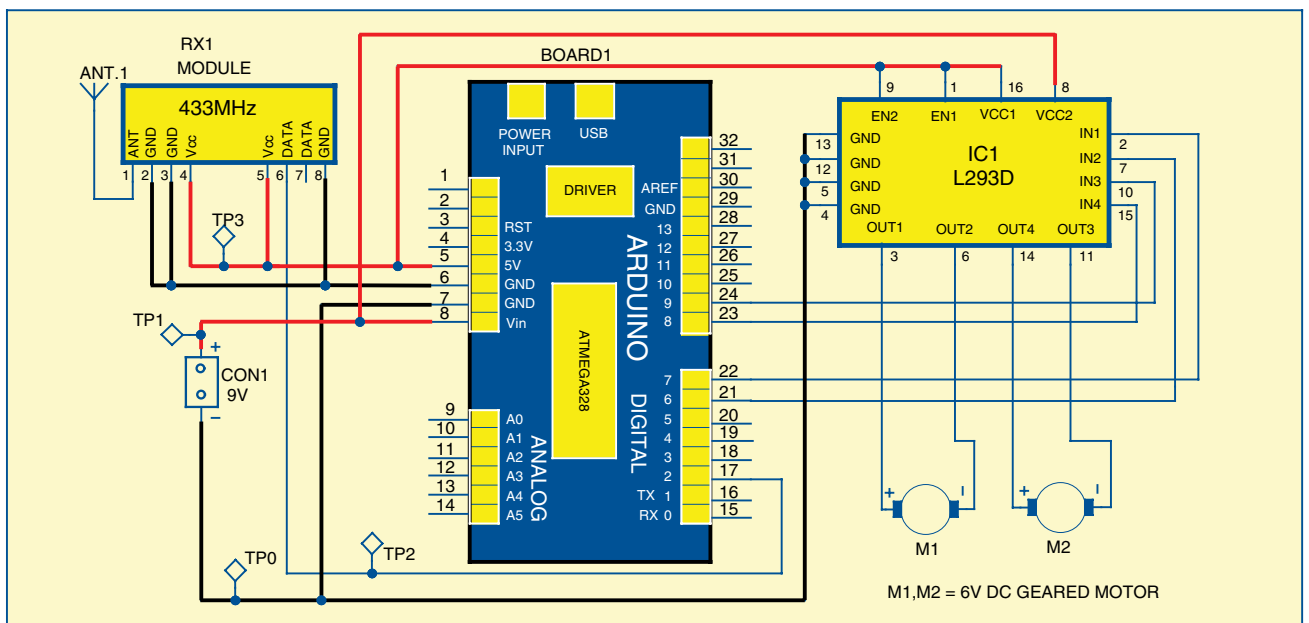

Fig. 2: Receiver-side circuit

Test Points

Test point	Details
TP0, TP4	0V (GND)
TP1, TP5	9V DC
TP2, TP8	Data
TP3, TP6	5V DC
TP7	3.3V DC

command to the robot is sent through the RF transmitter module wirelessly.

These transmitted signals are received at the receiver end through an RF receiver module and transferred to Arduino Board1 at the receiving end, which then drives L293D IC to rotate the motors for robotic movement.

Arduino UNO board. Arduino UNO is an open source electronics prototyping platform based on flexible, easy-to-use hardware and software. Arduino UNO development board is built around ATmega328 chip. It has 14 digital input/output pins [of which six can be used as pulse-width modulation (PWM) outputs], six analogue inputs, a 16MHz ceramic resonator, USB connection, power jack, an ICSP header and reset button. It contains everything for supporting the microcontroller (MCU); simply connect it to a computer with a USB cable or power it with an AC-to-DC adaptor or battery to get started.

ADXL345 module. ADXL345 accelerometer modules are available from various manufacturers. Shapes and sizes of the modules may differ but these all have SDA, SCL, SDO and CS pins for I2C and ISP serial communications. Pin details of a typical ADXL345 module are shown in Fig. 4.

You may also use a module equivalent to ADXL345 such as Keyes-345 accelerometer module. It communicates with Arduino using I2C communication protocol. Here, Arduino UNO board acts as the master device and ADXL345 as the slave device. SDA and SCL pins of ADXL345 should be connected to the SDA pin (pin 31) and SCL pin (pin 32) on Arduino UNO board, respectively.

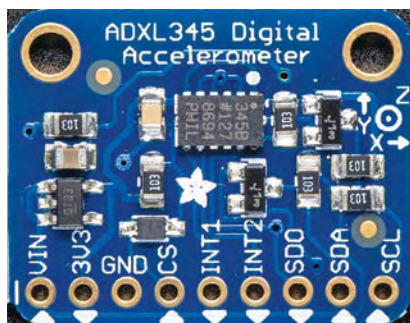

Fig. 4: Pin details of a typical ADXL345 module

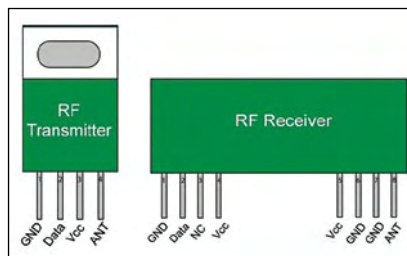

Fig. 5: RF transmitter and receiver modules

Readings of the accelerometer will give the tilt direction of ADXL345 on all three axes (X, Y and Z) by varying the gesture of the hand.

RF module. An RF module is a fast and effective device for wireless communication for shorter ranges. Here, we have used a pair of RF transmitter and receiver modules, operating at 433MHz. A library of Arduino, named VirtualWire.h, is used to sync the RF module with Arduino. Of the eight pins of the RF receiver, only four pins, namely, Antenna, 5V, GND and Data are used here. Connect a single-strand wire to Antenna pin of both transmitter and receiver pins of the RF modules as shown in Fig. 5.

Software program

Program for this robot includes Wire.h header file for I2C communication protocol and VirtualWire.h library of Arduino to sync the RF module with Arduino.

VirtualWire.h is an Arduino library that provides features to send short messages. It allows you to send and receive data bytes and strings easily.

The software has the following functions:



And **WIN** Award!

You can win one thousand rupees plus a certificate from the editor of Electronics For You magazine if you spot and report any factual error in the latest issue of the magazine. Your report will be published in a coming issue of the magazine, giving credit to you.

Though every care is taken in preparation of the content for the magazine, an error can slip in at times. So we invite our learned readers to point out any error that they spot, for the benefit of the other readers.

Rules:

- The error has to be reported before end of the month that is mentioned on cover of the magazine
- The report has to be sent in writing or by email addressed to the Editor, EFY Magazine (editsec@efy.in)
- The error should be of factual nature, in the information published in the magazine, and not a typographical, grammatical or syntax error
- The correct information should also be provided along with the error spotted by you
- In case more than one person reports the same error, the one whose report reaches us the earliest will get the award money
- In case two or more persons jointly report an error, the award money will be divided amongst them
- EFY employees, their family members and friends, and EFY associates and their family members and friends are not eligible
- Decision of the editor will be final in this matter

electronics
FOR YOU

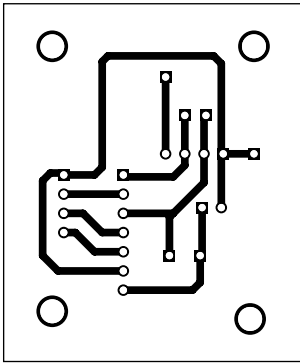

Fig. 6: Actual-size PCB layout of the transmitter circuit

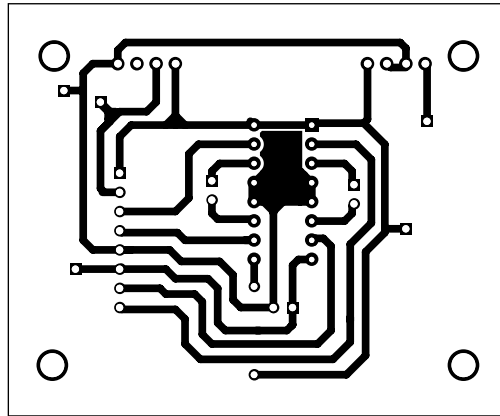

Fig. 8: Actual-size PCB layout of the receiver circuit

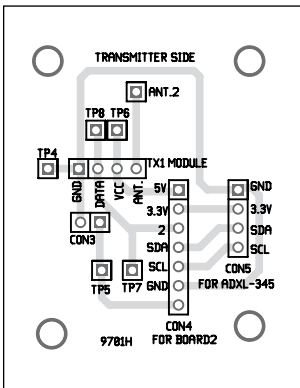

Fig. 7: Component layout of the transmitter circuit

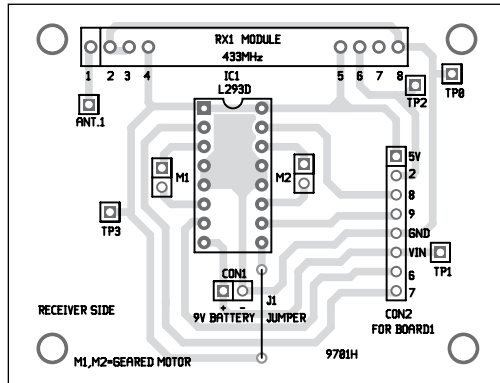

Fig. 9: Component layout of the receiver circuit

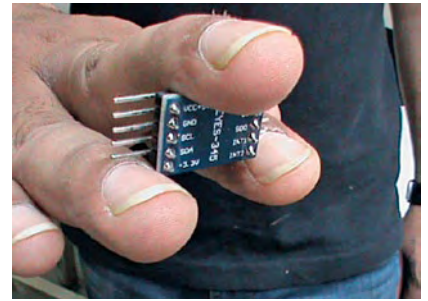

Fig. 10: Attaching the accelerometer module between fingers

PARTS LIST

<i>Semiconductors:</i>	
LCD1	- 16x2 LCD
IC1	- L293D motor driver
BOARD1,	
BOARD2	- Arduino UNO board
TX1	- 433MHz RF transmitter module
RX1	- 433MHz RF receiver module
ADXL345	- Accelerometer module
<i>Miscellaneous:</i>	
M1, M2	- 6V, DC geared motors
CON1, CON3	- 2-pin connector
CON2	- 8-pin connector
CON4	- 7-pin connector
CON5	- 4-pin connector
ANT.1, ANT.2	- 30cm-long single-strand wire antenna
	- USB A-B cable
	- 9V battery (2)

EFY Note

The source codes of this project are included in this month's EFY DVD and are also available for free download at source.efymag.com

void writeTo(int device, byte address, byte val). This function is used to write bytes of data from a particular byte address to the slave device.

void readFrom(int device, byte address, int num, byte buff[]). This function is used to read bytes of data of particular buff sizes from a specific buffer address.

void setup(). This function is used to initialise the baud rate for serial communication and other pins for digital input/output.

void loop(). This function is used to perform the required task of comparing data with the reference set by the user for X, Y and Z axes and perform the task of transmitting data

for forward, backward, left and right movement of the robot.

Construction and testing

An actual-size, single-side PCB layout of the transmitter circuit for the hand-gesture-controlled robot is shown in Fig. 6 and its component layout in Fig. 7. An actual-size, single-side PCB layout of the receiver circuit is shown in Fig. 8 and its component layout in Fig. 9. Connect Board1 to CON2 in the PCB layout (Fig. 9), Board2 to CON4 and ADXL345 to CON5 in the PCB layout (Fig. 7). Pin numbers shown in CON2 and CON4 refer to the digital pins of Arduino boards.

Fit the transmitter circuit in a glove so that it can be used repeatedly. Place ADXL345 below the middle finger such that the pins' side of ADXL345 is facing towards you as shown in Fig. 10. We use the middle finger for attaching ADXL345 because it will get the best average

motion of the movement of the hand.

The rest of the circuit of Arduino and RF transmitter can be fitted near your wrist or on a separate PCB so that it does not disturb hand movements.

On the receiver side of the robot, Arduino UNO board should be connected to L293D IC and the remaining circuit through proper connection of wires. We have used standard 9V batteries to power transmitter and receiver circuits during testing. Use of separate voltage sources for Arduino UNO board and L293D motor driver IC is recommended for better performance. A 30cm-long wire can be attached to antenna pins of both transmitter and receiver modules for better communication. ●



Prashant Kumar is a B.Tech from IIT, Jodhpur. His interests include working with robotics, circuit design and Arduino boards