

IF YOU'RE INTERESTED IN MEDICAL ELECTRONICS, OR just concerned about your family's health, then you should build the Radio-Electronics electrocardiograph. The electrocardiograms (ECG's or EKG's) it will produce can be analyzed by yourself or your doctor. We are not suggesting that you practice medicine using this device, but you should find it interesting and educational in monitoring your health. You will see some of the unique techniques used in medical electronics and you may be surprised to see how similar medical electronic equipment is to most other types of electronic equipment.

The electrocardiograph that we will build produces ECG's that are essentially identical to those produced by commercial machines costing \$10,000 dollars or more. In order to keep our cost to a minimum we use a standard PC as an operator interface and output device. That way you can print out a hard copy of your ECG or just display it on your monitor.

### Biological theory

In order to understand the electronic operation of an electrocardiograph, we need to understand some basic biological principles. As shown in Fig. 1, the heart consists of four chambers which are organized as two pumps—the so-called right and left heart. The right heart collects the blood returning from the body and pumps it to the lungs, while the left heart collects blood from the lungs and pumps it to the body.

Each pump has two parts: the upper chamber known as the atrium and the lower chamber known as the ventricle. The atrium collects blood between cycles and at the appropriate time contracts, filling the lower ventricles. The ventricles then contract and pump blood to the lungs or body.

The heart is controlled by a pulse generator, known as the pacemaker, located in the right atrium, which initiates cardiac action. It is analogous to the clock in a digital system. The pulse it generates is first sent to both atrium which causes them to contract, filling the ventricles. After a delay of approximately 150 milliseconds, the ventricles are then triggered by the same pulse, which causes them to contract. As in a digital system, the timing relationships are quite important and much of the disease associated with the heart is related to timing defects.

Figure 2 shows a typical signal as seen on an ECG. The first pulse, called the "P" wave, is generated by the pacemaker. The next pulse, called the "QRS complex," represents the electrical signal generated by the ventricles contracting. The "T wave" which follows the QRS complex is generated as the muscles of the ventricles relax, or repolarize.

A standard ECG consist of 12 channels; each channel "looks" at the heart from a different electrical axis. The different "views" allow us to interpret the activity of different parts of the heart. The timing relationships between different components of the heart will identify defects in the conduction pathways.

### How ECG's are used

In patients with high blood pressure, the left ventricle will become quite large due to its in-

# ELECTROCARDIOGRAPH

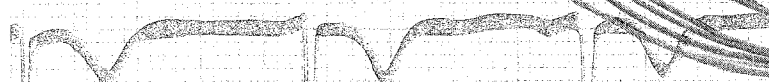
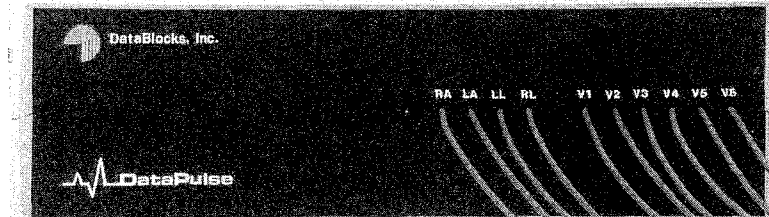
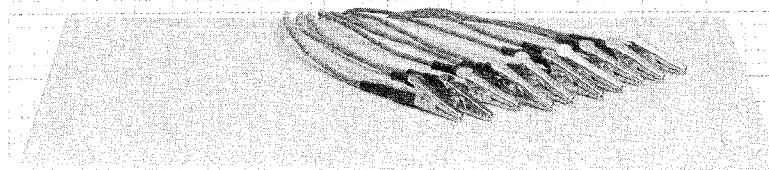
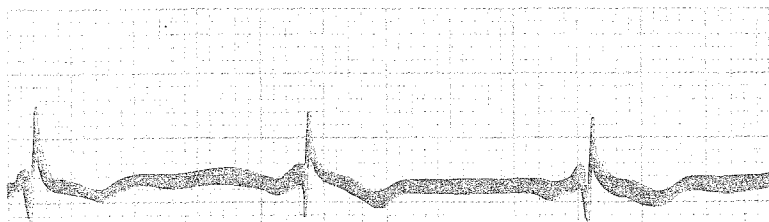

**Keep an eye on your health and learn about medical electronics with the Radio-Electronics electrocardiograph.**

H. EDWARD ROBERTS, M.D.

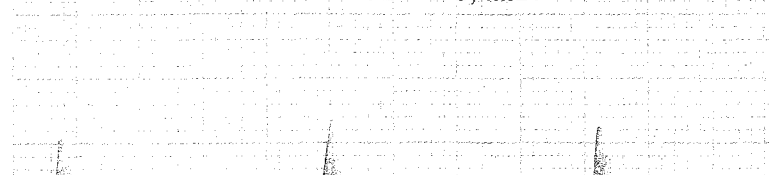

**WARNING!!** This article deals with and involves subject matter and the use of materials and substances that may be hazardous to health and life. Do not attempt to implement or use the information contained herein unless you are experienced and skilled with respect to such subject matter, materials and substances.

Furthermore, the information contained in this article is being provided solely to readers for educational purposes. Nothing contained herein suggests that the monitoring system described herein can be or should be used by the assembler or anyone else in place of or as an adjunct to professional medical treatment or advice. Neither the publisher nor the author make any representations as for the completeness or the accuracy of the information contained herein and disclaim any liability for damages or injuries, whether caused by or arising from the lack of completeness, inaccuracies of the information, misinterpretations of the directions, misapplication of the information or otherwise.

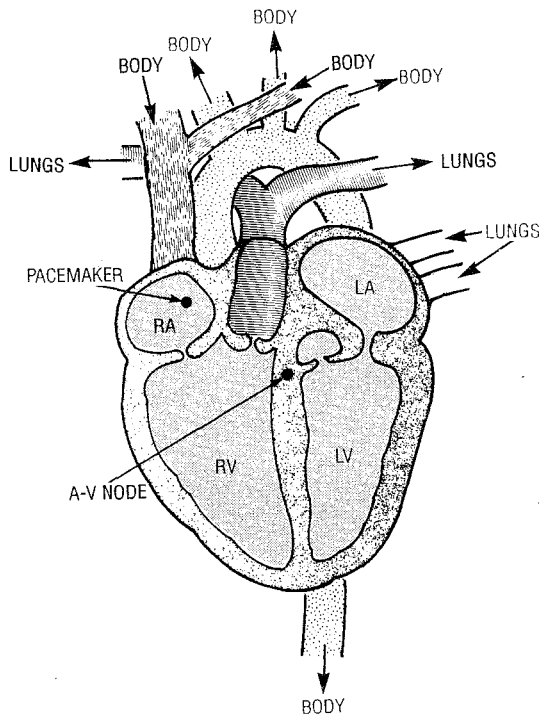

FIG. 1—THE HEART CONSISTS OF FOUR CHAMBERS which are organized as two pumps, known as the right and left heart. The right heart collects the blood returning from the body and pumps it to the lungs, while the left heart collects blood from the lungs and pumps it to the body.

TABLE 1—I/O PORT ADDRESS FUNCTIONS

Port Address	Control Pulse Function
52	Generates Clock for Multiplexer Sequencer
53	Generates Clear for Multiplexer Sequencer
54	Latches ECG Control Signal Byte in IC16
55	Latches Lead Offset Data in IC17

creased work load. That is seen as a significant increase in the amplitude of the QRS complex. Treatment of the high blood pressure will allow the left ventricle to return to normal size, which significantly decreases the chance of a heart attack.

Since the amplitude of the electrical signals in the heart are a function of chemicals in the body, it is possible to predict abnormalities. For example, an elevated potassium level will produce a tall peaked T wave.

If a portion of the ventricle is damaged, a so-called "Q wave" is formed which is simply a negative-going QRS complex. The location of the damage can be determined by noting which leads contain the Q wave. That's how a doctor can tell where you have had a heart attack.

Most normal individuals pro-

duce an extra, or irregular heart beat every now and then, which may occur in the top or bottom of the heart. It is a condition known as arrhythmias. The irregular beats can be quite dangerous if they occur frequently or if they occur during certain intervals in the normal cardiac cycle. Many researchers believe that the most common cause of death in males is due to irregular beats occurring at a time such that they "scramble" the normal electrical timing in the heart—the situation is known as fibrillation.

Special ECG systems, known as Holter monitors, can detect these irregular beats. They are simply ECG's with one or more channels that store each of the 80,000 or so beats in one day. The data from the Holter is then fed into a computer which analyzes it for arrhythmias. Similar

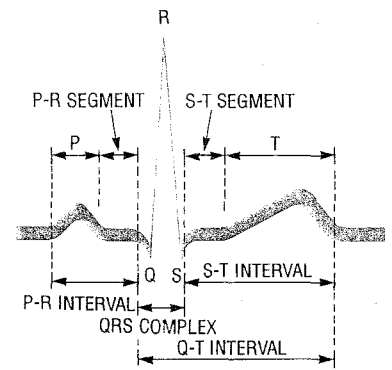

FIG. 2—A TYPICAL SIGNAL as seen on an ECG. The first pulse, called the "P" wave, is generated by the pacemaker. The next pulse, called the "QRS complex," represents the electrical signal generated by the ventricles contracting. The "T wave" which follows the QRS complex is generated as the muscles of the ventricles relax, or repolarize.

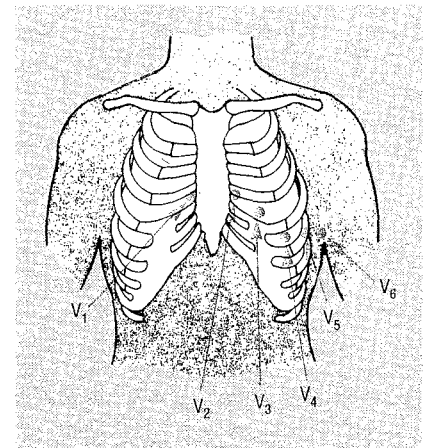

FIG. 3—TEN LEADS ARE CONNECTED to the patient in a 12-channel system: they are right arm, left arm, left leg, and 6 chest leads called the V leads. The right leg is used as a ground and as an input to reduce system noise.

monitoring equipment is used in ambulances and intensive care units for instantaneous analysis of irregular beats. Often this analysis is performed automatically by arrhythmia detectors.

Another area of particular interest in ECG's is the "ST segment." That is the area between the QRS and the T wave. It is very predictive of obstructed arteries before any damage occurs to the heart. Obstruction of an artery will result in a depressed ST segment of the ECG—it will fall below the base line in the affected leads. The exercise cardiogram, or stress test, looks primarily at the ST portion of the ECG to predict if any of the heart's arteries are becoming clogged.

It is possible to become quite

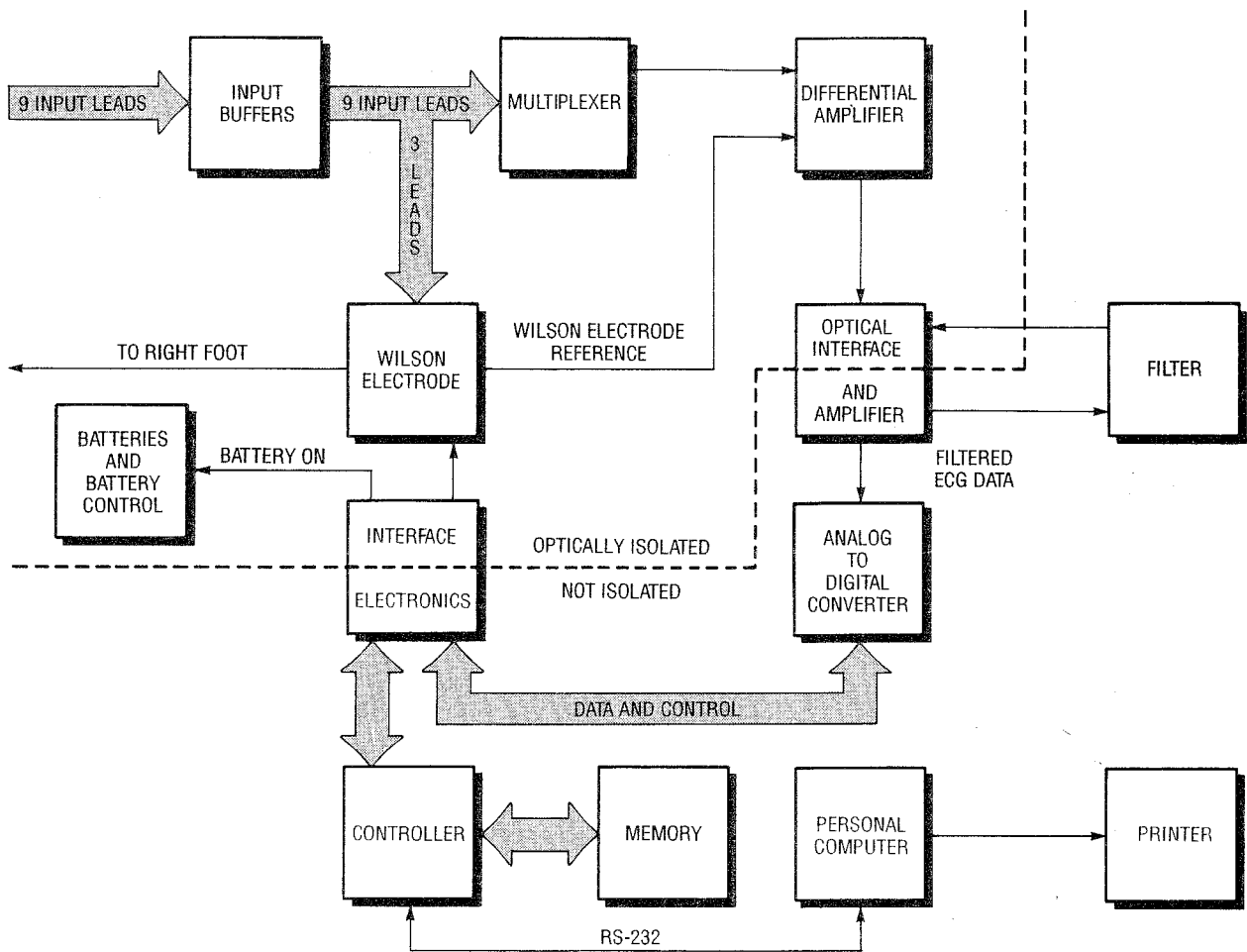

FIG. 4—BLOCK DIAGRAM OF THE COMPLETE ECG SYSTEM. The system logically divides into the front-end electronics and the controller. Data communication between the analog and digital portion of the ECG is accomplished through optical isolators, which helps keep the patient isolated.

All resistors are ¼-watt, 5%, unless otherwise noted.

- R1—10 ohms
- R2, R7—R10—10,000 ohms
- R3—R6, R15, R16—1000 ohms
- R11—7500 ohms
- R12—24,000 ohms
- R13—30,000 ohms
- R14—10,000 ohms × 8, SIP

#### Capacitors

- C1—C22, C25, C26, C28, C29, C33, C34, C42—0.47 μF, ceramic disk
- C23, C24—22 pF, ceramic disk
- C27, C30—0.001 μF, metal film
- C31—220 pF, ceramic disk
- C32—10 μF, 10 volts, electrolytic
- C35, C38, C39—10 μF, 10 volts, tantalum
- C36, C37, C40, C41—1 μF, 10 volts, tantalum

#### Semiconductors

- IC1—Z80 CPU
- IC2—IC5, IC12—74HC245 bus transceiver
- IC6, IC8—Altera EP320 PAL
- IC7—Altera EP600 PAL
- IC9—27C256 EPROM
- IC10, IC11—55257 static RAM
- IC13—74HC688 equality comparator

#### PARTS LIST—CONTROLLER

- IC14—74HC138 1-of-8 decoder
  - IC15—82C52 UART
  - IC16, IC17—74HC573 octal latch
  - IC18—74HC74 dual D flip-flop
  - IC19—MC145406 RS232 transceiver
  - IC20—AD0829 A/D converter
  - IC21, IC22—DAC0830 D/A converter
  - IC23, IC24—NE5532A op-amp
  - IC25—74HC14 hex Schmitt inverter
  - IC26—74HC00 quad NAND gate
  - IC27—PS2501A-2 optoisolator
  - IC28, IC31—not used
  - IC29—ICL7660 DC-DC converter
  - IC30—78L06AC voltage regulator
  - IC32—7805 voltage regulator
  - D1—D4—1N914 diode
  - D5—5.1-volt Zener diode
  - D6—6-volt Zener diode
  - Q1—IRFZ10 N-channel MOSFET
- Other components**
- XTAL1—2.4576 MHz crystal
  - XTAL2—8.00 MHz oscillator
  - S1—SPDT momentary contact switch
  - SO1—DB25 connector

Note: The following items are available from DataBlocks, Inc., Glenwood, GA 30428, (912) 568-7101.

- Design package including sche-

atics, assembly instructions, and checkout- and plot-software design specifications (ECG-DP): \$27.00.

- Front-end PC board, controller PC board, and design package from above (ECG-PC): \$74.00.

- Complete kit of parts, including both PC boards, IC's, sockets, passive components, design package, ECG software, and checkout software (ECG-KIT): \$289.00.

- Lead kit consisting of 50 feet of 29-gauge shielded cable, 10 alligator clips, heat-shrink tubing, and instructions (ECG-LD): \$53.00.

- EPROM containing ECG software, ECG resident portion of checkout software (ECG-PROG): \$45.00.

- Set of four programmed PAL's (ECG-PAL): \$67.00.

- Case as shown with mounting hardware (ECG-CASE): \$29.00

- Package of 100 self-adhesive electrodes (ECG-EL): \$20.00.

Please include \$5.00 shipping and handling for design package and electrodes, \$10.00 shipping and handling for all other products. Georgia residents must add sales tax.

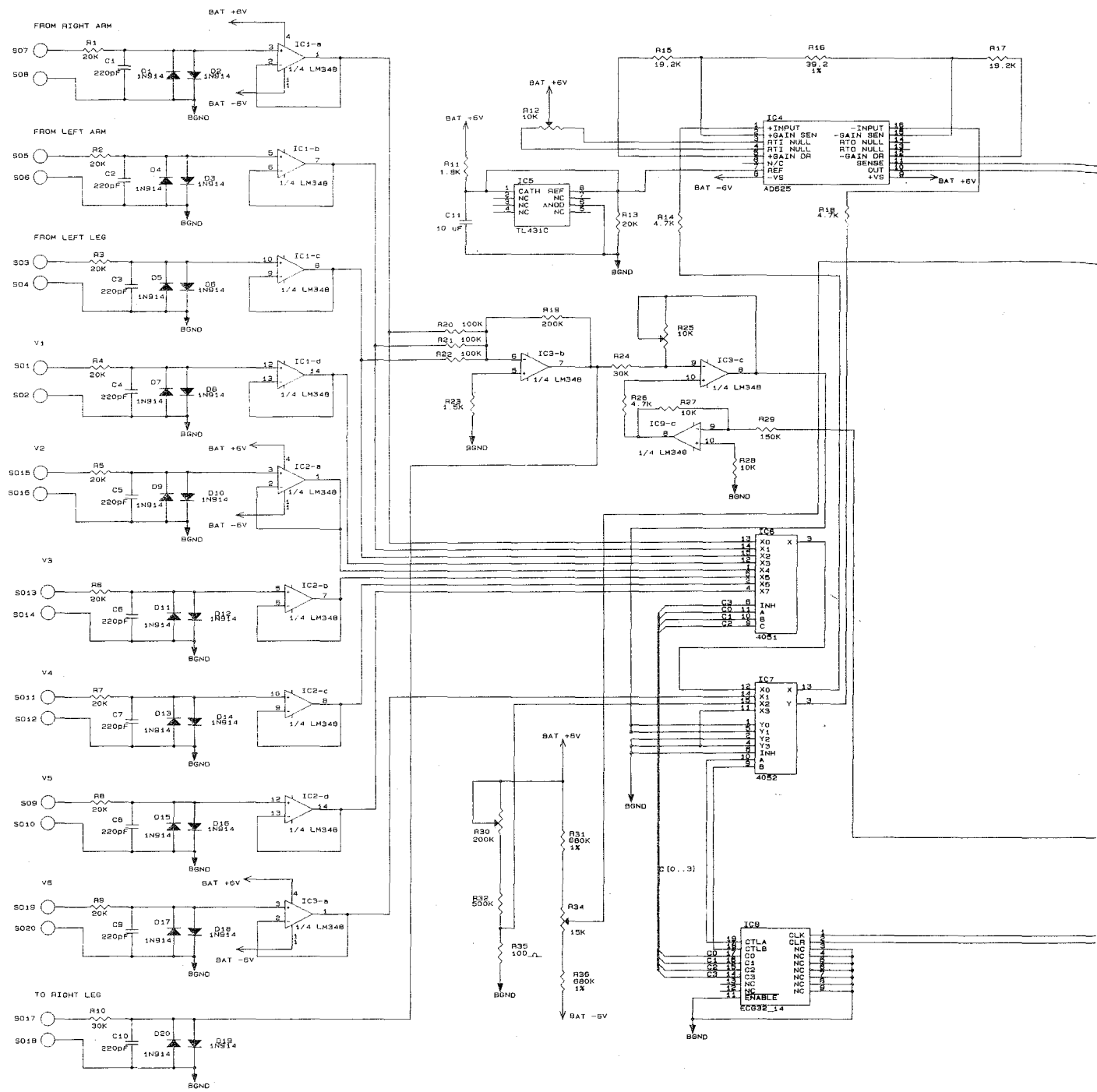
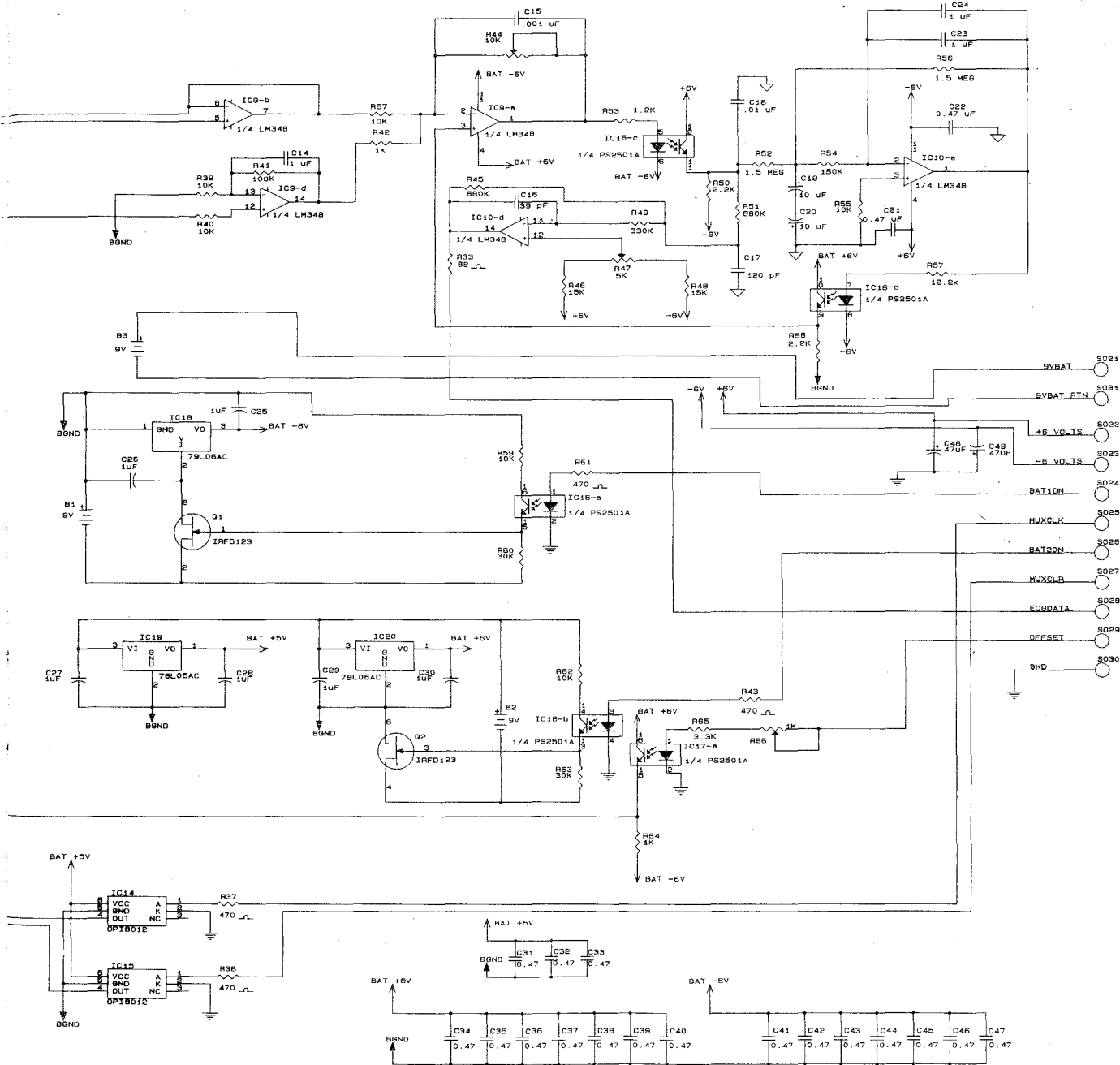

FIG. 5—THE FRONT-END ELECTRONICS takes in the signals from the 9 input leads located on the patient. The small signal from each of the leads is fed into the quad op amps IC1, IC2, and IC3-a.



## PARTS LIST—FRONT-END

All resistors are ¼-watt, 5%, unless otherwise noted.

R1—R9, R13—20,000 ohms  
 R10, R24, R60, R63—30,000 ohms  
 R11—1800 ohms  
 R12, R25, R44—10,000 ohms, potentiometer  
 R14, R18, R26—4700 ohms  
 R15, R17—19,200 ohms  
 R16—39.2 ohms, 1%  
 R19—200,000 ohms  
 R20—R22, R41—100,000 ohms  
 R23—1500 ohms  
 R27—910 ohms  
 R28, R39, R40, R55, R59, R62, R67—10,000 ohms  
 R29, R46, R48—15,000 ohms  
 R30—200,000 ohms, potentiometer  
 R31, R36—680,000 ohms, 1%  
 R32—500,000 ohms  
 R33—68 ohms  
 R34—15,000 ohms, potentiometer  
 R35—100 ohms  
 R37, R38, R43, R61—470 ohms  
 R42, R64—1000 ohms  
 R45, R51—680,000 ohms  
 R47—5000 ohms, potentiometer  
 R49—330,000 ohms  
 R50, R58—2200 ohms  
 R52, R56—1.5 megohm  
 R53—150 ohms  
 R54—150,000 ohms  
 R57—12,200 ohms  
 R65—3300 ohms  
 R66—1000 ohms, potentiometer

### Capacitors

C1—C10—220 pF, 1000 volts, ceramic disk  
 C11, C19, C20—10 µF, tantalum  
 C12, C13—not used  
 C14, C23, C24—1 µF, ceramic  
 C15—0.001 µF, metal film  
 C16—39 pF, ceramic disk  
 C17—120 pF, ceramic disk  
 C18—0.01 µF, metal film  
 C21, C22, C31—C47—0.47 µF, ceramic disk  
 C25—C30—1 µF, tantalum  
 C48, C49—47 µF, 16 volts, electrolytic

### Semiconductors

IC1—IC3, IC9, IC10—LM348 op-amp  
 IC4—AD625 instrumentation amplifier  
 IC5—TL431C precision voltage reference  
 IC6—4051 analog switch  
 IC7—4052 analog switch  
 IC8—Altera EP320 PAL  
 IC14, IC15—OP18012 optoisolator  
 IC16, IC17—PS2501A optoisolator  
 IC18, IC20—78L06AC voltage regulator  
 IC19—78L05AC voltage regulator  
 D1—D20—1N914 diode  
 Q1, Q2—IRFD123 N-channel HEXFET

### Other components

B1—B3—9-volt battery

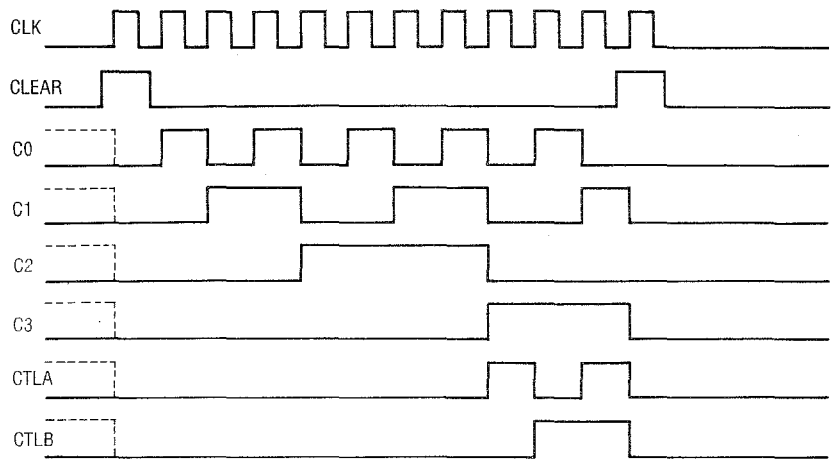

FIG. 6—PAL IC8 SEQUENCES THE MULTIPLEXER ADDRESS LINES so that each input signal is sequentially passed to the multiplexer output for processing. This timing diagram shows the relationships between the PAL's input, output, and control signals.

ticated text written by Marriott is entitled *Practical Electrocardiography*. Sources for these texts are listed in the Sources Box of this article.

### Biological interface

The patient is connected to the electrocardiogram via 3–12 leads in a typical system. The 3-lead systems are used when only the cardiac rhythm is to be studied—in an ambulance, monitoring an athlete, in an intensive care unit, etc. If a detailed analysis of the heart is required, a 12-channel system is normally used. The system that we will build will generate a full 12-channel read out.

Ten leads are connected to the patient in a 12-channel system: they are right arm, left arm, left leg, and 6 chest leads called the V leads (see Fig. 3). The right leg is used as a ground and as an input to reduce system noise.

You might well ask how we get a 12-channel system only using 9 active leads. That is accomplished by combining different leads together. For example, lead "aVR" is equal to the voltage at the right arm minus the sum of the voltages at the left leg and left arm. Table 1 shows how the signals are combined. Our system will collect the data in each lead, digitize them, and then digitally combine the signals within the host computer. More on this later.

A typical QRS will have a peak amplitude of 1 to 2 millivolts. That may mix with noise (60-Hz hum, for example) with much higher amplitudes. The problem,

then, is to distinguish the cardiac signal from the unwanted signal. That is accomplished in biological instrumentation in much the same way as industrial instrumentation: by the use of differential amplifiers. These circuits can attenuate the unwanted signal by 100 dB or more.

The electrode that connects the ECG to the patient must make a low-impedance connection between the system and the patient's skin. That is typically accomplished by the use of disposable silver electrodes, which we will use in our system. The electrodes are made of a silver-chloride gel that provides low impedance and a minimum amount of electrical noise with the skin.

One of the fundamental principles that the medicine is based on is from the Hypocrites Oath, "do no harm." That means under no circumstances should there ever be a possibility of doing any harm using medical instrumentation. In the case of an ECG, the main concern would be the shock potential through the electrodes. In our system we optically isolate the patient from the rest of the electronics. Therefore, even if all the safeguards in the computer's power supply were to fail, the patient would still be protected from shock.

One other concern is to prevent the patient from doing harm to our equipment. In our ECG we provide a resistor-diode network on each lead which prevents a high voltage from entering the

skilled at reading the ECG without being a medical expert, and there are a number of texts on the subject that you will find interesting. In particular, try Duben's *Rapid Interpretation of EKG's*—with it, you can become fairly knowledgeable of ECG's in a matter of a few hours. A more sophis-

ADDRESS				CONTROL		MULTIPLEXER STATE								
FROM PAL				FROM PAL		IC 6		IC 7						
C3	C2	C1	C0	CTLB	CTLA	IN	→	OUT	IN	→	OUT			
0	0	0	0	0	0	X0	→	X	X0	→	X	Y0	→	Y
0	0	0	1	0	0	X1	→	X	X0	→	X	Y0	→	Y
0	0	1	0	0	0	X2	→	X	X0	→	X	Y0	→	Y
0	0	1	1	0	0	X3	→	X	X0	→	X	Y0	→	Y
0	1	0	0	0	0	X4	→	X	X0	→	X	Y0	→	Y
0	1	0	1	0	0	X5	→	X	X0	→	X	Y0	→	Y
0	1	1	0	0	0	X6	→	X	X0	→	X	Y0	→	Y
0	1	1	1	0	0	X7	→	X	X0	→	X	Y0	→	Y
1	0	0	0	0	1	Z			X1	→	X	Y1	→	Y
1	0	0	1	1	0	Z			X2	→	X	Y2	→	Y
1	0	1	0	1	1	Z			X3	→	X	Y3	→	Y

NOTE: Z = OUTPUT IN HIGH IMPEDANCE STATE

FIG. 7—MULTIPLEXER TRUTH TABLE shows how the signals from the PAL are used to control the sequencing of the input signals to the input of the instrumentation amplifier.

front-end amplifiers. An example where this might be significant would be in the case where a patient is "shocked," or defibrillated, after a cardiac arrest. In that case up to 400 volts could appear across the electrodes coming from the patient.

Now that we have a basic understanding of the underlying biological principles associated with the ECG, let's look at some of the technical details of the machine which we will construct. Then let's build one!

### System Theory of Operation

A block diagram of the complete ECG system is shown in Fig. 4. The system can be divided into the front-end electronics and the controller. The analog portion attaches to the patient with 10 lead wires; 9 input leads, and 1 output, or reference lead. The analog portion of the ECG is powered by two 9-volt batteries to isolate the patient from any potentially dangerous power circuitry. In addition, data communication between the analog and digital portion of the ECG is accomplished through optical isolators, which also helps keep the patient isolated.

The controller section of the system contains a Z-80 based computer with 32K of RAM and 32K of EPROM. The controller section of the ECG also contains the analog-to-digital (A/D) conversion circuitry to convert the patient's analog ECG signals to the digital data required for computer processing. In addition, this section generates control signals to sequence the A/D conversion, compensate for input channel offset, and control the

input-lead multiplexer.

Notice that we have included a personal computer and printer in the diagram. Although not a part of this construction article, they are an integral part of the system since they provide the display for the ECG traces.

### Front-end electronics

As previously discussed, the 12-trace ECG is derived from 9 input leads located on the patient. The small (approximately 1 millivolt) signal from each of the leads is fed into the quad op-amps IC1, IC2, and IC3-a, as shown in the schematic of Fig. 5.

The op-amps are configured as non-inverting, unity-gain amplifiers. They provide a very high input impedance that prevents the signals from the body electrodes from being loaded down. Notice also that the input to each amplifier circuit is shunted to ground by a 220-pF capacitor (C1-C10) and two diodes (D1-D20) in parallel. Those components are used to protect the input of the amplifier from the high voltages present during cardiac defibrillation, and to provide patient protection in the unlikely event that high voltage should feed back through the amplifier.

The output of the three limb leads from IC1-a, IC1-b and IC1-c are summed into op-amp IC3-b, inverted, and fed back to the patient through the 10th lead which is attached to the patient's right leg. The composite signal from the three limb leads is called the Wilson Electrode. The Wilson Electrode signal significantly reduces the common-mode noise in the system, since unwanted signals common to the three limb

leads are fed back to the patient 180 degrees out of phase with the original noise. The signal from the Wilson Electrode is again inverted in op-amp IC3-c and routed to the multiplexer to eventually form the reference against which the nine input signals are compared.

The multiplexer is made up of two integrated circuits, IC6 and IC7, in conjunction with the multiplexer-controller IC8. Analog-switch IC6 has 8 inputs (X0-X7). One of the eight inputs is connected through a very-low-impedance path to the output (X) according to the 3-bit address appearing on the control inputs C0-C2. For example, X0 is connected to X when the control address is 000, X1 is connected to the output when the control address is 001, and so on. The additional control address C3, is an inhibit which, when high, causes the output X to be a high impedance, effectively turning off the eight input signals to the multiplexer chip. The output of IC6 is routed to one of the inputs to IC7.

Another analog switch, IC7, has 2 outputs and 4 X-Y input pairs (X0-X3 and Y0-Y3). The X0 input is the output from IC6. The corresponding input Y0 comes from the Wilson Electrode, IC3-c. The signal from IC3-a (input 9) is the input to X1. The Wilson Electrode signal is also paired with input 9 on Y1. In addition to the the nine signal inputs from the patient, a 1-mV test signal and a ground input are routed to the X2 and X3 inputs respectively. Ground is the Y2 input for the corresponding 1-mV signal pair as well as for the X3 ground input on Y3.

Two address lines, CTLA and CTLB control which input pair is switched to the outputs. That is, when the control address is 0, inputs X0 and Y0 are switched to outputs X and Y respectively. These control lines as well as the control signals for IC6 are derived from the outputs of IC8.

IC8 is a programmable array logic (PAL) IC which sequences the multiplexer address lines so that each input signal is sequentially passed to the multiplexer output for processing. The PAL is programmed to advance the address on control lines C0 through



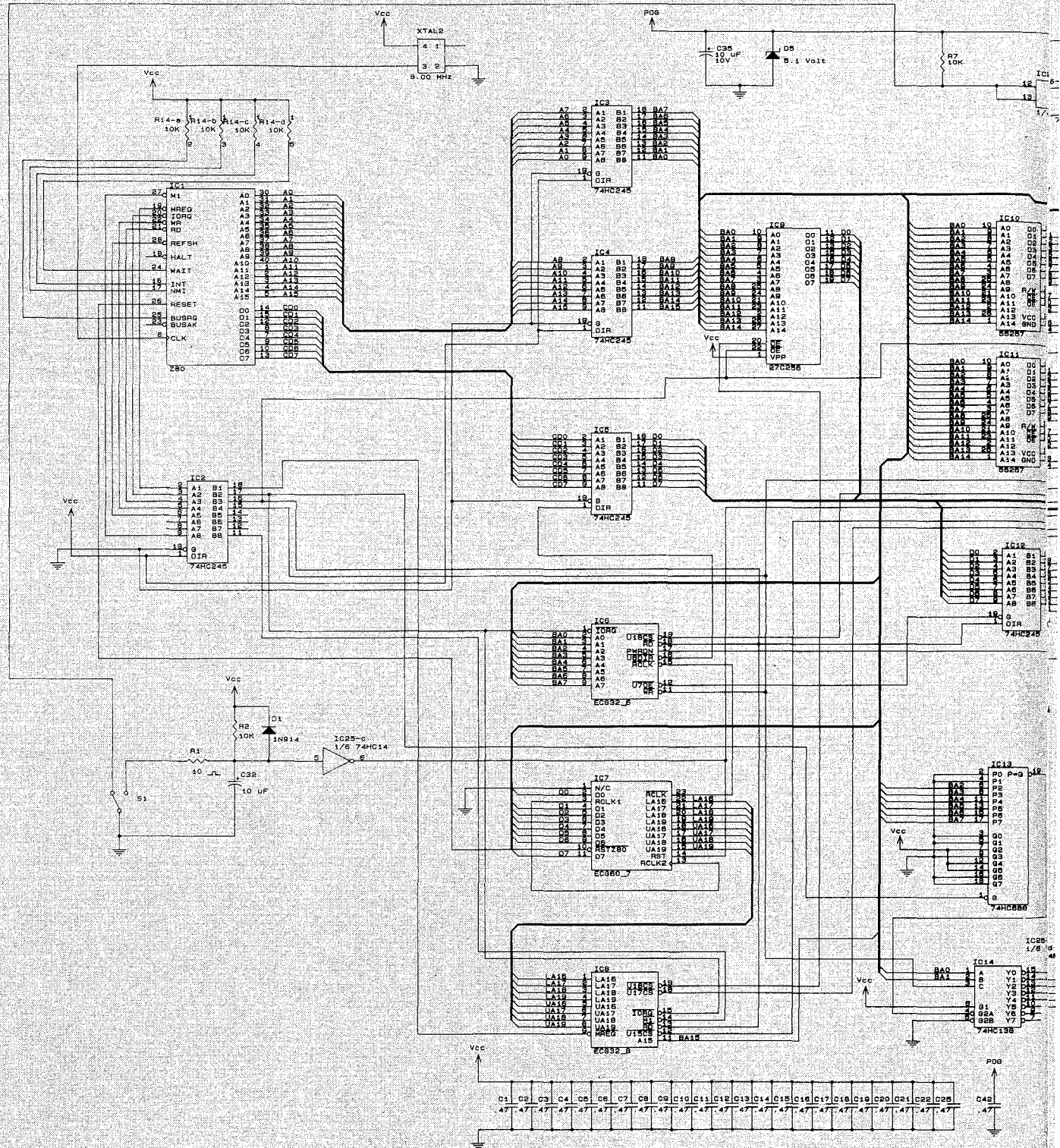
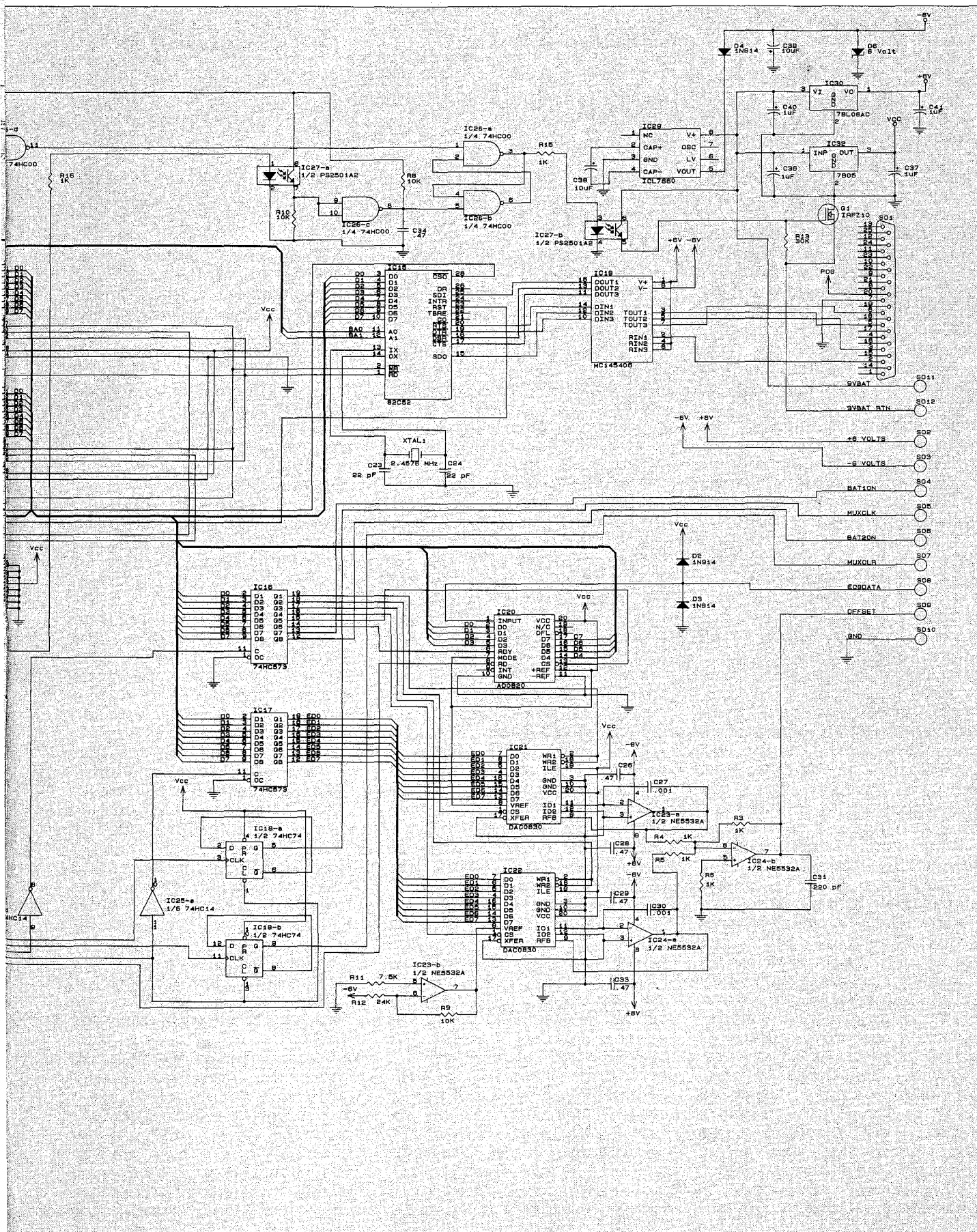

FIG. 8—THE CONTROLLER CONTAINS A Z80-BASED COMPUTER and a digital control section which combine to provide all the sequencing, timing, and control signals for the ECG.





C3 one count each time a pulse is received on the clock input. Additionally, a decode function is programmed in the PAL to control the state of the control lines CTLA and CTLB and, hence, which signal pairs from the multiplexer are fed to the differential inputs of the instrumentation amplifier. The PAL timing diagram in Fig. 6 shows the timing relationships of the input, output, and control signals from the PAL. The multiplexer truth table in Fig. 7 shows how the signals from the PAL are used to control the sequencing of the input signals to the input of the instrumentation amplifier.

The instrumentation amplifier (IC4 and IC9-b back in Fig. 5) is one of the key signal-processing elements in the ECG design. It is a differential amplifier so its output is equal to the difference between its two inputs multiplied by a gain. In this application, the gain is approximately 1000.

The amplifier also has an input offset adjustment, R12, to compensate for minute differences in the input voltages, as well as an output offset capability at pin 7. In this design, the output offset at pin 7 is biased by IC5, a precision voltage reference, to a constant voltage near 2.5 volts. When the difference between the inputs of the instrumentation amplifier is zero, the output will be 2.5 volts. As the differential input voltage changes from zero, the output of the amplifier will change from 2.5 volts by an amount equal to the input difference times the gain.

The final stage in the analog signal path is the isolation circuitry to the A/D converter. It consists of IC9-a, IC16-c, and IC10-d. As the voltage into IC9-a changes, the current through the LED portion of optoisolator IC16-c changes, which modulates the base of the light-sensitive transistor in the optoisolator. That causes the collector current to change, developing a voltage change across the emitter resistor. That voltage follows the original voltage signal at the input of IC9-a with a 180-degree phase difference. To correct the phase reversal and to compensate for bias and gain errors, the signal is fed through amplifier IC10-d prior to going to the con-

TABLE 2—CONTROL SIGNAL DEFINITION

Signal	IC16 Output							
	Q8	Q7	Q6	Q5	Q4	Q3	Q2	Q1
Batteries On	1	1	X	X	X	X	X	X
IC21WR	X	X	X	X	X	X	X	0
IC21CS	X	X	X	X	X	X	0	X
IC22WR	X	X	X	X	X	0	X	X
IC22CS	X	X	X	X	0	X	X	X
IC20CS	X	X	X	0	X	X	X	X
IC20RD	X	X	0	X	X	X	X	X

troller board for A/D conversion. In addition to its gain function, IC1-d is also an active low-pass filter, with a cutoff frequency of about 100 Hz.

A high pass filter is also implemented in the final stage by feeding the ECG signal from the emitter of IC16-c through an active low-pass filter consisting of IC10-a and its associated components. The cutoff frequency for the low-pass filter is about 0.1 Hz, and the output is fed back through IC16-d to the positive input of IC9-a where it is used to cancel frequency components of the original signal below 0.1 Hz. As a result, the frequency components of the ECG signal are limited to a band between 0.1 Hz and 100 Hz.

### Controller operation

The controller contains a Z80-based computer and a digital control section which combine to provide all the sequencing, timing, and control signals for the ECG (see Fig. 8). The Z80 microprocessor (IC1) is clocked by an 8-MHz oscillator, XTAL2. Octal bus transceivers IC2–IC5 buffer the microprocessor control, address, and data buses, and, in the case of IC5, provide bi-directional capability on the data bus. Programmable logic devices (PLD's) IC6, IC7, and IC8 generate various bus-control and chip-select signals to select the appropriate memory and I/O chips. The 32K × 8 EPROM (IC9) stores the CPU operating system and the ECG control program. Two 32K × 8 static RAM's, IC10 and IC11, provide the CPU with 64K of RAM. Communication with the outside world is provided through a universal asynchronous receiver/transmitter (UART), IC15, and its associated line transceiver IC19.

Power for most of the circuitry on the controller board is pro-

vided by a 9-volt battery (B1) located on the front-end board. To extend battery life, the system is powered only during the time required for a single ECG, with each ECG sequence initiated by depressing the reset switch. That is accomplished by powering the start-up circuitry from the RS-232 port on the PC.  $V_{CC}$  for the power-on latch, IC26, is provided by the 5-volt Zener-diode regulator, D5.

When the reset switch is depressed, the power-on latch changes state, turning Q1 on and completing the return path for B1. Power for the controller board is provided by the 5-volt regulator, IC32. A +6-volt supply for the analog circuits on the controller board is provided by IC30. The -6-volt supply for the analog circuitry is provided by IC29, a DC-DC converter. The two 6-volt supplies are also used to power portions of the front-end that don't require patient isolation.

The remaining IC's on the controller board are used to generate the control signals and to digitize the ECG data from the nine patient leads. Components IC13 and IC14 decode I/O instructions from the controller to produce control pulses that sequence the acquisition of the ECG data. Table 1 lists the control pulse generated by each I/O port address.

Each time I/O port 52 is addressed, the resulting pulse clocks IC18-a, a D-type flip-flop wired to divide by two. Two outputs to the I/O port produce a single pulse at the output of IC18-a. The pulse is passed to the clock input of IC8 on the front-end board through IC14, an optoisolator also on the front-end board. In a similar manner, a CLEAR pulse is developed at the CLEAR input to IC8 on the front-end board when the controller

*continued on page 46*

# The World's Most Popular Probe

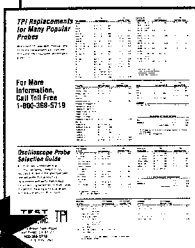
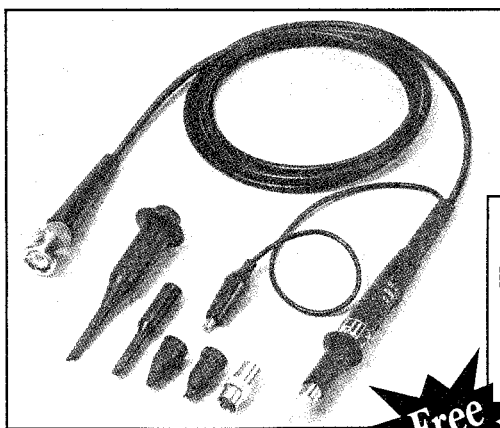

**Free**

Free probe guide shows economical replacements for Tektronix, H-P, Philips and all others

Model SP100  
100 MHz Switchable 1x-10x .... **\$45**

**More SP100 Probes Have Been Sold Worldwide Than Any Other Probe Ever Made**

- **Universal**  
For Tektronix, Hewlett Packard, Philips, Leader, B&K, Kikusui, Hitachi, Beckman and other oscilloscopes
- **Economical**  
Substantial savings compared to OEM probes
- **10 day return policy**  
Guaranteed performance and quality

**TEST  
PROBES, INC.**



9178 Brown Deer Road, San Diego, CA 92121  
Toll Free 1-800-368-5719

CIRCLE 123 ON FREE INFORMATION CARD

## LEARN VCR

**CLEANING/MAINTENANCE/REPAIR**  
EARN UP TO \$1000 A WEEK, WORKING PART TIME FROM YOUR OWN HOME!



**EARN UP TO \$60 AN HOUR AND MORE!**

### THE MONEY MAKING OPPORTUNITY OF THE 1990'S

IF you are able to work with common small hand tools, and are familiar with basic electronics (i.e. able to use voltmeter, understand DC electronics), . . . IF you possess average mechanical ability, and have a VCR on which to practice and learn. . . . then we can teach **YOU** VCR maintenance and repair!

**FACT:** up to 90% of ALL VCR malfunctions are due to simple MECHANICAL or ELECTRO-MECHANICAL breakdowns!  
**FACT:** over 77 million VCRs in use today nationwide! Average VCR needs service or repair every 12 to 18 months!

Viejo's **400 PAGE TRAINING MANUAL** (over 500 photos and illustrations) and **AWARD-WINNING VIDEO TRAINING TAPE** reveals the **SECRETS** of VCR maintenance and repair—"real world" information that is **NOT** available elsewhere!

Also includes all the info you'll need regarding the **BUSINESS-SIDE** of running a successful service operation!

**FREE INFORMATION**  
**CALL TOLL-FREE 1-800-537-0589**

Or write to: Viejo Publications Inc.  
5329 Fountain Ave.  
Los Angeles, CA 90029 Dept. RE

CIRCLE 187 ON FREE INFORMATION CARD

## SUPER LONG PLAY TAPE RECORDERS

12 Hour Model —  
USES 120 TAPE  
**\$119.00\***

Modified Panasonic Slimline, high quality AC-DC provide 6 continuous hours of quality recording & playback on each side of cassette for 12 hours total. Includes • Voice level control • Digital counter, etc. TDK - 120 Cassette Furnished.

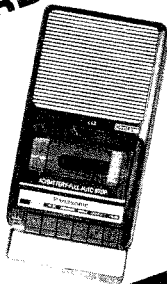

### PHONE RECORDING ADAPTER

Records calls automatically. All Solid state connects to your telephone jack and tape recorder. Starts recording when phone is lifted. Stops when you hang up. **\$28.50\***



### VOX VOICE ACTIVATED CONTROL SWITCH

Solid state. Self contained. Adjustable sensitivity. Voices or other sounds automatically activate and control recorder. Uses either recorder or remote mike. **\$28.50\***



\* Add for ship. & handling. Phone Adapter & Vox \$2.00 each. Recorders \$5.00 each. Calif. Res. add tax. Mail order, VISA, M/C, COD's OK. Money Back Guarantee. Quantity discounts available. Dealer Inquiries invited. Free data.  
**AMC SALES INC.** Dept. A 9335 Luber Street  
Box 928, Downey, CA 90241  
Phones (213) 869-8519 1-800-925-2488  
FAX (213) 923-1478  
Mon-Fri 8-5 PAC. TIME

CIRCLE 108 ON FREE INFORMATION CARD

**ECC**

*continued from page 40*

addresses I/O port 53. These two pulses control the operation of the ECG signal multiplexer. The other two pulses produced at IC14 when the controller addresses I/O ports 54 and 55 are used to latch data into octal latches IC16 and IC17.

Data latch IC17 stores data for the D/A converters IC21 and IC22. Latch IC16 is used to derive additional control signals.

Table 2 shows that to turn both batteries on and to place the other control signals in an inactive state, all output bits of IC16 must be a 1. To achieve that, the CPU must output 255 to I/O port 54. To subsequently activate, or lower, any of the control bits without disturbing the other bits or turning off the battery power, all bits must be high except for the one corresponding to the activated control signal. After the appropriate bits in IC24 have been activated, the CPU must return them to their inactive state by sending 255 to I/O port 54. The same logic applies to the other signals in Table 2.

To see how this all works together in the circuit, let's assume we need to turn on both the positive and negative battery-powered supplies on the front-end board, and write a 127 to IC21 on the controller board. First, the CPU outputs a 255 to I/O port 54. That places a "1" at all outputs of IC16. The "1" at Q8 of IC16 produces a current flow in the LED of optoisolator IC16-a, causing current to flow through its associated transistor. The ensuing voltage drop across R60 turns FET Q1 on, completing the battery input circuit to the -6-volt regulator, IC11. The negative supply is now on. The positive supplies are turned on by the "1" on Q7 of IC16.

Now the CPU must place our arbitrarily chosen value, 127, into the octal latch, IC17, on the controller board. As shown in Table 1, that is accomplished by writing 127 to I/O port 55. Once the correct number is in the latch, the CPU must write it to the D/A converter. Notice that the outputs of the octal latch, IC17,

*continued on page 88*

# CABLE TV EQUIPMENT

Converters, Remote Controls, Descramblers, CD Players.

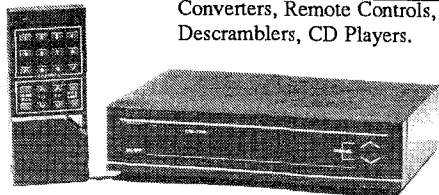

**JERROLD-OAK-SCIENTIFIC ATLANTA-HAMLIN ZENITH MANY MORE CALL TODAY!**

- ✓ Only quality products sold
- ✓ Easy to use
- ✓ Satisfaction guaranteed
- ✓ Knowledgeable sales staff
- ✓ Most orders shipped within 24 hours

**CALL FOR YOUR FREE CATALOG**

**MC 1-800-228-7404 VISA**

**MAKE THE CONNECTION**

**WITH**

**NU-TEK ELECTRONICS**

5114 Balcones Wood Dr.#307 Dept.298  
Austin, TX. 78759

# IMPOSSIBLE CABLE SYSTEMS!

- ◆ Zenith PZ ◆ New Pioneer ◆ Starcom 6&7 ◆ Standard Units
- ◆ New Generation of TRIMODES & SB'S
- ◆ Quantity prices start at **\$25 each**.

Dealers only Call 1-800-933-2242  
Digital Engineering Company of America

## EDUCATION & INSTRUCTION

**F.C.C. Commercial General Radiotelephone license.** Electronics home study. Fast, inexpensive! "Free" details. **COMMAND**, D-176, Box 2824, San Francisco, CA 94126.

**LEARN IBM PC assembly language.** 80 programs. Disk \$5.00. Book \$18.00. **ZIPFAST**, Box 12238, Lexington, KY 40581-2238.

**COMPLETE course in electronic engineering.** Eight volumes. Includes all necessary math and physics. Free brochure. **BANNER TECHNICAL BOOKS**, 1203 Grant Avenue, Rockford, IL 61103.

## CABLE DESCRAMBLERS OAK M35B COMBO \$39.95

Jerrold, Zenith, Hamlin, Sci. Atlanta, Pioneer & MORE! OUR PRICES ARE BELOW WHOLESALE!

### CABLE+PLUS

14417 Chase St. #481-A Panorama City, CA 91402  
1-800-822-9955 • Other Info. 1-818-785-4500  
NO CALIF. SALES — DEALERS WANTED

## INVENTORS

**INVENTORS!** Can you patent and profit from your idea? Call **AMERICAN INVENTORS CORPORATION** for free information. Over a decade of service 1 (800) 338-5656. In Canada call (413) 568-3753.

## ECG

continued from page 46

go to both D/A converters, IC21 and IC22. To write the information to IC21 without disturbing the contents of the other D/A converter, the CPU must output a 252 to I/O port 54 to lower Q1 and Q2 of IC16, followed by a 255 to I/O port 54 to return the control signals to their inactive state.

The function of the D/A converters in the circuit are to provide a DC offset to the analog input circuitry to compensate for the DC offset produced by each ECG electrode on the patient's skin. Since the offset, in general, is different for each input lead each time the system is connected to a patient, a means to measure the offset must be provided. That is accomplished by performing a series of calibration measurements just prior to making the ECG measurements.

Next time we will continue with the construction and operation of the ECG device. **R-E**

**CABLE TV Secrets** — the outlaw publication the cable companies tried to ban. HBO, Movie Channel, Showtime, descramblers, converters, etc. Suppliers list included. \$9.95. **CABLE FACTS**, Box 711-R, Pataskala, OH 43062.

**DO it yourself, systems, upgrades, major brands discounted, save 30% — 60%. Lowest prices anywhere.** L.J.H. INC, call Larry at (609) 596-0656.

**THIS IS A REGULAR CLASSIFIED AD WITH A TINT BACKGROUND.** To have your ad appear like this one, the cost is \$3.90 per word.

### 12" Subwoofer Box

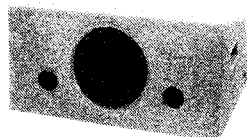

The perfect high volume cabinet for dual voice coil subwoofers. Box comes with pre-cut woofer and port holes. Cabinet volume: 2 cu. ft. with dual ports. Charcoal carpet. Dimensions: 13" (H) x 13" (D) x 30" (W). Net weight: 29 lbs.

#RJ-260-495 **\$59<sup>90</sup>** Each

### 12" Pioneer Subwoofer



**PIONEER**  
12" super duty, dual voice coil subwoofer. 30 oz. magnet, 2" voice coil. 100 watts RMS, 145 watts max power handling capability. 6 ohm impedance (4 and 8 ohm compatible). Sensitivity: 89 dB 1W/1M. Response: 25-700 Hz. QTS= .31, VAS= 10.3 cu ft. Net weight: 6 lbs. Pioneer #A30GU30-55D.

#RJ-290-145 **\$39<sup>80</sup>** **\$36<sup>80</sup>**  
(1-3) (4-up)

### 800 Hz Horn



Piezo midrange/tweeter driver unit. Response: 800-20 KHz. Power handling capability: 20-30 volts (approximately 50 watts RMS). Sensitivity: 93 dB, 2.83V/1M. 4" round. Motorola #KSN1086.

#RJ-270-085 **\$25<sup>30</sup>** **\$23<sup>95</sup>**  
(1-3) (4-up)

### 18" Eminence Woofer

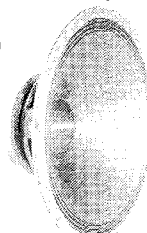

Professional driver for use in auditorium and studio sound systems. Giant 100 oz. magnet. 250 watts RMS, 350 watts max power handling capability. fs= 30 Hz, QMS= 3.17, QES= .373. QTS= .33, VAS= 10.5 cu ft. SPL= 95 dB 1W/1M. Net weight: 29 lbs.

#RJ-290-200 **\$99<sup>80</sup>** **\$93<sup>40</sup>**  
(1-3) (4-up)

### 12" Pyle Woofer



**PYLE**  
12", 70 oz. magnet woofer. 2-1/2" voice coil. 105 watts RMS, 155 watts max power handling capability.

#RJ-292-050 **\$62<sup>90</sup>** **\$59<sup>80</sup>**  
(1-5) (6-up)

### 5-1/2" Cone Midrange

Original Sanyo high end system midrange. Large 5" paper cone with gold look dust cap. Heavy 12 oz. magnet. 1" ferro fluid cooled voice coil. 50 watts RMS, 75 watts max. Sanyo part #S12H10. Net weight: 1-1/2 lbs.



**SANYO**  
#RJ-281-100 **\$5<sup>95</sup>** **\$3<sup>95</sup>**  
(1-9) (10-up)

### Subwoofer Crossover Network

Super duty, 200 watt RMS power handling capability. Designed specially for dual voice coil subwoofer systems. 12 dB per octave roll-off at 150 Hz into 8 ohms. Crossover also features a set of outputs for use with your existing speaker system. Network is totally passive, requiring no power source of its own.

#RJ-260-220 **\$28<sup>80</sup>** **\$24<sup>95</sup>**  
(1-5) (6-up)



**Parts Express**  
INTERNATIONAL INC.

**FREE CATALOG**

**CALL TOLL FREE**

**1-800-338-0531**

• 15 day money back guarantee • \$15.00 minimum order • We accept Mastercard, Visa, Discover, and C.O.D. orders. • 24 hour shipping • Shipping charge = UPS chart rate + \$1.00 (\$3.00 minimum charge) • Hours 8:30 am - 7:00 pm EST, Monday - Friday • 9:00 am - 2:00 pm Saturday. Mail order customers, please call for shipping estimate on orders exceeding 5 lbs. Foreign customers please send \$5.00 U.S. funds for catalog postage.