

# BUILD THIS DOPPLER-ULTRASOUND HEART MONITOR

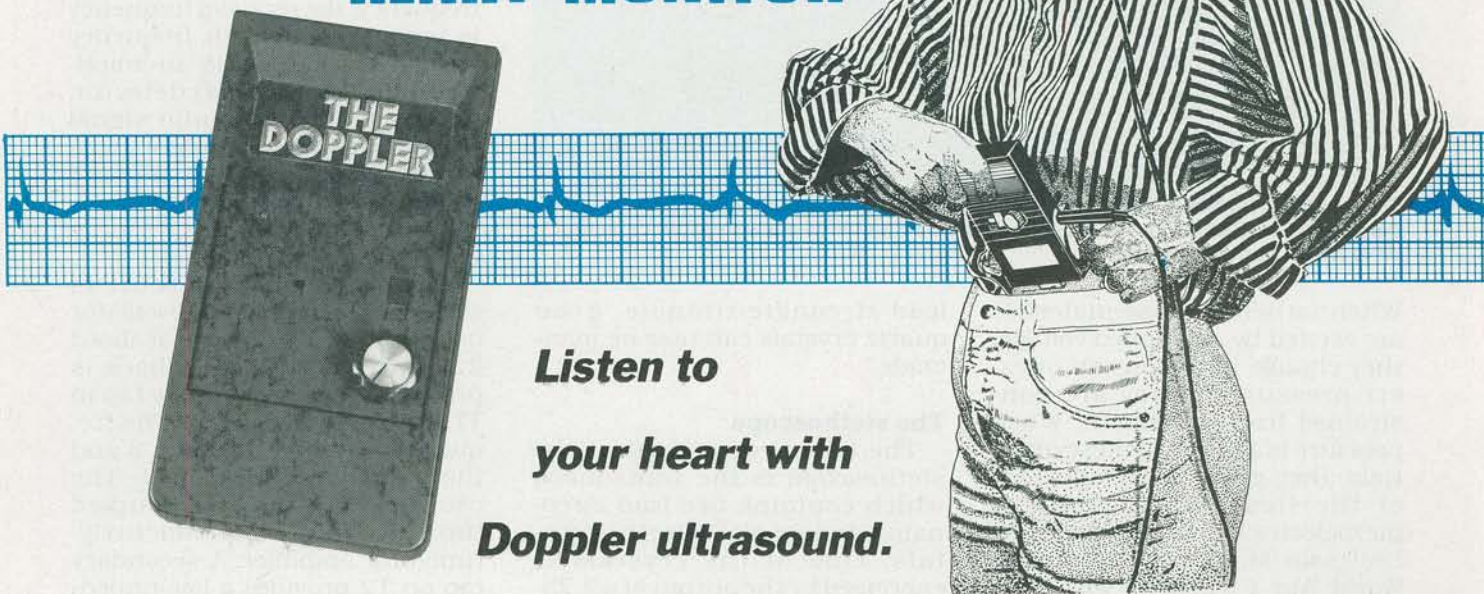

**Listen to  
your heart with  
Doppler ultrasound.**

JOE JAFFE

THE AVERAGE HUMAN HEART CARRIES out its pumping action over 100,000 times every day. Generating its own electric signals to actuate the heart muscles, the heart contracts and relaxes during each beat. We will show you how you can convert the hearts' motion into audio sounds using ultrasound electronics with our Doppler ultrasonic stethoscope. For less than \$150 you can build this educational instrument which will help you learn more about human physiology.

In 1957, an article in *The Journal of the Acoustical Society of America* described how cardiac functions could be inspected by the use of Doppler ultrasound using a frequency of about 2 MHz. The Doppler effect is the change in frequency of sound, light, or radio waves that occurs when a transmitter and receiver are in motion relative to each other. When a transducer sends an ultrasonic beam into the body, a portion of the energy is reflected back by internal body structures. If the structure moves, the fre-

quency of the reflected beam is changed in proportion to the velocity of the movement.

Almost thirty years ago this technology was developed into a valuable and completely harmless tool for non-invasive examination of movements inside the body by the medical profession. Experiments have shown that beaming very low-energy high-frequency sound into the body is not harmful. The technique is used all over the

**WARNING!!** The information contained in this article is being provided solely to readers for educational purposes. Nothing contained herein suggests that the monitoring system described herein can be or should be used by the assembler or anyone else in place of or as an adjunct to professional medical treatment or advice. Neither the publisher nor the author make any representations as for the completeness or the accuracy of the information contained herein and disclaim any liability for damages or injuries, whether caused by or arising from the lack of completeness, inaccuracies of the information, misinterpretations of the directions, misapplication of the information or otherwise.

world to listen to the heart beat of unborn babies in a mother's womb. Now you can listen to the characteristic Doppler sounds from your own heart which can be heard with an easily built Doppler ultrasonic stethoscope. It is important to note that this instrument is for experimentation and entertainment.

## **Piezoelectric background**

Transducers are devices which change one form of energy into another form. Some transducers are reversible, meaning they can change energy forms in either direction. Piezoelectric transducers are reversible. They can change electric energy into mechanical energy and mechanical energy back into electric energy. The quartz-crystal oscillator is a familiar piezoelectric transducer, which is used as a highly stable and accurate frequency source.

Early phonograph pickups used piezoelectric Rochelle-salt crystals. Both quartz crystals and Rochelle-salt crystals are naturally occurring materials.



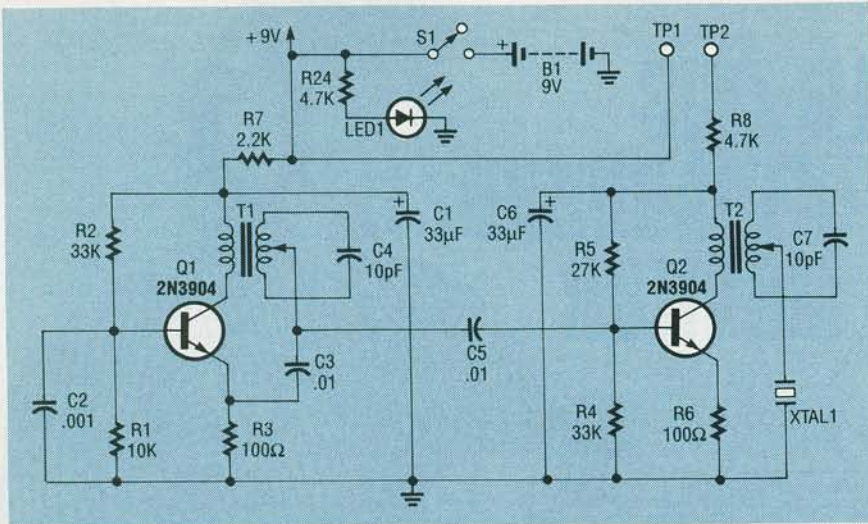

FIG. 1—THE TRANSMITTER CIRCUIT. Q1 is an RF oscillator whose 2.25-MHz frequency is determined by C4 and T1. A secondary tap on T2 provides a low-impedance output to drive XTAL1 in the transducer.

When either of those materials are excited by an applied voltage, they change in dimension or exert pressure if they are constrained from movement. When pressure is applied to these materials, they generate voltage. One of the first applications of piezoelectricity was developed by Professor M.P. Langevin during World War I when he was commissioned by the French to find a way to locate enemy submarines. He solved the problem by developing an underwater piezoelectric microphone.

About 50 years ago the first synthetic piezoelectric materials were developed. Today, commonly used synthetic piezoelectric materials include barium titanate, lithium sulfate, lead niobate, and

lead zirconate-titanate. Even quartz crystals can now be man-made.

### The stethoscope

The basic component of the stethoscope is the transducer, which contains two lead zirconate-titanate piezoelectric crystals. One of the crystals is energized by the output of a 2.25-MHz oscillator/amplifier so that it expands and contracts at that frequency, setting up pressure or sound waves that are transmitted into the body. When that wave, which is very directional, passes from one medium to another in the body, a portion is reflected back to the second crystal, which generates a voltage. If the reflecting surface is stationary,

the voltage generated by the receiving crystal has the same frequency as the transmitted wave. If the reflecting surface is moving away from the transducer, the reflected frequency is lower than the transmitted wave. Similarly, if the reflecting surface is moving toward the transducer, the reflected frequency is higher. By mixing a portion of the transmitted frequency with the received frequency, the received frequency is modulated in both frequency and amplitude. Using an amplitude-modulated (AM) detector, we can obtain an audio signal whose frequency is proportional to the velocity of the moving structure within the body.

### Circuit operation

The transmitter circuit is shown in Fig. 1. An RF-oscillator built around Q1 operates at about 2.25 MHz. Positive feedback is provided from a secondary tap in T1 to the emitter of Q1. The frequency is determined by C3 and the inductive tuning of T1. The oscillator's output is coupled through C5 to Q2, an inductively-tuned RF amplifier. A secondary tap on T2 provides a low-impedance output to drive the transmitter crystal XTAL1 in the transducer. The ultrasonic power generated is less than 15 milliwatts per square centimeter of transducer surface.

The receiver and audio circuits are shown in Fig. 2. The receiver uses two identical stages of inductively-tuned RF amplification. The voltage generated in the

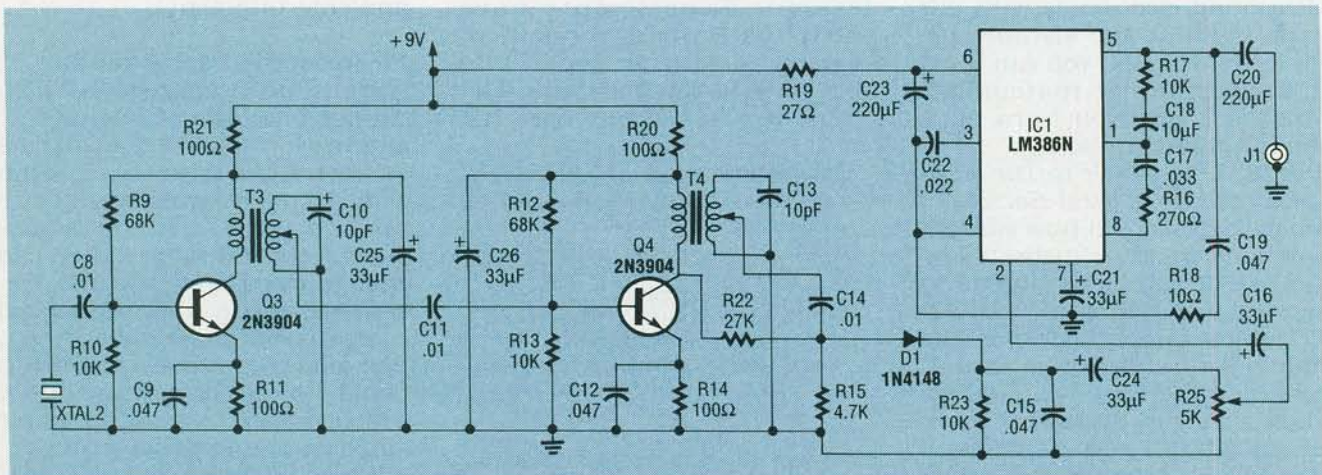

FIG. 2—THE RECEIVER AND AUDIO AMPLIFIER. The receiver uses two identical amplifier stages, with a total gain of 1000. IC1 is a low-power amp which can drive up to two headsets. Bass boost is provided by R17-C18 as many sounds generated by the Doppler effect are in the low audio range, so reducing the gain at higher frequencies improves the signal-to-noise ratio.



receiving crystal XTAL2 is coupled to Q3 through C8, and the output of Q3 is coupled to Q4 through C11. The combined RF gain for the two stages is about 2000. The modulated Doppler signal is detected by D1 to produce audio frequencies in the 50-2000 Hz range.

A low-power audio amplifier, IC1, can drive one or two headsets. It has a gain of 100, which is set by C17-R16 with some base boost determined by C18-R17, as many of the sounds generated by the Doppler effect are in the low audio range. The volume may be adjusted by potentiometer R25 at the input of IC1. The output of the amplifier goes to J1 where the headset is plugged into. If two people wish to listen at the same time, a Y-jack can be used. For classroom demonstrations, an external amplifier with speakers can be plugged in.

### The transducer

The construction of the transducer is shown in Fig. 3. The two crystals of lead zirconate-titanate (Vernitron or Channel Industries PZT5A) are  $\frac{1}{2} \times \frac{1}{4}$ -inch rectangles approximately  $\frac{1}{32}$ -inch thick. Silver electrodes are deposited on each crystal surface, and a small silver trace is carried around from one side to the other side so electrical connections to both electrodes can be made on the same side of the crystal. Fine wire, number 36 AWG or smaller, is soldered to each of the electrodes using a silver-bearing solder to avoid lifting the silver electrode from the ceramic crystal surface. Those wires are connected to the terminals of XTAL1 and XTAL2 on the circuit board. Use a minimum of solder to avoid changing the resonance characteristics of the crystal.

When dealing with ultrasound, the quantity of *characteristic acoustic impedance* is used in solving various problems dealing with waveform generation, propagation, and detection. Characteristic acoustic impedance  $w$  is defined as

$$w = \rho c$$

where  $\rho$  is the density of the medium in  $\text{kg/m}^3$  and  $c$  is the sound velocity in  $\text{m/s}$ . The characteristic acoustic impedance is, therefore, expressed as

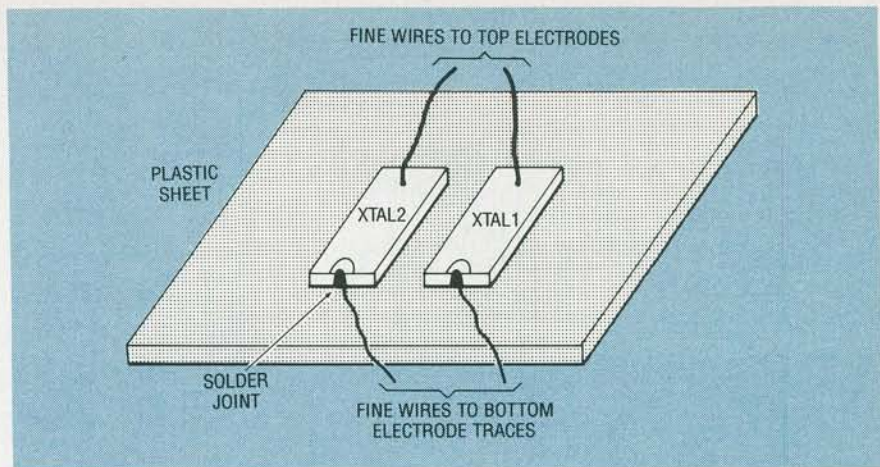

FIG. 3—TRANSDUCER CONSTRUCTION. Silver-bearing solder is used to avoid lifting the silver electrode from the ceramic crystal surface. Energy conversion is most efficient when crystals are "air-backed" resulting in energy being radiated from the front of the crystal.

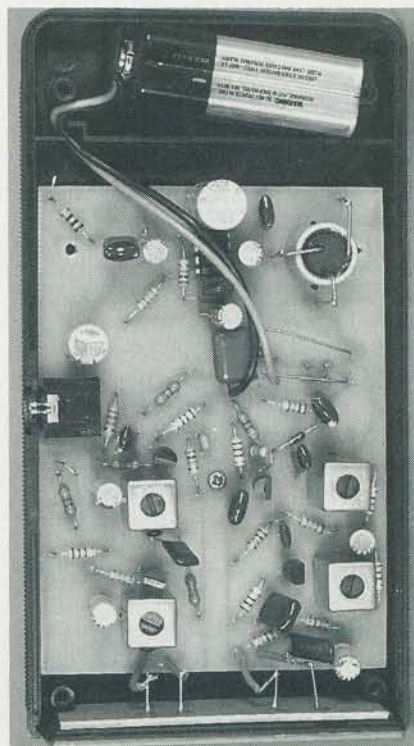

FIG. 4—THE AUTHORS' PROTOTYPE. Note that LED1 and S1 are mounted on the foil side of the PC board. The transducer is mounted on the end plate of the enclosure with its leads close to their solder pads.

### CRYSTAL SOURCES

The Piezoelectric crystals (PZT5A) mentioned in this article can be purchased from the following sources:

**Channel Industries**  
839 Ward Dr.  
Santa Barbara, CA 93111  
(805) 967-0171  
**Vernitron Piezoelectric Div.**  
232 Forbes Rd.  
Bedford, OH 44146-5478  
(216) 232-8600

$$\text{kg/m}^3 \times \text{m/s} = \text{kg/m}^2\text{s}$$

To obtain maximum energy conversion efficiency, the crystals should be acoustically matched with the plastic panel. When two mediums are closely matched, most of the energy will be transmitted through the materials. When an ultrasonic beam meets an interface of dissimilar materials, more of the energy is reflected where there is a large difference in the acoustic impedance between the two materials.

The acoustic impedance of the crystals is about 30 million and that of the body is 1.5 million, with air being less than 50, all in units of  $\text{kg/m}^2\text{s}$ . Because the density of air is so much lower than that of the crystal, and the velocity of sound in air is much slower than in the crystal, almost all the energy is reflected at that interface when the back-side of the crystals are in contact with air. That difference in impedance results in most of the energy being radiated from the front of the crystal, and improved sensitivity of the receiving crystal.

Just as you want most of the energy to be reflected at the rear of the crystal, it is desirable that most of the energy be transmitted at the front surface of the crystal and into the body. Because the crystals are too fragile to be placed in direct contact with the body, they are cemented with epoxy to a sheet of plastic about  $\frac{1}{16}$ -inch thick, which should have an acoustic impedance between that of the crystal and the body. This results in



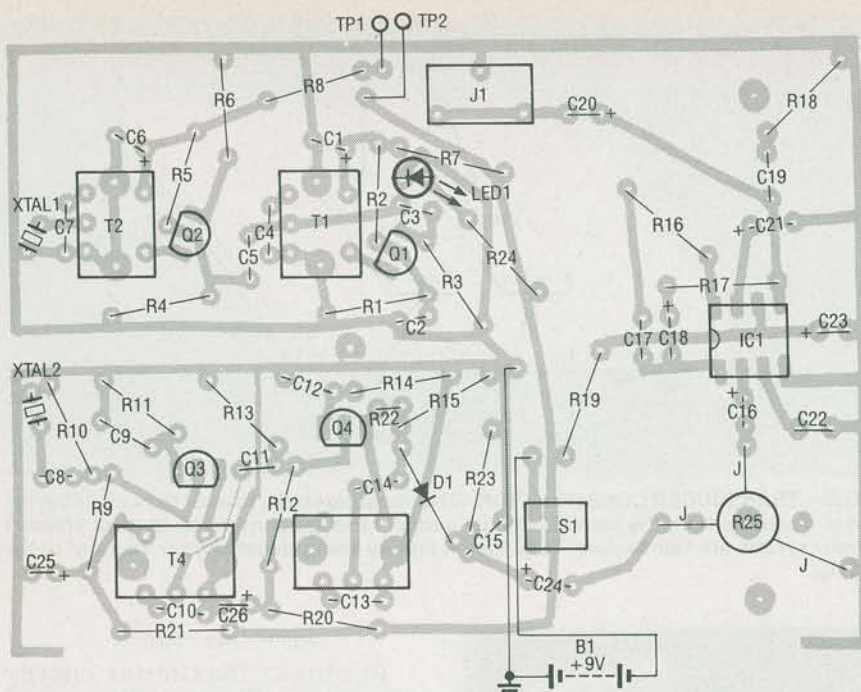

FIG. 5—PARTS PLACEMENT. Mount and solder all components as shown here.

more energy being transmitted into the body instead of being reflected at the skin surface. When gluing the crystals to the plastic, be sure to exclude any air from the interface and use a minimum amount of glue. Sheet acrylic or fiberglass such as that used for PC boards, or a rigid vinyl sheet all have suitable acoustic impedances and provide the required protection for the crystals.

When more sensitivity is required, a dab of ultrasound gel is placed on the transducer face to improve the impedance match and exclude any air that may be trapped between the transducer face and the skin. Water or mineral oil will also work.

### Construction

The authors' completed prototype is shown in Fig. 4. All the components, except the transducer, are mounted on a single-sided PC board as shown in the parts placement diagram in Fig. 5. An etched, drilled, and plated through PC board is available from the source mentioned in the parts list, or you can make your own board using the pattern provided. Note that LED1 and S1 are mounted on the foil side of the PC board. The volume control is mounted on the component side with the shaft going through the board. Use two 3/4-inch long resistor cutoffs and solder them to

TP1 and TP2. After soldering the components on the PC board, the transducer is connected.

The transducer is mounted on the end plate of the enclosure with its leads close to their solder pads. Insert the end plate and transducer into the slot on the top half of the enclosure and solder the transducer leads to their appropriate terminals. Now install the 9-volt battery. The stethoscope is now ready for tuning after you plug in the headphone.

Connect a frequency counter from the emitter of Q1 to ground. Then connect a DMM, set on the 10-mA range, between TP1 and TP2 and turn the instrument on. Your current meter should read less than 10 mA. Tune T1 to 2.3 MHz, then alternately tune T2 and T1 to reduce the current to a minimum. If you don't have a frequency counter, tune T1 for a minimum current between TP1 and TP2 and then alternately tune T1 and T2 for a lower minimum current. As the final current will be between 1 and 2 mA, use a lower 5- or 2-mA range when possible.

After you have correctly tuned T1 and T2, turn off the instrument, remove the DMM and solder the leads of TP1 and TP2 together. Connect the DMM between the cathode of D1 and ground, using the 5- or 10-volt

### PARTS LIST

All resistors are 1/4-watt, 5%.

R1, R10, R13, R17, R23—10,000 ohms  
 R2, R4—33,000 ohms  
 R3, R6, R11, R14, R20, R21—100 ohms  
 R5, R22—27,000 ohms  
 R7—2200 ohms  
 R8, R15, R24—4700 ohms  
 R9, R12—68,000 ohms  
 R16—270 ohms  
 R18—10 ohms  
 R19—27 ohms  
 R25—5000 ohms, volume potentiometer

### Capacitors

C1, C6, C16, C21, C24—C26—33  $\mu$ F, 10 volts, electrolytic  
 C2—0.001  $\mu$ F, ceramic  
 C3, C5, C8, C11, C14—0.01  $\mu$ F, Mylar  
 C4, C7, C10, C13—10 pF, ceramic, NPO  
 C9, C12, C15, C19—0.047  $\mu$ F, Mylar  
 C17—0.033  $\mu$ F, Mylar  
 C18—10  $\mu$ F, 10 volts, electrolytic  
 C20, C23—220  $\mu$ F, 10 volts, electrolytic  
 C22—0.022  $\mu$ F, Mylar

### Semiconductors

Q1—Q4—2N3904 NPN transistor  
 D1—1N4148 diode  
 LED1—red light emitting diode  
 IC1—LM386N low-power amplifier

### Other components

T1—T4—MOS-E911 transformer (Sumida)  
 XTAL1, XTAL2—1/2  $\times$  1/4  $\times$  0.035-inch PZT5A (Vernitron or Channel Industries)  
 S1—SPST slide switch

**Miscellaneous:** 9-volt alkaline battery, PC board, miniature stereo jack, 16-ohm stereo headphone, and silver bearing solder.

**Note:** The following items are available from Products & Processes, 9450 Mira Mesa Blvd., Suite #B-321, San Diego, CA 92126 (619) 566-0711:

- A fully assembled and tested instrument with cassette—\$189.50.
- A complete kit of all parts (without battery) including an assembled transducer, PC board, headphone, assembly manual, case, and cassette with typical sounds—\$135.
- An etched, drilled, and plated through PC board—\$8.50.
- A pair of piezoelectric crystals—\$39.50.
- Four MOS-E911 transformers (T1—T4)—\$12.

California residents add 8 1/4% sales tax. Add \$5.00 shipping and handling.



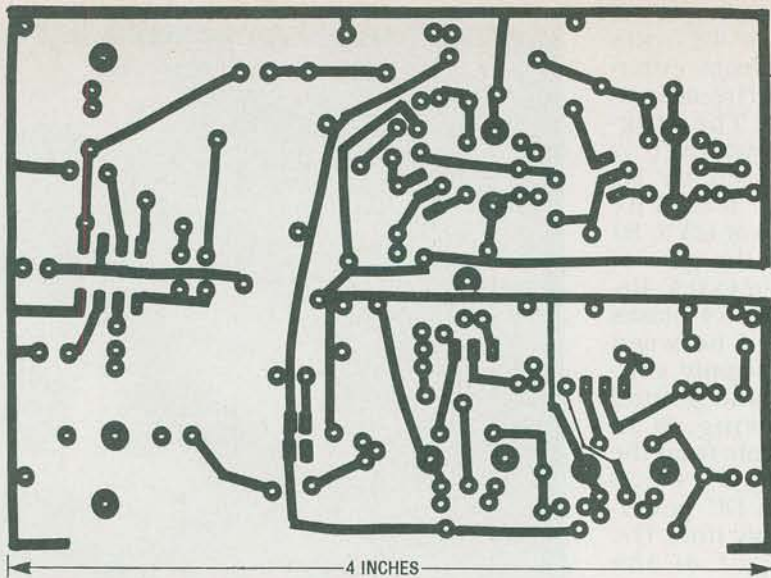

THIS IS THE SOLDER side of the PC board.

range. Alternately tune T3 and T4 for a maximum voltage, which will vary between 1 and 2 volts.

If you don't have a frequency counter or DMM available, you can tune the stethoscope while listening to your heart. With the transducer and headphones connected to the circuit board, put a little mineral oil or ultrasound gel on the face of the transducer and place the transducer firmly on your chest near your heart. Try to place the transducer between a pair of ribs rather than directly over a rib. Turn the volume up until you hear some Doppler sounds, which will probably be low, as well as a hissing noise. Alternately tune T1-T4, starting with T3 and T4, to increase the volume and reduce the hissing. Turn down the volume control during this tuning to prevent overloading and distortion.

If you don't hear any sounds with the above procedure, put a few drops of water on the transducer face and rub it with your finger. If that doesn't produce any sounds, check the circuit board for solder bridges and cold solder joints.

#### Testing and use

As mentioned earlier, maximum sensitivity is obtained when there is a good impedance match between the transducer face and the skin, with no air is trapped between them. A liquid-gel such as Aquasonic is specifically made for that purpose and is available at medical supply stores.

Apply a small amount of liquid gel to the transducer surface and place the transducer firmly against the bare chest, several inches to the left of the center and about 10 inches below the shoulder. Place the transducer so the ultrasonic beam passes between two ribs for best transmission. You will hear the sounds associated with the movement of the heart. Keeping the transducer firmly against the chest and changing the direction of the ultrasonic beam you will hear different sounds depending on what surfaces are in the path of the beam. When you take a deep breath the sounds may disappear because the lungs fill with air, covering a portion of the heart. As previously noted, air is a poor conductor of high-frequency sound.

There are many aspects of heart action. First, returning blood from the venous system fills the right atrium. A valve connecting this atrium to the right ventricle then opens and contraction of the atrium forces the blood into the ventricle. The valve then closes and another valve connecting the ventricle to the pulmonary artery opens. The right ventricle contracts, forcing blood into the pulmonary system to return carbon dioxide to the lungs to be exhaled and to pick up oxygen from the air we breathe in. The blood then returns to the left atrium where it is pumped into the left ventricle through another valve. Finally the left ventricle contracts,

pumping blood into the arterial system to feed the body and the heart itself.

Each of the four chambers of the heart contract and relax at different times of the heart cycle. Their associated valves open and close synchronously. The movement of all those structures and the movement of blood through them provide the Doppler sounds which you hear with the Doppler ultrasonic stethoscope.

When you move the transducer across the skin you'll hear some scratching sounds. To avoid this, turn the volume down while you move the transducer.

Because there is attenuation of the sound wave as it passes through the body, those with a heavy build may have to try alternate body positions to bring the heart closer to the chest wall. Two suggested positions are lying on the left side or leaning forward in a sitting position.

When listening to the heart with Doppler ultrasound a number of different sounds are heard, one after the other, in rapid succession as the heart chambers and valves move and the blood flows through them. One can listen to blood flow separately from other sounds by placing the transducer on the neck where you feel the pulsation of the carotid artery. Because the artery is small compared to the heart, it will take some time to learn how to orient the transducer in the direction of blood flow through the artery. You must use the gel for that experiment. You may be able to hear a slight change in blood flow corresponding to the dicrotic notch in the pulse wave.

Blood flow sounds may also be heard from the brachial artery in the arm on the inside of the elbow. That is the location where the physician places the stethoscope when measuring blood pressure. The transducer is again oriented in the direction of blood flow and gel must be used. When listening to the blood flow in the brachial artery, you may want to try an experiment. Clench your fist to stop the flow of blood in the hand for about 5 or 6 seconds. When the fist is unclenched the blood flows again and you will hear some interesting wind-like sounds.

R-E



# Listen to your Heart with Doppler Ultrasound

*Ultrasonic stethoscope lets you hear snapping  
of heart valves and blood-flow sounds.*

BY JOSEPH JAFFE

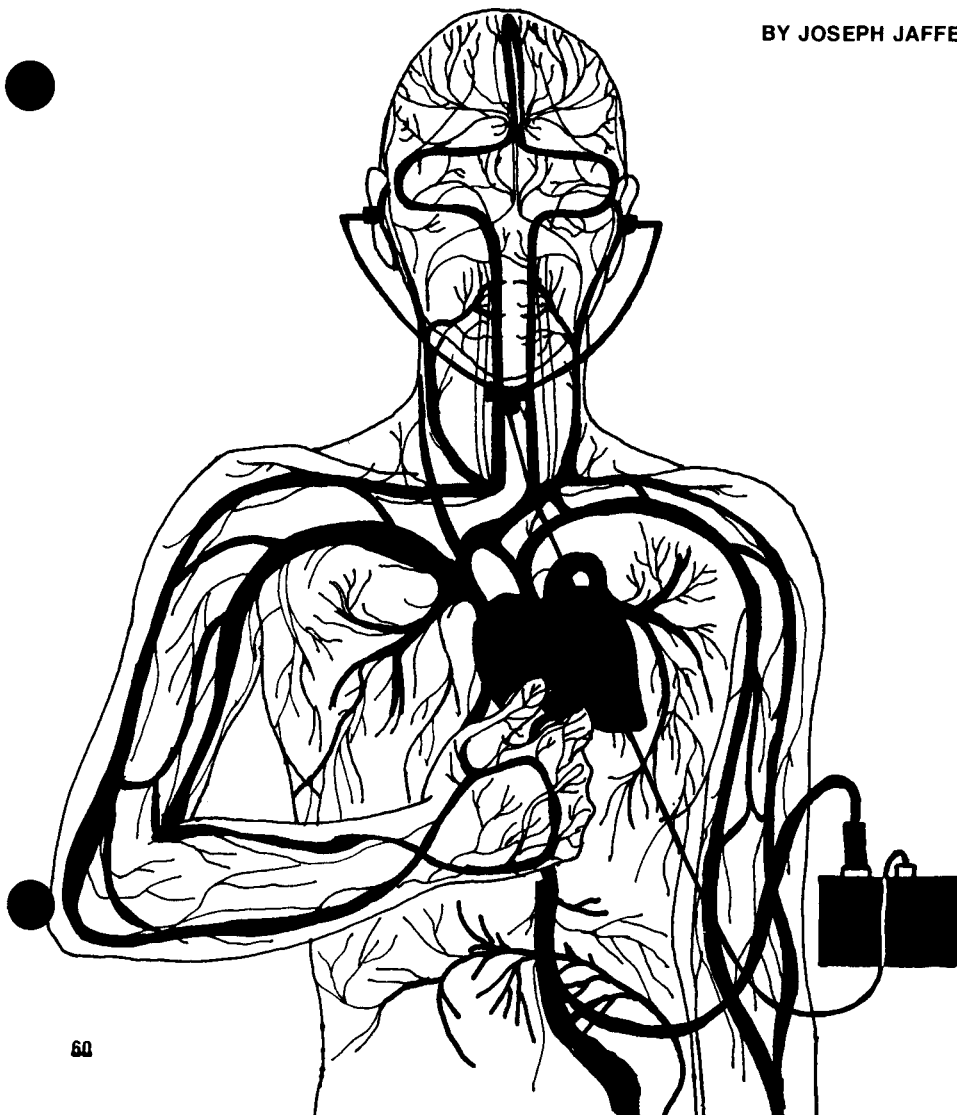

**A**BOUT 15 years ago, it was discovered that, when ultrasonic energy in the low-megahertz range is beamed into the body, the energy is reflected back to the surface by certain internal structures. If the structures move, the frequency of the reflected energy is changed in proportion to the velocity of the movement due to the Doppler effect. Development of this principle has given the medical profession a valuable and completely harmless tool for the noninvasive examination of movements inside the body—especially of the heart, its valves, and the flow of blood within the heart. All of the movements cause characteristic sounds which can be heard with the aid of an easily constructed ultrasonic stethoscope.

The basic elements in the stethoscope are two lead zirconate-lead titanate piezoelectric crystals. One of the crystals is energized by a signal from a 2-MHz oscillator so that it expands and contracts setting up pressure or sound waves that are transmitted into the body. When this wave (which is very directional) passes from one medium to another in the body, a portion is reflected back to the second crystal, which generates an electrical signal. If the reflecting surface is stationary, the signal generated in the receiving crystal is 2 MHz. If the reflecting surface is moving away from the transducer, the frequency is lower than the transmitted wave. Similarly, if the surface is moving toward the transducer, the reflected frequency is higher. By mixing a portion of the transmitted frequency with the received frequency and detecting the difference, we get a frequency in the audio range that is proportional to the velocity of the reflecting surface.

**Circuit Operation.** In the transmitter circuit (Fig. 1) Q1 operates as a 2-MHz oscillator. Positive feedback is

**Editor's Note.** Experiments have shown that beaming high-frequency sound into the body is not harmful. The technique has even been used successfully in listening to the hearts of unborn babies in the mothers' wombs.

It should be remembered, however, that this project is for experimentation and entertainment. Do not attempt to interpret the sounds diagnostically for yourself or for others. Only a physician can do this by correlating the sounds with other medical information.

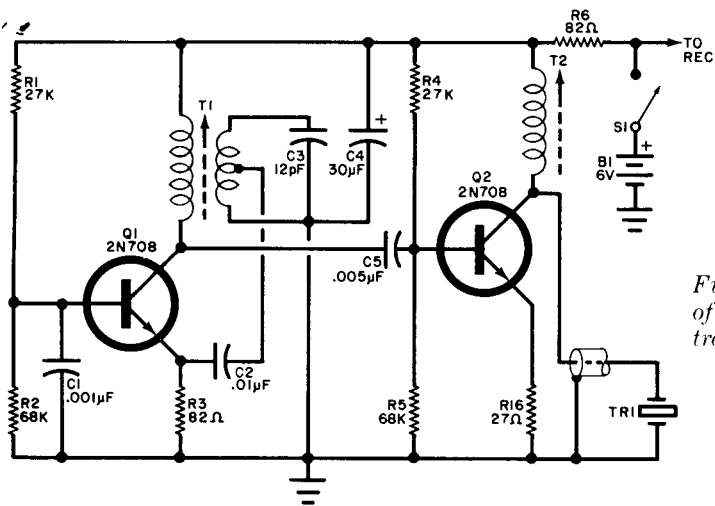
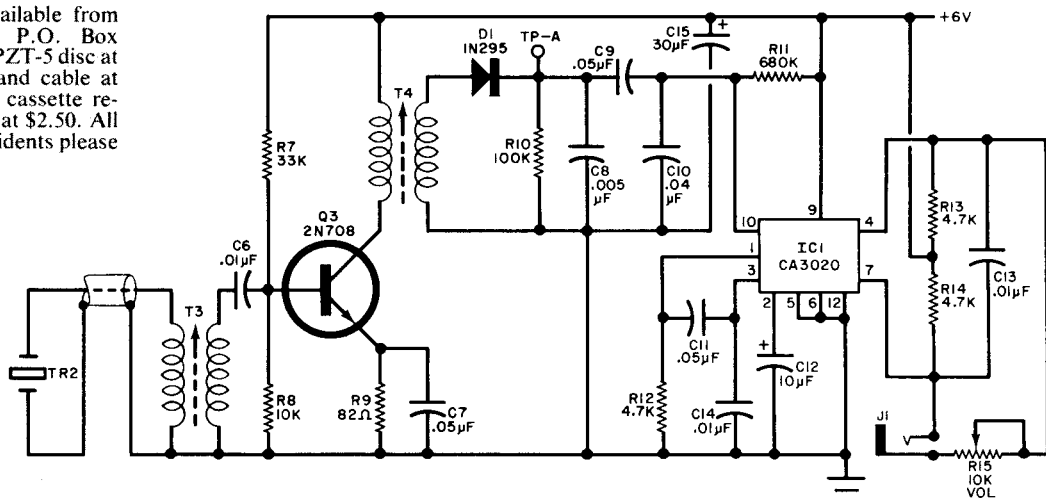

Fig. 1. Schematic of the stethoscope transmitter circuit.

### PARTS LIST

- B1—6-volt battery (4 AA cells)
  - C1—0.001- $\mu$ F polystyrene capacitor
  - C2, C6, C13, C14—0.01- $\mu$ F polystyrene capacitor
  - C3—12-pF ceramic disc capacitor
  - C4, C15—30- $\mu$ F, 15-V electrolytic capacitor
  - C5, C8—0.005- $\mu$ F polystyrene capacitor
  - C7, C9, C11—0.05- $\mu$ F polystyrene capacitor
  - C10—0.04- $\mu$ F polystyrene capacitor
  - C12—10- $\mu$ F, 15-V electrolytic capacitor
  - D1—Diode (1N295 or 1N4148)
  - IC1—Audio amplifier (RCA CA3020)
  - J1—Phone jack
  - Q1 to Q3—Transistor (2N708, 2N5134)
  - Unless otherwise noted, following are  $\frac{1}{4}$ -watt, 10% resistors:
  - R1, R4—27,000 ohms
  - R2, R5—68,000 ohms
  - R3, R6, R9—82 ohms
  - R7—33,000 ohms
  - R8—10,000 ohms
  - R10—100,000 ohms
  - R11—680,000 ohms
  - R12 to R14—4700 ohms
  - R15—10,000-ohm potentiometer
  - R16—27 ohms
  - S1—Spst switch (on R15)
  - T1 to T4—Transformer (Lafayette #99-6300)
  - TR1, TR2—PZT-5 Vernitron Piezoelectric 16035 disc (see text and note)
  - Misc.—2-conductor individually spiral-shielded cable, plastic or metal tube ( $1\frac{1}{4}$ " ID  $\times$  2"), cork or foam, epoxy, silver-bearing solder, Telex HMY-2 or #799 2000-ohm headset, knob, mounting hardware, etc.
- Note—The following are available from Products and Processes, P.O. Box 380066, Miami, FL 33138: PZT-5 disc at \$22, complete transducer and cable at \$49.50, pc board at \$4.50, cassette recorded with typical sounds at \$2.50. All prices postpaid. Florida residents please include 4% sales tax.

Fig. 2. Receiver uses the same type of transducer as the transmitter.



The detected audio signal is amplified by IC1.

**Construction.** The circuits are assembled on a single pc board, using the foil pattern and component installation shown in Fig. 3. Since IC1 is in a round, TO-type package, you must bend its leads to conform to the in-line bend pads on the board.

Construction of the transducer assembly is shown in Fig. 4. The two transducers are made by carefully cutting in half a 1-inch diameter PZT crystal ( $\frac{1}{32}$ " thick) to make two D-shaped devices. Fine wire, such as #36 or smaller, should be soldered to each side of the crystal using silver-bearing solder to avoid lifting the ultrasonic energy is radiated from the front of the crystal. Most of the ultrasonic energy reaching the air-backed surface is reflected to the front because of the poor acoustic matching. As shown in Fig. 4, a porous material such as cork or foam is suitable for mounting the crystals to achieve the air backing. The two crystals are secured to the backing material with small amounts of adhesive, with the two flat edges of the D shapes about  $\frac{1}{16}$ " apart. The thin wires soldered to the crystals are threaded through the backing material.

A 4' or 5' length of two-conductor, individually shielded cable is soldered to the thin wires, making sure the solder joints don't touch any other connection or metal. The entire assembly is then encapsulated with epoxy. The active faces of the transducers should

provided from the secondary of T1 through C2. The frequency is determined by the value of C3 and the tuning of T1. The oscillator is coupled through C5 to Q2, an amplifier whose output is tuned by T2. The amplified signal is then coupled to the transmitter transducer TR1 through a length of shielded cable. The transmitter generates about 25 milliwatts per square centimeter of transducer surface.

In the receiver (Fig 2), the voltage generated across TR2 by the reflected ultrasonic signal is coupled to Q3, a tuned amplifier with a gain of approximately 300. The signal is detected by D1. Though it might appear that an FM detector would be used here, the AM detector provides better sensitivity and is simpler to construct. It also requires no alignment. Amplitude detection can be used because a portion of the transmitted pressure wave is directly coupled to the receiver transducer at the surface of the body. The mixing of the direct wave with the reflected wave causes amplitude modulation at a frequency determined by the Doppler effect.

be slightly below the edge of the tube and covered with epoxy for insulation. Be sure there are no air bubbles in this coating.

Connect the transducer cable to the pc board as shown in Fig. 3, with each shield connected to ground.

The pc board and batteries, with S1, R15 and J1, can be mounted in any suitable enclosure.

When assembly is complete and the circuit is energized, you should hear a low-level hiss coming from the stethoscope. Connect a 20,000-ohms/volt meter across the diode load resistor (test point A to ground) and tune the oscillator transformer (T1) and amplifier transformer (T4) for maximum voltage. If you don't have a voltmeter, fill a water glass half full and immerse the transducer about one inch into the water. Keeping the face of the transducer under water, oscillate it rapidly up and down, listening for the Doppler effect as the sound is reflected from the bottom of the glass. Tune the transformers for maximum volume and best signal-to-noise ratio.

**Testing and Use.** To get good results, the acoustical impedance of the transducer must be matched to that of the body so that the pressure waves are transmitted into the body rather than reflected back at the skin surface. To obtain an impedance match, use a liquid or a liquid-gel between the transducer and the skin. Water, olive oil, or mineral oil will work; but better results will be obtained with a liquid-gel such as Aquasonic or Sonigel, which are specifically made for this purpose and are available in medical supply stores.

Apply a small amount of liquid or liquid-gel to the active transducer surface and place the transducer firmly against the bare chest several inches to the left of center and about 10 inches below the shoulder (Fig. 5). Place the transducer so that the ultrasonic beam passes between two ribs, for best transmission. You should be able to hear the movement of the heart. Remember that, as you change the direction in which the transducer faces (always keeping it firmly against the chest), the sounds you hear will change, depending on what surfaces are in the path of the beam. When you take a deep breath, the sound may disappear because the lung fills with air, covering a portion of the heart; and air is a poor conductor of high-frequency sound.

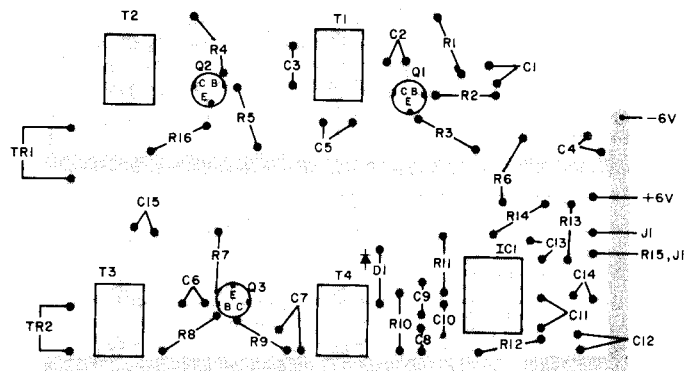
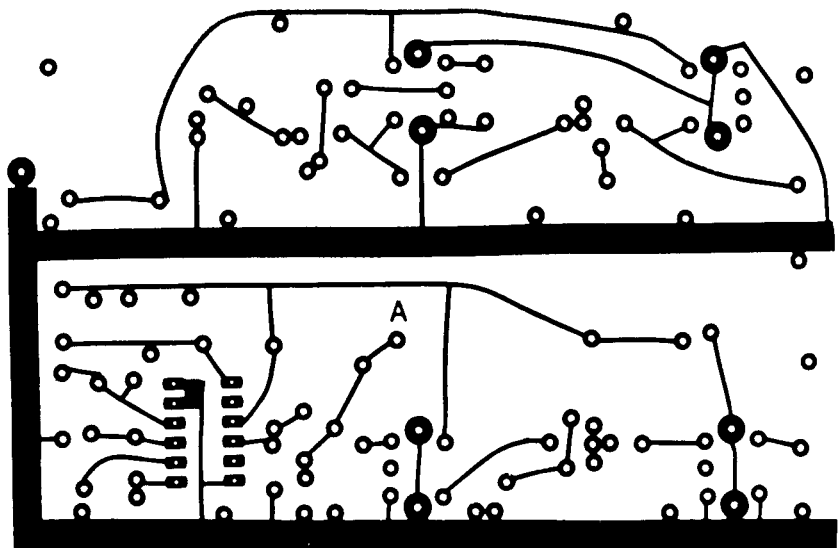

Fig. 3. Etching and drilling guide for printed circuit board is at top. Component layout below.

Typical sounds are the low-pitched "harrumph-oomph" of the heart wall, the snapping sounds of the heart valves, and the "shushing" of blood flow. These sounds occur briefly during each heart beat, and you will quickly learn to recognize the distinctive sounds. You will be able to study the effects of slow or fast breathing on your heart rate, as well as the effect of exercise.

If you are interested in biofeedback training, you may want to try to control your heart rate by meditation or other

means. You will be able to hear the changes if you are successful.

Because there is attenuation of the sound wave as it passes through the body, those with a heavy build may find it necessary to try alternate body positions to bring the heart closer to the chest wall and the transducer. Two suggested positions are lying on the left side or leaning forward in a sitting position.

After you have successfully heard the Doppler sounds in one area, you can move the transducer to other

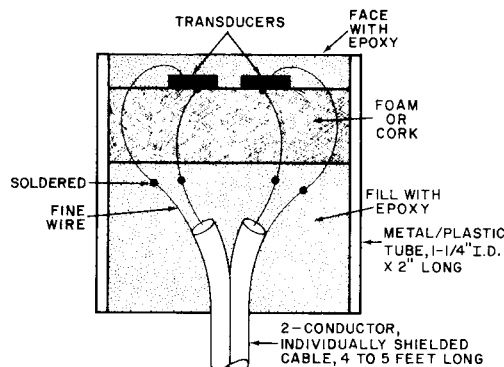

Fig. 4. Diagram shows how to assemble transducers for transmitter and receiver in stethoscope.





*Fig. 5. To hear heart sounds, place the transducer about 10 inches below shoulder*

areas to compare the sounds. Rocking the transducer back and forth in one position will also change the sound as the direction of the beam changes. This helps bring in the valve and blood-flow sounds. If loud scratchy sounds are heard when moving the transducer around, turn off the stethoscope while moving it.

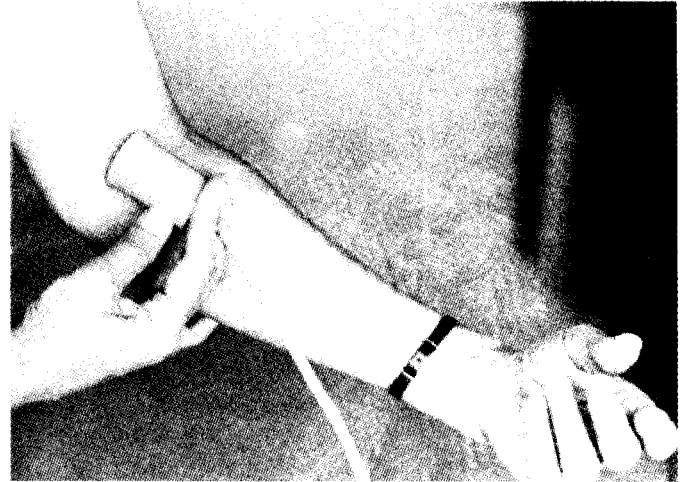

*Fig. 6. To hear blood in arm vein, the transducer must point up toward shoulder.*

It is sometimes possible to hear the flow of blood in the main (brachial) artery in the arm along the inside of the elbow (Fig. 6). In this case, the transducer is not placed flat against the arm but is oriented so that the beam points along the arm in the direction of the blood flow (toward the shoulder). The beam is then reflected

from the red blood cells; and when you have located the artery correctly, you will hear a short "pshhh" sound with each heart beat. For this experiment, use enough liquid-gel to fill the space between the tilted transducer face and the arm. It will also be necessary to use an external amplifier and speaker to get better sensitivity. ♦