

Scale Deposit



Christian Vossen

Hard water is still the cause of all sorts of problems, in spite of the fact that standard tap water these days is (partially) decalcified. Scale deposits can lead to the failure of heating elements in various appliances or cause blockages in boilers, with possibly not insignificant financial consequences. Fortunately it is quite easy to do something about it!

Although the water supplied by nearly all utilities these days is (partially) decalcified, it can still be worthwhile to soften the water a little more. Assuming a hardness of 8 German degrees ($^{\circ}\text{D}$) — not uncommon in the UK — there is still a moderate amount of calcium hydrogen carbonate dissolved in the water. If the water is heated, then insoluble calcium carbonate is formed (this is popularly referred to as calcium or scale deposits). The very fine calcium carbonate particles deposit mainly on the hot parts of appliances that heat water and form the notorious scale (for example on the heating element of a washing machine or the bottom of a cooking pot).

There exist a number of methods to make hard water soft which make clever use of chemical processes. One method that does not involve chemistry requires the application of a very strong magnetic field. When the water flows through such a field, larger calcium particles are formed by coagulation which do not deposit quite so easily onto a surface. The result: no calcium stains on sanitary fittings and no scale deposits on heating elements.

The water has not really been made any softer after this treatment because all the calcium is still there, it is just that it is not causing us any trouble any more. In addition, we don't really need to get rid of this calcium anyway because this mineral is only harmful to appliances but not to humans (quite the contrary).

Whether such an (electro)magnetic water-'softener' actually works is a topic of fierce debate with widely ranging opinions. Feel free to Google the Internet for more information on this subject.

Whatever can be done with a magnetic field can also be done (or at least it appears that way) with electromagnetic fields. With a handful of parts for just a few pounds we can make such an electronic water softener ourselves.

The circuit drives a couple of coils that function as transmitting antennas. They are wrapped around the water pipe, so that an electromagnetic field (the radio waves) is induced in the water. In order that both the magnetic as well as the electric field components of the radio waves can penetrate into the water it is best that the coil antennas

are wound around a (section of) plastic water pipe.

Schematic

The operation of the circuit is as follows (refer to **Figure 1**). An oscillator is built around two of the inverters in IC1 with R2 and C1. This oscillator is tuned to about 2 kHz ($t = 2.2 R2C1$). This signal is subsequently buffered by two inverters connected in parallel and sent to coil L1. This signal is inverted again and connected to coil L2, so that between the two coils there is a square-wave voltage with a peak-to-peak value that is double that of the power supply voltage. The supply voltage is regulated with a 78L09.

You can easily make the coils yourself from copper wire with a diameter of about 1 mm. Take two pieces of about a meter long (depending on the diameter of the water pipe and the desired number of turns) and make with each wire about 15 turns around the water pipe. It is best if the windings are separated from each other a little. Make sure that the winding direction is the same for both coils. Refer also to **Figure 2**. For the power supply you can use any

Fighter a simple water softener

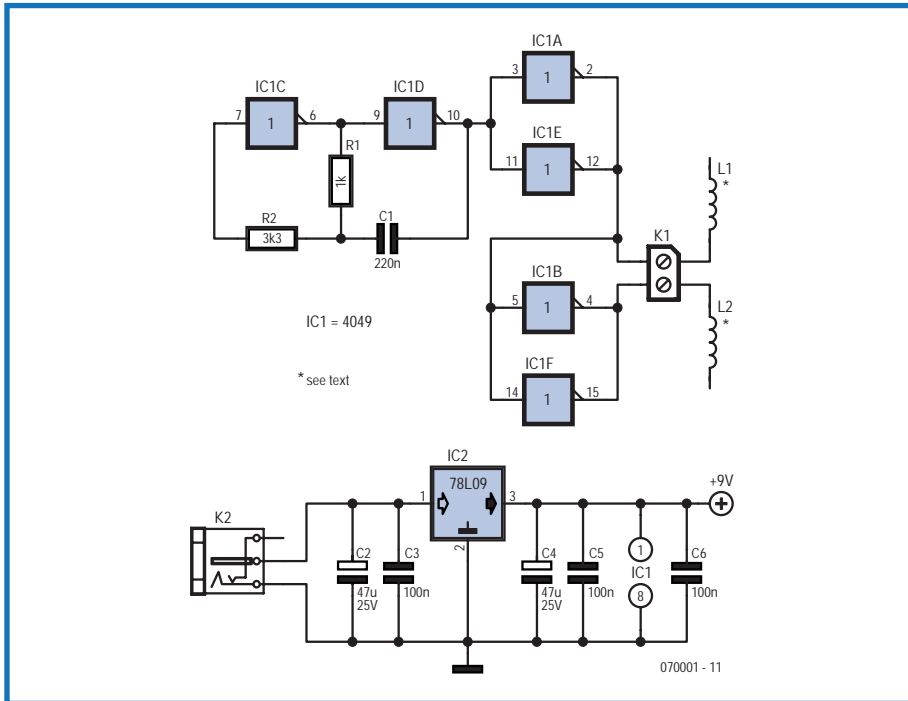

Figure 1. The schematic comprises only 10 components and 2 connectors.

spare mains wall adapter that supplies a DC voltage in the range from 12 to 15 V.

Experimenting

There is of course plenty of scope to experiment with this circuit: you can put the windings closer together, increase the frequency, reverse the winding di-

rection of the coils, change the location of the coils on the water pipe, try whether the coils work better around a copper pipe or a plastic one (the latter has our preference), and many more.

How much effect this circuit ultimately has can only be established over the long term. Some users of such electronic water softeners (which includes

a few colleagues) are wildly enthusiastic about them, while others assert that they notice absolutely no difference. So just try it for yourself, you can build this circuit for a mere few pounds and that is considerably cheaper than similar read-made devices that can be bought in the shops for this purpose.

(070001-1)

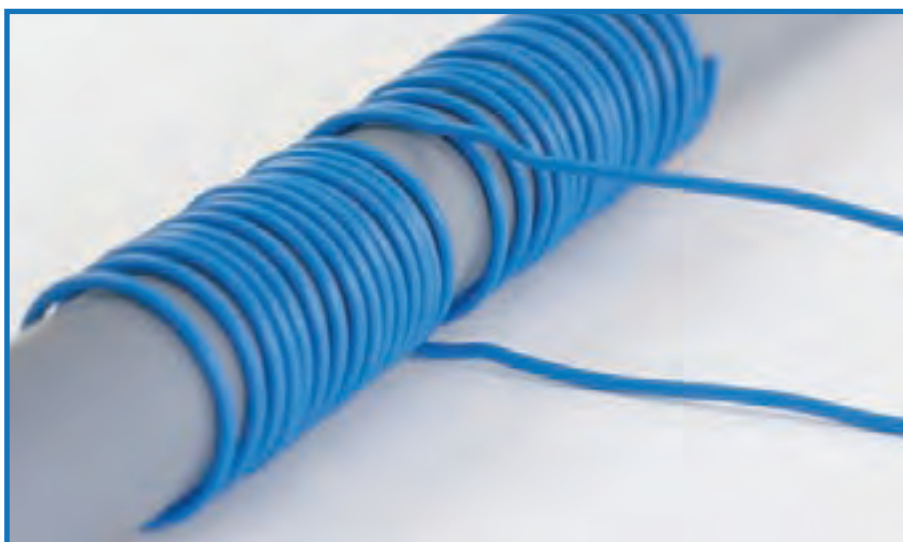

Figure 2. The coils L1 and L2 consist of about 15 turns which are placed next to each other.

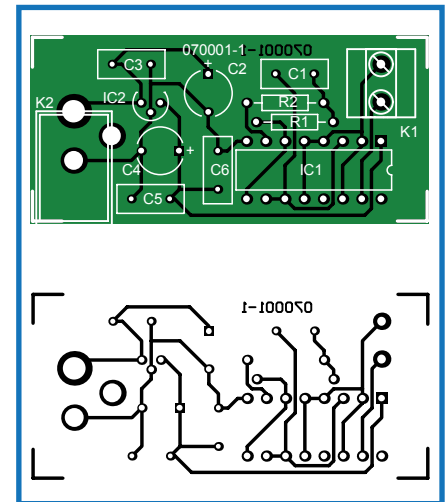

Figure 3. The PCB layout is not very difficult at all with so few components.

COMPONENTS LIST

Resistors

R1, R2 = 1kΩ

Capacitors

C1 = 220nF

C2, C4 = 47µF 25V

C3, C5, C6 = 100nF

Semiconductors

IC1 = 4049

IC2 = 78L09

Miscellaneous

K1 = 2-way PCB terminal block, lead pitch 5mm

K2 = DC adapter socket

PCB, ref. 070001-1, from ThePCBShop (see www.elektor-electronics.co.uk)