

Fig. 1. Wiring of thermostat circuit when it is less than 375 mA (A) and more than 375 mA (B).

PARTS LIST (Fig. 1)

K1—24-V ac (75 ohms or more) relay, 2-A normally open contacts (Potter & Brumfield KA5AY-24VAC or Guardian 1310-4C-24VAC or equivalent)
 R*—12-W (or more) resistor (see text)
 S1—Spst switch (dpdt for 3-wire heating control system)(see text)
 S2—Freeze sensor (MCI TS-5B19)

Misc.—Thermostat wire, solder, labels, screws, etc.

Note: The following is available from Magicland Electronics, 4380 S. Gordon, Fremont, MI 49412: MCI TS-5B19 freeze sensor (trip point guaranteed by MCI to be between 1°

and 7°C) at \$6.25 each, postpaid, via first class mail. Also available are the TS-5B19A (trip point 38°F ±2°F), TS-5B19L (trip point 35°F ±2°F), and TS-5B19H (trip point 42°F ±2°F) at \$9.85 each, postpaid.

saving thermostat into your heating system is to find out how much current flows through your present thermostat. You can look up this information, but it's preferable to take measurements.

To measure the current, you will need an ac milliammeter that can read to 1000 mA. Disconnect the two wires from your thermostat and connect the meter's leads to these wires. Make a note of the current. If it is less than 375 mA, only a spst switch and a tempera-

ture-sensing reed switch are required to make a complete energy-saving system.

Now measure the resistance of your thermostat's heat anticipator. With the wires to the thermostat disconnected, set the thermostat as high as it will go, making sure the contacts close. Connect an ohmmeter across the thermostat's terminals and make a note of the measured resistance. This resistance we will call *R1*.

Figure 1A shows how to add an ener-

gy-saving thermostat to a furnace that requires less than 375 mA of control current. Be sure to use #18 thermostat wire when making connections. Locate switch *S1* near your present thermostat and label it **NORMAL** when it is closed and **ENERGY-SAVING** when open. The temperature-sensing reed switch, *S2*, can be mounted either next to the old thermostat or in an area of the house where freezing could be especially damaging while you're away.

TYPICAL FURNACE-CONTROL CIRCUITRY

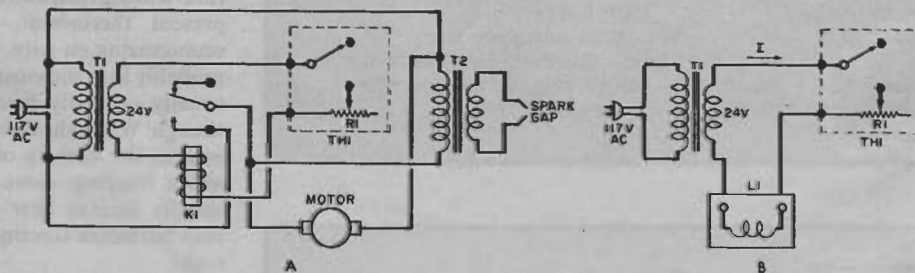

Most, but not all, oil and gas furnaces use low-voltage (24 V ac) thermostat control systems. Figure A shows a simplified wiring diagram of a typical oil-fired furnace. *T1* is a 24-V transformer and *TH1* is a low-voltage thermostat with an adjustable heat anticipator (resistance *R1*). Relay *K1* has normally open contacts and a 24-V ac coil. The oil-pump motor and ignition transformer *T2* lead to the spark gap. (Numerous safety-related circuits and com-

ponents of the furnace are not shown.) The operation of a typical oil-fired furnace is simple. When the temperature of the thermostat drops below its setting, the contacts close and 24 V ac is applied to *K1*'s coil. With its coil energized, *K1* pulls its contacts closed and line voltage is applied to the motor and *T2*. The motor *M1* then starts pumping oil, while *T2* steps up the voltage to between 10,000 and 12,000 V. The high voltage from *T2*'s secondary

causes a spark and the oil ignites. Not mentioned are the many safety-related circuits such as flame detector, oil-over-flow detector, overheat controls, etc. A grossly oversimplified wiring diagram that is typical of either a gas or oil furnace is shown in Fig. B. Here *L1* is either a 24-V relay or control-valve operator. *T1* and *TH1* are exactly the same as before. (For simplicity, the furnace's other electrical parts are not shown.)

The operation of the device is simple. When *S1* is closed, the circuit operates exactly as it did originally—*S2* is bypassed and only thermostat *TH1* controls the valve operator *L1*. When *S1* is in the ENERGY-SAVING position, *S2* controls *L1* because *TH1*'s contacts will always be closed in the temperature range of interest, which is 35° to 40°F.

If you find that more than 375 mA normally flows through your present

thermostat, it is best to have *S2* control a relay instead of controlling *L1* directly. This insures a long life for *S2*. The relay will then control *L1*. Figure 1B shows a suitable circuit for this.

In addition to relay *K1*, Fig. 1B shows optional resistor *R**. This is a 12-W or larger unit whose resistance is equal to that of the thermostat's heat anticipator *R1*. (*R** limits *L1*'s current to the same value it was originally. *R** is

probably not needed in most systems and its use is optional. To be on the conservative side, however, it is recommended that *R** be placed in series with *L1*.)

When connecting *K1* to the furnace's circuit, make sure you use #18 thermostat wire. Mount *K1* in the same general area as the furnace's other electrical parts. As before, label *S1* NORMAL when closed and ENERGY-SAVING when open. Relay *K1* can be any type having a 24-V ac coil that draws less than 375 mA and has normally open contacts with a 2-A or higher rating.

Now, with *S1* in the NORMAL position, only *TH1* controls *K1*. The reason is that *S2*'s contacts are only closed when the temperature approaches freezing—which we assume never happens when *S1* is in the NORMAL position (except for a power outage or furnace failure). With *S1* in the ENERGY-SAVING position, *TH1* is disconnected from the circuit and only *S2* controls *K1*. When *K1*'s coil is energized, its contacts are pulled closed, 24 V is applied to *L1* and the furnace starts up.

The wiring diagrams shown in Fig. 1 pertain to 2-wire heating thermostat circuits as well as most newer types of heating/cooling thermostat circuits with 3, 4 or 5 wires. However, if you have a 3-wire, 24-V ac heating thermostat (rare today) that controls less than 375 mA, you can't use either circuit. But, don't despair! You can easily construct an energy-saving thermostat. See Fig. 2. The only significant change from Fig. 1A is that a dpdt switch is used instead of the spst type.

The best place to mount the temperature-sensing reed switch is close to your present thermostat. In addition to economizing on wire, this location will probably save the most energy since it is usually centrally located. Be careful, though! While the furnace will keep the area in the vicinity of the sensor well above freezing, some critical regions, usually located near an outside wall, may fall below freezing on a bitter cold night.

To be on the safe side, locate *S2* in a critical area. A good place would be near a water pipe that has caused trouble in the past. Actually, you can place as many sensors around the house as you like. By doing this, the circuit will continually monitor all areas that can be damaged by freezing. The furnace will go on whenever one sensor gets cold enough. (When wiring additional sensors into the circuit, be sure to connect them in parallel.)

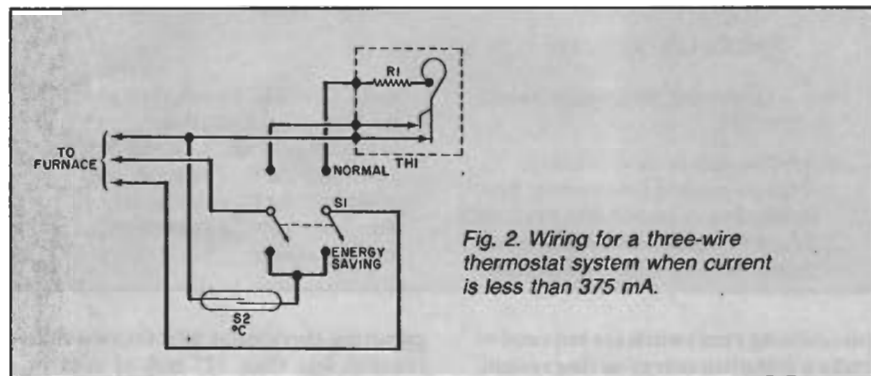

Fig. 2. Wiring for a three-wire thermostat system when current is less than 375 mA.

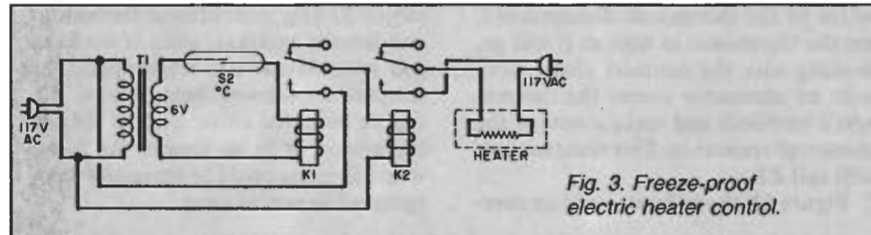

Fig. 3. Freeze-proof electric heater control.

PARTS LIST (Fig. 3)

- | | |
|---|---|
| K1—6-V ac (12 ohms or more) relay, 5-A normally open contacts (Potter & Brumfield KA5AY-6VAC or equivalent) | S2—Freeze sensor (MCI TS-5B19. See Parts List for Fig. 1) |
| K2—120-V ac power relay, 15-A contacts (Potter & Brumfield PRD1AYO-120VAC or equivalent) | T1—6.3-V ac transformer |
| | Misc.—Electric heater (see text), electric plug, # 14 wire, solder screws, etc. |

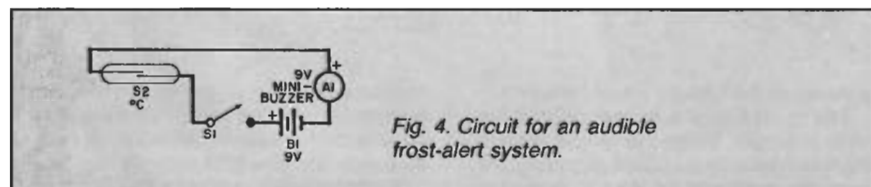
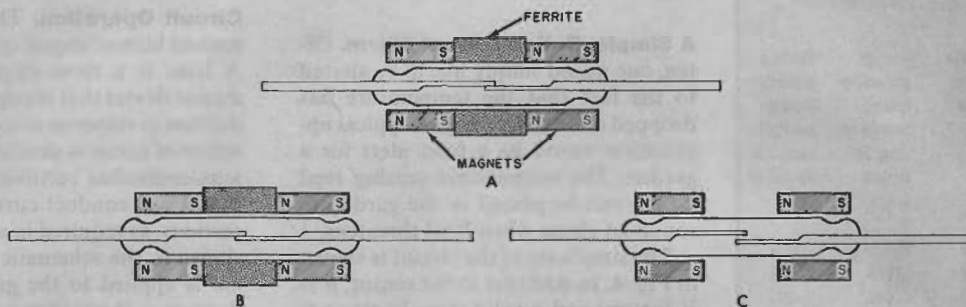

Fig. 4. Circuit for an audible frost-alert system.

PARTS LIST (Fig. 4)

- | | |
|---|--|
| A1—9-V solid-state mini-buzzer (Sonalert) | S1—Spst switch (optional) |
| B1—9-V battery | S2—Freeze sensor (MCI TS-5B19L. See Parts List for Fig. 1) |

HOW A TEMPERATURE-SENSING REED SWITCH WORKS



A temperature-sensing reed switch consists of a rhodium-contact reed switch hermetically sealed in glass, two permanent magnets that surround the glass, and a ferrite ring sandwiched between the magnets (Fig. A). The switch depends on the interaction of the magnets and the ferrite for its operation.

The ferrite ring is the temperature-sensing component of the device. It is magnetic below its *Curie temperature* but non-magnetic above it. (The Curie temperature of a ferrite material is the temperature above which the ferrite's ability to conduct flux is severely reduced.) To get some idea of how temperature affects the sensor, refer to Fig. B. Here the temperature is below the ferrite's Curie temperature and thus the ferrite is magnetic. Notice how the magnetic flux lines travel easily through the ferrite. Since the ferrite is magnetic, the magnetic field in the area of the contacts is sufficient in strength to keep them closed.

Now assume the sensor is heated so that the ferrite exceeds its Curie temperature (Fig. C). The warmed-up ferrite is now nonmagnetic and its reluctance increases dramatically. Because of its high reluctance, the ferrite cannot easily conduct lines of flux. This results in a reduction in magnetic field strength near the reed switch's contacts. Since the magnetic force holding the contacts closed has now weakened substantially, the contacts open. (Note that since the ferrite is now nonmagnetic, it is eliminated from the drawing.) When the ferrite cools to below its Curie temperature, it becomes magnetic again. The magnetic field increases, so the contacts close once again.

The freeze sensor we are particularly interested in is the TS-5B19 manufactured by Midwest Components, Inc. (Muskegon, MI). It is a temperature-sensing reed

switch that operates at temperatures below 125°C (257°F).

Though the switches are used primarily as freeze sensors here, the ferrite material can have a wide range of Curie temperatures from -10°C to 250°C.

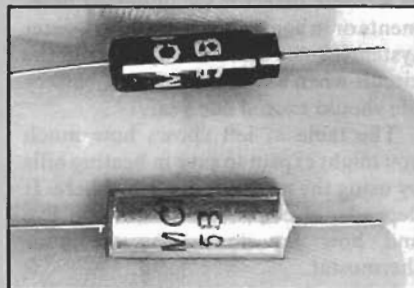

Temperature-sensing reed switches.

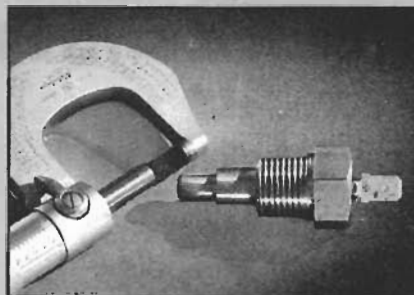

Metal-packaged freeze sensor.

switch with ferrite material that has a Curie temperature of approximately 39°F. These sensors come in metal or plastic packages. The metal-packaged sensor can withstand temperatures as high as 400°C (750°F), while the less-expensive plastic-packaged model is limited to use with tem-

peratures below 125°C (257°F). Though the switches are used primarily as freeze sensors here, the ferrite material can have a wide range of Curie temperatures from -10°C to 250°C.

Characteristics of the TS-5B19. Most factory-run TS-5B19's have a trip point near 39°F. MCI guarantees that all TS-5B19's will close their contacts before the temperature drops to 1°C (33.8°F) and will not close before 7°C (44.6°F). Note that all trip points assume falling temperatures. The rising temperature trip point is several degrees higher.

The TS-5B19 series of sensors have contacts rated at 10 W or 12 VA maximum. Maximum voltage is 100 V dc or 120 V ac. The contacts can carry up to 1 A but have only a ½-A "make" rating. The maximum recommended operating temperature is 257°F.

All temperature-sensing reed switches are magnetic in nature. Because of this, some precaution should be taken when locating most kinds, including the freeze sensor. The switches should be kept at least ½" from any iron or steel and at least ¾" from any magnetic-field producing device (i.e. magnet, transformer, motor, solenoid, similar sensors, etc.). It is also recommended that the leads not be cut. However, bending is okay. If these precautions aren't followed, the trip point will be changed.

The sensors are completely waterproof. Additionally, gasoline, motor oil, calcium chloride, or Freon has no effect on them. However, alcohol, strong sulfuric acid, and some other chemicals will destroy plastic-packaged models.

A Freeze-Proof Room. Some people have a small storage building or small room in an unheated garage that is unsuitable for storing items that must be kept from freezing. Also, some utility rooms or even half-baths are left unheated to economize. On a bitter cold night, this can lead to frozen and cracked pipes and other problems. If

the area is sufficiently insulated and relatively small, it can be kept freeze-proof quite economically by using a 120-V, U.L. electric heater in conjunction with a control like the one shown in Fig. 3. This control is also suitable for keeping a small greenhouse frost-free.

In Fig. 3, *T1* is an inexpensive 6.3-V ac filament transformer typically avail-

able from surplus electronics stores. Relay *K1* has normally open contacts rated at 5 A and its coil is rated at 6 V, 500 mA ac (or less). Relay *K2* can be any 120-V ac power relay that has contacts rated at 15 A or more. Be sure to use #14 U.L. wire in this circuit. This type of circuit, with some modifications (such as replacing *K2* with a heavy-

ENERGY SAVING AROUND THE COUNTRY

	Average heating degree days	Average wintertime heating savings by using 38°F instead of 54°F	Average wintertime heating savings by using 38°F instead of 68°F
NORTHEAST			
Boston	6000	40-45%	80-90%
Cleveland	6154	40-45%	80-90%
New York	5000	45-50%	85-95%
NORTH CENTRAL			
Chicago	6300	40-45%	80-85%
Detroit	6325	40-45%	80-85%
Minneapolis	8310	35-40%	60-65%
MIDSOUTH			
Louisville	4640	45-50%	85-95%
St. Louis	4750	45-50%	90-95%
Washington, DC	4211	45-55%	90-95%
SOUTH			
Atlanta	3095	50-100%	90-100%
Dallas	2290	55-100%	90-100%
Memphis	3227	45-95%	90-95%
WEST			
Albuquerque	4292	45-50%	90-95%
Anchorage	10,911	30-35%	50-60%
Salt Lake City	5983	40-45%	80-90%
Seattle	5185	45-100%	85-100%
Spokane	6835	40-45%	80-85%

duty relay that has dpst contacts), can be used to control a 240-V ac electric heater.

A Simple, Reliable Frost Alarm. Often, one would simply like to be alerted to the fact that the temperature has dropped close to freezing. A typical application would be a frost alert for a garden. The temperature-sensing reed switch can be placed in the garden to sound an alarm when frost threatens.

The simplicity of the circuit is shown in Fig. 4. In addition to the sensor, a 9-V battery and a solid-state buzzer are all that are required. Switch *S1* is optional. Locate the sensor as close as possible to the plants you want to protect. The sensor can simply be set on the ground, if desired.

Another possible use of this circuit is as a freeze detector for unheated basements or in some simple solar hot-water systems. Since current only flows in the circuit when a freeze threatens, battery life should exceed one year.

The table at left shows how much you might expect to save in heating bills by using the methods described here. It depends, of course, on where you live and how far down you set your thermostat. ◇

tor control and continuous air circulation to your warm-air heating system.

Circuit Operation. The heart of the revised blower-motor control is a triac. A triac is a three-electrode semiconductor device that is triggered into conduction in response to a gate signal. The action of a triac is similar to that of a silicon-controlled rectifier (SCR), except that it can conduct current in both directions, as required in an ac circuit. As shown in the schematic (Fig. 1), a signal is applied to the gate of the triac through a thermister and diac *D2*. (A diac is a solid-state trigger device that has a breakdown voltage similar to that of a zener diode, except that it works in either direction.)

An RC time constant composed of thermistor *TCR1* and capacitor *C4* prevents the triac from delivering power to the motor for part of each half cycle of the 117-V ac waveform. When plenum temperature is low, *TCR1* has a high resistance. This lengthens the time required for the voltage to increase sufficiently to trigger the triac into conduction through *D2*. When plenum temperature is high, the triac is triggered into conduction earlier in the cycle, resulting in more power being delivered to the motor and higher operating speed.

A second trigger circuit, composed of *R2*, *C3*, and diac *D1*, is used to ensure that the motor operates at a minimum speed regardless of the temperature (and resistance) of the thermistor. A minimum blower speed is necessary since the furnace cannot operate with a blower turning too slow or not at all.

For heating and cooling systems, an optional switch has been included in the circuit so that the proportional motor control can be overridden during the cooling season. The switch provides sufficient gate signal to the triac to ensure maximum blower-motor speed.

Components *R1*, *C1*, *C2*, and *L1* are included in the circuit to smooth the steep wavefronts generated by the triac and help reduce radio-frequency interference, which is inherently produced in switching circuits such as this.

Construction. The circuit can be constructed on a small printed-circuit board measuring about 3" by 3". The only external components are the thermistor and optional switch *S1*. Figure 2 shows a full-size foil pattern, and Fig. 3 shows the parts layout.

Since this circuit is powered directly from the ac power line, all capacitors



Triac Motor Control for Warm-Air Systems Reduces Fuel Use and Eliminates Cool Spots

by Anthony Caristi

DOES the blower motor of your warm-air heating system have just one speed? If so, your furnace is not operating at optimum efficiency. In a warm-air heating system, the air should move through the heat exchanger of the furnace at a velocity that continuously varies with the temperature of the plenum.

Another shortcoming of your warm-air heating system as it is designed might be that the blower motor shuts off at times. Since a warm-air system

has no inertia, you may feel a chill when the blower stops even though the room temperature is high enough to trip the thermostat and turn the burner off. Nowadays, warm-air systems are designed with a "continuous air circulation" feature. This means that the burner cycles on and off frequently, keeping the plenum warm enough to maintain continuous blower operation.

With the inexpensive and easy-to-build circuit described here, you can add both a variable-speed blower-mo-

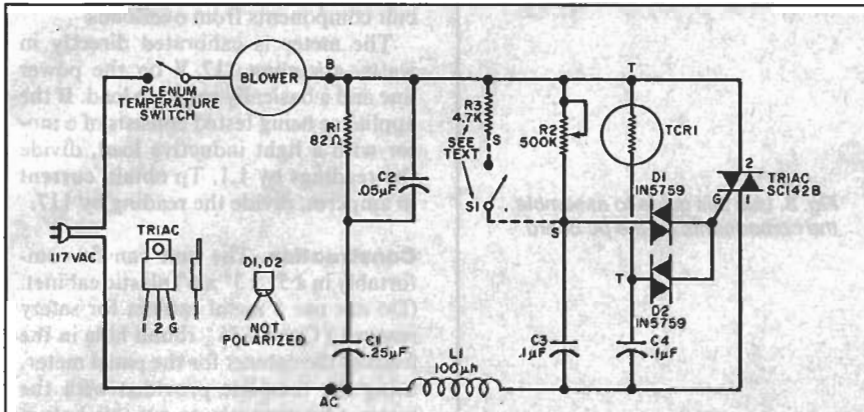

Fig. 1. The blower-motor control circuit is based on the use of a triac.

PARTS LIST

C1—0.25- μ F, 200-V tubular capacitor
 C2—0.05- μ F, 200-V tubular capacitor
 C3,C4—0.1- μ F, 200-V tubular or disc capacitor
 D1,D2—1N5758 diac or equivalent
 L1—100- μ H, 5-A choke (see text)
 R1—82-ohm, 1/4-W, 10% composition resistor
 R2—500-kilohm, pc-mount potentiometer
 R3—4.7-kilohm, 1/4-W, 10% composition resistor

S1—Spst switch
 TCR1—200-kilohm at 25°C thermistor (Keystone Part No. RL 1004-104550-155-D1 or equivalent)
 Triac—SC142B or similar
Note: The following are available from Anthony Caristi, 69 White Pond Rd., Waldwick, NJ 07463: pc board at \$3.50; triac at \$3.50; diacs at \$2.00 each; thermistor at \$5.00. Please include \$0.50 for postage.

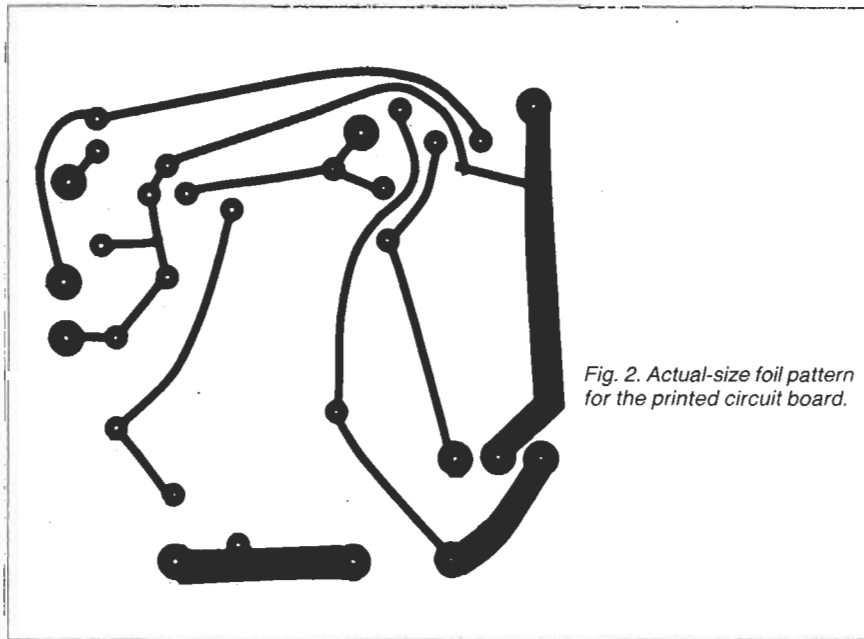

Fig. 2. Actual-size foil pattern for the printed circuit board.

to the printed circuit board with a #4 machine screw and nut. Use heat sink compound between the mounting tab of the triac and the heat sink for best heat conduction. Be sure to keep the heat sink completely insulated from any metal part of the furnace when installing the pc board.

Inductor *L1* can be easily constructed by winding about 15 turns of #20 enamel wire on a wood or plastic 3/8"-diameter form. The inductance of *L1* is not critical, but do not use wire of smaller gauge since *L1* must be able to carry the full load current of the blower motor without overheating. The same caution applies to the foil pattern which is shown in Fig. 2. Be sure to keep the conductive paths to the triac wide (as illustrated).

The pc board can be mounted inside the furnace where the other electrical controls are located. The schematic diagram and printed-circuit layout are marked with the letters AC, B, S, and T, which will help you identify connections to the external parts of the circuit.

Run a pair of wires for the thermistor from the "T" terminals on the pc board up to a convenient place on the plenum where the thermistor can readily sense temperature changes. Drill a small hole in the plenum sheet metal to insert the thermistor so that the air flow will pass over it. Be sure to insulate the thermistor and its connections so that no possible short-circuit to the metal parts of the furnace can occur.

If this should happen, the pc board or its components could be destroyed. Do not cover the head of the thermistor with insulation, since this will tend to make the component less sensitive to the changing temperature of the plenum.

Checkout and Adjustment. Before applying power to the furnace, check all connections to make sure the wiring is correct. To set the minimum blower speed, temporarily turn on the furnace by manually adjusting the plenum temperature switch or connecting a jumper across the switch to complete the circuit. (This must be done while the plenum is cool. If necessary, run the blower with the gas or oil burner off until the plenum is cool to the touch.) Then adjust *R2* for the minimum desired blower speed.

Now reset the plenum switch back to its original position (which should be somewhere between 90° and 110° F), or remove the temporary jumper. Set the room thermostat so that it calls for

must have at least a 200-V rating. Do not use low-voltage types designed for solid-state circuits.

The blower motor will draw several amperes through the triac during operation, which will result in some power being dissipated in the device. It is rec-

ommended that a small heat sink be used to help keep the triac from overheating. A simple heatsink can be constructed by bending a 1" by 3" piece of sheet aluminum into a U shape. Drill a hole through the center of the aluminum and mount the triac and heatsink

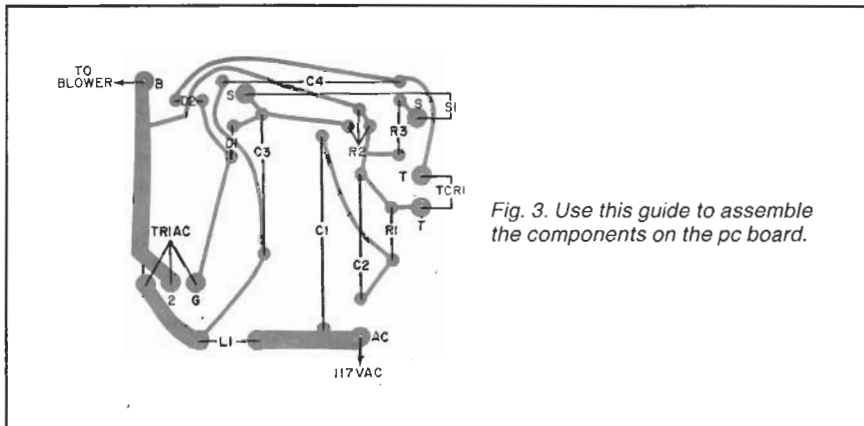

Fig. 3. Use this guide to assemble the components on the pc board.

cuit components from overloads.

The meter is calibrated directly in watts, assuming 117 V on the power line and a basically resistive load. If the appliance being tested consists of a motor with a light inductive load, divide the readings by 1.1. To obtain current in amperes, divide the reading by 117.

Construction. The unit can fit comfortably in a 5" x 3" x 6" plastic cabinet. (Do not use a metal cabinet for safety reasons.) Cut a 1 7/8" round hole in the front of the cabinet for the panel meter, using the template provided with the meter. (An easy way to cut this hole is with a nibbler tool.) Then cut another hole in the front for switch S1 and three holes in the back of the cabinet for sockets SO1, SO2, and the ac power cable. Put a rubber grommet into the hole to protect the cable insulation. Then install two tie-down terminal strips. Keep all resistors away from cabinet walls as the resistors may get hot.

The next step is to pry off the front cover of the panel meter and replace the dial. Remove the two Phillips screws and dial, being careful not to damage the pointer. Cut the new dial from Fig. 1 and glue it over the old dial. Then reassemble the panel meter. Wire the resistors and zener diodes as shown in Fig. 2.

Setup and Use. Plug the Power Meter into an outlet. There should not be any reading. If you know the approximate power rating (wattage) of the appliance you are going to test, plug it in the appropriate socket, SO1 or SO2. If you don't know the approximate power rating of the appliance, always start with SO1 (250-1100 W).

If you get a low (or no) reading, plug the appliance into SO2 (60-250 W). If you still get a low (or no) reading, depress S1 for the most sensitive range (15-60 W). Failure to follow these instructions can result in damage to the Power Meter.

After you take the reading, remove the Power Meter from the circuit and plug the appliance directly into the outlet. Remember, the range of the meter is approximately 15 to 1100 W. It should not be used with appliances such as air conditioners, large electric stoves, or dryers that draw more than the maximum current.

Estimating Electricity Cost. You can estimate how much it costs to run a particular appliance like a tube-type color TV set by using the following

heat. Now, as the furnace heats up and the blower comes on, the blower speed will automatically increase as the plenum temperature rises. Conversely, when the thermostat shuts the burner off, the blower speed will decrease as the plenum cools.

Ideally, the blower will continue to operate at minimum speed until the thermostat turns the burner on again. This continuous air circulation will greatly enhance the comfort level of your home, and will help you conserve heating fuel too. ◇



Power Meter Keeps Tabs of How Much Electricity an Appliance Uses

by Cass Lewart

WITH electrical and electronic products abounding in homes and electric power costs so high, it would be interesting and valuable to know how much power each one consumes. The inexpensive power meter described here enables you to accurately determine ac electric consumption for appliances rated between 15 and 1100 watts. It can also be used for diagnostic work when repairing appliances.

Circuit Operation. The current in the appliance under test passes through resistors R1 and R5, R6 and R7, or R1 through R5, depending on which of three ranges is selected. A voltage drop of up to 2 V ac across the resistors operates panel meter M1. (The meter has a built-in rectifier.) Two zener diodes, D1 and D2, and resistors R8 and R9 protect the meter from overload. Optional fuses F1 and F2 further protect the cir-

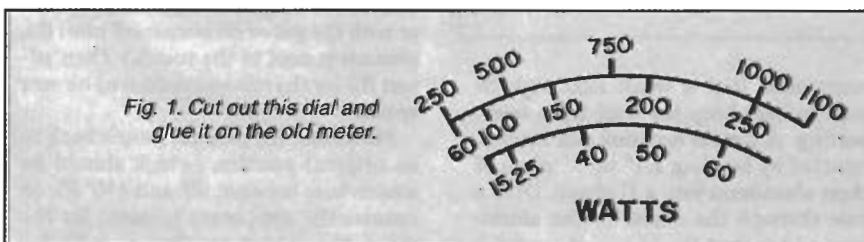

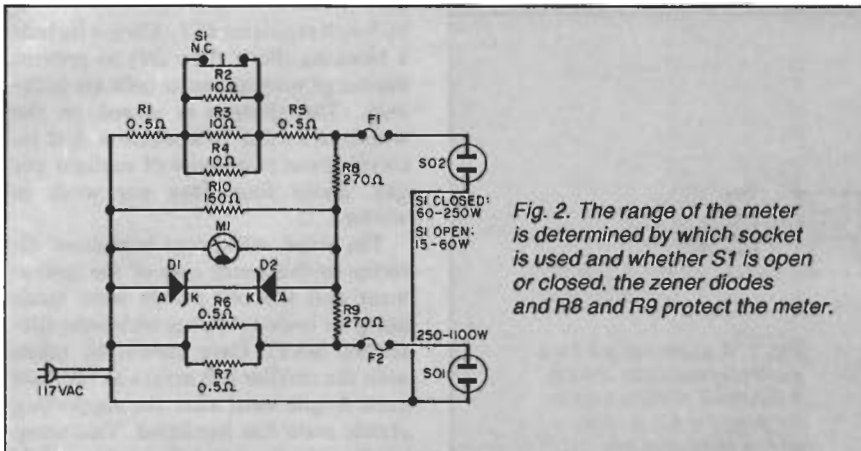

Fig. 2. The range of the meter is determined by which socket is used and whether S1 is open or closed. The zener diodes and R8 and R9 protect the meter.

PARTS LIST

- | | |
|---|--|
| D1, D2—4-V zener diode | R8, R9—270-ohm, 1/2-W resistor |
| F1—5-A fuse (optional) | R10—150-ohm, 1/2-W resistor |
| F2—15-A fuse (optional) | S1—Spst normally closed, pushbutton switch, 3-A rating or better |
| M1—VU meter (Calectro D1-930 or equivalent, see text) | SO1, SO2—117-V jack |
| R1, R5, R6, R7—0.5-ohm, 10-W resistor | Misc.—Hardware, plastic cabinet, wire solder, etc. |
| R2, R3, R4—10-ohm, 1/2-W resistor | |

method. First determine how much electricity the TV set uses with the Power Meter (approximately 350 W). Next, check the cost of electricity in your area (in a typical residential area like northern New Jersey, cost is currently \$0.09 per kilowatt-hour). Then

estimate the time of operation. If the set were used for six hours each day, the cost of electricity could be calculated as shown here.

$$\begin{aligned} &350 \text{ W} \times 6 \text{ hr/day} \\ &\times 30 \text{ days/mo} \times \$0.09/1000 \text{ W-hr} \\ &= \$5.67/\text{mo.} \quad \diamond \end{aligned}$$



How to Use Solar Energy to Recharge Your Batteries

by Ed Karns

THE prices of photovoltaic cells, commonly called solar cells, are dropping to the point where experimenters can start exploring solar-power applications.

Since solar cells generate power only when illuminated, they are popularly used to charge batteries. Such solar-

powered battery chargers are easy to make. You can get started quickly in this energy-related area with the four simple designs presented here. Although some of the designs illustrated were developed for use with radio-controlled model airplanes, they can be used for many other solar chargers.

Basic Power. The circuit shown in Fig. 1 was used to charge a nominal 9.6-volt battery to power a radio-controlled (RC) transmitter. The "rule-of-thumb" is that the number of solar cells to use is equal to the required battery voltage divided by 0.4. (The typical voltage that most solar cells generate in sunlight is 0.45 V, with 0.4 chosen here to provide a design cushion.) The current requirement of the cells should be sufficient to charge the battery. Thus, in this application, 24 cells were used (9.6/0.4).

When the voltage across the solar array shown is greater than the battery voltage, diode *D1* is forward-biased, allowing current to flow to the battery. However, if the battery voltage is higher than that of the solar array (due to a passing cloud, etc.), diode *D1* is reverse-biased and acts as an open switch to protect the array. Since the voltage drop across *D1* is 0.7 V (typical for a silicon diode), it is less than 10% of the total voltage and its effect can be ignored.

The current capacity of a solar array is determined by the required load current, the amount of time the load is used, and the length of time the array is exposed to light.

Since a solar cell delivers its maximum power in bright sunlight, the effects of cloudy or hazy days must be compensated for. Since the charging rate for the battery used in Fig. 1 was about 90 mA, the solar array was designed to deliver more current to account for the dark intervals. This is why the author elected to use 150-mA solar cells.

Depending on the brightness of the sunlight, the solar array can deliver 12 or more volts (at reduced current). Since a NiCd battery "likes" to be charged to at least 1.35 V per cell, and there are eight cells in the 9.6-volt battery used, the total voltage applied to the battery should be limited to 10.8 volts (1.35 × 8). Zener diode *D3* was selected to keep the supplied voltage to 11 volts (the closest zener to 10.8 volts). The voltage drop across silicon diode *D1* is the same as that across *D2*, so that the voltage drop across *D3* is equal to the maximum voltage across the battery. Since the load may not always be plugged into the solar array, zener *D3* should be capable of dissipating all the array power without destructing. This is why a 5-watt zener is used in this 1-watt circuit.

The circuit shown in Fig. 2 was designed so that the array could be mounted inside the wings of an RC airplane, with a "transparent" covering.

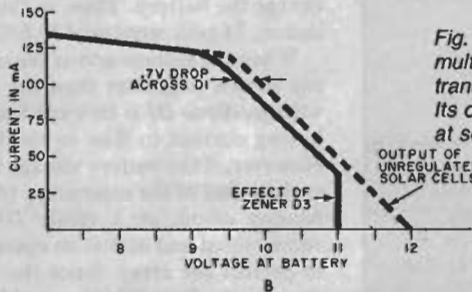
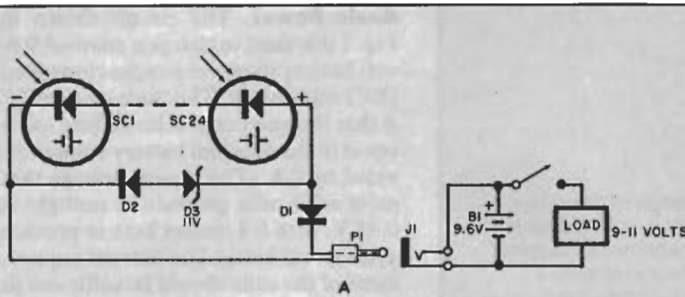

Fig. 1. A solar charger for a multi-channel radio control transmitter is shown above. Its output in full sunlight at sea level is at left.

PARTS LIST (Fig. 1)

F1—9.6-V rechargeable battery
 D1, D2—IN4001 diode (or similar)
 D3—11-V, 5-W zener diode (SK3392 or similar)
 J1—Miniature connector
 P1—Miniature plug
 SC1-SC24—150-mA, edge-cut solar cell
Note: The following is available from

Departure Co., 339 Myrtle Ave., Cotati, CA 94928; complete kit of parts including solar cells, diodes, hookup wire, solder, etc. (No. 150-10) at \$65. Also available separately are individual 150-mA solar cells (No. 150-1) at \$2.10 each. California residents, add 6% sales tax. For UPS shipment in US, add \$3.

To maintain balance, the array was divided in half, with one half in each wing. The battery had to handle the RC receiver and the servos used to control the airplane.

In this particular application, the load (receiver and servos) was about 50 mA when the servos are idle (about 80% of the time), reaching about 300 mA when two or three servos are operating. We estimated an average drain of about 120 mA from the battery. When this amount is added to the losses due to the "transparent" array covering (estimated at 20 mA), and the misorientation of the arrays with the sun (estimated at 20 mA), the total becomes about 160 mA. Since there is always the possibility of extensive cloud cover, coupled with the fact that we do not like to crash an expensive RC plane due to lack of control, we elected to overspecify the solar array by 100%, with the closest cells having a 300-mA capacity.

Note that blocking diode *D1*'s voltage drop of 0.7-volt is almost 20% of the 4.8-volt battery voltage and must be compensated for in the voltage portion of the array. Since 4.8 volts requires 12

solar cells (4.8/0.4), to compensate for the *D1* drop, 14 cells (5.6 volts) were used, seven on each side. Note that the array voltage can exceed 7 volts depending on light level and loading. Zener diode *D5* coupled with diodes *D2*, *D3*, and *D4* limit the array voltage to a maximum of 6.4 V (4.3 + 0.7 + 0.7 + 0.7). When the *D1* drop is accounted for, 5.7 V reaches the battery. *LED1*, connected across the three silicon diodes is optional, and indicates when the arrays are delivering their rated power. The voltage drop across *D2*, *D3*, and *D4* (all silicon diodes) is 2.1 V, enough to operate the LED.

Regulated Power. The circuit in Fig. 3 shows the ability of a low-power (50-mA cells) solar charger to do a large job. The load was a digital meter having a 750-mA current requirement. Since the device is used only about once every other day (at most), and then for less than five minutes, the 50-mA solar array is adequate.

Note the absence of a zener diode. The battery is allowed to float up to about 14.5 V since the load is protected

by 5-volt regulator *IC1*. Always include a blocking diode (like *D1*) to prevent discharge when the solar cells are in the dark. The charger is placed on the workbench close to a window, and receives about two hours of sunlight per day, about four days per week in winter.

The solar cells were laminated directly to the metal case of the instrument and the cell arrays were made using an oven-soldering technique (described later). Care should be taken with the smaller cell arrays as they are quite fragile until after the supporting plastic resin has hardened. This setup has been in operation for quite a while without resorting to a line-powered charger.

The circuit shown in Fig. 4 uses 600-mA solar cells and was designed for a small (28-foot) sailboat that spends its winter moored in the bay and thus requires marker lights. This charger provides enough power to operate the lights and a small electrical bilge pump. The boat goes for weeks before the auxiliary engine is required to fully charge the battery.

Diode *D1* and fuse *F1* prevent the destruction of *LED1* and the solar array in the event of accidental polarity reversal (as in the case of "jump-starting" the engine or other odd circumstances). When all is correct, *LED1* will glow steadily, going out only when the battery is under a heavy load or in the event of a short in the boat's electrical system.

The solar cells should be laminated to marine plywood, making the charger corrosion-resistant and quite strong mechanically. Scratches are repaired by painting on a little plastic resin. Extra solar cells (36, instead of 30 or 32) are used because the charger was intended to be mounted flat on the cabin roof instead of tilted up into the sun, to insure sufficient output even on partly cloudy days and in the winter. No maintenance is required except periodically washing off the salt deposits and adding distilled water to the battery. *PS1* is a weatherproof photoswitch that applies power to marker lamps *L1* and *L2* when it gets dark.

An excellent trickle charger for automotive 12-V batteries can be made by using thirty 150-mA solar cells with a voltage-regulator circuit such as that shown in Fig. 4. The entire solar array can be made into a square about 8" on a side and about 3/4" thick, using 3/8" plywood, #16 (or heavier) leads, and large alligator clips (paint the positive one

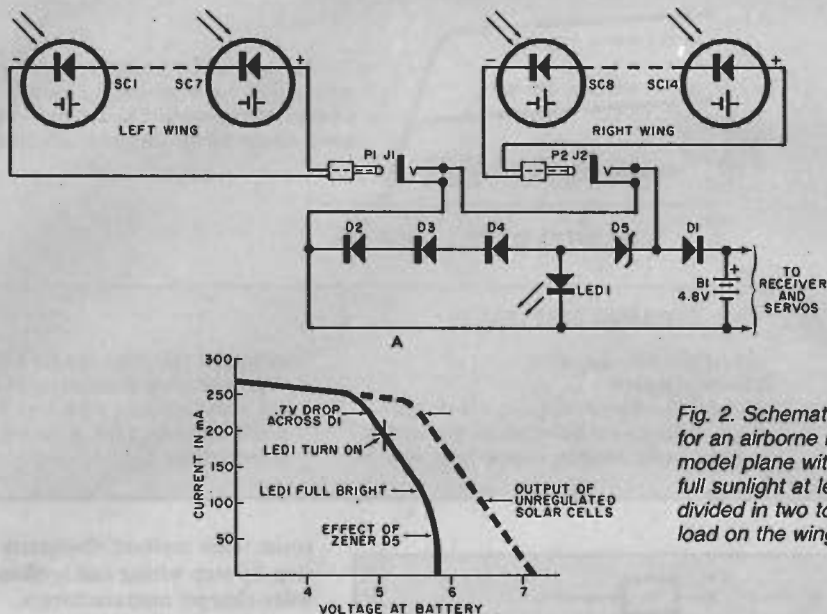

Fig. 2. Schematic of a solar charger for an airborne radio-control model plane with its output in full sunlight at left. The array is divided in two to balance the load on the wings of the plane.

PARTS LIST (Fig. 2)

B1—4.8-V rechargeable battery
 D1-D4—1N4001 diode (or similar)
 D5—4.3-V, 5-W zener diode (SK3380 or similar)
 J1, J2—Miniature connector
 LED1—20-mA red light emitting diode
 P1, P2—Miniature plug

SC1-SC14—300-mA solar cells
Note: A complete kit of parts, including solar cells, diodes, LED, etc., is available (No. 300-5) for \$85. Also available separately is the 300-mA solar cell (No. 300-1) at \$5.80 each. See Fig. 1 for ordering information.

red). A fully charged lead-acid battery will survive -50°F without freezing. This is an important consideration for vehicles left outdoors and unused for long periods during the winter.

The trickle charger will bring a low auto battery up to a full charge with about eight hours of full sun and will not interfere with automotive voltage-regulation circuits.

Acquiring Solar Cells. A great many mail-order houses have solar cells in their catalogs. Some of these cells are factory-fresh, others are edge cuts left over when square cells are cut from round silicon wafers, and still others are rejects that do not deliver 100% of their rated power. Real bargains are available, but it is a good idea to always test every cell. A 100-W light bulb, placed 6 to 8 inches above a cell, should generate 0.45 to 0.52 V and at least 25% of the cell's rated current.

Unless you intend to provide a solid mount for your cell arrays, try to avoid cells that are mechanically weak. Also, stick to blue/gray cells, as these have an

anti-reflective coating and will generate power even when the sun is close to the horizon (high incidence angle).

Examine the grid pattern on the sensitive surface of the cells, and look for a lot of small grid lines that radiate out from a common point or common bus. The less efficient cells have only three or four thick grid lines.

Avoid cells without a solder plating on the rear. Broken solar cells can be repaired, but it requires patience and a steady hand.

Construction Hints. Solar cells are manufactured in high-temperature ovens, so they are not bothered by soldering-iron temperatures. Use irons of 25 to 60 W, and don't press down on the delicate cells. Soldering on the back (positive contact) is usually only a matter of applying enough heat to make a shiny solder puddle, not a dull, gray blob. Solder time is usually about 10 seconds, although reheating is no problem.

Soldering on the grid pattern of the active side (negative contact) can

present some difficulties. Try to avoid reheating a grid line more than two or three times as the exotic metals in the grid can flow into the solder and away from the cell. Perform all soldering operations on a piece of white paper as the hot cells can pick up dirt that might not come off after cooling.

Some solar cells lend themselves nicely to the oven soldering technique. The 50-, 100-, and 150-mA cells are ideal for this. Deposit a small drop of solder at the point of contact on the back side, and a small solder trail on the main grid line on the front. Arrange a group of 6, 8, or 10 cells in the bottom of a Pyrex cake dish so they overlap at the points of contact. Then put the dish in a household kitchen oven (not a microwave), set at 500 to 550°F, and allow it to "bake" for about 20 minutes.

The solder will reflow and make a very good electrical and mechanical connection. Let the dish and solar array cool down before removal from the oven in case the solder is still liquid. If the cell array sticks to the dish, use a little alcohol or acetone to dissolve the

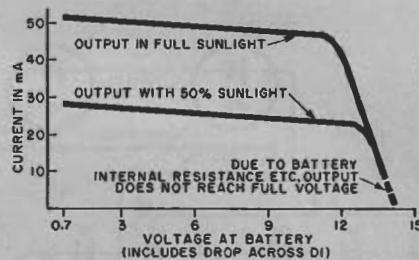
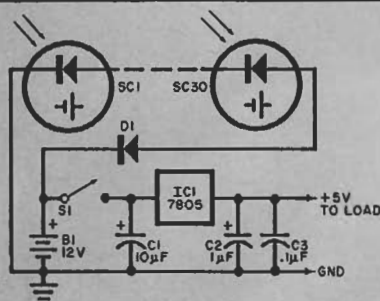

Fig. 3. Using a low-power solar charger on a digital meter having a 750-mA current requirement. The device is seldom used so the 50-mA output is adequate.

PARTS LIST (Fig. 3)

B1—12-V rechargeable battery
C1—10- μ F, 25-V electrolytic
C2—1- μ F, 10-V electrolytic
C3—0.1- μ F, disc capacitor
D1—1N4001 diode (or similar)

IC1—7805 5-V regulator
S1—Spst switch
SC1-SC30—50-mA, edge-cut solar cell
Note: A complete kit of parts, including solar cells, diodes, capacitors, etc., is

available (No. 050-12) for \$37.50. Also available separately is the 50-mA solar cell (No. 050-1) at \$1.10 each. See Fig. 1 for ordering information.

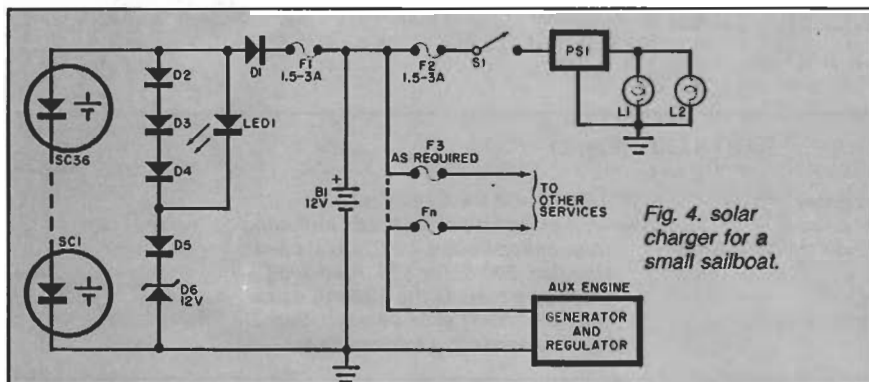

Fig. 4. solar charger for a small sailboat.

PARTS LIST (Fig. 4)

B1—12-V deep-cycle marine battery
D1-D5—1N4005 diode (or similar)
D6—12-V, 50-W zener diode (ECG5254 or similar)
F1, F2—1.5-to-3-A fuse
LED1—20-mA red light emitting diode
PS1—Weatherproof photo switch for 12-V system

S1—Spst switch
SC1-SC36—600-mA solar cells
Note: A complete kit of parts, including solar cells, diode, LED, etc., is available (No. 600-12M) at \$385. Also available separately is the 600-mA solar cell (No. 600-1) at \$10.60 each. See Fig. 1 for ordering information.

rosin. This method eliminates a lot of step-by-step wiring and is often used by solar-charger manufacturers.

Testing Solar Arrays. The test circuit shown in Fig. 5 can be used with groups of five to 500 cells, and current outputs of 10 mA to 1 A. LED1 will glow when any group of five or more cells are positioned 6" to 8" from a 100-W light bulb. The diodes bypass everything over about 2.1 V so LED1 is properly biased. The solar cell arrays are inherently short-circuit protected, so the only limiting factor is the ability of the diodes to pass current. For cell arrays with outputs up to 3 A, use 1N1056 or 1N1226 diodes, or similar.

Mounting Solar Cells. Cells should be positioned by laminating the groups of tested cells to anything relatively rigid, such as 3/8" plywood or 3/64" aluminum sheet. Give the surface a couple of thick coats of clear plastic resin (clear fiberglass resin is available at hobby, boat, or auto-body shops), and allow to set.

Then add a third coat. While it is still wet, fit the assembled and tested solar cell array in place. Finally, paint on three or more coats of plastic resin to completely encapsulate the cells, hook-up wire, diodes, and LED. This makes the entire package corrosion-resistant. If you are mounting onto metal, the plastic will insulate the cells.

There are many companies that make available silicon photovoltaic cells for solar-power use, including Radio Shack and Edmund Scientific (Barrington, NJ). Also, the parts list includes a supply source for parts used in the projects presented here. \diamond

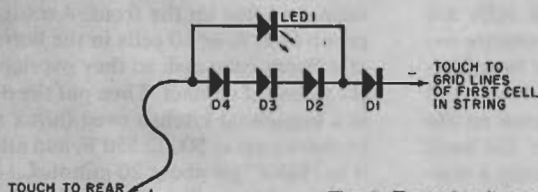

Fig. 5. Test circuit can be used with groups of five to 500 cells and outputs of 10 mA to 1A.

PARTS LIST (Fig. 5)

D1-D4—1N4001 diode (or similar) LED1—20-mA red light emitting diode