

WHITE

**Sewing Machines
Parts Catalogue and
Service Manual**

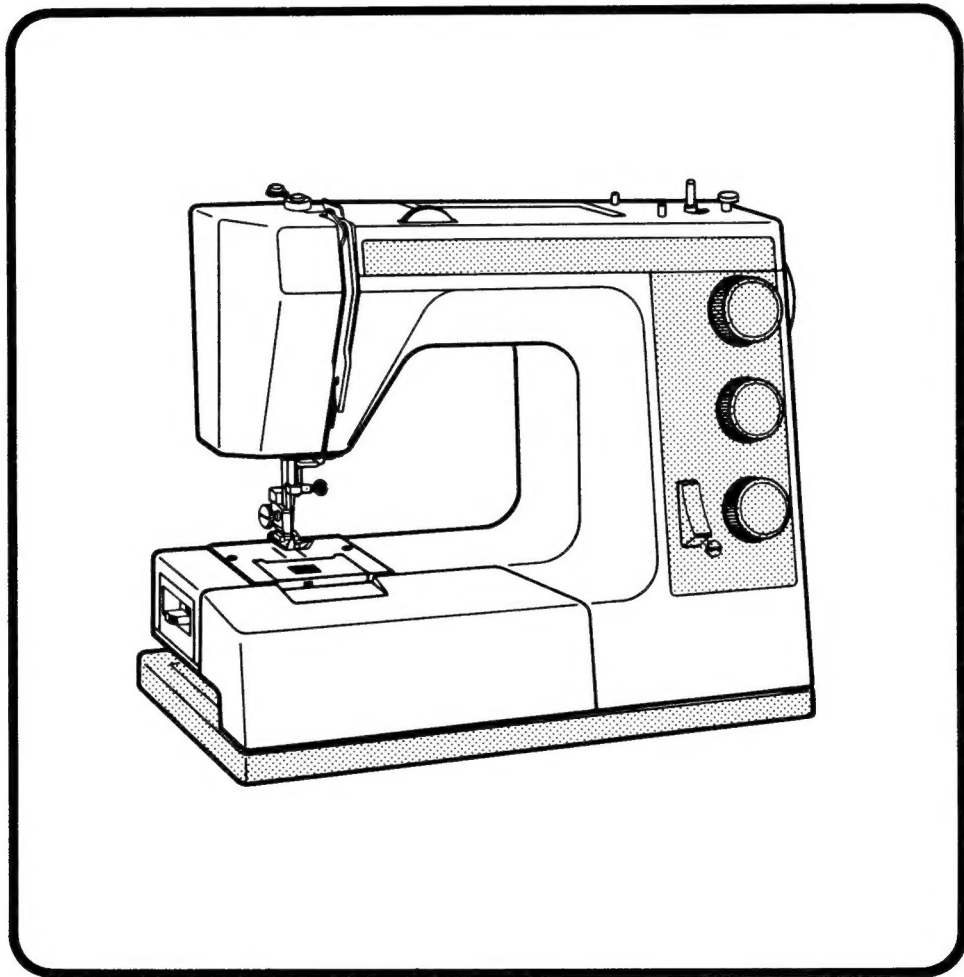

Model 2000 Series

CONTENTS

1. Machine Body Component Parts.....	1
2. Upper Thread Presser Bar Parts	3
3. Upper Shaft, Lower Shaft Parts.....	5
4. Needle Bar Parts	7
5. Hook Assembly Parts.....	9
6. Feed Regulating Parts.....	11
7. Feed Regulating Parts	13
8. Zigzag Generating Parts.....	15
9. Pattern Selecting Parts	17
10. Specific Parts — ①	19
11. Specific Parts — ②	21
12. Accessories.....	23
13. Service Manual.....	25

1. Machine Body Component Parts

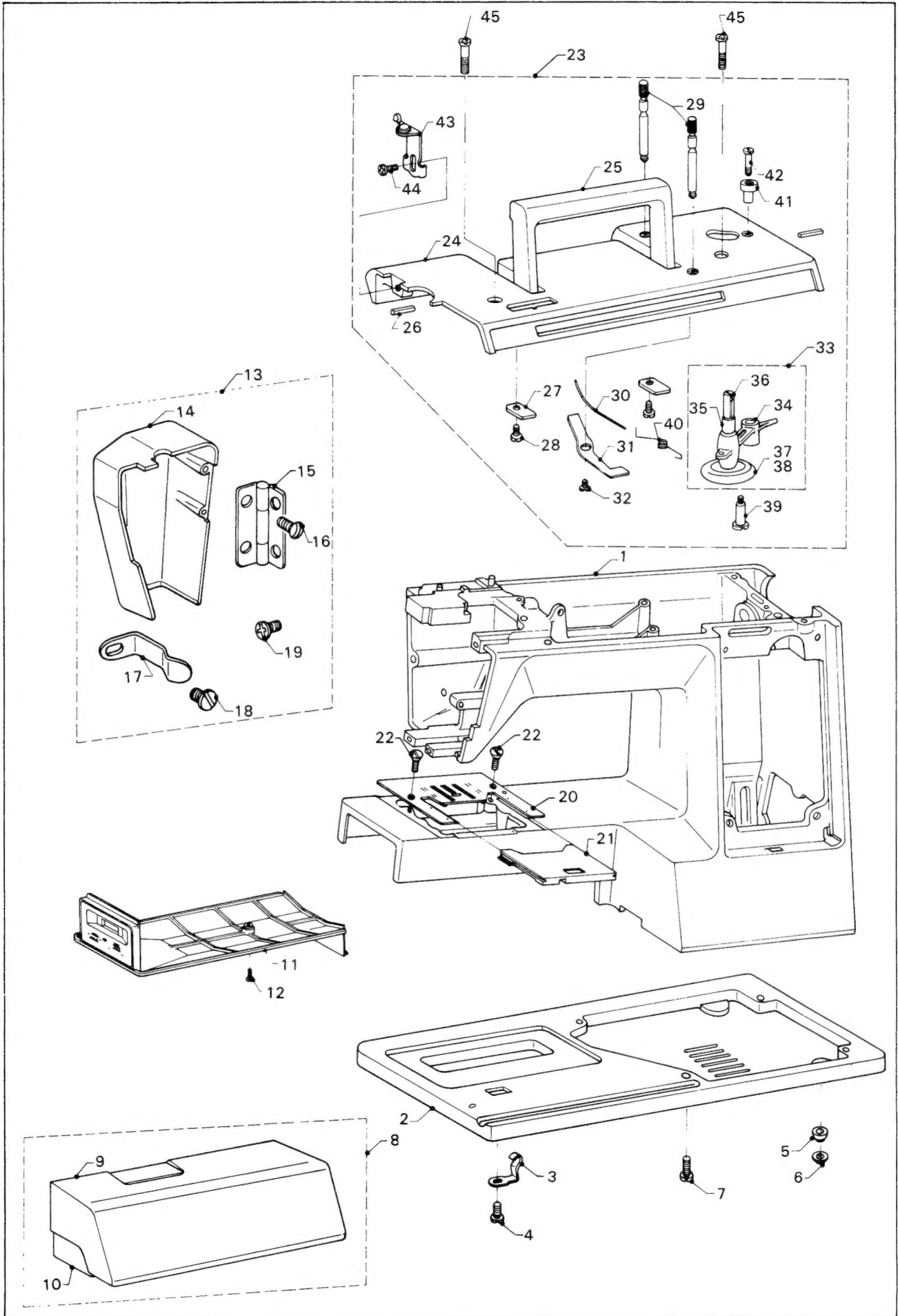

INDEX NO.	WSM NO.	REF. NO.	PARTS NAME	QTY	MODEL NO.		
					2220	2221	2222
1.			Arm	1	0	0	0
2.	6563	950001-171	Base	1	0	0	0
3.	6564	950001-168	Base Spring	1	0	0	0
4.	6565	10955	Screw For No. 3	1	0	0	0
5.	6566	950001-152	Rubber Foot	4	0	0	0
6.	6567	40303	Push Nut For No. 5	4	0	0	0
7.	6568	10947	Set Screw For No. 2	4	0	0	0
8.	6569	950001-160	Accessory Box Ass'y	1	0	0	0
9.		950001-164	Accessory Box Cover	1	0	0	0
10.		950001-165	Accessory Box	1	0	0	0
11.	6570	950001-162	Bed Cover	1	0	0	0
12.	6571	10942	Set Screw For No. 11	1	0	0	0
13.		950001-320	Face Cover Ass'y	1	0	0	0
14.	6572	950001-321	Face Cover	1	0	0	0
15.		150001-330	Face Cover Hinge	1	0	0	0
16.		10404	Set Screw For No. 15	2	0	0	0
17.	6574	150001-325	Face Cover Spring	1	0	0	0
18.	6577	10927-B	Set Screw For No. 17	1	0	0	0
19.		10914	Set Screw For No. 13	2	0	0	0
20.	6580	950001-510	Needle Plate	1	0	0	0
21.	6581	950001-521	Slide Plate	1	0	0	0
22.		10401	Set Screw For No. 20	2	0	0	0
23.		950001-310	Top Cover Ass'y	1	0	0	0
24.	6582	950001-311	Top Cover	1	0	0	0
25.	6583	950001-373	Handle	1	0	0	0
26.		50304	Pin	2	0	0	0
27.		950001-385	Lock Plate For No. 26	2	0	0	0
28.		10907-A	Set Screw For No. 27	2	0	0	0
29.		150002-181-A	Spool Pin	2	0	0	0
30.	6584	550002-191	Spool Pin Spring	1	0	0	0
31.		550002-192-B	Lock Plate For No. 30	1	0	0	0
32.		10907-A	Set Screw For No. 31	1	0	0	0
33.	6585	950002-601	Bobbin Winder Frame Ass'y	1	0	0	0
34.		950002-621	Bobbin Winder Frame	1	0	0	0
35.		950002-641	Bobbin Winder Spindle	1	0	0	0
36.		150002-643-A	Bobbin Stopper Spring	1	0	0	0
37.		150002-631-A	Rubber Ring Base	1	0	0	0
38.		710002-632	Rubber Ring	1	0	0	0
39.	6586	150002-263-A	Set Screw For No. 33	1	0	0	0
40.	6587	150002-644-C	Bobbin Winder Frame Spring	1	0	0	0
41.		150002-626	Bobbin Winder Stopper	1	0	0	0
42.		11101	Set Screw For No. 41	1	0	0	0
43.		150002-680-C	Thread Guide For Bobbin Winding	1	0	0	0
44.		10927	Set Screw For No. 43	1	0	0	0
45.	6588	10944	Set Screw For No. 23	2	0	0	0

2. Upper Thread, Presser Bar Parts

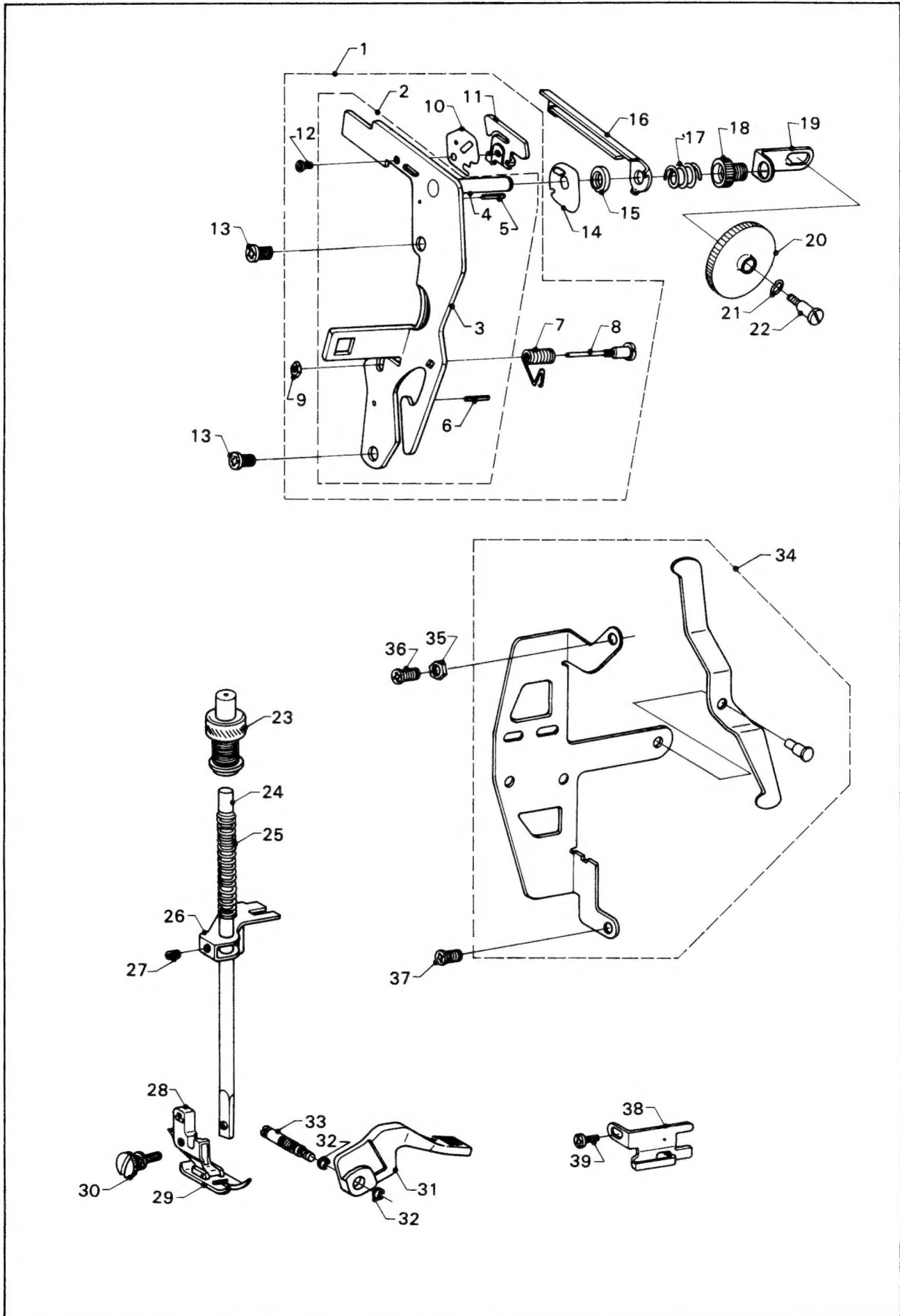

INDEX NO.	WSM NO.	REF. NO.	PARTS NAME	QTY	MODEL NO.		
					2220	2221	2222
1.	6589	950002-106	Thread Guide Plate Ass'y — L —	1	0	0	0
2.		95002-160	Thread Guide Plate Ass'y — S —	1	0	0	0
3.		95002-164	Thread Guide Plate	1	0	0	0
4.		550002-124	Thread Guide Plate Stud	1	0	0	0
5.		50402-A	Spring Pin	1	0	0	0
6.		50411-C	Spring Pin	1	0	0	0
7.	6590	550002-137	Check Spring	1	0	0	0
8.	6591	550002-135	Check Spring Stud	1	0	0	0
9.	6593	30107	Nut	1	0	0	0
10.	6594	950002-134	Pre-Tension Plate	1	0	0	0
11.	6595	950002-171	Thread Guide No. 1	1	0	0	0
12.	6596	10940	Set Screw For No. 11	1	0	0	0
13.	6597	10407	Set Screw For No. 2	2	0	0	0
14.		950002-133	Intermediate Disc	1	0	0	0
15.		550002-131	Tension Disc — R —	1	0	0	0
16.		950002-394	Tension Release Plate	1	0	0	0
17.		550002-138	Tension Spring	1	0	0	0
18.		550002-126	Tension Adjusting Screw	1	0	0	0
19.		550002-155	Connecting Plate	1	0	0	0
20.	6598	550002-151	Tension Dial	1	0	0	0
21.	6599	60403	Wave Washer	1	0	0	0
22.	6601	11009	Tension Dial Screw	1	0	0	0
23.		550002-307	Pressure Regulator	1	0	0	0
24.		550002-361	Presser Bar	1	0	0	0
25.		950002-362	Presser Bar Spring	1	0	0	0
26.		950002-376	Presser Bar Bracket	1	0	0	0
27.		10125	Set Screw For No. 26	1	0	0	0
28.		950002-423	Zigzag Sewing Foot Holder	1	0	0	0
29.		950002-352	Zigzag Sewing Foot	1	0	0	0
30.		710002-142	Set Screw For No. 28	1	0	0	0
31.	6602	950002-366	Presser Bar Lifter	1	0	0	0
32.	6603	40106-A	E-Ring	2	0	0	0
33.	6604	950002-367	Presser Bar Lifter Stud	1	0	0	0
34.		950008-170	Socket Holding Plate Ass'y	1	0	0	0
35.		30108	Nut	1	0	0	0
36.		10943	Screw	1	0	0	0
37.		10941	Set Screw For No. 34	1	0	0	0
38.	6605	950002-162	Thread Guide No. 2	1	0	0	0
39.	6606	10941	Set Screw For No. 38	1	0	0	0

3. Upper Shaft, Lower Shaft Parts

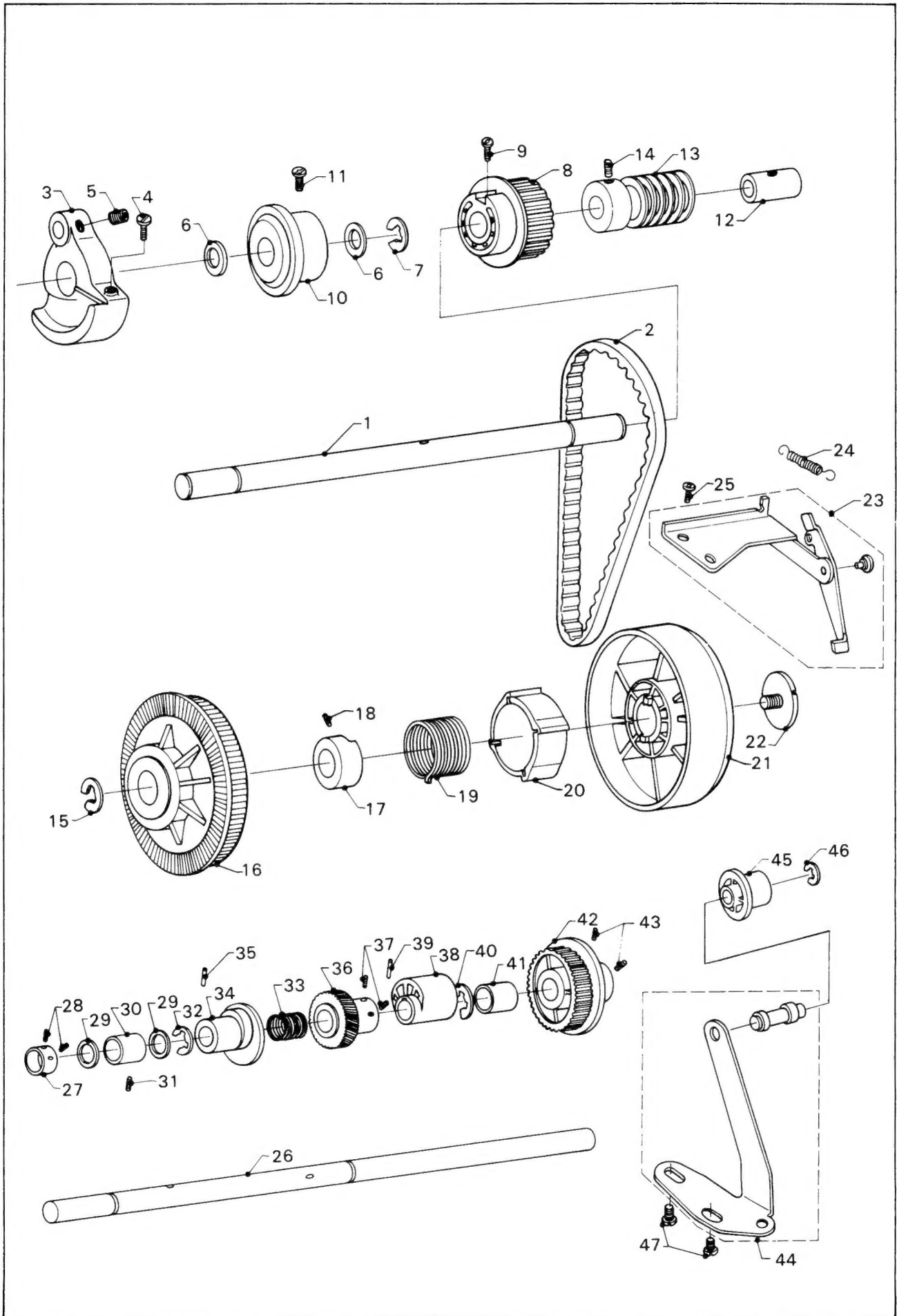

INDEX NO.	WSM NO.	REF. NO.	PARTS NAME	QTY	MODEL NO.		
					2220	2221	2222
1.	6607	950003-111	Upper Shaft	1	0	0	0
2.		950003-125	Timing Belt	1	0	0	0
3.		950003-131	Crank Weight	1	0	0	0
4.		10948	Set Screw For No. 3	1	0	0	0
5.		10126	Set Screw For Crank Rod	1	0	0	0
6.		60125	Plastic Washer	2	0	0	0
7.		40108	E-Ring	1	0	0	0
8.		950003-121	Upper Timing Gear	1	0	0	0
9.		10943	Set Screw For No. 8	1	0	0	0
10.		150003-112-E	Upper Shaft Bushing — F —	1	0	0	0
11.		10910	Set Screw For No. 10	1	0	0	0
12.		150003-114-C	Upper Shaft Bushing — R —	1	0	0	0
13.		950005-143	Worm Gear	1	0	0	0
14.		10125	Set Screw For No. 13	1	0	0	0
15.		40108	E-Ring	1	0	0	0
16.	6608	950003-154	Pulley	1	0	0	0
17.		950003-141	Clutch Bushing	1	0	0	0
18.		10126	Set Screw For No. 17	1	0	0	0
19.		950003-143	Clutch Spring	1	0	0	0
20.		950003-142	Clutch	1	0	0	0
21.	6609	950003-151	Hand Wheel	1	0	0	0
22.	6610	10936	Hand Wheel Screw	1	0	0	0
23.		950003-180	Clutch Lever Bracket Ass'y	1	0	0	0
24.		950003-183	Clutch Lever Spring	1	0	0	0
25.		10941	Set Screw For No. 24	1	0	0	0
26.		950003-541	Lower Shaft	1	0	0	0
27.		950003-551	Lower Shaft Collar	1	0	0	0
28.		10125	Set Screw For No. 27	1	0	0	0
29.		60124	Plastic Washer	2	0	0	0
30.		950003-543	Lower Shaft Bushing — F —	1	0	0	0
31.		10126	Set Screw For No. 30	1	0	0	0
32.		40101-A	E-Ring	1	0	0	0
33.		950004-716	Feed Lifting Cam Spring	1	0	0	0
34.		950004-715	Feed Lifting Cam	1	0	0	0
35.		50303	Set Pin For 34	1	0	0	0
36.	6611	950003-507	Lower Shaft Gear	1	0	0	0
37.		10126	Set Screw For No. 36	2	0	0	0
38.		950004-151	Feed Cam	1	0	0	0
39.		50303	Set Pin For 38	1	0	0	0
40.		40101-A	E-Ring	1	0	0	0
41.	6612 6613	950003-542	Lower Shaft Bushing — R —	1	0	0	0
42.		950003-581	Lower Timing Gear	1	0	0	0
43.		10126	Set Screw For No. 42	2	0	0	0
44.		950003-190	Idler Pulley Bracket	1	0	0	0
45.		950003-192	Idler Pulley	1	0	0	0
46.		40104-A	E-Ring	1	0	0	0
47.		10946	Set Screw For No. 44	2	0	0	0

4. Needle Bar Parts

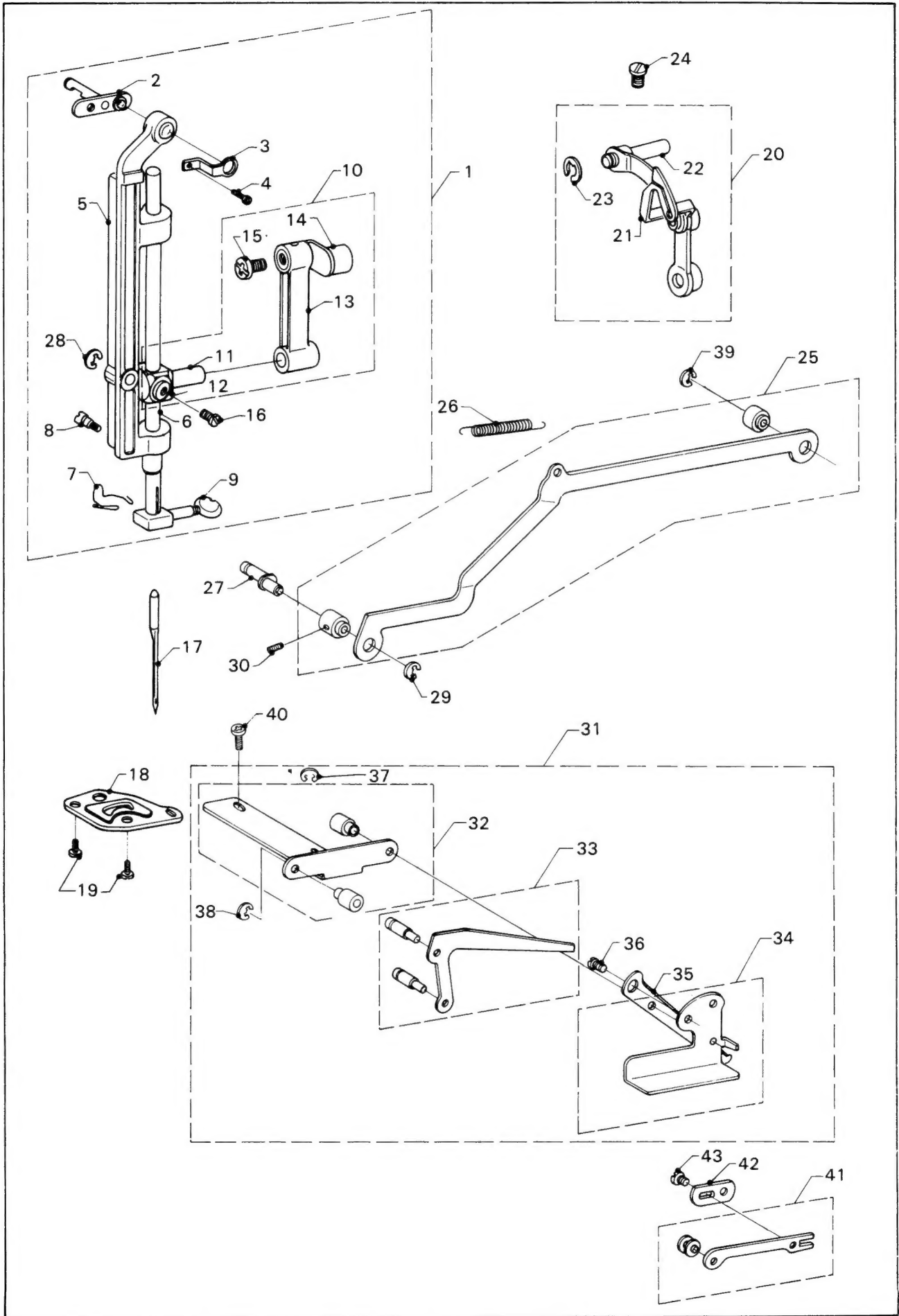

INDEX NO.	WSM NO.	REF. NO.	PARTS NAME	QTY	MODEL NO.		
					2220	2221	2222
1.		950002-330	Needle Bar Support Ass'y — L —	1	0	0	0
2.		950002-304	Needle Bar Support Plate Ass'y	1	0	0	0
3.		950002-326	Need Bar Support Spring	1	0	0	0
4.		10941	Set Screw For No. 3	1	0	0	0
5.		950002-305	Needle Bar Support Ass'y	1	0	0	0
6.		350002-311-D	Needle Bar	1	0	0	0
7.	6614	350002-341-D	Needle Bar Thread Guide	1	0	0	0
8.	6616	11003	Set Screw For No. 7	1	0	0	0
9.	6617	350002-343-A	Needle Clamp Ass'y	1	0	0	0
10.		150002-320	Needle Bar Crank Ass'y	1	0	0	0
11.		150002-327-A	Needle Bar Connecting Rod	1	0	0	0
12.		150002-328-C	Needle Bar Connector	1	0	0	0
13.	6618	150002-321-B	Needle Bar Crank Rod	1	0	0	0
14.		950002-422	Needle Bar Crank	1	0	0	0
15.		150002-217-A	Set Screw For No. 13	1	0	0	0
16.		20105	Set Screw For No. 6	1	0	0	0
17.		150002-482	Needle #14	1	0	0	0
18.		950002-329	Guide Plate For Needle Bar Support	1	0	0	0
19.		20106	Set Screw For No. 18	2	0	0	0
20.	6619	150002-401-A	Take-Up Lever Ass'y	1	0	0	0
21.		150002-410-D	Take-Up Lever	1	0	0	0
22.		150002-414	Lever Support Shaft	1	0	0	0
23.		40103-A	E-Ring	1	0	0	0
24.		10943	Set Screw For No. 22	1	0	0	0
25.	6620	950005-510	Connecting Rod Ass'y	1	0	0	0
26.		950005-513	Connecting Rod Spring	1	0	0	0
27.		950005-512	Eccentric Pin	1	0	0	0
28.		40107-A	Arched E-Ring	1	0	0	0
29.		40104-A	E-Ring	1	0	0	0
30.		10125	Set Screw For No. 25	1	0	0	0
31.		950005-102	Zigzag Regulator Ass'y	1	0	0	0
32.		950005-103	Zigzag Regulator Bracket Ass'y	1	0	0	0
33.		950005-520	Zigzag Regulating Arm Ass'y	1	0	0	0
34.		950005-110	Zigzag Regulator	1	0	0	0
35.		950005-111	Zigzag Drive Arm	1	0	0	0
36.		10941	Set Screw For 35	1	0	0	0
37.		40104-A	E-Ring	1	0	0	0
38.		40104-A	E-Ring	1	0	0	0
39.		40104-A	E-Ring	1	0	0	0
40.		10941	Set Screw For No. 31	2	0	0	0
41.		950005-180	Zigzag Adjusting Rod Ass'y — A —	1	0	0	0
42.		950005-182	Zigzag Adjusting Rod — B —	1	0	0	0
43.		10940	Set Screw For 42	1	0	0	0

5. Hook Assembly Parts

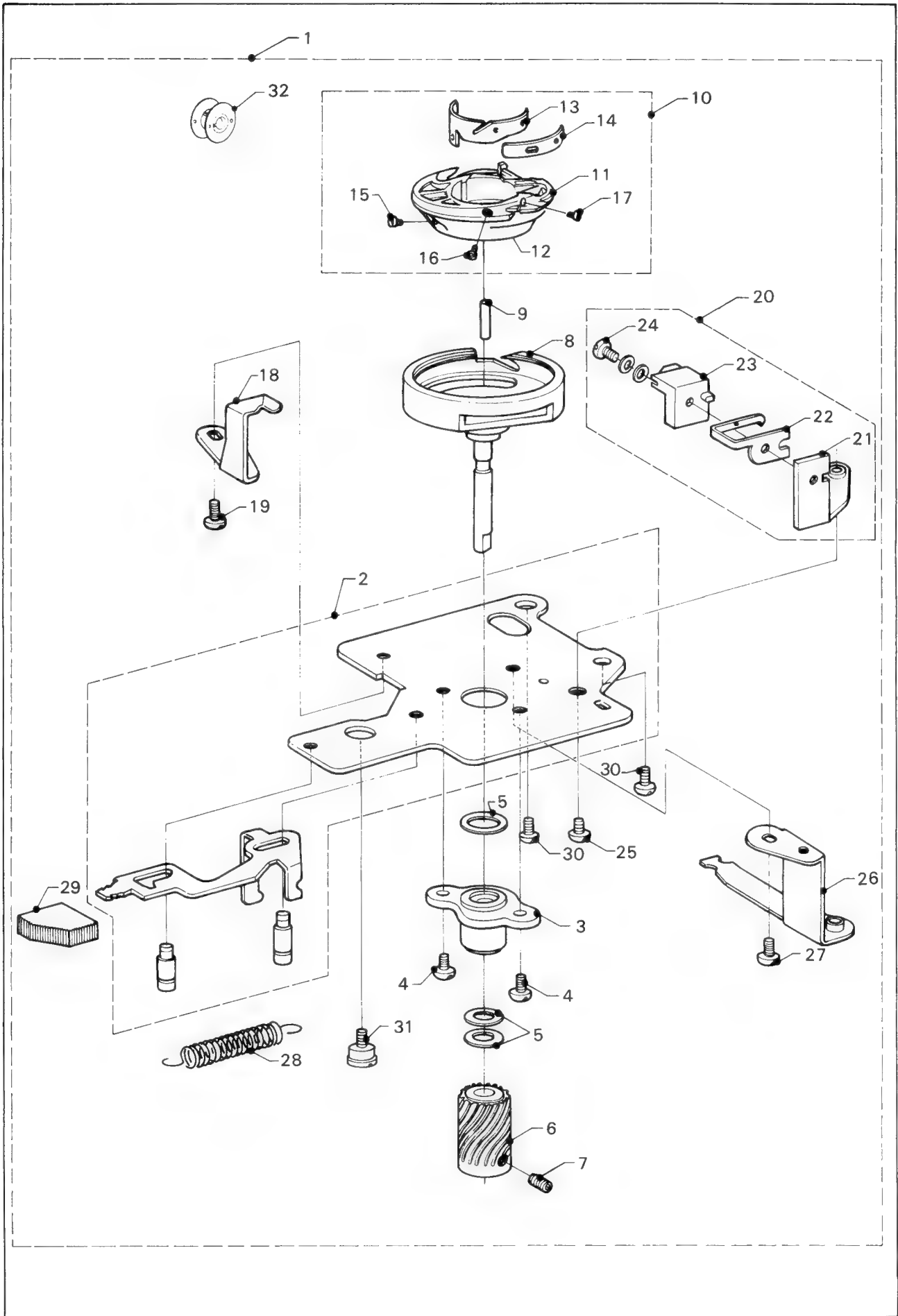

INDEX NO.	WSM NO.	REF. NO.	PARTS NAME	QTY	MODEL NO.		
					2220	2221	2222
1.		950003-503	Hook Support Ass'y — L —	1	0	0	0
2.		950003-530	Hook Supporting Plate Ass'y	1	0	0	0
3.		950003-536	Hook Shaft Bushing	1	0	0	0
4.		10941	Set Screw For No. 3	2	0	0	0
5.		60123	Plastic Washer	2	0	0	0
6.	6621	950003-545	Hook Shaft Gear	1	0	0	0
7.		10125	Set Screw For No. 6	1	0	0	0
8.	6622	950003-531	Hook	1	0	0	0
9.		950003-538	Felt	1	0	0	0
10.	6623	950003-560	Bobbin Case Ass'y	1	0	0	0
11.		950003-561	Bobbin Case	1	0	0	0
12.		950003-562	Bobbin Case Bottom Cover	1	0	0	0
13.		950003-563	Lower Tension Plate	1	0	0	0
14.		950003-564	Lower Tension spring	1	0	0	0
15.		10934	Set Screw For No. 13	1	0	0	0
16.		10956	Lower Tension Adjusting Screw	1	0	0	0
17.		10935	Set Screw For No. 14	1	0	0	0
18.		950003-567	Stopper For Reverse Revolution	1	0	0	0
19.		10941	Set Screw For No. 18	1	0	0	0
20.	6624	950003-590	Hook Retainer Ass'y	1	0	0	0
21.		950003-591	Hook Retainer	1	0	0	0
22.		950003-592	Retainer Spring	1	0	0	0
23.		950003-593	Retainer Spring Guide	1	0	0	0
24.		10938	Set Screw For No. 22 and No. 23	1	0	0	0
25.		10941	Set Screw For No. 20	1	0	0	0
26.		950004-544	Arm For Feed Bar Spring	1	0	0	0
27.		10941	Set Screw For No. 26	1	0	0	0
28.		950004-764	Drop Lever Spring	1	0	0	0
29.	6625	950004-761	Drop Lever Knob	1	0	0	0
30.		10941	Set Screw For No. 2	2	0	0	0
31.		950003-537	Set Screw For No. 2	1	0	0	0
32.		950003-520	Bobbin	1	0	0	0

6. Feed Regulating Parts

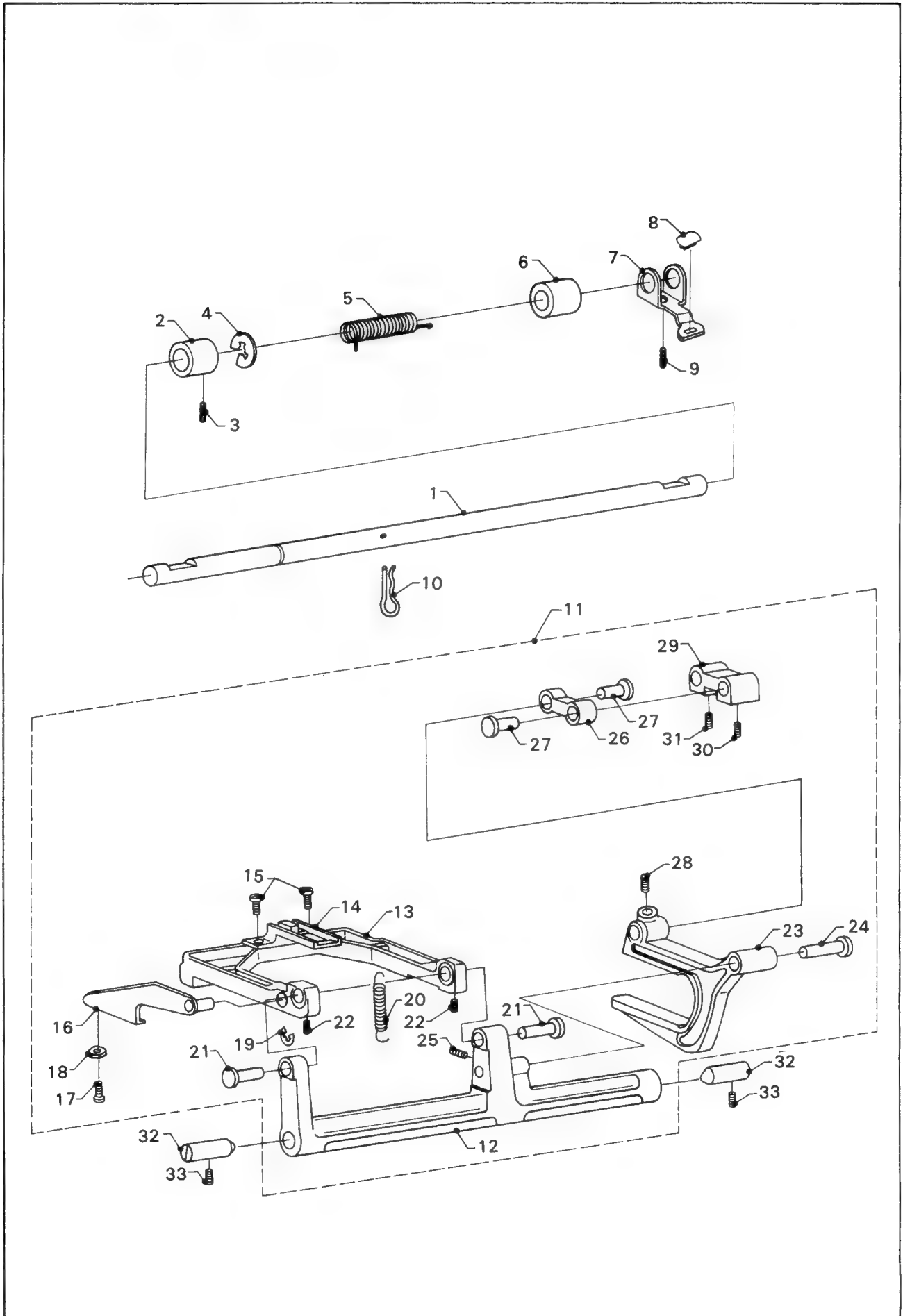

7. Feed Regulating Parts

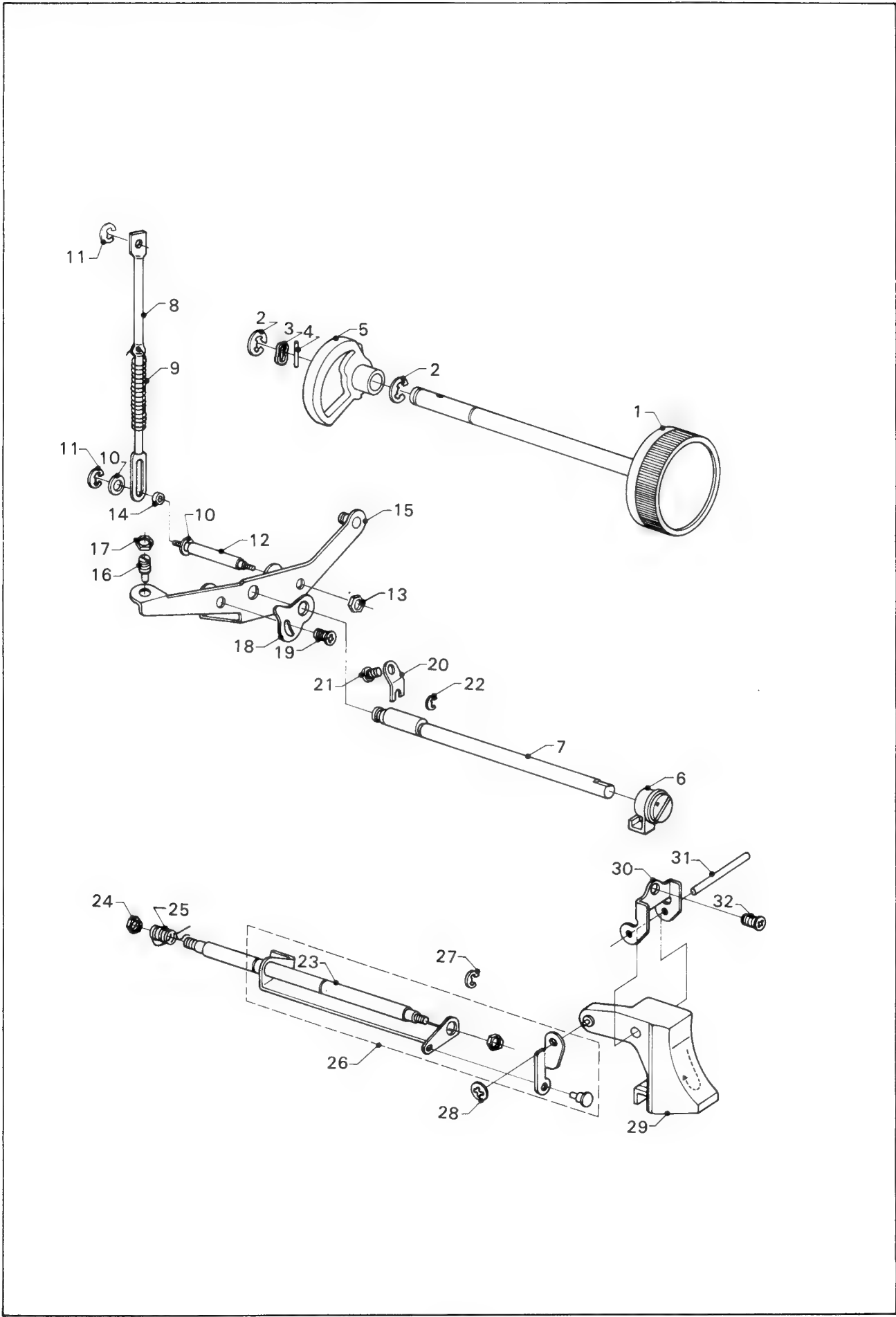

INDEX NO.	WSM NO.	REF. NO.	PARTS NAME	QTY	MODEL NO.		
					2220	2221	2222
1.	6628	950004-316	Stitch Length Dial	1	0	0	0
2.		40106-A	E-Ring	2	0	0	0
3.		60406	Wave Washer	1	0	0	0
4.		50404-A	Spring Pin	1	0	0	0
5.		950004-112	Feed Control Cam	1	0	0	0
6.	6629	950004-117	Feed Slight Adjuster	1	0	0	0
7.		950004-118	Feed Slight Adjuster Shaft	1	0	0	0
8.	6630	950006-631	Feed Connecting Rod	1	0	0	0
9.	6631	150006-632	Feed Connecting Rod Spring	1	0	0	0
10.		60122-A	Flat Washer	2	0	0	0
11.		40109	E-Ring	2	0	0	0
12.		950006-625	Stretch Stitch Adjusting Screw	1	0	0	0
13.		30108	Nut For No. 12	1	0	0	0
14.		150006-158	Plastic Collar	1	0	0	0
15.		950004-130	Feed Adjusting Arm	1	0	0	0
16.		10939	B • H Adjusting Screw	1	0	0	0
17.		30403	Adjustable Nut	1	0	0	0
18.		950004-379	Reverse Adjusting Plate	1	0	0	0
19.		10941	Set Screw For No. 18	1	0	0	0
20.		950004-128	Spring Plate For No. 7	1	0	0	0
21.		10941	Set Screw For No. 20	1	0	0	0
22.		40106-A	E-Ring	1	0	0	0
23.		950006-159	Reverse Arm Shaft	1	0	0	0
24.		30108	Nut	2	0	0	0
25.		950004-364	Reverse Button Spring	1	0	0	0
26.		950004-367	Reverse Link Ass'y	1	0	0	0
27.		40106-A	E-Ring	1	0	0	0
28.		40302	Circular-Ring	1	0	0	0
29.	6632	950004-361	Reverse Button	1	0	0	0
30.		950004-351	Reverse Button Support	1	0	0	0
31.		50305	Reverse Button Pin	1	0	0	0
32.		10941	Set Screw For No. 30	1	0	0	0

8. Zigzag Generating Parts

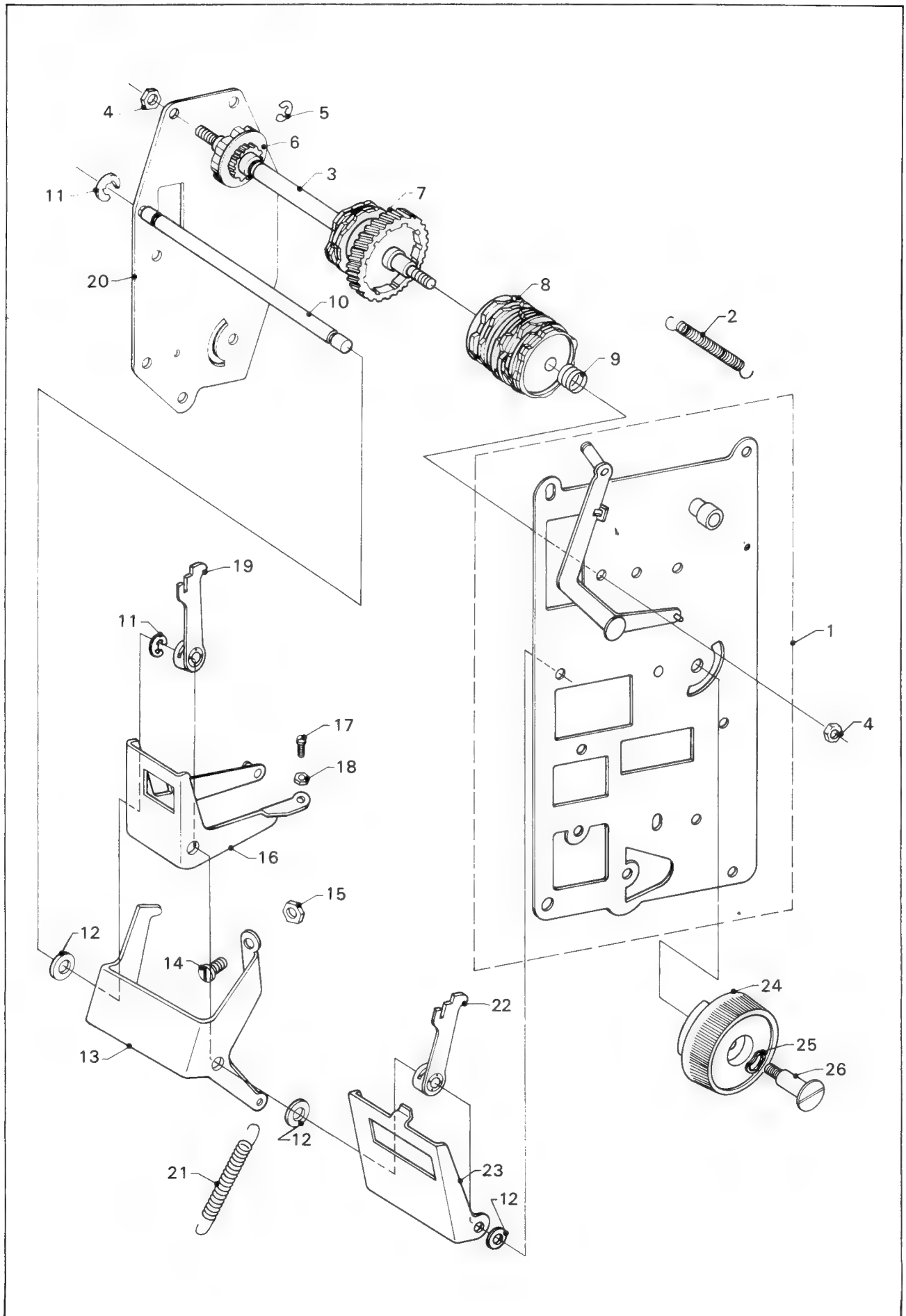

INDEX NO.	WSM NO.	REF. NO.	PARTS NAME	QTY	MODEL NO.		
					2220	2221	2222
1.		970006-101	Pattern Cam Mounting Base — F —	1			0
		950006-101	Pattern Cam Mounting Base — F —	1		0	
		960006-101	Pattern Cam Mounting Base — F —	1	0		
2.		950005-545	Width Control Arm Spring	1	0	0	0
3.		950006-136	Pattern Cam Shaft	1	0	0	0
4.		30108	Nut	2	0	0	0
5.		40101-B	E-Ring	1	0	0	0
6.		950006-536	Secession Cam	1	0	0	0
7.		950006-310	Pattern Cam — B —	1	0	0	0
8.		950006-110	Pattern Cam — A —	1		0	0
		960006-110	Pattern Cam — A —	1	0		
9.		950006-536	Pattern Cam Fix Spring	1	0	0	0
10.		950006-117	Connecting Finger Shaft	1	0	0	0
11.		40106-A	E-Ring	2	0	0	0
12.		60112	Washer	3	0	0	0
13.		950006-525	Secession Arm	1	0	0	0
14.		950006-538	Secession Adjusting Screw	1	0	0	0
15.		30403	Adjustable Nut	1	0	0	0
16.		950006-670	Feed Finger Guide Plate	1		0	0
		960006-670	B • H Feed Arm	1	0		
17.		10939	Adjustable Screw	1	0	0	0
18.		30403	Adjustable Nut	1	0	0	0
19.		950006-230	Feed Contacting Finger	1		0	0
20.		950006-103	Pattern Cam Mounting Base — R —	1	0	0	0
21.		950006-537	Secession Arm Spring	1	0	0	0
22.		950006-230	Zigzag Width Contacting Finger	1	0	0	0
23.		950006-143	Width Finger Guide Plate	1	0	0	0
24.	6633	950007-523	Zigzag Width Control Dial	1	0	0	0
25.	6634	60406	Wave Washer	1	0	0	0
26.	6635	950007-525	Dial Shaft	1	0	0	0

9. Pattern Selecting Parts

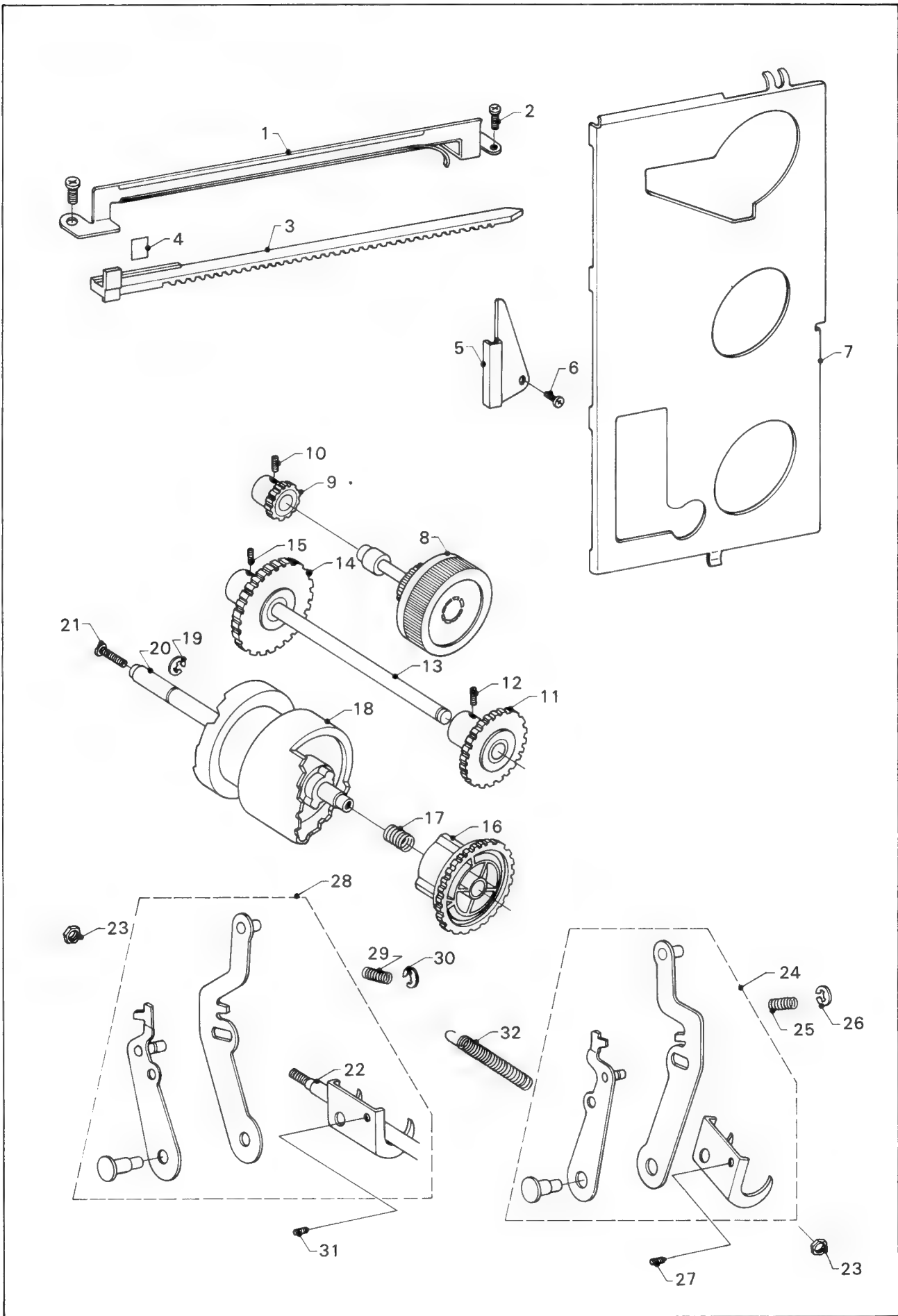

INDEX NO.	WSM NO.	REF. NO.	PARTS NAME	QTY	MODEL NO.		
					2220	2221	2222
1.		950007-651	Indicator Guide	1	0	0	0
2.		10941	Set Screw For No. 1	2	0	0	0
3.		950007-653	Indicator Rack	1	0	0	0
4.		950007-652	Indicator	1	0	0	0
5.		950007-654	Indicator Rack Guide	1	0	0	0
6.	6636	10941	Set Screw For No. 5	1	0	0	0
7.		950007-131	Panel Bracket	1	0	0	0
8.		950007-521	Pattern Selecting Dial	1	0	0	0
9.		950007-641	Selecting Gear — A —	1	0	0	0
10.		10124	Set Screw For No. 9	1	0	0	0
11.		950007-642	Selecting Gear — B —	1	0	0	0
12.		10124	Set Screw For No. 11	1	0	0	0
13.		950007-632	Selecting Gear Shaft	1	0	0	0
14.		950007-643	Selecting Gear — C —	1	0	0	0
15.		10124	Set Screw For No. 14	1	0	0	0
16.		950006-391	Selecting Cam Gear	1	0	0	0
17.		950006-119	Selecting Cam Spring	1	0	0	0
18.		970006-531	Selecting Cam	1			0
		950006-531	Selecting Cam	1		0	
		960006-531	Selecting Cam	1	0		
19.		40101-B	E-Ring	1	0	0	0
20.		950006-535	Selecting Cam Shaft	1	0	0	0
21.		10945	Set Screw For No. 20	1	0	0	0
22.		950006-159	Selecting Arm Shaft	1	0	0	0
23.		30108	Nut	2	0	0	0
24.		950006-105	Width Cam Selecting Arm Ass'y	1	0	0	0
25.		950006-157	Spring	1	0	0	0
26.		40109	E-Ring	1	0	0	0
27.		10127	Set Screw For No. 24	1	0	0	0
28.		950006-106	Feed Cam Selecting Arm Ass'y	1		0	0
29.		950006-157	Spring	1		0	0
30.		40109	E-Ring	1		0	0
31.		10127	Set Screw For No. 28	1		0	0
32.		950006-156	Selecting Arm Spring	1		0	0
		960006-156	Selecting Arm Spring	1	0		

10. Specific Parts-①

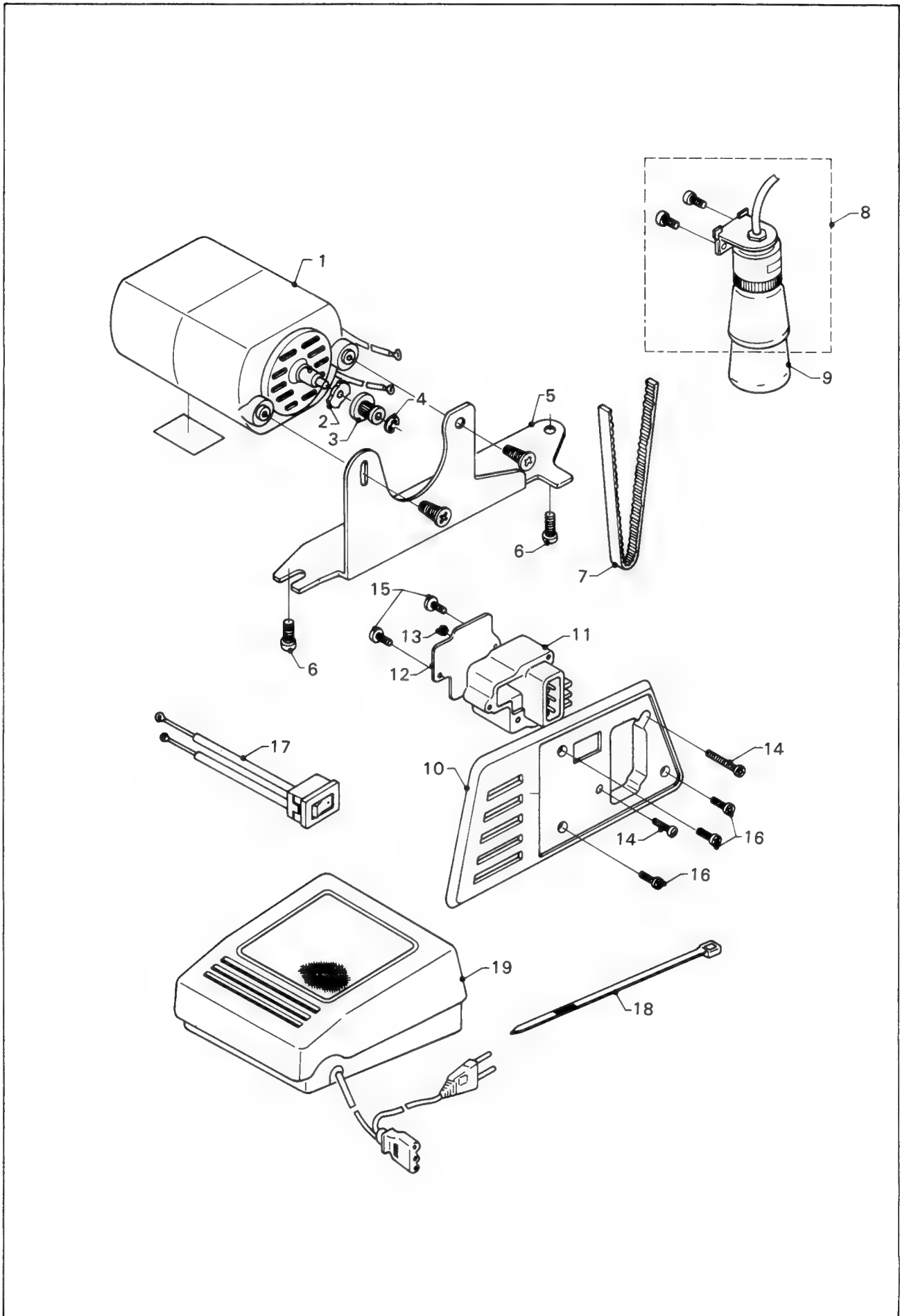

INDEX NO.	PART NO.	REF. NO.	PARTS NAME	QTY	MODEL NO.		
					2220	2221	2222
1.	6642			1	0	0	0
			Motor Ass'y —	1	0	0	0
			Cushion rubber	1	0	0	0
			Motor Pulley	1	0	0	0
			E-Ring	1	0	0	0
			Motor Bracket	1	0	0	0
6.		10946-A	Set Screw For No. 5	2	0	0	0
7.	6637	550008-843-B	Timing Belt	1	0	0	0
8.	74315	550028-110-A	Lampholder Ass'y	1	0	0	0
9.	4420	550008-116	Bulb	1	0	0	0
10.	6638	950008-839	Receptacle Bracket	1	0	0	0
11.	6639	950008-838	Receptacle	1	0	0	0
12.		950008-846-A	Receptacle Cover	1	0	0	0
13.		30405	Nut	1	0	0	0
14.		10950	Set Screw For No. 11	2	0	0	0
15.		10949-A	Set Screw For No. 12	2	0	0	0
16.		10941-A	Set Screw For No. 10	3	0	0	0
17.	6640	950008-870	Switch	1	0	0	0
18.		950008-848	Cord Binder	3	0	0	0
19.	6641		Controller Ass'y	1	0	0	0
				1	0	0	0
				1	0	0	0

11. Specific Parts - ②

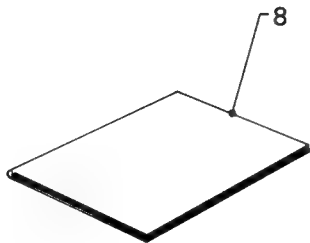
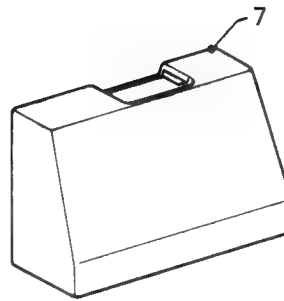
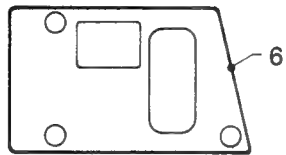
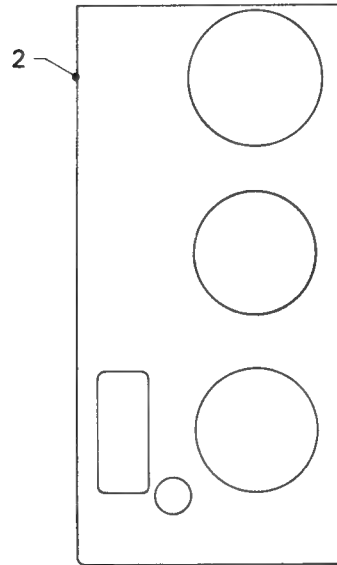

INDEX NO.	WSM NO.	REF. NO.	PARTS NAME	QTY	MODEL NO.		
					2220	2221	2222
1.	6643	970007-171	Pattern Indicating Panel	1			0
	6644	950007-171	Pattern Indicating Panel	1		0	
	6645	960007-171	Pattern Indicating Panel	1	0		
2.	6646	950007-113	Arm Panel	1		0	0
	6647	960007-113	Arm Panel	1	0		
3.		950007-172-A	Dial Panel	1	0	0	0
4.		950007-172-A	Dial panel	1	0	0	0
5.		950007-172-A	Dial Panel	1	0	0	0
6.		*	Nomenclature Plate	1	0	0	0
			* Specifications vary from Country to Country				
7.	6648	950019-110	Portable Case	1		0	0
		960019-112	Dust Cover	1	0		
8.	6649	950009-111	Instruction Book —English—	1		0	
				1		0	
				1		0	
				1		0	
		970009-111	Instruction Book —English—	1			0
				1			0
				1			0
				1			0
		960019-111	Instruction Book —English—	1	0		
				1	0		
				1	0		
				1	0		
				1	0		

12. Accessories

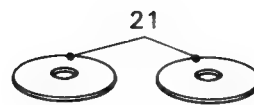
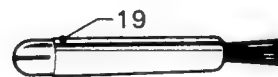
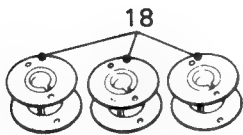
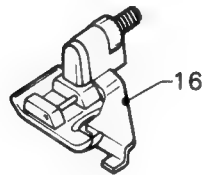
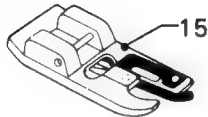
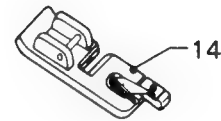
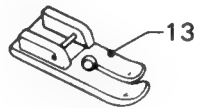
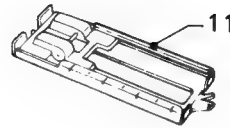
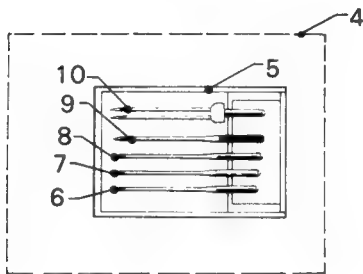

INDEX NO.	WSM NO.	REF. NO.	PARTS NAME	QTY	MODEL NO.		
					2220	2221	2222
1.	1627	719001-363	Screw Driver — L —	1	0	0	0
2.	1628	719001-364	Screw Driver — S —	1	0	0	0
3.	82530	719001-368	Oiler	1	0	0	0
4.	15054	950002-480	Needle Set	1	0	0	0
5.		950002-485	Needle Case	1	0	0	0
6.		150002-473	Needle #11	1	0	0	0
7.		150002-482	Needle #14	1	0	0	0
8.		150002-492	Needle #16	1	0	0	0
9.		150002-472	Ball Point Needle	1	0	0	0
10.		150002-491	Twin-Needle	1	0	0	0
11.	3593	950002-353	Buttonhole Foot	1	0	0	0
12.	3589	950002-360	Zipper Foot	1	0	0	0
13.	4912	950002-371	Straight Stitch Foot	1	0	0	0
14.	3588	950002-350	Hemmer Foot	1		0	0
15.	3587	950002-357	Overcasting Foot	1		0	0
16.	6219	950002-369	Blind Stitch Foot	1		0	0
17.	6526	950002-355	Quilting Guide	1	0	0	0
18.	6480	950003-520	Bobbin	3	0	0	0
19.	6065	950002-359	Cleaning Brush With Bobbin Extractor	1	0	0	0
20.	426130	719001-367	Buttonhole Cutter	1	0	0	0
21.	75734	719002-183	Felt	2	0	0	0

13 SERVICE MANUAL

Needle position in straight sewing

TOOL



95015(2.0mm)

DIAGNOSIS

[No. 2]

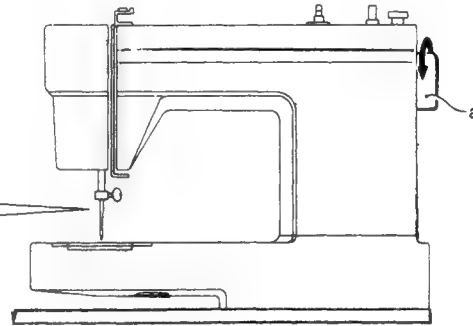
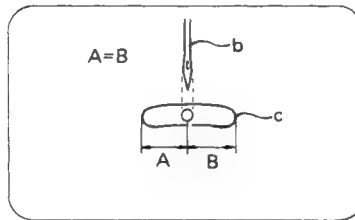

When hand wheel (a) is turned, needle (b) must remain at the center of needle hole of needle plate (c).

ADJUSTMENT

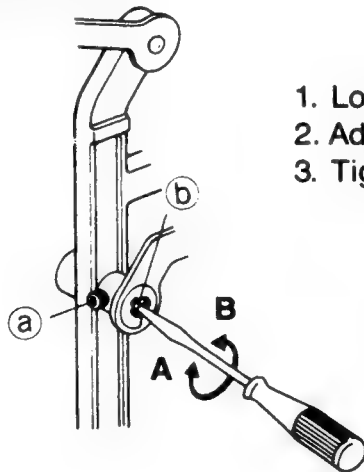

1. Loosen screw (a)
2. Adjust eccentric pin (b) in A or B direction.
3. Tighten screw (a) .

Height and twist of needle bar

TOOL-



Screwdriver



95015 (2mm)



Screwdriver



95034

PREPARATION

[No. 1]



Remove bobbin case

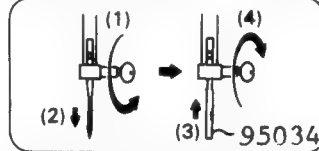
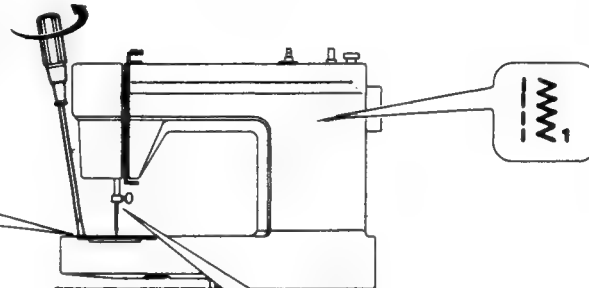

Remove needle Install 95034

DIAGNOSIS

[No. 2]

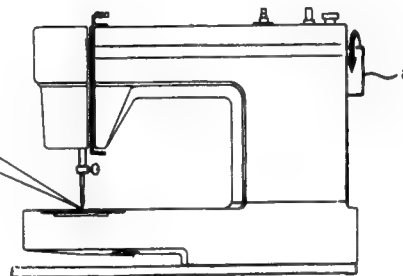
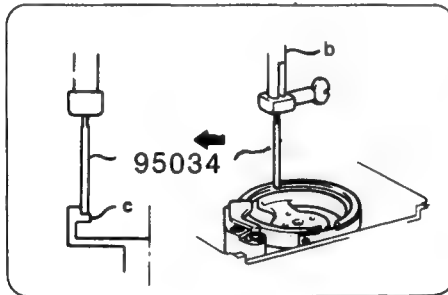

When hand wheel (a) is turned until needle bar (b) comes to its lowest position, 95034 must slightly touch top of rotary hook race face (c).

ADJUSTMENT

[No. 3]

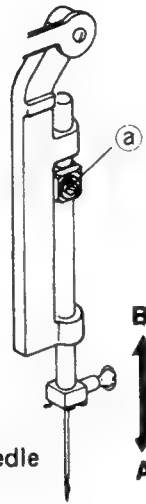

Loosen set screw of needle bar bracket (d).

[No. 4]

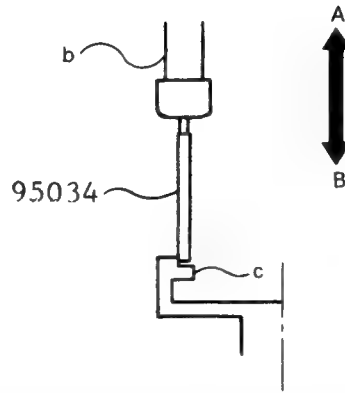

Move needle bar (b) in direction of A or B to adjust needle bar height. Then tighten set screw slightly.

[No. 5]

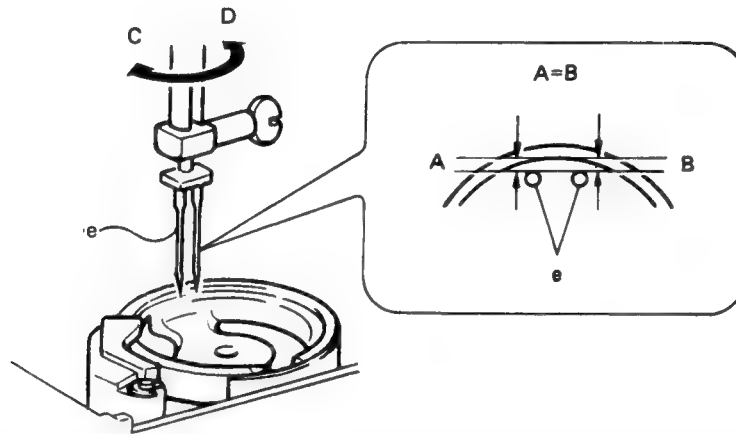

Install twin needle instead of 95034 and turn needle bar (b) in direction of C or D to adjust twist of needle bar. Then tighten set screw.

NOTE

1. Turn hand wheel slowly to avoid scratching rotary hook race face.

NOTE: _____

Needle position in zigzag sewing

TOOL



+ Philips screwdriver

PREPARATION

[No. 1]

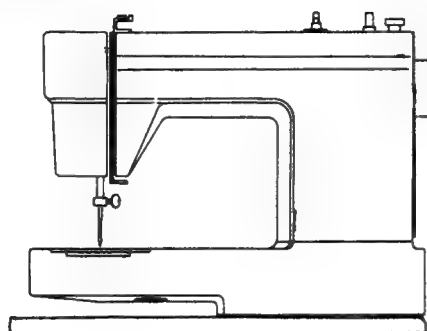

DIAGNOSIS

[No. 2]

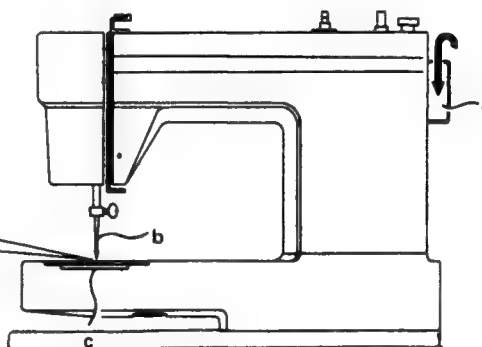
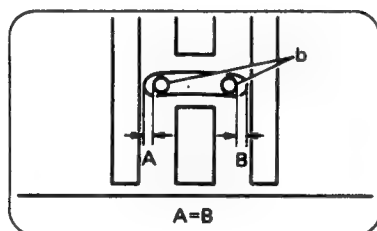

When hand wheel (a) is turned, left and right hand penetration of the needle must be equidistant from edge of needle hole of needle plate (c).

ADJUSTMENT

[No. 3]

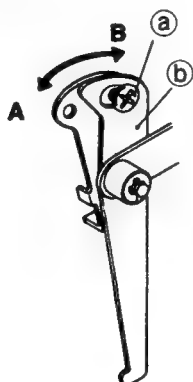

1. Loosen screw (a) .
2. Move zigzag width arm (b) . in A or B direction.
3. Tighten screw (a) .

Clearance between needle and point of hook

TOOL

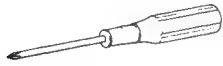

+ Philips screwdriver



- Screwdriver



95008



- Screwdriver

PREPARATION

[No. 1]

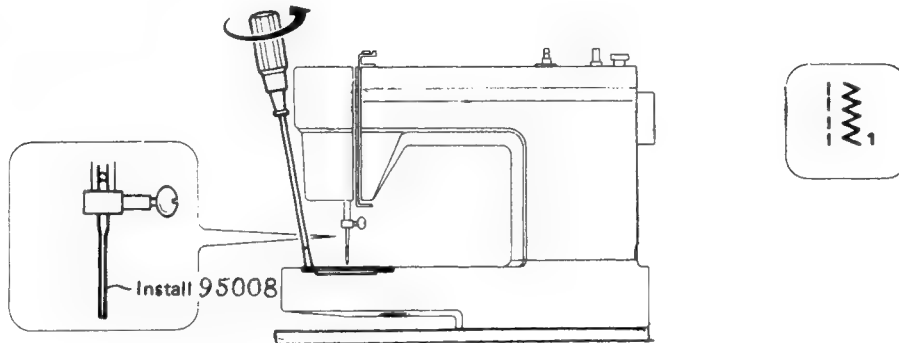

DIAGNOSIS

[No. 2]

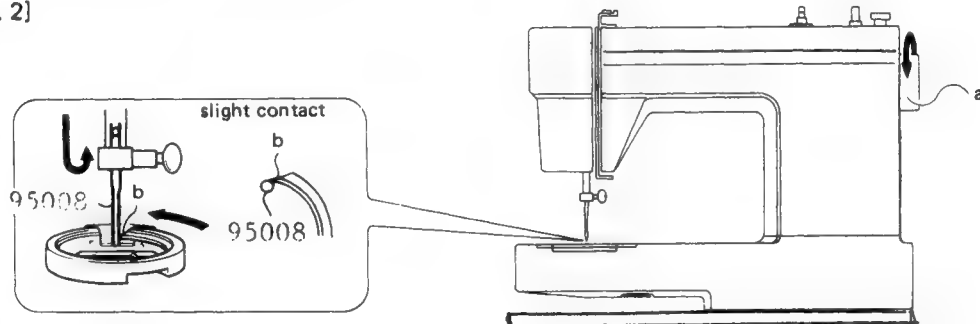

When hand wheel (a) is turned until 95008 meets with point of hook (b), 95008 should slightly touch point of hook.

ADJUSTMENT

[No. 3]

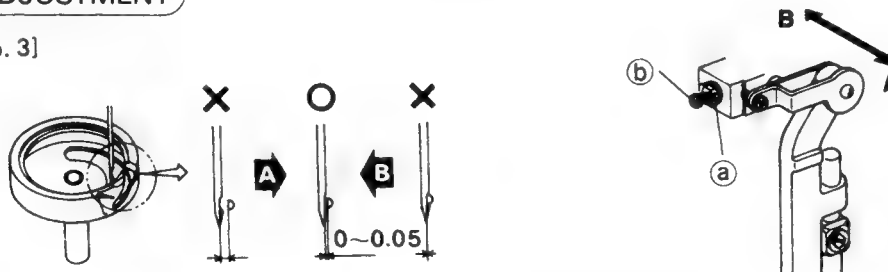

1. Loosen nut (a).
2. Loosen screw (b) (Do not take it out).
3. Move needle bar arm ass'y to adjust clearance between needle and point of hook.
4. Tighten screw (b).
5. Tighten nut (a).

NOTE: Be careful not to damage the hook with the needle.

NOTES: _____

Timing of needle and hook

TOOL



– Screwdriver



+ Philips screwdriver



95014 (2.5mm)

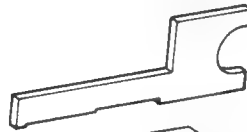

95005



95006



95007

PREPARATION

[No. 1]

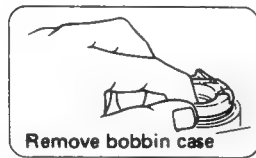

Remove bobbin case

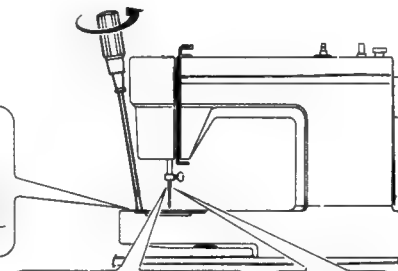

Remove presser foot

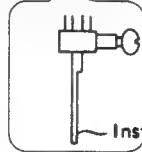

Install 95007



DIAGNOSIS

[No. 2]

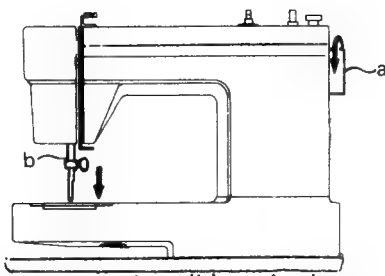

Move needle bar (b) to its lowest position.

[No. 3]

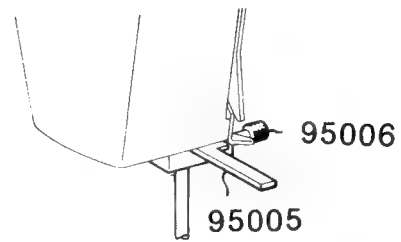

Hold 95005 with 95006

[No. 4]

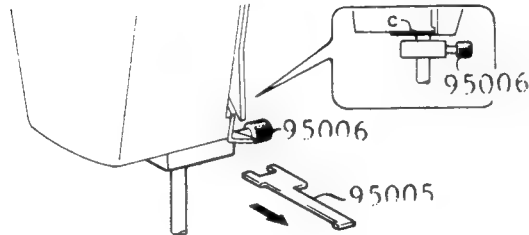

Pull out 95005

[No. 5]

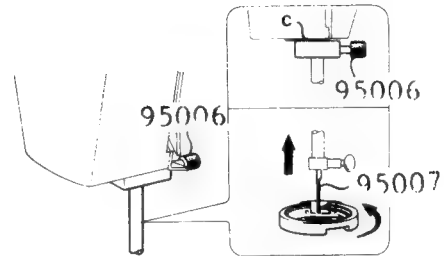

Turn hand wheel until 95006 contacts needle bar arm mounting base (c), and point of hook (d) must slightly touch 95007

ADJUSTMENT

[No. 6]

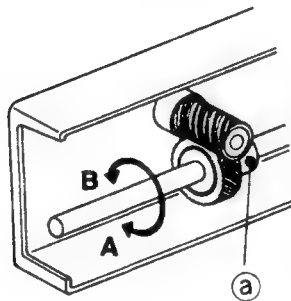

1. Loosen set screw a of lower gear.
2. Turn lower gear in A or B direction to match the center of the needle and the point of the hook.
3. Tighten screw a of lower Gear.

Needle swing

TOOL



+ Philips screwdriver



95015 (2.0 mm)

PREPARATION

[No. 1]

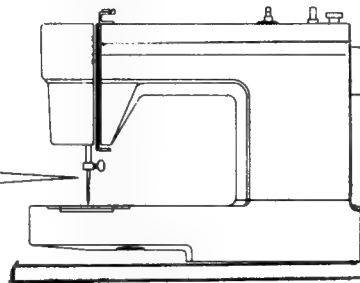
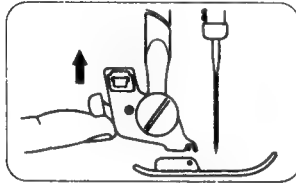

DIAGNOSIS

[No. 2]

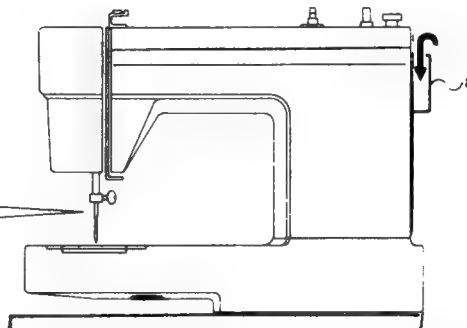
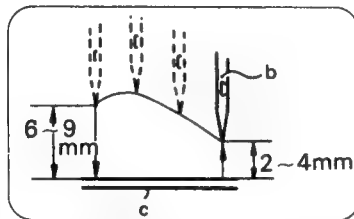

With upwards movement of needle (b) from its right hand lowest position by turning hand wheel (a), the needle should start to swing at 2 ~ 4mm above the upper surface of needle plate.

ADJUSTMENT

[No. 3]

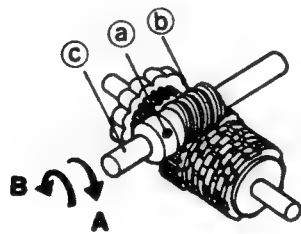

1. Loosen screw (a).
2. Hold worm gear (b).
3. Turn balance wheel in the required direction referring to the diagram.
4. Check backlash after adjusting.
5. Tighten screw (a).

Uneven density of side stitch in buttonholing

TOOL



+ Philips screwdriver



- Screwdriver

DIAGNOSIS

[No. 1]

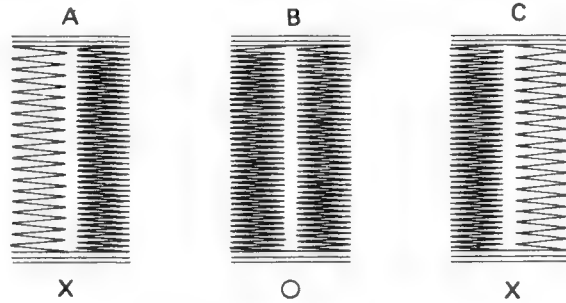

Stitch density of right and left side stitches should be approximately same, as in B.

ADJUSTMENT

[No. 2]

[No. 3]

BAR TACKING FOR BUTTONHOLING

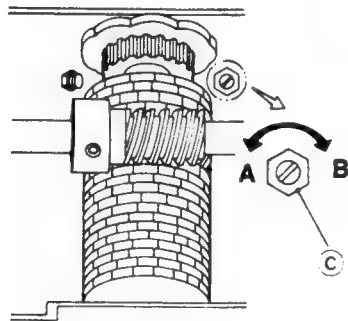

Turn adjustable screw in A or B direction.
* Do not attempt to turn locking nut ©

EQUALISING OF THE BUTTONHOLE

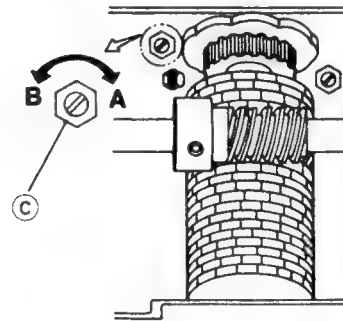

Turn adjusting screw in A or B direction.
* Do not attempt to turn locking nut ©

Stretch stitch feeding

TOOL

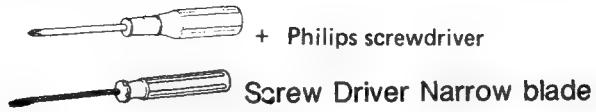

DIAGNOSIS

[No. 1]

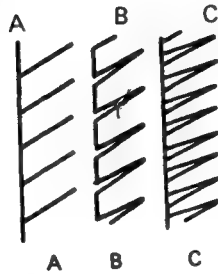

Length must be such as shown
in A on overcast sewing.

A Stretch Pattern.

ADJUSTMENT

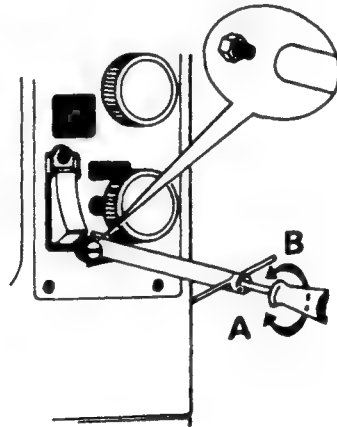

1. Loosen nut with socket wrench.
2. Put screwdriver into adjusting hole and turn screw in A or B direction.
3. Tighten nut with socket wrench.



Turn adjusting
screw (c) to-
ward A.



Turn adjusting
screw (c) to-
ward B.

NOTE

1. Check density of side stitch in buttonholing

Height of feed dog

TOOL



+ Philips screwdriver



Screw Driver Narrow Blade

PREPARATION

[No. 1]

Feed must be set in highest position

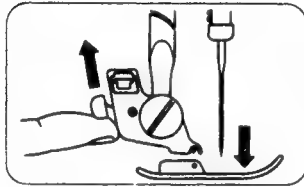

Remove Presser Foot

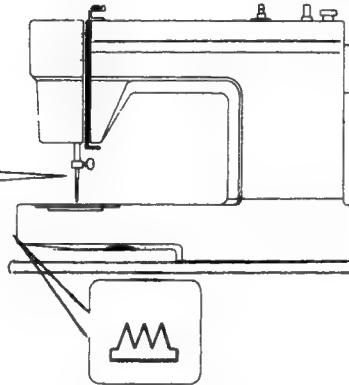

DIAGNOSIS

[No. 2]

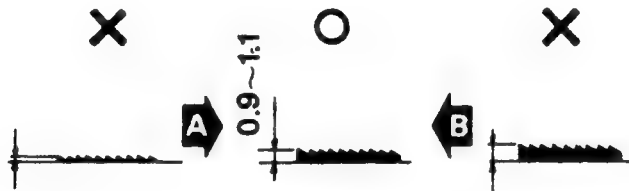

ADJUSTMENT

[No. 3]

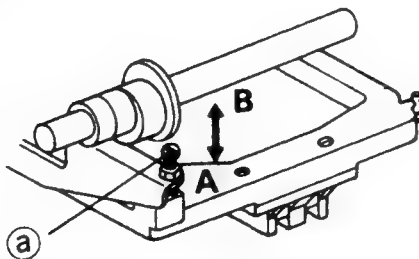

Adjust the height of the feed dog by turning screw ①.

Tension of upper thread

TOOL



95003

PREPARATION

[No. 1]

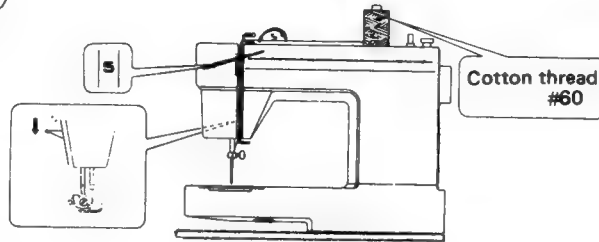

ADJUSTMENT

TIGHTEN **A** **B** LOOSEN
TENSION=120gr
(When #60 cotton thread)

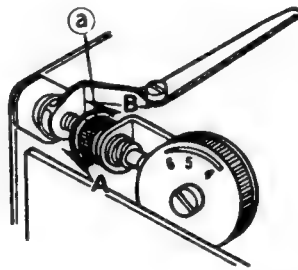

- (When using #60 cotton thread)
1. Set upper thread tension dial to "5".
 2. Measure tension of upper thread and turn adjustable nut in A or B direction.

NOTE:

Tension of lower thread

TOOL



– Screwdriver

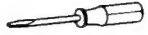

– Screwdriver



95003

PREPARATION

[No. 1]

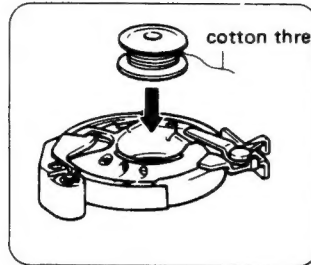

cotton thread #60

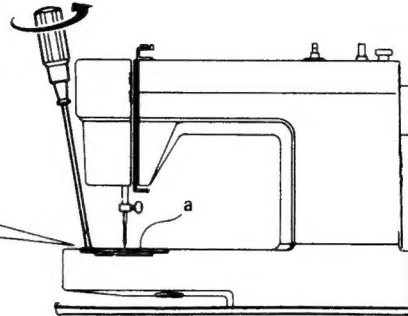

Remove needle plate
(a).

DIAGNOSIS

[No. 2]

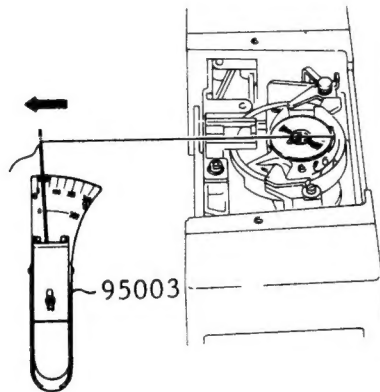

TENSION=16 ~ 21gr
(When #60 cotton thread)

ADJUSTMENT

[No. 3]

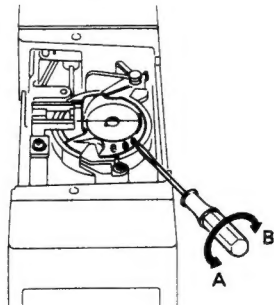

Turn adjusting screw toward
A, for decreasing the tension.

Turn adjusting screw toward
B for increasing the tension.

Tension of motor belt

TOOL

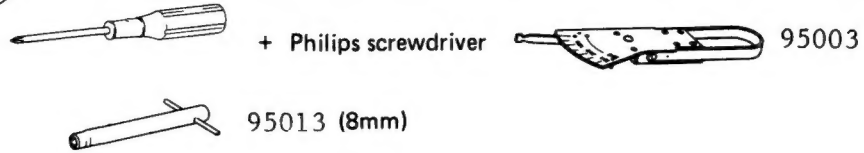

DIAGNOSIS

[No. 2]

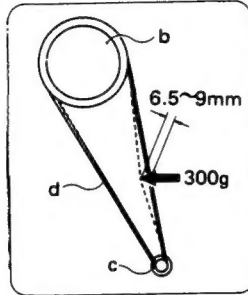

When a pressure of 300g is applied at the center between hand wheel (b) and motor pulley (c), the amount of bend of timing belt (d) should be between 6.5 and 9mm.

ADJUSTMENT

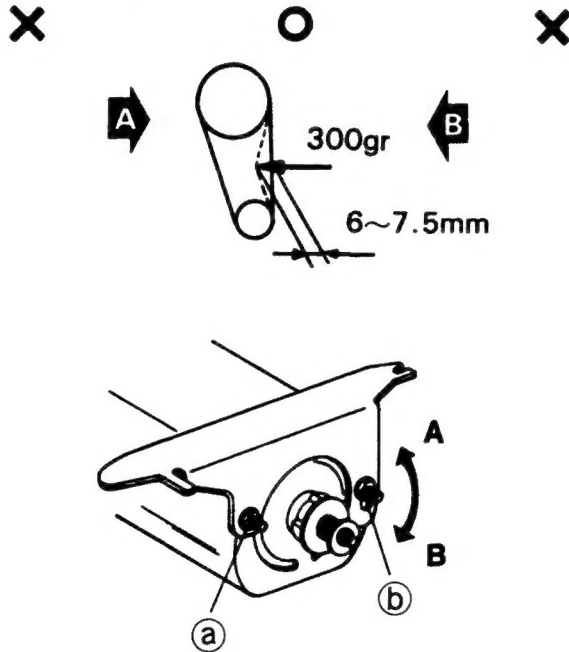

1. Loosen nut (a) .
2. Loosen nut (b) and move motor in A or B direction, with the tension of belt.
3. Tighten nut (b) .
4. Tighten nut (a) .

WARRANTY — WHITE SEWING MACHINE COMPANY

1. All mechanical parts warranted for a period of twenty (20) years.
2. Warranty to exclude electrical components, needles, belts, carrying case, and bobbin winder tires.
3. Warranties apply only to sewing machines used for normal personal, family or household purposes.
4. Warranties do not cover damages caused by ordinary wear and tear, or by accident, misuse, abuse, neglect or acts of God, or damages by repairs performed by unauthorized persons, or damage caused by failure to maintain the sewing machine in accordance with the manufacturer's instructions in the owner's manual.
5. Warranty does not apply for special incidental or consequential damages due to the failure of this product to conform to any express or implied warranty.
6. In order to obtain warranty, service part replacement, said part must be identified with model number and serial number. List of defective warranty parts must be sent to White Sewing Machine Company. White will replace all parts and disposition of parts will be made by White.

PART #95038
PRINTED IN U.S.A.