

Balanced Line Technology.

Updated: 26 July 2001

Go straight to new material: (in green)

[Mains earth and local ground](#) Section 3.

[More on unbalanced-to-balanced connections](#) Section 6.

[Home](#) [Back](#)

- **C O N T E N T S . O F . T H I S . P A G E**
- [1: Electronic vs Transformer Balancing.](#)
- [2: Balancing Basics.](#)
- [3: Electrical Noise.](#)
- [4: Line Outputs.](#)
- [5: Line Inputs.](#)
- [6: Input/Output Combinations.](#)
- [7: Grounding Philosophies.](#)
- [List of Diagrams.](#)
- [References.](#)

Balanced inputs and outputs have been used for many years in professional audio, but profound misconceptions about their operation and effectiveness still survive. As with many topics in audio technology, the conventional wisdom is sometimes wrong.

A practical balanced interconnect is not always wholly straightforward, for some new variations on input and output stages have emerged relatively recently. For example, a "ground-cancelling" output is not balanced at all, but actually has one output terminal configured as an input, which can come as a surprise to the unwary. Despite its non-balanced nature, such a ground-cancelling output can render a ground-loop innocuous even when driving an unbalanced input; but even an audio professional could be forgiven for being unsure if it still works when it is driving a balanced input. The answer (which in fact is yes) is explained in the section which evaluates the possible output/input combinations, of which there are at least ten. It describes the various kinds of balanced and unbalanced input and output circuits, how effectively they work together in various combinations, and how to connect them for the best results.

1: ELECTRONIC vs TRANSFORMER BALANCING.

Electronic balancing has many advantages, such as low cost, low size and weight, superior frequency and transient response, and no problems with low-frequency linearity. While it is sometimes regarded as a second-best, it is more than adequate for most professional applications. Transformer balancing has some advantages of its own, particularly for work in very hostile RF/EMC environments, but many serious drawbacks. The advantages are that transformers are electrically bullet-proof, retain their CMRR performance forever, and consume no power even at high signal levels. Unfortunately they also generate LF distortion, have HF response problems due to leakage reactance and distributed capacitance, and are heavy and expensive. The first two objections can be surmounted given enough extra electronic circuitry, but the last two cannot. Transformer balancing is therefore rare, even in professional audio, and is only dealt with briefly here.

[Top](#) | [Contents](#) | [Section 3](#)

2: THE BASICS OF BALANCING.

Balanced connections in an audio system are designed to reject both external noise, from power wiring etc, and also internal crosstalk from adjacent signal cables. The basic principle of balanced interconnection is to get the signal you want by subtraction, using a three-wire connection. In many

cases, one signal wire (the hot or in-phase) senses the actual output of the sending unit, while the other (the cold or phase-inverted) senses the unit's output-socket ground, and the difference between them gives the wanted signal. Any noise voltages that appear identically on both lines (ie common-mode signals) are in theory completely cancelled by the subtraction. In real life the subtraction falls short of perfection, as the gains via the hot and cold inputs will not be precisely the same, and the degree of discrimination actually achieved is called the Common-Mode Rejection Ratio, or CMRR.

"Hot" and "Cold" for in-phase and out-of-phase are used throughout this article for brevity.

While two wires carry the signal, the third is the ground wire which has the dual duty of both joining the grounds of the interconnected equipment, and electrostatically screening the two signal wires by being in some way wrapped around them. The "wrapping around" can mean:

- 1) A lapped screen, with wires laid parallel to the central signal conductor. The screening coverage is not perfect, and can be badly degraded as it tends to open up on the outside of cable bends.
- 2) A braided screen around the central signal wires. This is more expensive, but opens up less on bends. Screening is not 100%, but certainly better than lapped screen.
- 3) An overlapping foil screen, with the ground wire (called the drain wire in this context for some reason) running down the inside of the foil and in electrical contact with it. This is usually the most effective as the foil cannot open up on the outside of bends, and should give perfect electrostatic screening. However, the higher resistance of aluminium foil compared with copper braid means that RF screening may be worse.

ADVANTAGES OF BALANCING

- It discriminates against noise and crosstalk.
- A balanced interconnect (with a true balanced output) allows 6 dB more signal level on the line.
- Renders innocuous ground-loops, so that people are not tempted to start "lifting grounds" This tactic is only acceptable if the equipment has a dedicated ground-lift switch, that leaves the metalwork firmly connected to mains safety earth. In the absence of this facility, the optimistic will remove the mains earth (not quite so easy now that moulded plugs are standard) and this practice must be roundly condemned as DANGEROUS.

DISADVANTAGES OF BALANCING

- Balanced connections are unlikely to provide much protection against RF ingress- both sides of the balanced input would have to demodulate the RF with exactly the same effectiveness for common-mode cancellation to occur. This is not very likely.
- There are more possibilities for error when wiring up. For example, it is easy to introduce an unwanted phase inversion by confusing hot and cold in a connector, and this can go undiscovered for some time. The same mistake on an unbalanced system interrupts the audio completely.
- More hardware means more cost.

[Section 1](#) | [Contents](#) | [Section 4](#)

3: ELECTRICAL NOISE.

Noise gets into signal cables in three major ways:

- 1) Electrostatic coupling. An interfering signal with significant voltage amplitude couples directly to the inner signal line, through stray capacitance. The situation is shown in Fig 1, with C,C representing the stray capacitance between imperfectly-screened conductors; this will be a fraction of a pF in most circumstances. This coupling can be serious in studio installations with unrelated signals going down

the same ducting.

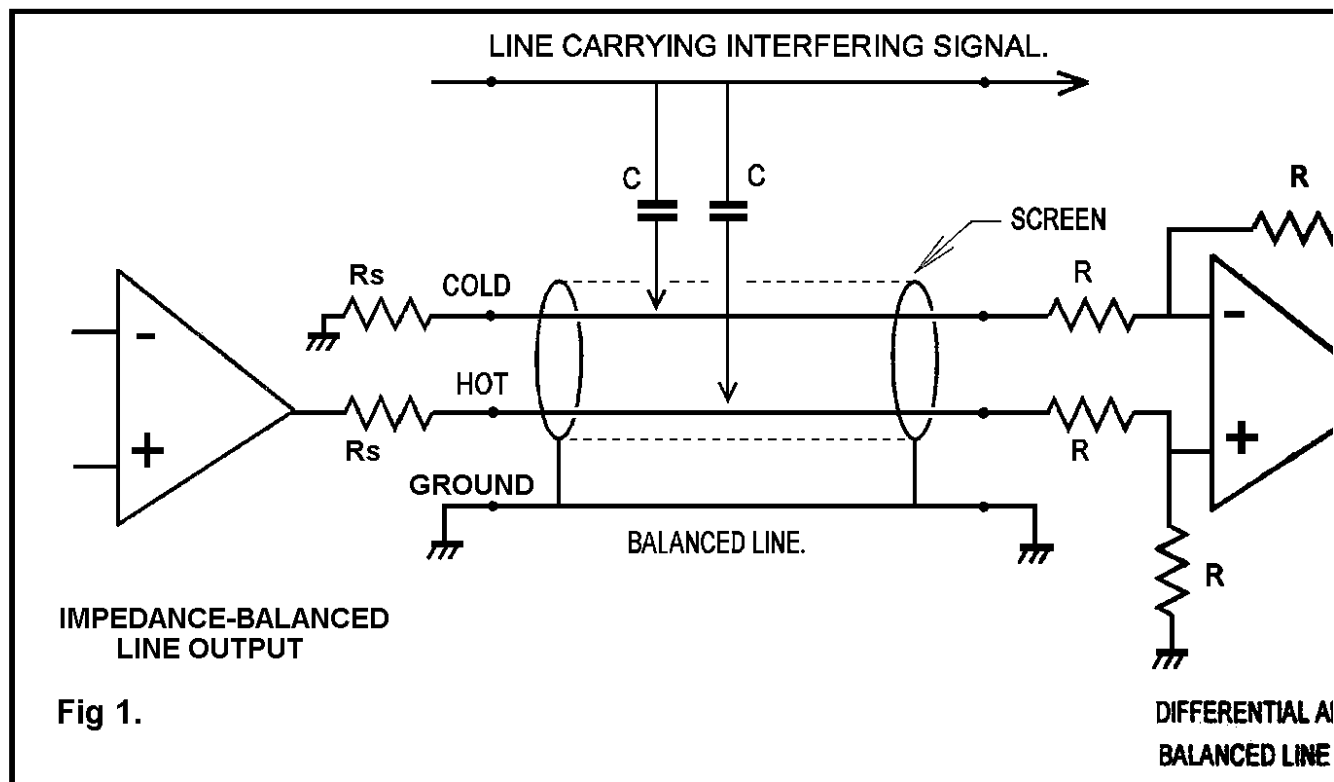

The two main lines of defense against electrostatic coupling are effective screening and low impedance drive. An overlapping foil screen (such as used on Belden microphone cable) provides complete protection. Driving the line from a low impedance, of the order of 100 Ohms or less, means that the interfering signal, having passed through a very small capacitance, is a very small current and cannot develop much voltage across such a low impedance. For the best effectiveness the impedance must remain low up to as high a frequency as possible; this can be a problem as op-amps invariably have a feedback factor that begins to fall from a low, and possibly sub-audio frequency, and this makes the output impedance rise with frequency. From the point of view of electrostatic screening alone, the screen does not need to be grounded at both ends, or form part of a circuit. [1] It must of course be grounded at some point. Electrostatic coupling falls off with the square of distance. Rearranging the cable-run away from the source of interference is more practical and more effective than trying to rely on very good common-mode rejection.

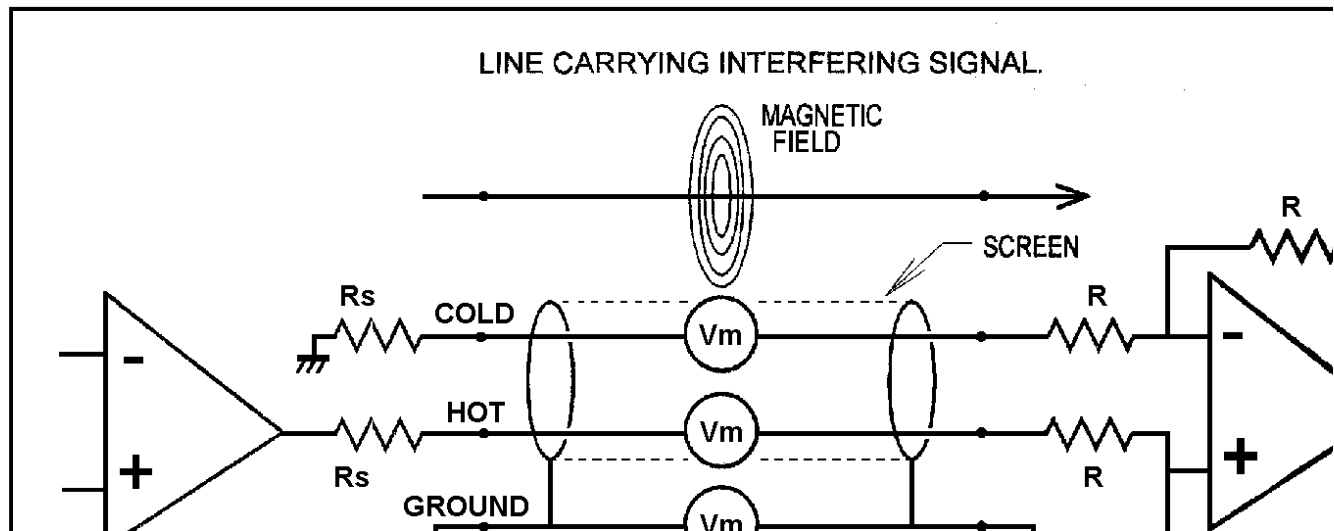

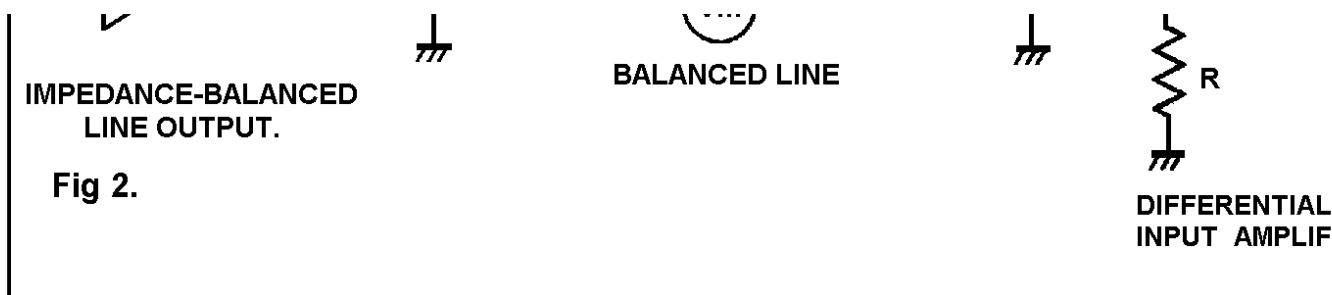

2) Magnetic coupling. See Fig 2 for an example. An EMF V_m is induced in both signal conductors and the screen, and according to some writers, the screen current must be allowed to flow freely or its magnetic field will not cancel out the field acting on the signal conductors, and therefore the screen should be grounded at both ends, to form a circuit. [2] In practice the field cancellation will be very imperfect and most reliance is placed on the common-mode rejection of the balanced system, to cancel out the hopefully equal voltages V_m induced in the two signal wires. The need to ground both ends for magnetic rejection is not a restriction, as it will emerge that there are other good reasons why the screens should be grounded at both ends of a cable.

In critical situations the equality of these voltages is maximised by minimising the loop area between the two signal wires, usually by twisting them tightly together. In practice most audio cables have parallel rather than twisted signal conductors, and this seems adequate most of the time. Magnetic coupling falls off with the square of distance, so rearranging the cable-run away from the source of magnetic field is usually all that is required. It is unusual for it to present serious difficulties in a domestic environment.

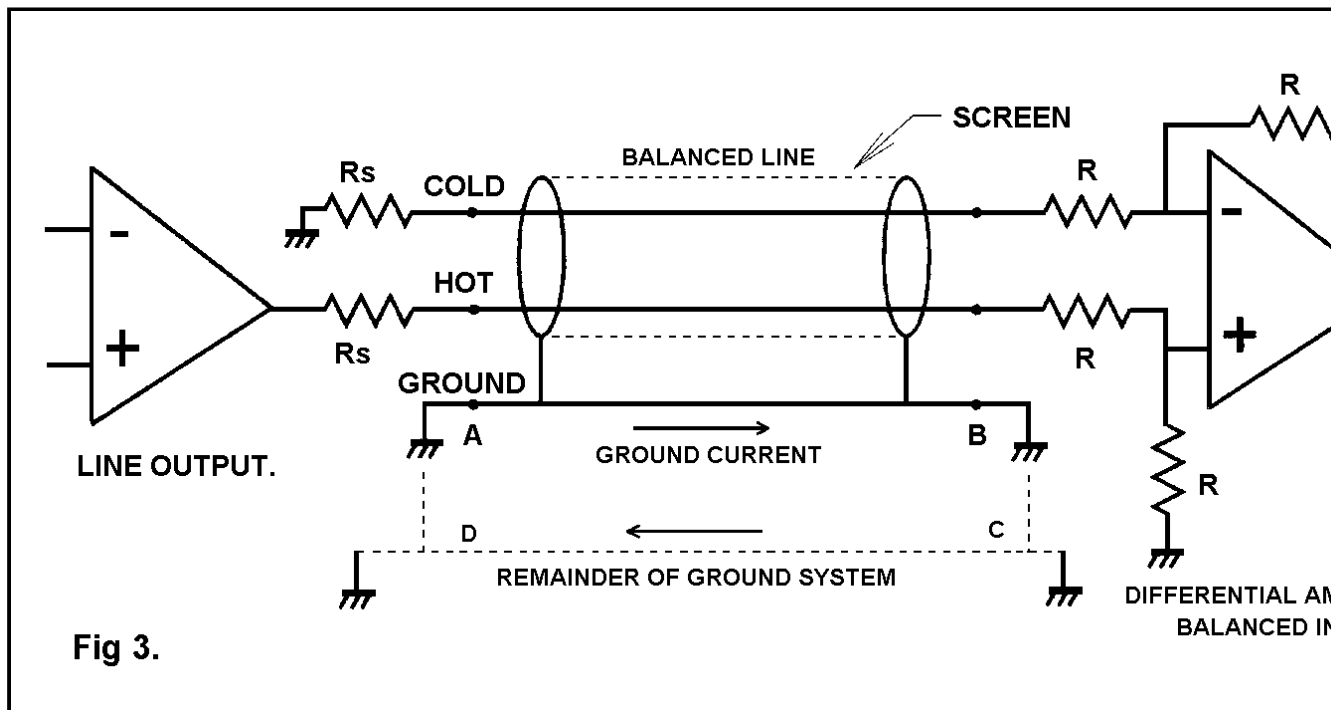

3) Ground voltages coupled in through the common ground impedance; often called "common-impedance coupling" in the literature. [3] This is the root of most ground loop problems. In Fig 3 the equipment safety grounds cause a loop ABCD; the mere existence of a loop in itself does no harm, but it is invariably immersed in a 50 Hz magnetic field that will induce mains-frequency current plus odd harmonics into it. This current produces a voltage drop down the non-negligible ground-wire resistance, and this once again effectively appears as a voltage source in each of the two signal lines. Since the CMRR is finite a proportion of this voltage will appear to be differential signal, and will be

reproduced as such.

The most common cause of ground-loop current is the connection of a system to two different "grounds" that are not actually at the same AC potential. The classic example of this is the addition of a "technical ground" such as a buried copper rod to a grounding system which is already connected to "mains ground" at the power distribution board. In many cases this "mains ground" is actually the neutral conductor, which is only grounded at the remote transformer substation. Power distribution (in the UK at least) is basically 3-phase, though only one phase and neutral enters domestic property. Since there is no separate earth wire this is called 4-wire distribution. The whole voltage-drop down the neutral, which can easily be 1 or 2 volts, therefore appears between "technical ground" and "mains ground" and can cause large currents to flow through ground wires. In my own house, 500mA flows from mains earth through the wire that bonds it to the water pipes. This is a little unsettling but seems to cause no harm.

In other cases, most commonly in commercial premises, 5-wire distribution is used, which does have a separate earth wire, joined to the neutral at the consumer cable head, and going back to ground at the substation. This is likely to reduce the voltage difference between mains ground and local copper-rod ground but it may not make it zero.

Note that supply distribution cables are almost always protected by wire armouring. This is invariably earthed, but is not necessarily used as an earth conductor to consumer's premises.

The best policy in all cases is to treat the mains earth as the reference point and not connect any audio system to any other version of ground.

A similar situation can occur when water-pipes are connected to "mains ground" except that interference is not usually by a common ground impedance; however the unwanted currents flowing in the pipework generate magnetic fields that may either create ground loops by induction, or interfere directly with equipment such as mixing consoles. In practice ground voltages cause a far greater number of noise problems than the other mechanisms.

Even if there is no common-impedance coupling (for example, if the balanced line is fully floating and not galvanically connected to ground- this is only possible with a transformer- to-transformer connection) ground currents may still enter the signal circuit by transformer action. The shield wire or foil acts as a transformer primary while the signal lines act as secondaries; if the magnetic field from the shield wire is not exactly uniform then a differential noise voltage appears across the signal pair and is amplified as if it were a genuine signal. This effect is often called Shield-Current- Induced-Noise (SCIN), and cables vary in their susceptibility to it according to the details of their construction. [4] It is fortunate that the level of this effect is below the noise- floor in most circumstances and with most cables, for once a differential-mode signal has been induced in the signal lines, there is no way to discriminate against it.

There are thus two principle effects to guard against; electrostatic coupling, and the intrusion of unwanted voltages from either magnetic coupling or ground-loop currents.

Electrostatic interference can be represented by notional current-sources connected to both signal lines; these will only be effectively cancelled if the line impedances to ground are the same, as well as the basic CMRR being high. The likely levels of electrostatic interference current in practice are difficult to guess at, so the figures I give here are calculated from applying 1 mA to each line; this would be very severe crosstalk, but it does allow convenient relative judgements to be made.

Magnetic and ground-voltage interference can be represented by notional voltage-sources inserted in both signal lines and the ground wire; these are not line-impedance sensitive and their rejection depends only on the basic CMRR, as measured with low-impedance drive to each input. Similarly ground- voltage interference can be represented by a voltage-source in the ground wire only. Both input and output are voltages so the CMRR can be quoted simply as a ratio in dB, without specifying any level.

[Section 2](#) | [Contents](#) | [Section 5](#)

4: LINE OUTPUTS.

A line output is expected to be able to drive significant loads, partly because of a purely historical

requirement to drive 600 Ohms, and partly to allow the parallel feed of several destinations. Another requirement is a low source impedance, (100 Ohms or less) to make the signal robust against capacitive crosstalk etc.

There are many line output and input arrangements possible, and the results of the various permutations of connection are not always entirely obvious. An examination of the output types in use yields Table 1:

TABLE 1: Output arrangements.

1. Unbalanced output.
2. Impedance-balanced output.
3. Ground-cancelling output. (or ground-compensated output)
4. Balanced output.
5. Quasi-floating output.
6. True floating transformer output.

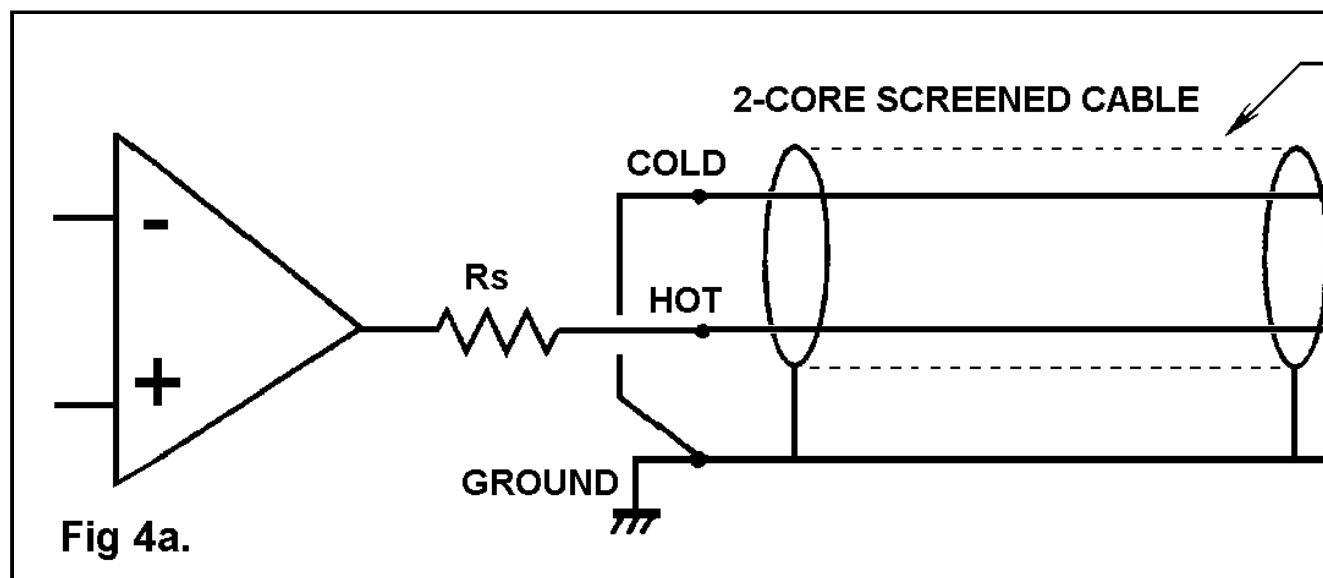

1) Unbalanced output. See Fig 4a.

There are only two physical output terminals- signal and ground. A third terminal is implied in Fig 4a, emphasising that it is always possible to connect the cold wire in the cable to the ground at the transmitting (output) end. The output amplifier is almost always buffered from the line shunt-capacitance by a resistor R_s in the range 33 - 100 Ohms, to ensure stability, and this unbalances the line impedances. If the output resistance is taken as 100 Ohms worst-case, and the cold line is simply grounded as in Fig 4a, then the presence of R_s degrades the CMRR to -46 dB even if the balanced input at the other end of the cable has perfectly matched resistors.

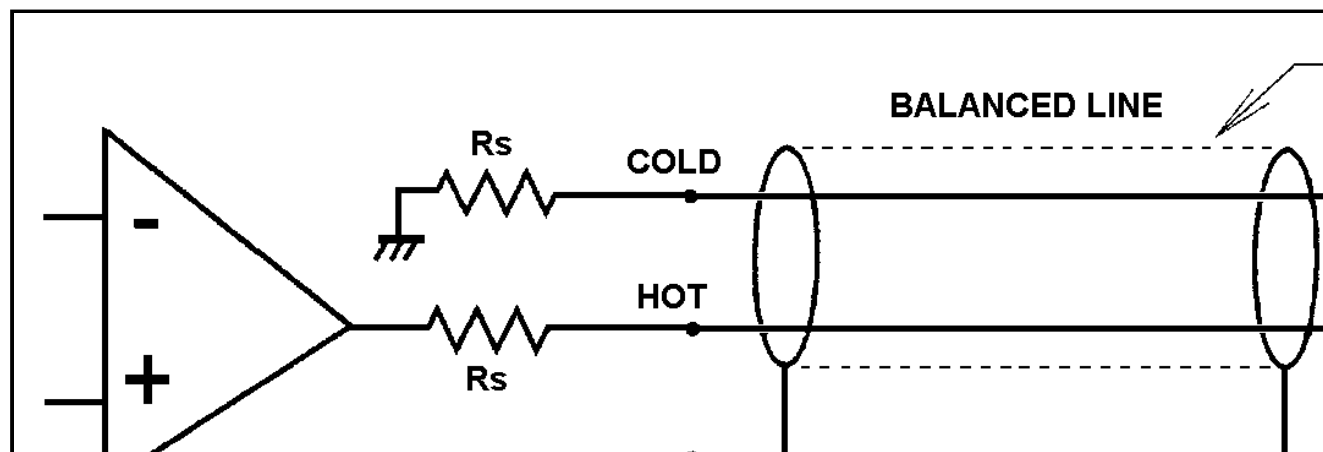

✓
Fig 4b.

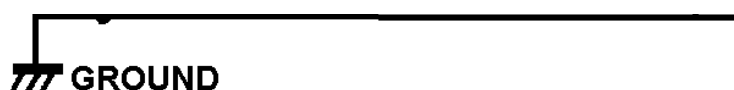

2) Impedance balanced output. See Fig 4b

There are now three physical terminals, hot, cold, and ground. The cold terminal is neither an input nor an output, but a resistive termination with the same resistance R_s as the hot terminal output impedance. This type of output is intended for use with receiving equipment having balanced inputs, and the presence of the second R_s terminated to output ground makes the impedance on each signal line almost exactly the same, (apart from op-amp output impedance limitations) so that good rejection is achieved for both common-mode ground voltages and electrostatic interference.

If an unbalanced input is being driven, the cold terminal on the transmitting (output) equipment can be either shorted to ground locally or left open-circuit without serious consequences, though either way all the benefits of balancing are lost.

The use of the word "balanced" is unfortunate as this implies anti-phase outputs, which are not present.

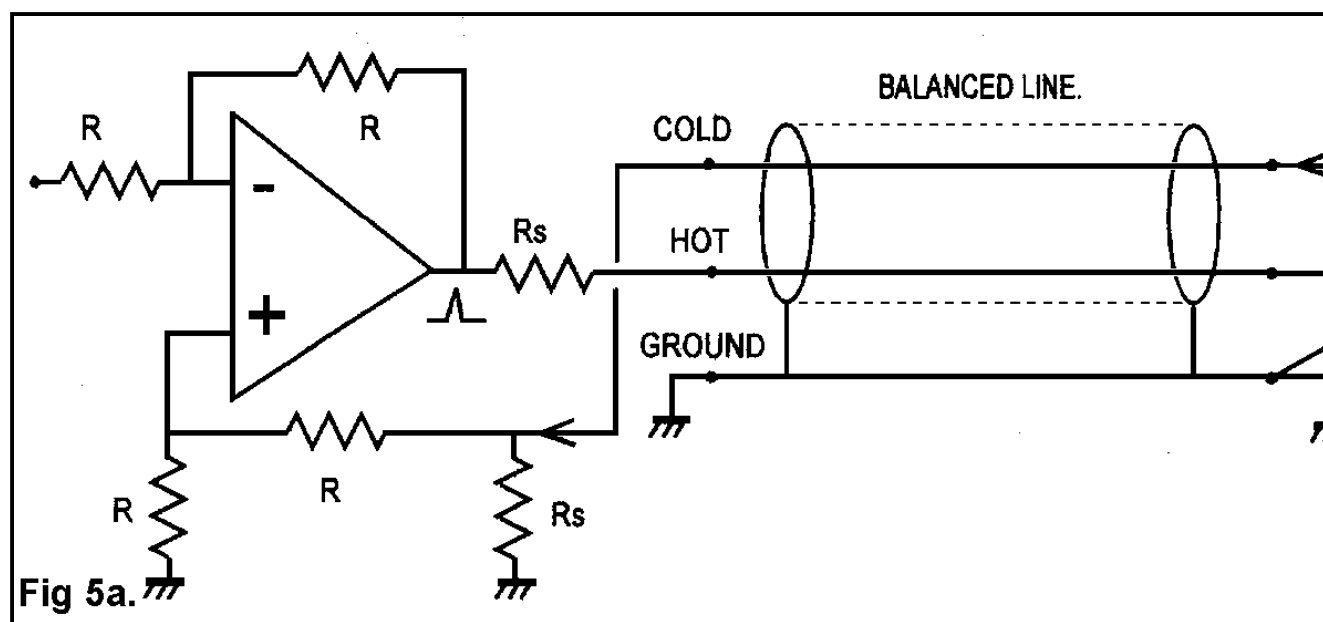

Fig 5a.

3) Ground-cancelling output. (also called a ground-compensated output) See Fig 5a.

This method allows ground voltages to be cancelled out even if the receiving equipment has an unbalanced input. It prevents any possibility of creating a phase error by miswiring. It separates the wanted signal from the unwanted by addition at the output end of the link, rather than by subtraction at the input end. If the receiving equipment ground differs in voltage from the sending ground, then this difference is added to the output so that the signal reaching the receiving equipment has the same voltage superimposed upon it. Input and ground therefore move together and there is no net input signal, subject to the usual CMRR tolerances.

The cold pin of the output socket is now an input, and must have a unity-gain path summing into the main signal output going to the hot output pin. It usually has a very low input impedance equal to the hot terminal output impedance.

It is unfamiliar to most people to have the cold pin of an output socket as a low impedance input, and this can cause problems. Shorting it locally to ground merely converts the output to a standard unbalanced type. If the cold input is left unconnected then there should be only a very small degradation of noise due to the very low input impedance of R_s .

Ground-cancelling outputs are an economical way of making ground-loops innocuous.

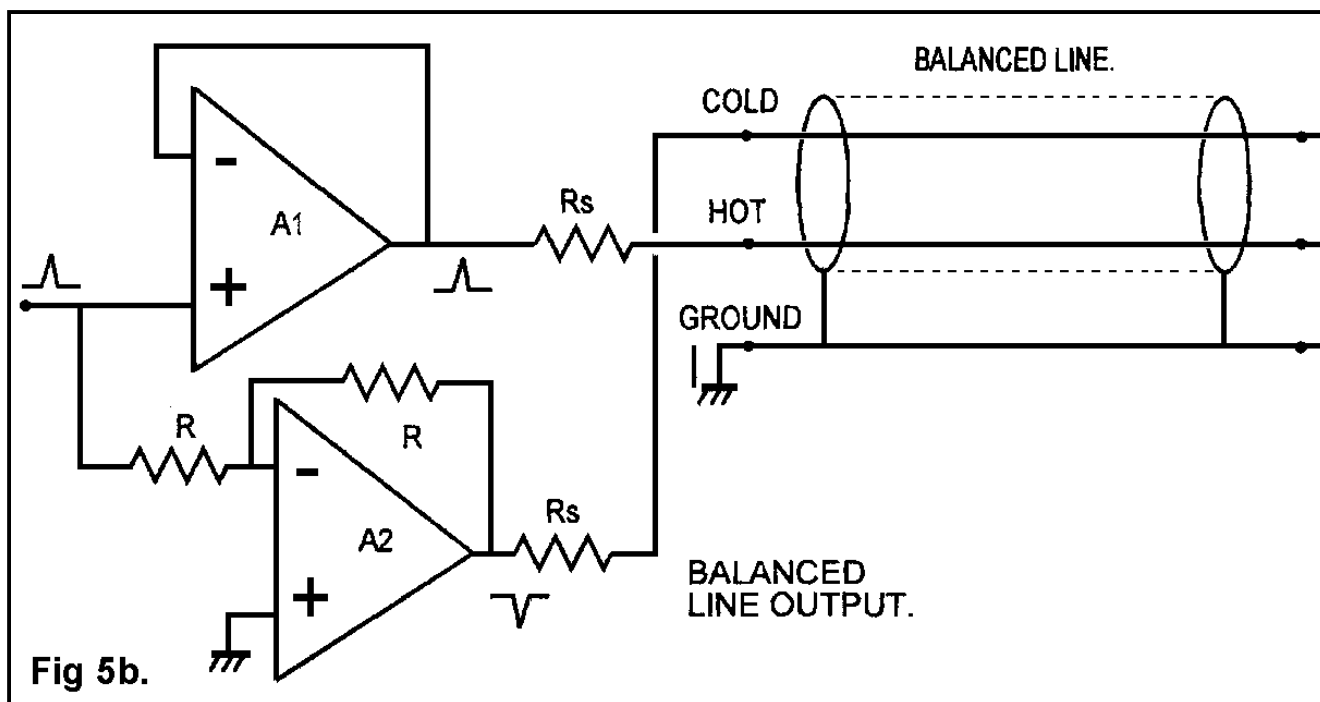

4) **Balanced output.** See Fig 5b. The cold terminal is now an active output, producing the same signal as the hot terminal but phase-inverted. This can be simply done by using an op-amp stage with a gain of minus one to invert the normal in-phase output. Phase spikes are shown on the diagram to emphasise these phase relationships.

The in-phase signal itself is not degraded by passing through an extra stage and this can be important in quality-critical designs. The inverting output must not be grounded; if not required it can simply be ignored. Unlike quasi-floating outputs, it is not necessary to ground the cold pin to get the correct gain for unbalanced operation, and it must not be grounded by mistake, because the inverting op-amp will then spend most of its time in current-limiting, probably injecting unpleasant distortion into the preamp grounding system, and possibly suffering unreliability. Both hot and cold outputs must have the same output impedance R_s to keep the line impedances balanced.

A balanced output has the advantage that it is unlikely to crosstalk to other lines even if they are unbalanced, as the current injected via the stray capacitance from each crosstalking line will cancel at the receiving end. Another advantage is that the total signal level on the line is increased by 6 dB, which can be valuable in difficult noise situations. All balanced outputs give the facility of correcting phase errors by deliberately swapping hot and cold outputs. This tactic is however a two-edged sword, because it is probably how the phase became wrong in the first place.

This form of balanced output is the norm in hi-fi balanced interconnection, but is less common in professional audio, where the quasi-floating output gives more flexibility.

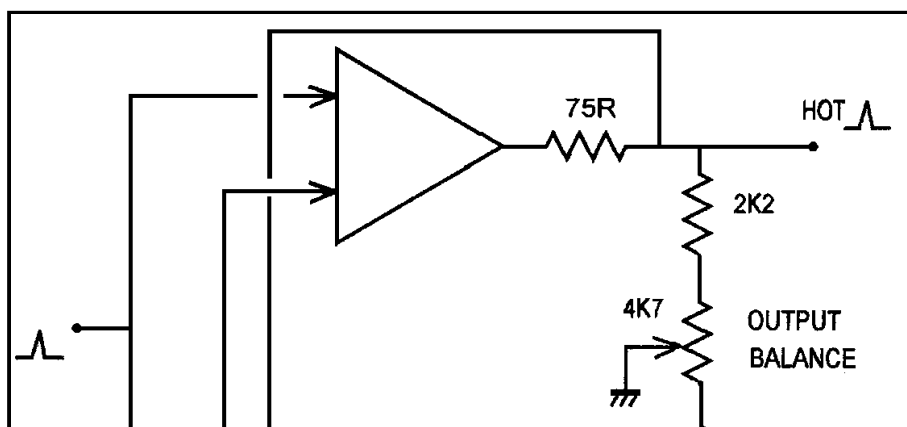

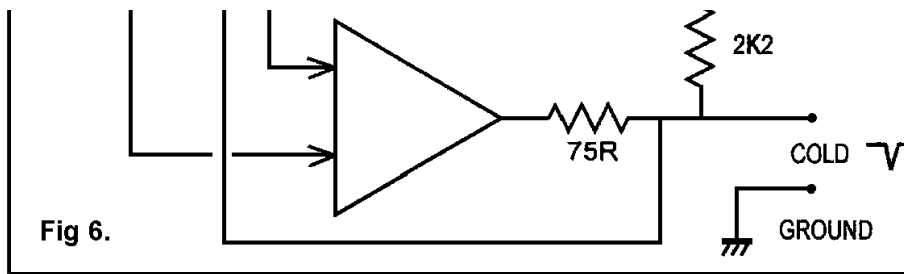

5) Quasi-floating output. See Fig 6.

This kind of output approximately simulates a floating transformer winding; if both hot and cold outputs are driving signal lines, then the outputs are balanced, as if a centre-tapped output transformer were being used. If, however, the cold output is grounded, the hot output doubles in amplitude so the total level is unchanged. This condition is detected by the current-sensing feedback taken from the outside of the 75R output resistors, and the current driven into the shorted cold output is automatically reduced to a low level that will not cause problems.

Similarly, if the hot output is grounded, the cold output doubles in amplitude and remains out of phase; the total hot-cold signal level is once more unchanged. This system has the advantage that it can give the same level into either a balanced or unbalanced input without rewiring connectors. 6 dB of headroom is however lost.

When an unbalanced output is being driven, the quasi-floating output can be wired to work as a ground-cancelling connection, with rejection of ground noise no less effective than the true balanced mode. This requires the cold output to be grounded at the remote (input) end of the cable. Under adverse conditions this might cause HF instability, but in general the approach is sound. If you are using exceptionally long cable, then it is wise to check that all is well.

If the cold output is grounded locally, ie at the sending end of the cable, then it works as a simple unbalanced output, with no noise rejection. When a quasi-floating output is used unbalanced, the cold leg must be grounded, or common-mode noise will degrade the noise floor by at least 10 dB, and there may be other problems.

In both of the unbalanced cases the maximum signal possible on the line is reduced by 6 dB.

Quasi-floating outputs use a rather subtle circuit with an intimate mixture of positive and negative feedback of current and voltage. This performs the required function admirably; its only drawback is a tendency to accentuate circuit tolerances, and so a preset resistor is normally required to set the outputs for equal amplitude; the usual arrangement is shown in Fig 6. If the balance preset is not correctly adjusted one side of the output will clip before the other and reduce the total output headroom. After factory setting this preset should not need to be touched unless the resistors in the circuit are replaced; changing the opamp should make no difference. The balancing network consists of a loading resistor to ground on each output; in this respect the output characteristics diverge from a true floating output, which would be completely isolated from ground. These loading resistors are lower than the input impedance of typical balanced inputs, so if simple differential amplifiers are used with unequal input impedances, (see the section on line inputs, below) the output balance is not significantly disturbed and clipping remains symmetrical on the hot and cold outputs.

Quasi-floating outputs are often simply referred to as "balanced" or "electronically-balanced", but this risks serious confusion as the true balanced output described in 4) above must be handled in a completely different way from quasi-floating.

6) True floating transformer output.

This can only be implemented with a transformer if galvanic isolation from ground is required. The technique is rarely used, because of the cost, weight, and performance problems of transformers, but is sometimes found in touring PA systems (usually only in the mic-splitter box on the stage) and broadcast environments where enormous RF field strengths are encountered.

[Section 3](#) | [Contents](#) | [Section 6](#)

5: LINE INPUTS.

There are only two kinds of input stage- unbalanced and balanced. For interconnection this is the primary distinction.

Apart from balancing requirements, a line-level input, as opposed to a microphone input, is expected to have a reasonably high impedance to allow multiple connections to a single output. Traditionally a "bridging impedance"- ie high enough to put negligible loading on historical 600 Ohm lines- was 10K minimum, and this is still appropriate for modern low- impedance outputs. However, a higher impedance of 100K or even more is desirable for interfacing to obsolete valve equipment, to avoid increased distortion and curtailed headroom.

Another common requirement is true variable gain at the balanced input, as putting the gain control further down the signal path means that it is impossible to prevent input amplifier overload. Thus we need a balanced stage that can attenuate as well as amplify, and this is where the circuit design starts to get interesting. In the following circuitry, small capacitors often shunt the feedback elements to define bandwidth or ensure stability. These are omitted for clarity.

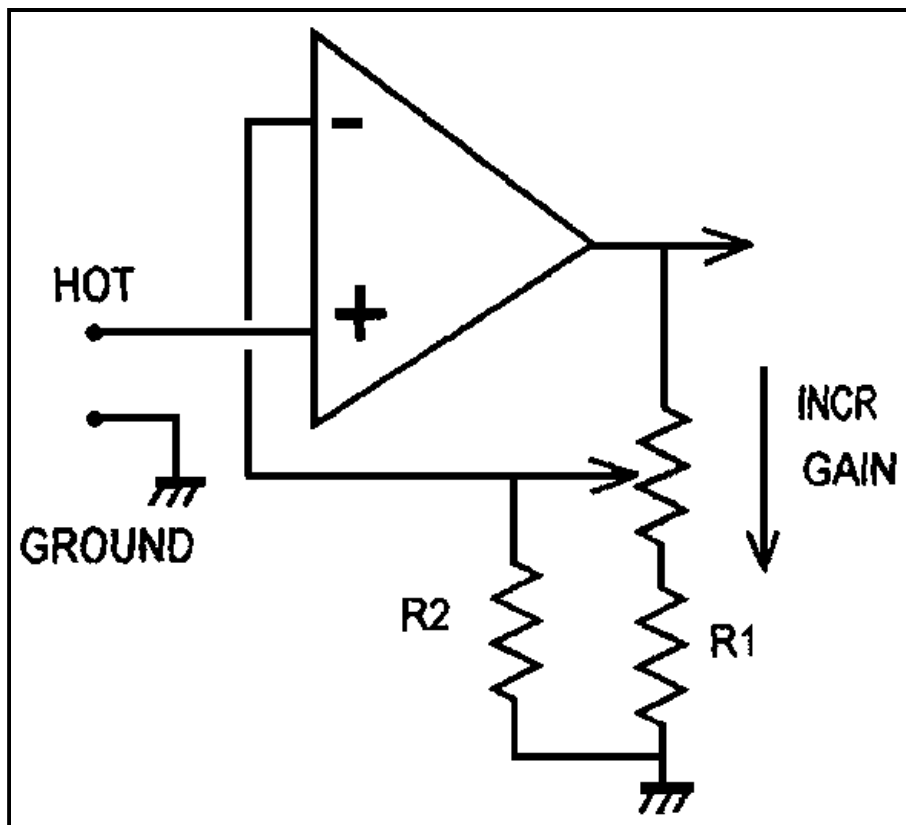

1) Unbalanced inputs. These are straightforward; variable-gain series-feedback stages are easily configured as in Fig 7, providing a minimum gain of unity is acceptable; R2 sets the gain law in the middle of the pot travel. It is also simple to make a stage that will attenuate as well as amplify, but this implies a shunt-feedback configuration as in Fig 8, with a variable input impedance. The minimum input impedance R1 cannot be much higher than 10k or resistor noise becomes excessive.

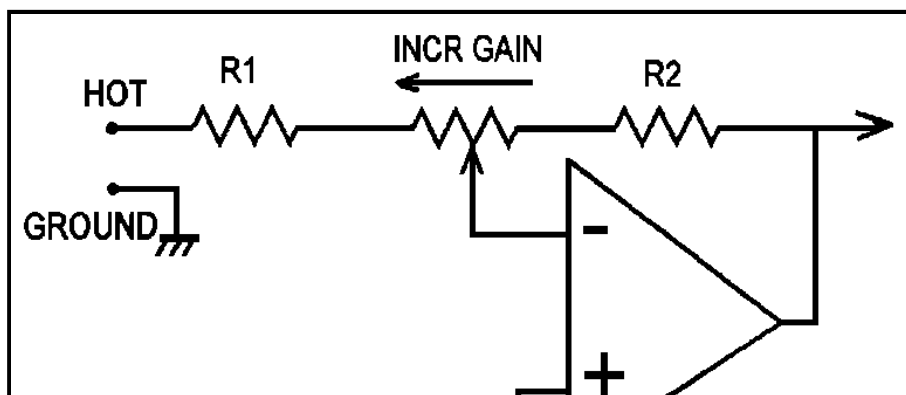



For a series-feedback stage, the input impedance can be made as high as desired by bootstrapping; an input resistance of 500k or greater is perfectly possible, and does not imply a poorer noise performance, as this depends on the source resistance and semiconductor characteristics. To ram the point home, my own personal best is 1 GOhm, in a capacitor microphone head amplifier. Although the input impedance is many orders of magnitude greater than the 1 to 2 k of a dynamic mic preamp, the EIN is -110 dBu, ie only 18 dB worse.

Naturally, any unbalanced input can be made balanced or floating by adding a transformer.

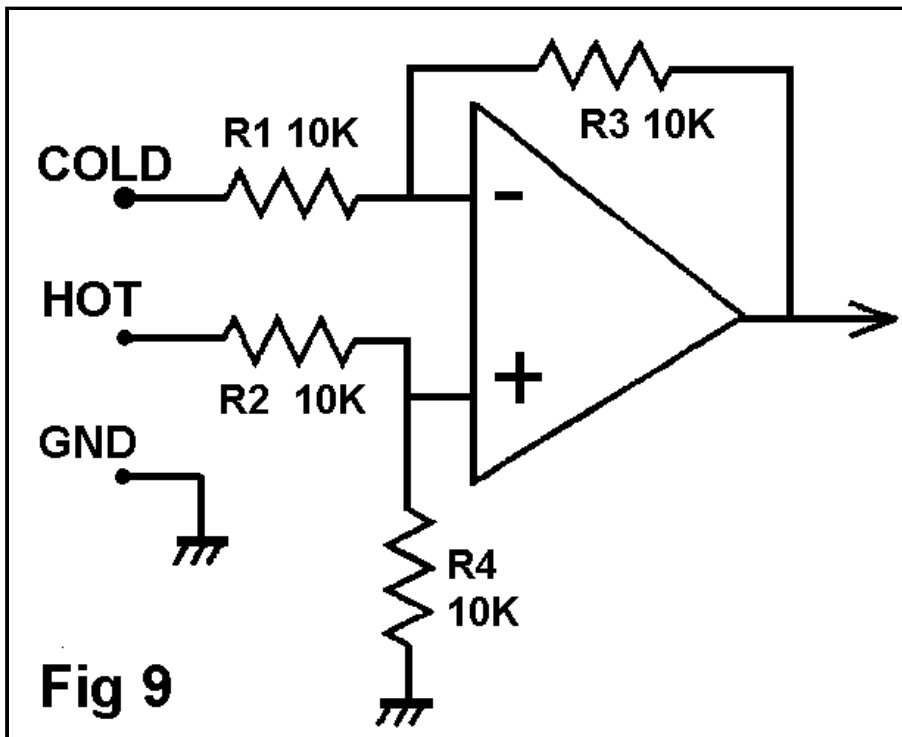

2) Balanced inputs. A standard one-op-amp differential input stage is shown in Fig 9. Unlike instrumentation work, a super-high CMRR is usually unnecessary. Ordinary 1% resistors and no trimming will not give CMRR better than 45 dB; however this is usually adequate for even high-quality audio work.

It is never acceptable to leave either input floating, as this will cause serious deterioration of noise, hum etc. Grounding the cold input locally to create an unbalanced input is quite alright, though naturally all the balanced noise rejection is lost. The hot input can be locally grounded instead, and the cold input driven, to create a phase-inverting input that will correct a phase error elsewhere, but this is not good practice- the right thing to do is to sort out the original phase error.

BALANCED INPUT TECHNOLOGIES.

There are many, many ways to make balanced or differential input amplifiers, and only the most important in audio are considered. These are:

TABLE 2.

1)	The standard differential amplifier.	Fig 9
2)	Switched-gain balanced amp.	Fig 10
3)	Variable-gain balanced amp.	Fig 11
4)	The "Superbal" amp.	Fig 12
5)	Hi-Z balanced amp.	Fig 13
6)	Microphone preamp plus attenuator	Fig 14
7)	Instrumentation amp.	

1) The standard one-opamp differential amplifier is a very familiar circuit block, but its operation often appears somewhat mysterious. The version in Fig 9 has a gain of $R3/R1$. ($=R4/R2$) It appears to present inherently unequal input impedances to the line; this has often been commented on, [5] and some confusion has resulted. The root of the problem is that a simple differential amplifier has interaction between the two inputs, so that the input impedance on the cold input depends strongly on the signal applied to the hot input. Since the only way to measure input impedance is to apply a signal and see how much current flows into the input, it follows that the apparent input impedance on each leg varies according to the way the inputs are driven. If the amplifier is made with four 10K resistors, then the input impedances Z are:

TABLE 3: Differential amplifier input impedances.

	Case	HOT i/p Z	COLD i/p Z
1.	Hot only driven	20k	Grounded
2.	Cold only driven	Grounded	10k
3.	Both driven balanced	20k	6.7k
4.	Both driven CM, ie together	20k	20k
5.	Both driven floating	10k	10k

Some of these impedances are not exactly what you would expect. In Case 3, where the input is driven as from a transformer with its centre-tap grounded, the unequal input impedances are often claimed to "unbalance the line". However, since it is common-mode interference we are trying to reject, the CM impedance is what counts, and this is the same for both inputs. The vital point is that the line output amplifier will have output impedances of 100 Ohms or less, completely dominating the line impedance. These input impedance imbalances are therefore of little significance in practice; audio connections are not transmission lines (unless they are telephone circuits several miles long) so the input impedances do not have to provide a matched and balanced termination.

The low impedance of 6.7k on the cold input sounds impossible as the first thing the signal encounters is a 10k series resistor, but the crucial point is that the hot input is driven simultaneously, so the inverting op-amp input is moving in the opposite direction to the cold input, due to negative feedback, a sort of anti-bootstrapping that reduces the effective value of the 10k resistor to 6.7k. The input impedances in this mode can be made equal by manipulating resistor values, but this makes the CM impedances (to ground) unequal, which seems more undesirable.

In Case 5, where the input is driven as from a floating transformer with any centre-tap unconnected, the impedances are nice and equal; they must be, because with a floating winding the same current must flow into each input. However, in this connection the line voltages are not equal and opposite: with a true floating transformer winding the hot input has all the signal voltage on it while the cold has none at all, due to the internal coupling of the balanced input amplifier. This seemed very strange when it emerged from simulation, but a reality-check proved it true. The line has been completely unbalanced as regards talking to other lines, although its own common-mode rejection remains good. Even if perfectly matched resistors are assumed, the CMRR of this stage is not infinite; with a TL072 it is about -90 dB, degrading from 100 Hz upwards, due to the limited open-loop gain of the opamp.

2: The need for a balanced input stage with two switched gains crops up frequently. The classic application is a mixing desk to give optimum performance with both semi-pro (-7.8 dBu) and professional (+4 dBu) interface levels. Since the nominal internal level of a mixer is usually in the range -4 to 0 dBu, the stage must be able to switch between amplifying and attenuating, maintaining good CMRR in both modes.

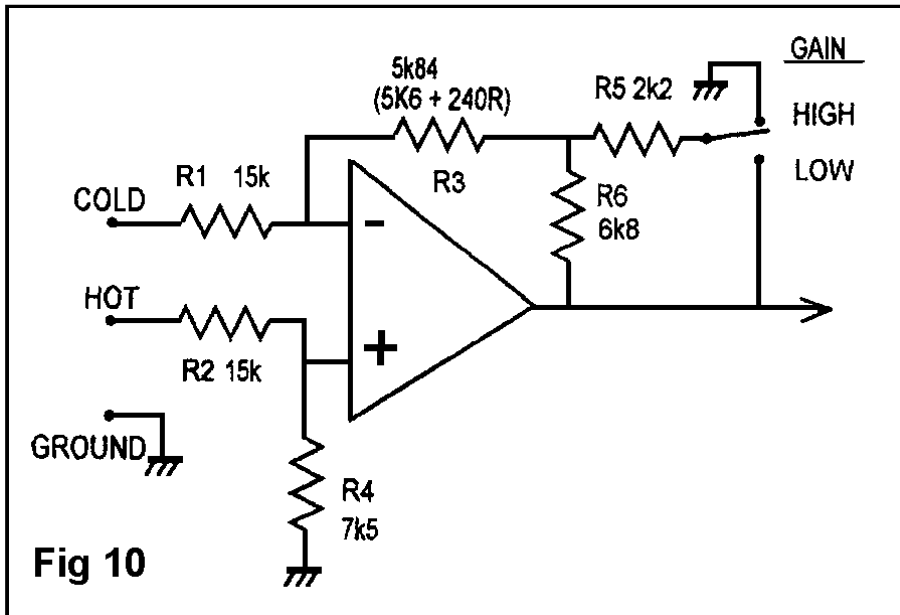

The obvious way to change gain is to switch both R3,R4 in Fig 9, but a neater technique is shown in Fig 10. Perhaps surprisingly, the gain of a differential amplifier can be manipulating by changing the drive to the feedback arm (R3 etc) only, without affecting the CMRR. The vital point is to keep the resistance of this arm the same, but drive it from a scaled version of the opamp output. Fig 10 uses the network R5,R6, which has the same 2k output impedance whether R4 is switched to the output (low gain) or ground (high gain). For low gain the feedback is not attenuated, but fed through R5,R6 in parallel. For high gain R5,R6 become a potential divider. R3 is reduced by 2k to allow for the R5,R6 output impedance. The stage can attenuate as well as amplify if R1 is greater than R3, as shown here. The nominal output of the stage is assumed to be -2 dBu; the two gains are -6.0 and +6.2 dB. The differential input impedance is 11.25k via the cold and 22.5k via the hot input. Common mode input impedance is 22.5k for both inputs.

3: A variable-gain balanced input should have its gain control at the very first stage, so overload can always be avoided. Unfortunately, making a variable-gain differential stage is not so easy; dual pots can be used to vary two of the resistances, but this is clumsy and will give shocking CMRR due to pot mismatching. For a stereo input the resulting 4-gang pot is unattractive. The gain-control principle is essentially the same as for the switched-gain amplifier above. To the best of my knowledge I invented both stages in the late 70s, but so often you eventually find out that you have re-invented instead; any comments welcome. The feedback arm R3 is of constant resistance, and is driven by voltage-follower A2. This eliminates the variations in source impedance at the pot wiper, which would badly degrade CMRR. As in Fig 7, R6 modifies the gain law; however, the centre-detent gain may not be very accurate as it partly depends on the ratio of pot track (often no better than +/- 10%, and sometimes worse) to 1% fixed resistors.

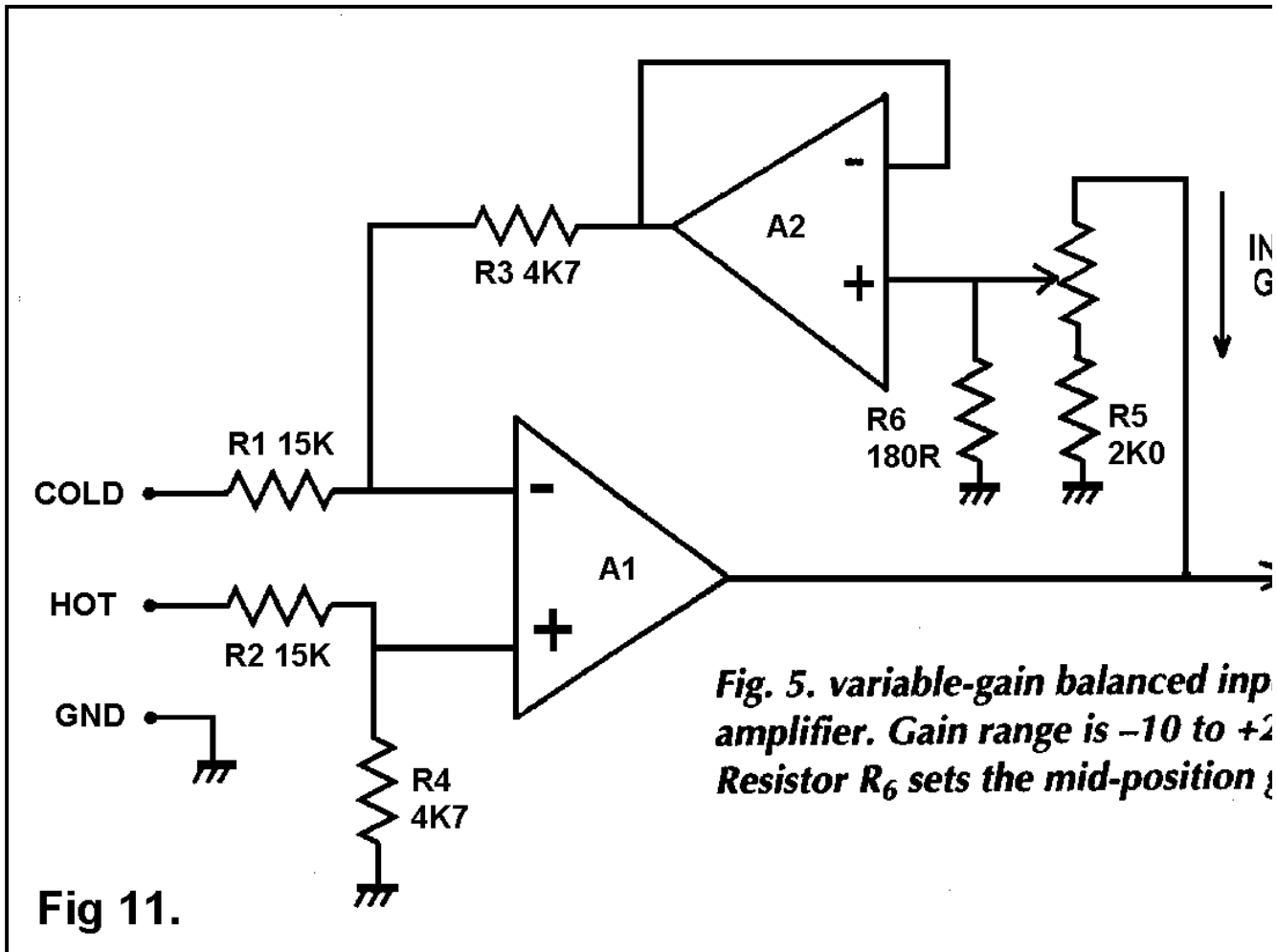

This stage is very useful as a general line input with an input sensitivity range of -20 to +10 dBu. For a nominal output of 0 dBu, the gain of Fig 11 is +20 to -10 dB, with R₆ chosen for 0 dB at the central wiper position.

An opamp in a feedback path appears a dubious proposition for stability, but here, working as a voltage-follower, its bandwidth is maximised and in practice the circuit is dependably stable.

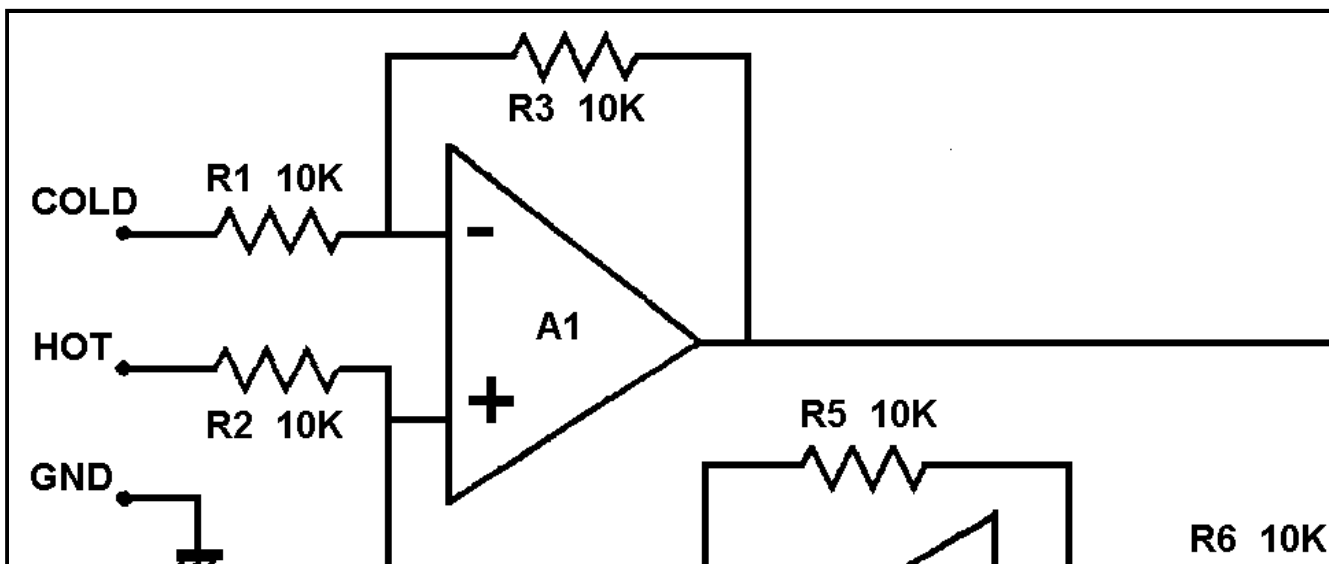

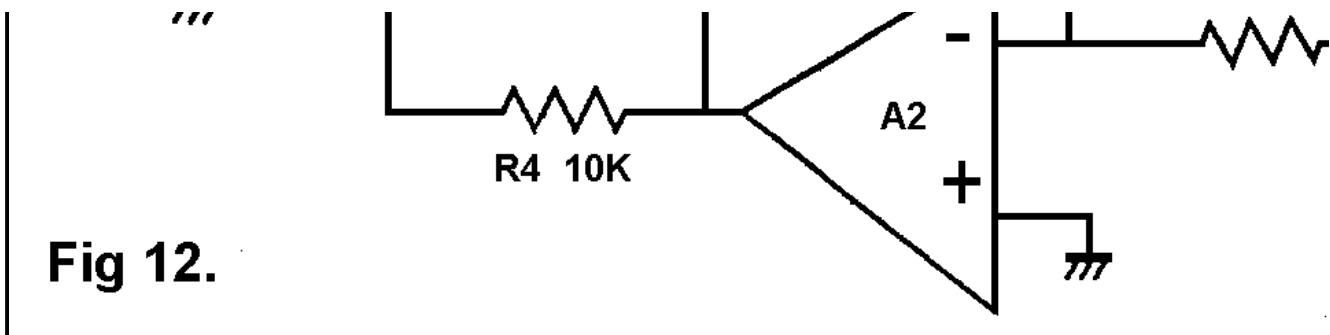

4: The "Superbal" configuration [6] gives much better input symmetry than the standard differential amplifier. The differential input impedance is exactly 10k via both hot and cold inputs. Common mode input impedance is 20k for both inputs. This configuration is less easy to modify for variable gain.

5: High-impedance (above 10K) balanced inputs are useful for interfacing to valve equipment. Adding output cathode- followers to valve circuitry is expensive, and so the output is often taken directly from a gain-stage anode. Even a light loading of 10K may seriously compromise distortion and available output swing.

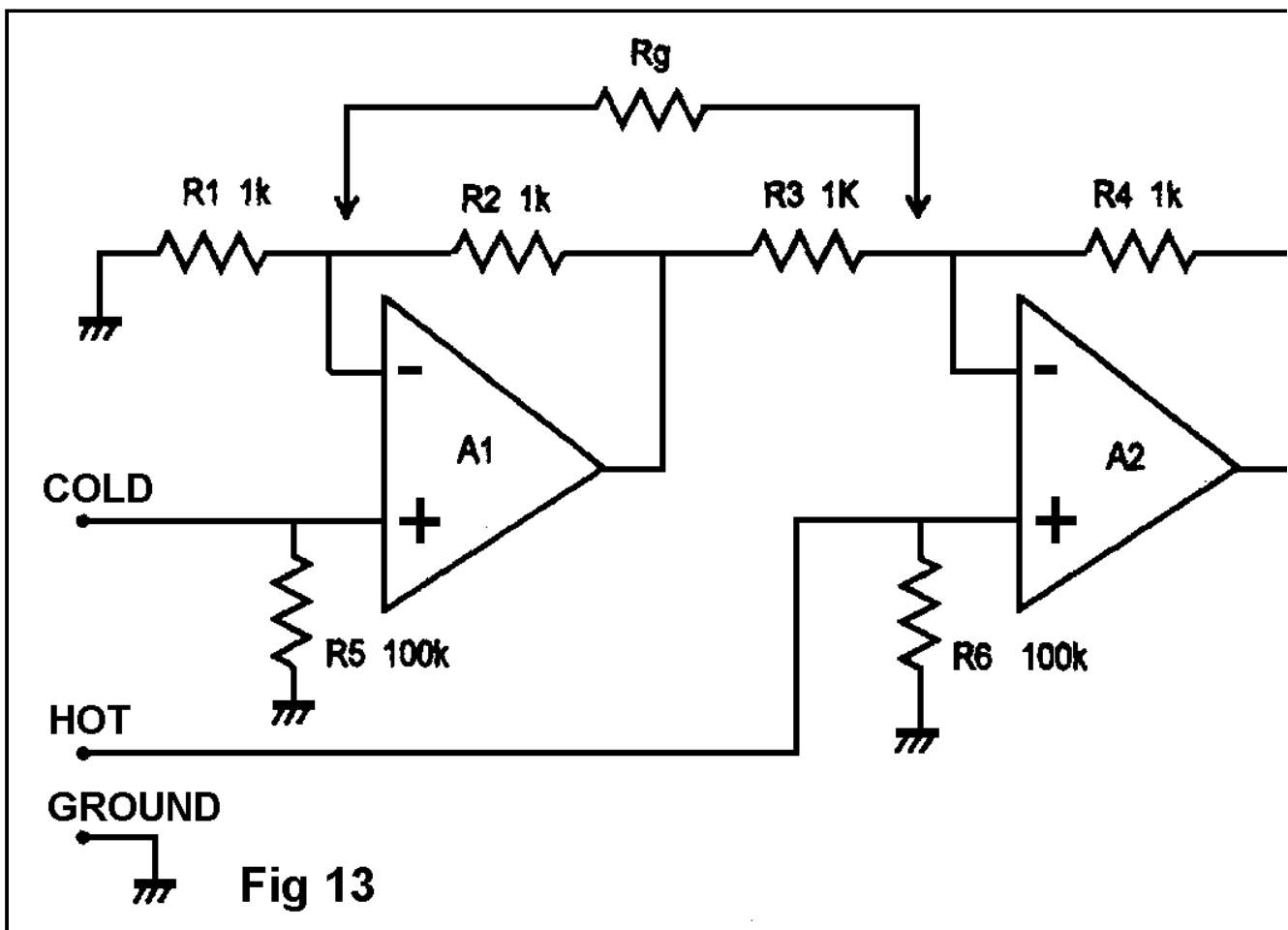

All of the balanced stages dealt with up to now have their input impedances determined by the values of input resistors etc, and these cannot be raised without degrading noise performance. Fig 13 shows one answer to this. The op-amp inputs have infinite impedance in audio terms, subject to the need for R,R to bias the non-inverting inputs. [7] Adding Rg increases gain, but preserves balance. This configuration cannot be set to attenuate.

6: It is often convenient to use a balanced microphone preamp as a line input by using a suitable balanced attenuator, typically 20 to 30 dB. The input impedance of the mic input stage will be 1 to 2K for appropriate mic loading, and this constrains the resistor values possible. Keeping the overall input impedance to at least 10K means that the divider impedance must be fairly high, with a lot of Johnson noise, so the total noise performance balanced is almost always inferior to a dedicated line input amplifier. CMRR is determined by the attenuator tolerances and will probably be much inferior to the basic mic amp, which usually relies on inherent differential action rather than component matching. Fig 14a shows a bad way to do it; the differential signal is attenuated, but not the common-mode, so CMRR is degraded even if the resistors are accurate. Fig 14b attenuates differential and common-mode signals by the same amount, so CMRR is preserved, or at any rate no worse than resistor tolerances make it.

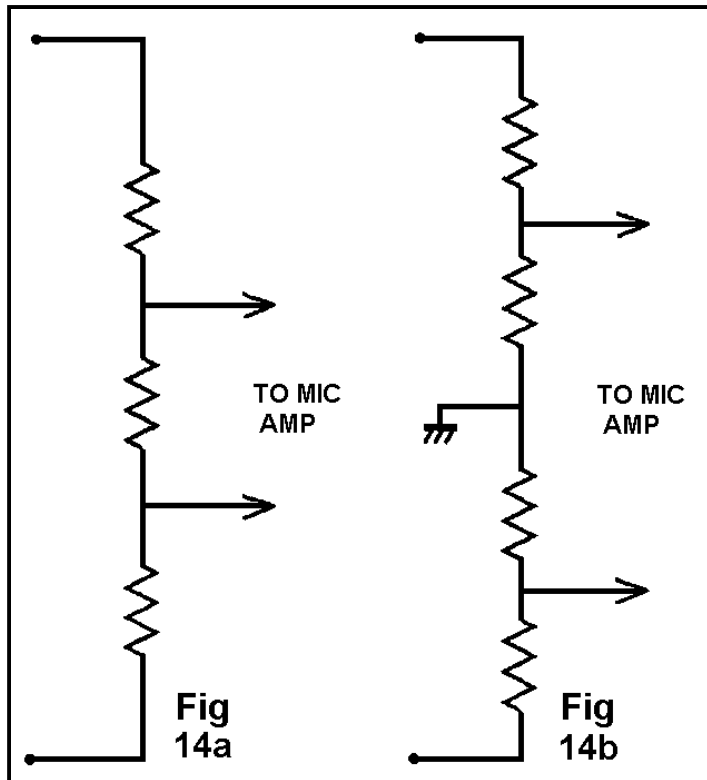

7: All the balanced inputs above depend on resistor matching to set the CMRR. In practice this means better than 45 dB is not obtainable without trimming. If CMRR higher than this is essential, an IC instrumentation amplifier is one possibility; CMRR can be in the range 80 to 110 dB, without trimming or costly precision components. The IC tends to be expensive, due to low production volumes. Gain is often limited in range and cannot usually be less than unity. CMRR of this order is rarely if ever required in audio work. If the interference is that serious, then it will be better to eliminate the source of the noise rather than its effects.

[Section 4](#) | [Contents](#) | [Section 7](#)

6: INPUT/OUTPUT COMBINATIONS Taking five kinds of output (the rare case of floating output transformers being excluded) and the two kinds of input amplifier, there are 10 possible combinations of connection. The discussion below assumes output R_s is 100 Ohms, and the differential input amplifier resistors R are all 10k, as in Fig 9.

Case 1) Unbalanced output TO unbalanced input. The basic connection. There is no rejection of ground noise (CMRR=unity) or electrostatic crosstalk; in the latter case the 1mA notional crosstalk

signal yields a -20 dBv signal as the impedance to ground is very nearly 100 Ohms.

Case 2) Unbalanced output TO balanced input.

Assuming the output ground is connected to the cold line input, then in theory there is complete cancellation of ground voltages- unless the output has a series output resistor to buffer it from cable capacitance, (which is almost always the case) for this will unbalance the line. If the output resistance is 100 Ohms, and the cold line is simply grounded as in Fig 4a, then R_s degrades the CMRR to -46 dB even if the balanced input has exactly matched resistors.

The impedances on each line will be different, but not due to the asymmetrical input impedances of a simple differential amplifier; the hot line impedance is dominated by the output resistance R_s on the hot terminal (100 Ohms) and the cold line impedance is zero as it is grounded at the output end. The rejection of capacitive crosstalk therefore depends on the unbalanced output impedance, and will be no better than for an unbalanced input, as at 1); the main benefit of this connection is ground noise rejection, which solves the most common system problem.

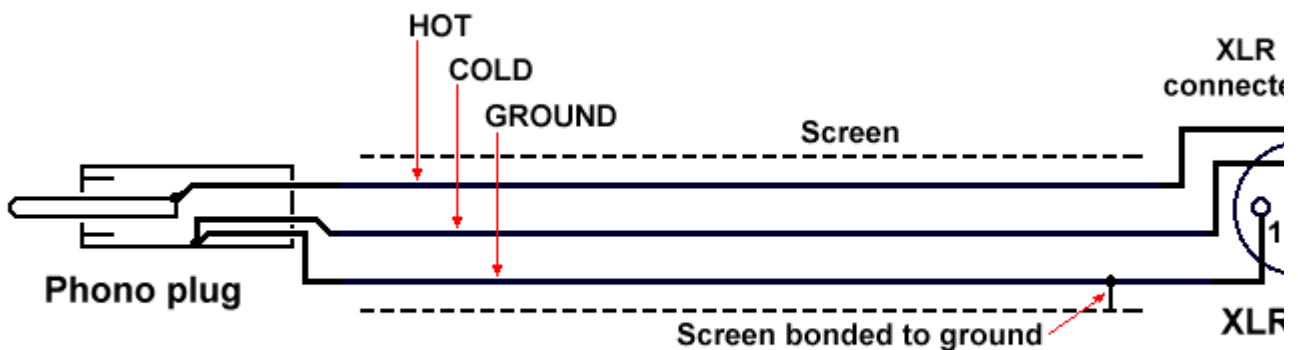

Fig 15 above shows a typical unbalanced to balanced cable. The important point is that the Cold line is connected to ground at the remote (phono) end, and not at the XLR. Thus the balanced inputs at Pins 2 and 3 see only the voltage at the phono plug itself, and any spurious voltages that may exist on the ground line are ignored.

The XLR body, if metal, will have a separate solder tag for making connections to it. It also makes an electrical connection to its mating connector; if this is chassis-mounting then it will usually be grounded so the XLR body tag need not be used. In fact, it is important not to join the body to either ground or Cold as this creates an unwanted connection between audio ground and chassis ground, which may affect system performance.

Case 3) Impedance-balance output TO unbalanced input.

There is nothing to connect the output cold terminal to at the input end, and so this is the same as the ordinary unbalanced connection at 1) above.

Case 4) Impedance-balance output TO balanced input.

In theory there is complete cancellation of both capacitive crosstalk and CM ground voltages, as the line impedances are now exactly equal.

The table below shows the improvement that impedance- balancing offers over a conventional unbalanced output, when driving a balanced input with exactly matched resistors.

Capacitive 1mA	CMRR Conventional	-20 dBv	-46 dB	Impedance-bal 99R	-60 dBv	-101dB
100R	Infinite	-85 dB	Impedance-bal 101R	-60 dBv	-79 dB	

The effect of tolerances in the impedance-balance resistor are also shown; the rejection of capacitive crosstalk degrades as soon as the value moves away from the theoretical 100 Ohms, but the CMRR actually has its point of perfect cancellation slightly displaced to about 98.5 Ohms, due to second-order effects. This is of no consequence in practice.

Case 5) Ground-cancelling output TO unbalanced input.

There is complete cancellation of ground voltages, assuming the ground-cancel output has an accurate unity gain between its cold and hot terminals. (Which is a matter for the manufacturer) This is a very efficient and cost-effective method of interconnection for all levels of equipment, but tends to be more common at the budget end of the market.

Case 6) Ground-cancelling output TO balanced input.

This combination needs a little thought. At first there appears to be a danger that the ground-noise voltage might be subtracted twice, which will of course be equivalent to putting it back in in anti-phase, gaining us nothing. In fact this is not the case, though the cancellation accuracy is compromised compared with the impedance-balanced case; the CM rejection will not exceed 46 dB, even with perfect resistor matching throughout. Capacitive crosstalk is no better than for the "Unbalanced output TO balanced input" ie approx -21 dB, which means virtually no rejection; however this is rarely a problem in practice.

Case 7) Balanced output TO unbalanced input.

This is not a balanced interconnection. There is nowhere to connect the balanced cold output to; it must be left open-circuit, its signal unused, so there is a 6dB loss of headroom in the link. The unbalanced input means the connection is unbalanced, and so there is no noise rejection.

Case 8) Balanced output TO balanced input.

A standard balanced system, that should give good rejection of ground noise and electrostatic crosstalk.

Case 9) Quasi-floating output TO unbalanced input.

Since the input is unbalanced, it is necessary to ground the cold side of the quasi-floating output. If this is done at the remote (input) end then the ground voltage drop is transferred to the hot output by the quasi-floating action, and the ground noise is cancelled in much the same way as a ground-cancelling output.

However, in some cases this ground connection must be local, ie at the output end of the cable, if doing it at the remote (input) end causes HF instability in the quasi-floating output stage. This may happen with very long cables. Such local grounding rules out rejection of ground noise because there is no sensing of the ground voltage drop.

Perhaps the major disadvantage of quasi-floating outputs is the confusion they can cause. Even experienced engineers are liable to mistake them for balanced outputs, and so leave the cold terminal unconnected. This is not a good idea. Even if there are no problems with pickup of external interference on the unterminated cold output, this will cause a serious increase in internal noise. I believe it should be standard practice for such outputs to be clearly marked as what they are.

Case 10) Quasi-floating output TO balanced input.

A standard balanced system, that should give good rejection of ground noise and electrostatic crosstalk.

The hot and cold output impedances are equal, and dominate the line impedance, so even if the line input impedances are unbalanced, there should also be good rejection of electrostatic crosstalk.

[Section 5](#) | [Contents](#) | [Diagram List](#)

7: GROUNDING PHILOSOPHIES.

It has been assumed above that the ground wire is connected at both ends. This can cause various difficulties due to ground currents flowing through it.

For this reason some sound installations have relied on breaking the ground continuity at one end of each cable. This is called the One-End-Only (OEO) rule. [8] It prevents ground currents flowing but usually leaves the system much more susceptible to RF demodulation, as the cable screen is floating at one end, and is now effectively a long antenna for ambient RF. There is also the difficulty that non-standard cables are required, and a consistent rule as to which end of the cable has no ground connection must be enforced. The OEO approach may be workable for a fixed installation that is rarely modified, but for touring sound reinforcement applications it is unworkable.

A compromise that has been found acceptable in some fixed installations is the use of 10nF capacitors to ground the open screen end at RF only; however, the other problems remain. The formal OEO approach must not be confused with "lifting the ground" to cure a ground loop. Unbalanced equipment sometimes provides a ground-lift switch that separates audio signal ground from chassis safety ground; while this can sometimes be effective, it is not as satisfactory as balanced connections. Lifting the ground must NEVER be done by removing the chassis safety earth; this removes all protection against a live conductor contacting the case and so creates a serious hazard. It is also in many cases illegal.

The best approach therefore appears to be grounding at both ends of the cable, and relying on the CMRR of the balanced connection to render ground currents innocuous. Ground currents of 100 mA appear to be fairly common; ground currents measured in amps have however been encountered in systems with serious errors. A typical example is connecting incoming mains "Earth"- which is actually Neutral in many cases- to a technical ground such as a buried copper rod. (See the section "Electrical Noise" in Part 1 of this article for more details)

Ground currents cause the worst problems when they flow not only through cable shields but also the internal signal wiring of equipment. For this reason the preferred practice is to terminate incoming ground wires to the chassis earth of the equipment. This keeps ground currents off PCBs, where the relatively high track resistances would cause bad common- impedance coupling, and preserves RF screening integrity.

Grounding is simplified for source equipment that has no other connections, such as double-insulated CD players and so on. These carry a "square-in-a-square" symbol to denote higher standards of mains insulation, so that external metalwork need not be grounded for safety. Such equipment often has unbalanced outputs, and can usually be connected directly to an unbalanced input with good results, as there is no path for any ground currents to circulate in.

If a balanced input is used, then connecting the hot input to CD signal and the cold to CD "ground" leaves the CD player ground floating, and this will seriously degrade hum and RF rejection. The real ground must be linked to CD player common.

Balanced line interconnections are rather more complex than is immediately obvious. Having said that, with a little caution they work very well indeed.

DIAGRAMS.	
Fig 1	Electrostatic coupling into a signal cable. R_s is 100 Ohms and R is 10k. The second R_s to ground in the cold output line makes it an impedance balanced output.
Fig 2	Magnetic coupling into a signal cable, represented by notional voltage-sources V_m .
Fig 3	Ground-voltages coupling into a signal cable. The ground voltage between A and B is due to ground currents flowing around ABCD
Fig 4a	An unbalanced line output. The cold output (if it exists at all) is connected directly to ground.

Fig 4b	An impedance balanced output. The cold output is connected to ground through a second R_s of identical value.
Fig 5a	A ground-cancelling output, with a unity-gain path from the cold terminal to the hot output. Once more a second R_s balances the line impedances.
Fig 5b	A balanced output. A2 is a unity-gain inverter driving the cold output. Line impedances are balanced.
Fig 6	Simplified diagram of a quasi-floating balanced output, with its essential trim control for output symmetry.
Fig 7	A variable-gain series-feedback unbalanced input stage. R_2 sets mid-position gain.
Fig 8	A shunt-feedback configuration, with a low and variable input impedance.
Fig 9	The standard one-opamp differential amplifier, arranged for unity gain.
Fig 10	A switched-gain balanced input amplifier. The values shown give gains of -6 dB and +6.2 dB, for switching between pro and semi-pro interface levels.
Fig 11	A variable-gain balanced input amplifier. Gain range is -10 to +20 dB. R_6 sets the mid-position gain.
Fig 12	The "Superbal" balanced input stage; input impedance on hot and cold are equal for both differential and common mode.
Fig 13	A hi-Z balanced input stage; R_5 and R_6 set input impedance, and can be much higher. Add R_g to increase gain.
Fig 14	Balanced attenuators to convert a microphone preamp to line input. 14b is superior as both differential and CM signals are equally attenuated, so CMRR is not degraded more than necessary.
Fig 15	A typical unbalanced to balanced cable. (Phono to XLR)

REFERENCES.	
1] Williams, T	"EMC for Product Designers." Newnes (Butterworth-Heinemann) pub 1992 ISBN 0 7506 1264 9 p176
2] Williams, T	As [1] above, p173.
3] Muncy, N	"Noise Susceptibility in Analog and Digital Signal Processing Systems." JAES Vol3 #6, June 1995, p447
4] Muncy, N	As [3] above, p441
5] Winder,S	"What's The Difference?" Electronics World, Nov 1995, p989.
6] Ballou G (ed)	"Handbook For Sound Engineers- The Audio Cyclopaedia" Howard Sams 1987. ISBN 0-672-21983-2 (Superbal)

7] Smith J L	"Modern Operational Circuit Design" Wiley-Interscience, 1971, p31,241.
8] Muncy, N	"Noise Susceptibility in Analog and Digital Signal Processing Systems." JAES Vol3 #6, June 1995, p440

[Home](#) [Contents](#) [Back](#)

