

UL 6500

ISBN 0-7629-0412-7

Audio/Video and Musical  
Instrument Apparatus  
for Household, Commercial,  
and Similar General Use



Underwriters Laboratories Inc. (UL)  
333 Pfingsten Road  
Northbrook, IL 60062-2096

UL Standard for Safety for Audio/Video and Musical Instrument Apparatus for Household, Commercial, and Similar General Use, UL 6500

Second Edition, Dated September 30, 1999

Revisions: This Standard contains revisions through and including June 23, 2000.

The new and/or revised requirements are substantially in accordance with UL's Bulletin(s) on this subject dated February 14, 2000. The bulletin(s) is now obsolete and may be discarded.

UL is in the process of converting its Standards for Safety to the Standard Generalized Markup Language (SGML), and implementing an SGML compliant document management and publishing system. SGML - an international standard (ISO 8879-1986) - is a descriptive markup language that describes a document's structure and purpose, rather than its physical appearance on a page. Significant benefits that will result from UL's use of SGML and these new systems include increased productivity, reduced turnaround times, and data and information consistency, reusability, shareability, and portability. However, the fonts, pagination, and general formatting of UL's new electronic publishing system differ from that of UL's previous publishing system. Consequently, when revision pages are issued for a Standard with the new publishing system, these differences may result in the printing of pages on which no requirements have been changed - these additional pages result from relocation of text due to repagination and reformatting of the Standard with the new publishing system.

Text that has been changed in any manner is marked with a vertical line in the margin. Changes in requirements are marked with a vertical line in the margin and are followed by an effective date note indicating the date of publication or the date on which the changed requirement becomes effective.

The following table lists the future effective dates with the corresponding item.

Future Effective Dates	References
January 31, 2003	19, 19.1, 19.2.1, 19.2.2, R.21.1 Tables R1, R1A, R1B

The revisions dated June 23, 2000 include a reprinted title page (page1) for this Standard.

The master for this Standard at UL's Northbrook Office is the official document insofar as it relates to a UL service and the compliance of a product with respect to the requirements for that product and service, or if there are questions regarding the accuracy of this Standard.

UL's Standards for Safety are copyrighted by UL. Neither a printed copy of a Standard, nor the distribution diskette for a Standard-on-Diskette and the file for the Standard on the distribution diskette should be altered in any way. All of UL's Standards and all copyrights, ownerships, and rights regarding those Standards shall remain the sole and exclusive property of UL.

All rights reserved. No part of this publication may be reproduced, stored in a retrieval system, or transmitted in any form by any means, electronic, mechanical photocopying, recording, or otherwise without prior permission of UL.

Revisions of UL Standards for Safety are issued from time to time. A UL Standard for Safety is current only if it incorporates the most recently adopted revisions.

UL provides this Standard "as is" without warranty of any kind, either expressed or implied, including but not limited to, the implied warranties of merchantability or fitness for any purpose.

In no event will UL be liable for any special, incidental, consequential, indirect or similar damages, including loss of profits, lost savings, loss of data, or any other damages arising out of the use of or the inability to use this Standard, even if UL or an authorized UL representative has been advised of the possibility of such damage. In no event shall UL's liability for any damage ever exceed the price paid for this Standard, regardless of the form of the claim.

UL will attempt to answer support requests concerning electronic versions of its Standards. However, this support service is offered on a reasonable efforts basis only, and UL may not be able to resolve every support request. UL supports the electronic versions of its Standards only if they are used under the conditions and operating systems for which it is intended. UL's support policies may change from time-to-time without notification.

UL reserves the right to change the format, presentation, file types and formats, delivery methods and formats, and the like of both its printed and electronic Standards without prior notice.

Purchasers of the electronic versions of UL's Standards for Safety agree to defend, indemnify, and hold UL harmless from and against any loss, expense, liability, damage, claim, or judgement (including reasonable attorney's fees) resulting from any error or deviation introduced while purchaser is storing an electronic Standard on the purchaser's computer system.

If a single-user version electronic Standard was purchased, one copy of this Standard may be stored on the hard disk of a single personal computer, or on a single LAN file-server or the permanent storage device of a multiple-user computer in such a manner that this Standard may only be accessed by one user at a time and for which there is no possibility of multiple concurrent access.

If a multiple-user version electronic Standard was purchased, one copy of the Standard may be stored on a single LAN file-server, or on the permanent storage device of a multiple-user computer, or on an Intranet server. The number of concurrent users shall not exceed the number of users authorized.

Electronic Standards are intended for on-line use, such as for viewing the requirements of a Standard, conducting a word search, and the like. Only one copy of the Standard may be printed from each single-user version of an electronic Standard. Only one copy of the Standard may be printed for each authorized user of a multiple-user version of an electronic Standard. Because of differences in the computer/software/printer setup used by UL and those of electronic Standards purchasers, the printed copy obtained by a purchaser may not look exactly like the on-line screen view or the printed Standard.

An employee of an organization purchasing a UL Standard can make a copy of the page or pages being viewed for their own fair and/or practical internal use.

The requirements in this Standard are now in effect, except for those paragraphs, sections, tables, figures, and/or other elements of the Standard having future effective dates as indicated in the note following the affected item. The prior text for requirements that have been revised and that have a future effective date are located after the Standard, and are preceded by a "SUPERSEDED REQUIREMENTS" notice.

New product submittals made prior to a specified future effective date will be judged under all of the requirements in this Standard including those requirements with a specified future effective date, unless the applicant specifically requests that the product be judged under the current requirements. However, if

the applicant elects this option, it should be noted that compliance with all the requirements in this Standard will be required as a condition of continued Listing, Recognition and Follow-Up Services after the effective date, and understanding of this should be signified in writing.

Copyright © 2000 Underwriters Laboratories Inc.

This Standard consists of pages dated as shown in the following checklist:

Page	Date
1-4B	June 23, 2000
5-16	September 30, 1999
17-18B	June 23, 2000
19	September 30, 1999
20-20B	June 23, 2000
21-24	September 30, 1999
25	June 23, 2000
26-38	September 30, 1999
39-40B	June 23, 2000
41-54	September 30, 1999
55-56B	June 23, 2000
57-62	September 30, 1999
63-64B	June 23, 2000
65-72	September 30, 1999
73-74B	June 23, 2000
75	September 30, 1999
76-79	June 23, 2000
80	September 30, 1999
81-82B	June 23, 2000
83-88	September 30, 1999
89-90	June 23, 2000
91-109	September 30, 1999
110	June 23, 2000
111-117	September 30, 1999
118-118B	June 23, 2000
119-120	September 30, 1999
121-123	June 23, 2000
124-132	September 30, 1999
133	June 23, 2000
134-140	September 30, 1999
141	June 23, 2000
142	September 30, 1999
A1-A2	September 30, 1999
B1-B4	September 30, 1999
C1-C2	September 30, 1999
D1-D2	September 30, 1999
E1-E6	September 30, 1999
F1-F2	September 30, 1999
G1-G4	September 30, 1999
H1-H8	September 30, 1999
I1-I4	September 30, 1999
J1-J2	September 30, 1999
K1-K6	September 30, 1999
L1-L4	September 30, 1999
M1-M4	September 30, 1999
N1-N4	September 30, 1999
O1-O2	September 30, 1999
P1-P2	September 30, 1999
Q1-Q2	September 30, 1999

---

R1-R2 .....	June 23, 2000
R3-R6 .....	September 30, 1999
S1-S2 .....	June 23, 2000
SR1-SR4.....	June 23, 2000

No Text on This Page



**SEPTEMBER 30, 1999**  
(Title Page Reprinted: June 23, 2000)

1

**UL 6500**

**Standard for Audio/Video and Musical Instrument Apparatus for  
Household, Commercial, and Similar General Use**

First Edition – May, 1996

**Second Edition**

**September 30, 1999**

An effective date included as a note immediately following certain requirements is one established by Underwriters Laboratories Inc.

Revisions of this Standard will be made by issuing revised or additional pages bearing their date of issue. A UL Standard is current only if it incorporates the most recently adopted revisions, all of which are itemized on the transmittal notice that accompanies the latest set of revised requirements.

**ISBN 0-7629-0412-7**

**COPYRIGHT © 1996, 2000 UNDERWRITERS LABORATORIES INC.**

No Text on This Page

**CONTENTS**

<b>UL PREFACE</b> .....	7
<b>Foreword (UL)</b> .....	8
<b>DEVIATIONS</b> .....	9
<b>FOREWORD</b> .....	10
<b>INTRODUCTION</b> .....	12
1 General .....	15
1.1 Scope .....	15
1.2 Normative references .....	17
2 Definitions .....	21
2.1 Definitions in alphabetical order .....	21
2.2 Types of apparatus .....	22
2.3 Ratings and electrical values .....	23
2.4 Supply and external connections .....	24
2.5 Signals, sources, loads .....	25
2.6 Protection against electric shock, insulations .....	26
2.7 Components .....	27
2.8 Miscellaneous .....	28
3 General requirements .....	30
4 General test conditions .....	30
4.1 Conduct of tests .....	30
4.2 Normal operating conditions .....	32
4.3 Fault conditions .....	34
5 Markings and instructions .....	37
5.1 Identification and supply ratings .....	38
5.2 TERMINALS .....	39
5.4 Instructions .....	40A
6 Hazardous radiations .....	42
6.1 Ionizing radiation .....	42
6.2 Laser radiation .....	43
7 Heating under normal operating conditions .....	45
7.1 General .....	45
7.2 Heat resistance of insulating material .....	48
8 Constructional requirements with regard to the protection against electric shock .....	49
9 Electric shock hazard under normal operating conditions .....	55
9.1 Testing on the outside .....	55
9.2 Removal of protective covers .....	59
10 Insulation requirements .....	59
10.1 Surge test .....	59
10.2 Humidity treatment .....	59
10.3 Insulation resistance and dielectric strength .....	60
11 Fault conditions .....	63
11.1 Electric shock hazard .....	63
11.2 Heating .....	64
12 Mechanical strength .....	67
12.1 Complete apparatus .....	67

12.2	Fixing of actuating elements .....	70
12.3	REMOTE CONTROL devices held in hand .....	71
12.4	Drawers .....	71
12.5	Antenna coaxial sockets mounted on the apparatus .....	71
12.6	<u>Telescoping or rod antenna</u> .....	72
12.7	<u>Wall or ceiling mounting means</u> .....	73
13	CLEARANCES and CREEPAGE DISTANCES .....	73
13.1	General .....	74
13.2	CLEARANCES and CREEPAGE DISTANCES: dimensions .....	75
14	Components .....	77
14.1	Resistors .....	78
14.2	Capacitors and RC-units .....	79
14.3	Inductors and windings .....	81
14.4	High voltage components and assemblies .....	84
14.5	Protective devices .....	87
14.6	Switches .....	92
14.7	SAFETY INTERLOCKS .....	98
14.8	Voltage setting devices and the like .....	98
14.9	Motors .....	98
14.10	Batteries .....	99
14.11	Optocouplers .....	100
15	TERMINALS .....	100
15.1	Plugs and sockets .....	100
15.2	Provisions for protective earthing .....	102
15.3	TERMINALS for external flexible cords and for permanent connection to the MAINS supply ..	104
15.4	Devices forming a part of the MAINS plug .....	107
16	External flexible cords .....	108
17	Electrical connections and mechanical fixings .....	112
18	Mechanical strength of picture tubes and protection against the effects of implosion .....	115
18.2	Intrinsically protected picture tubes, including those having integral protective screens .....	116
18.3	Non-intrinsically protected picture tubes .....	117
19	Stability and mechanical hazards .....	118
19.4.1	Fragmentation test .....	119
19.5	Rack mounting test .....	119
20	Resistance to fire .....	119
20.1	Electrical components and mechanical parts .....	120
20.2	Fire enclosure .....	123

**Annex A (normative) Additional requirements for apparatus with ~~protection against splashing water for outdoor use and wet locations~~**

A.5	Marking and instructions <sup>1)</sup> .....	A1
A.9.1.1	General .....	A1
A.10	Insulation requirements .....	A2

**Annex B (normative) Apparatus to be connected to the TELECOMMUNICATION NETWORKS**

B.2 Definitions <sup>1)</sup> .....	.B1
B.5 Marking and instructions .....	.B1
B.8 Constructional requirements with regard to protection against electric shock .....	.B2
B.9 Electric shock hazard under normal operating conditions .....	.B2

No Text on This Page

B.10 Insulation requirements .....B3  
 B.14 Components .....B3

**Annex C (normative) Band-pass filter for wide-band noise measurement (Extract of IEC 60268-1)**

**Annex D (normative) Measuring network for TOUCH CURRENTS**

**Annex E (normative) Measurement of CLEARANCES and CREEPAGE DISTANCES**

**Annex F (normative) Table of electrochemical potentials**

**Annex G — DC (normative) Flammability test methods**

**Annex H DU (normative) Safety requirements for video apparatus for use in health care facilities**

**Annex I DU (normative) Safety requirements for undercabinet apparatus**

**Annex J DU (normative) Safety requirements for in-wall mounted apparatus**

**Annex K DU (normative) Safety requirements for apparatus with projection lamps**

**Annex L DU (normative) Safety requirements for permanently connected apparatus**

**Annex M DU (normative) Safety requirements for carts, stands, and similar apparatus for use with specific apparatus covered by this standard**

M.19 Mechanical stability .....M3

**Annex N (informative) ROUTINE TEST**

N.1 Tests during the production process .....N1  
 N.2 Tests at the end of the production process .....N2

**Annex O DE Reserved for future use**

**Annex P (informative) Bibliography**

**Annex Q DU (informative) A 0.02-ohm shunt for use in the peak inrush-current measurement described in 14.6.11.1**

**Annex R DU (normative) Manufacturing and production-line tests and verifications**

**Annex S DC (normative) Standards for components**



## UL PREFACE

This UL Standard is based on IEC Publication 60065: sixth edition, Safety of Audio, video and similar electronic apparatus – Safety Requirements. IEC publication 60065 is copyrighted by the IEC.

The text, figures and tables of IEC Publication Safety of Audio, video and similar electronic apparatus – Safety Requirements, 60065, copyright 1998, are used in this Standard with the consent of the IEC and the American National Standards Institute (ANSI). The IEC copyrighted material has been reproduced with permission from ANSI. ANSI should be contacted regarding the reproduction of any portion of the IEC material. The IEC Foreword and Introduction are not part of the requirements of the Standard but are included for information purposes only. Copies of IEC Publication 60065 may be purchased from ANSI, 11 West 42nd Street, New York, New York, 10036, (212) 642-4900.

**Note – Although the intended primary application of this Standard is stated in its Scope, it is important to note that it remains the responsibility of the users of the Standard to judge its suitability for their particular purpose.**

## Foreword (UL)

A. This Standard contains basic requirements for products covered by Underwriters Laboratories Inc. (UL) under its Follow-Up Service for this category within the limitations given below and in the Scope section of this Standard. These requirements are based upon sound engineering principles, research, records of tests and field experience, and an appreciation of the problems of manufacture, installation, and use derived from consultation with and information obtained from manufacturers, users, inspection authorities, and others having specialized experience. They are subject to revision as further experience and investigation may show is necessary or desirable.

B. The observance of the requirements of this Standard by a manufacturer is one of the conditions of the continued coverage of the manufacturer's product.

C. A product which complies with the text of this Standard will not necessarily be judged to comply with the Standard if, when examined and tested, it is found to have other features which impair the level of safety contemplated by these requirements.

D. A product employing materials or having forms of construction which conflict with specific requirements of the Standard cannot be judged to comply with the Standard. A product employing materials or having forms of construction not addressed by this Standard may be examined and tested according to the intent of the requirements and, if found to meet the intent of this Standard, may be judged to comply with the Standard.

E. UL, in performing its functions in accordance with its objectives, does not assume or undertake to discharge any responsibility of the manufacturer or any other party. The opinions and findings of UL represent its professional judgment given with due consideration to the necessary limitations of practical operation and state of the art at the time the Standard is processed. UL shall not be responsible to anyone for the use of or reliance upon this Standard by anyone. UL shall not incur any obligation or liability for damages, including consequential damages, arising out of or in connection with the use, interpretation of, or reliance upon this Standard.

F. Many tests required by the Standards of UL are inherently hazardous and adequate safeguards for personnel and property shall be employed in conducting such tests.

## DEVIATIONS

### GENERAL

Deviations from the text of International Electrotechnical Commission (IEC) Publication 60065, Audio, video and similar electronic apparatus – Safety Requirements, copyright 1998 are indicated by notations next to the clause, sub-clause, Table, Figure or Annex number.

There are basically four types of deviations:

**DR – Deviations based on the National Electrical Code (NEC) and other U.S. Regulatory Requirements.**

**DU – Deviations based on Basic Safety Principles and safety practices:** These are deviations which are either 1) based on basic safety principles and requirements, elimination of which would compromise safety for U.S. consumers, or 2) deviations for IEC requirements that may be acceptable, but adopting the IEC requirements would require considerable retesting or redesign on the manufacturer's part.

**DC – Deviations based on component standards:** These are deviations based on the component standards and will not be deleted until a particular component standard is harmonized with the IEC component standard.

**DE – Deviations based on absolute statements or editorial corrections.**

Deviations have been incorporated into the body of the standard. If deviations necessitate the deletion of the IEC 60065 text, the IEC 60065 text has been retained but has been ~~lined-out~~. Text added as a result of deviations has been underlined. Text added as the UL Preface and UL Foreword is not underlined.

## INTERNATIONAL ELECTROTECHNICAL COMMISSION

---

### AUDIO, VIDEO AND SIMILAR ELECTRONIC APPARATUS – SAFETY REQUIREMENTS

## FOREWORD

- 1) The IEC (International Electrotechnical Commission) is a worldwide organization for standardization comprising all national electrotechnical committees (IEC National Committees). The object of the IEC is to promote international co-operation on all questions concerning standardization in the electrical and electronic fields. To this end and in addition to other activities, the IEC publishes International Standards. Their preparation is entrusted to technical committees; any IEC National Committee interested in the subject dealt with may participate in this preparatory work. International, governmental and non-governmental organizations liaising with the IEC also participate in this preparation. The IEC collaborates closely with the International Organization for Standardization (ISO) in accordance with conditions determined by agreement between the two organizations.
- 2) The formal decisions or agreements of the IEC on technical matters express, as nearly as possible, an international consensus of opinion on the relevant subjects since each technical committee has representation from all interested National Committees.
- 3) The documents produced have the form of recommendations for international use and are published in the form of standards, technical reports or guides and they are accepted by the National Committees in that sense.
- 4) In order to promote international unification, IEC National Committees undertake to apply IEC International Standards transparently to the maximum extent possible in their national and regional standards. Any divergence between the IEC Standard and the corresponding national or regional standard shall be clearly indicated in the latter.
- 5) The IEC provides no marking procedure to indicate its approval and cannot be rendered responsible for any equipment declared to be in conformity with one of its standards.
- 6) Attention is drawn to the possibility that some of the elements of this International Standard may be the subject of patent rights. The IEC shall not be held responsible for identifying any or all such patent rights.

International Standard IEC 60065 has been prepared by IEC technical committee 92: Safety of audio, video and similar electronic equipment.

This sixth edition cancels and replaces the fifth edition published in 1985, its amendments 1 (1987), 2 (1989) and 3 (1992). This edition constitutes a technical revision.

It has the status of a group safety publication in accordance with IEC Guide 104.

The text of this standard is based on the following documents:

FDIS	Report on voting
92/60/FDIS	92/61/RVD

Full information on the voting for the approval of this standard can be found in the report on voting indicated in the above table.

In this standard, the following print types are used

- requirements proper: roman type
- *test specifications: italic type*
- NOTES: smaller roman type

For terms defined in clause 2, SMALL CAPITALS are used.

Annexes A, B, C, D, E, F and G form an integral part of this standard.

Annexes N and P are for information only.

# INTRODUCTION

## Principles of safety

### *General*

This introduction is intended to provide an appreciation of the principles on which the requirements of this standard are based. Such an understanding is essential in order that safe apparatus can be designed and manufactured.

The requirements of this standard are intended to provide protection to persons as well as to the surroundings of the apparatus.

Attention is drawn to the principle that the requirements, which are standardized, are the minimum considered necessary to establish a satisfactory level of safety.

Further development in techniques and technologies may entail the need for future modification of this standard.

NOTE – The expression “protection to the surroundings of the apparatus” implies that this protection should also include protection of the natural environment in which the apparatus is intended to be used, taking into account the life cycle of the apparatus, i.e. manufacturing, use, maintenance, disposal and possible end-of-life recycling of parts of the apparatus.

### *Hazards*

The application of this standard is intended to prevent injury or damage due to the following hazards:

- electric shock;
- excessive temperatures;
- radiation;
- implosion;
- mechanical hazards;
- fire.

### *Electric shock*

Electric shock is due to current passing through the human body. Currents of the order of a milliampere can cause a reaction in persons in good health and may cause secondary risks due to involuntary reaction. Higher currents can have more damaging effects. Voltages below certain limits are generally regarded as not dangerous under specified conditions. In order to provide protection against the possibility of higher voltages appearing on parts which may be touched or handled, such parts are either earthed or adequately insulated.

For parts which can be touched, two levels of protection are normally provided to prevent electric shock caused by a fault. Thus a single fault and any consequential faults will not create a hazard. The provision of additional protective measures, such as supplementary insulation or protective earthing, is not

considered a substitute for, or a relief from, properly designed basic insulation.

Cause	Prevention
Contact with parts normally at hazardous voltage	Prevent access to parts at hazardous voltage by fixed or locked covers, interlocks, etc. Discharge capacitors at hazardous voltages.
Breakdown of insulation between parts normally at hazardous voltage and accessible parts.	Either use double or reinforced insulation between parts normally at hazardous voltages and accessible parts so that breakdown is not likely to occur, or connect accessible conductive parts to protective earth so that the voltage which can develop is limited to a safe value. The insulations shall have adequate mechanical and electrical strength.
Breakdown of insulation between parts normally at hazardous voltage and circuits normally at non-hazardous voltages, thereby putting accessible parts and terminals at hazardous voltage.	Segregate hazardous and non-hazardous voltage circuits either by double or reinforced insulation so that breakdown is not likely to occur, or by a protective earthed screen, or connect the circuit normally at non-hazardous voltage to protective earth, so that the voltage which can develop is limited to a safe value.
Touch current from parts at hazardous voltage through the human body. (Touch current can include current due to RFI filter components connected between mains supply circuits and accessible parts or terminals.)	Limit touch current to a safe value or provide protective earth connection to the accessible parts.

### *Excessive temperatures*

Requirements are included to prevent injury due to excessive temperatures of accessible parts, to prevent damaging of insulation due to excessive internal temperatures, and to prevent mechanical instability due to excessive temperatures developed inside the apparatus.

### *Radiation*

Requirements are included to prevent injury due to excessive energy levels of ionizing and laser radiation, for example by limiting the radiation to non-hazardous values.

### *Implosion*

Requirements are included to prevent injury due to implosion of picture tubes.

### *Mechanical hazards*

Requirements are included to ensure that the apparatus and its parts have adequate mechanical strength and stability, to avoid the presence of sharp edges and to provide guarding or interlocking of dangerous moving parts.

### *Fire*

A fire can result from:

- overloads;
- component failure;

- insulation breakdown;
- bad connections;
- arcing.

Requirements are included to prevent any fire which originates within the apparatus from spreading beyond the immediate vicinity of the source of the fire or from causing damage to the surroundings of the apparatus.

The following preventive measures are recommended:

- the use of suitable components and sub-assemblies;
- the avoidance of excessive temperatures which might cause ignition under normal or fault conditions;
- the use of measures to eliminate potential ignition sources such as inadequate contacts, bad connections, interruptions;
- the limitation of the quantity of combustible material used;
- the control of the position of combustible materials in relation to potential ignition sources;
- the use of materials with high resistance to fire in the vicinity of potential ignition sources;
- the use of encapsulation or barriers to limit the spread of fire within the apparatus;
- the use of suitable fire retardant materials for the enclosure.



# AUDIO, VIDEO AND SIMILAR ELECTRONIC APPARATUS – SAFETY REQUIREMENTS

## 1 General

### 1.1 Scope

**1.1.1 DU** This International Standard applies to electronic apparatus designed to be fed from the MAINS or from a SUPPLY APPARATUS and intended for reception, generation, recording or reproduction respectively of audio, video and associated signals. It also applies to apparatus designed to be used exclusively in combination with the above mentioned apparatus. This standard concerns only safety aspects of the above apparatus; it does not concern other matters, such as style or performance.

For above-mentioned apparatus, which are fed from a supply source other than the MAINS or from a SUPPLY APPARATUS, and which contain a LASER SYSTEM or produce an internal OPERATING VOLTAGE greater than 4000 V (peak), this standard applies as far as applicable.

NOTE 1 – In Australia, Canada, Denmark, Japan, Rumania, South Africa, United States of America and United Kingdom this standard is, where relevant, used as a guide for the testing of battery operated apparatus.

This standard applies to the above-mentioned apparatus, if it is designed to be connected to the TELECOMMUNICATION NETWORK or similar network, for example by means of an integrated modem.

Some examples of apparatus within the scope of this standard are:

- receiving apparatus and amplifiers for sound and/or vision;
- independent LOAD TRANSDUCERS and SOURCE TRANSDUCERS;
- SUPPLY APPARATUS intended to supply other apparatus covered by the scope of this standard;
- ELECTRONIC MUSICAL INSTRUMENTS, and electronic accessories such as rhythm generators, tone generators, music tuners and the like for use with electronic or non-electronic musical instruments;
- audio and/or video educational apparatus;
- video projectors;
- video cameras and video monitors;
- household video games and flipper games;

NOTE 2 – Video and flipper games for commercial use are covered by IEC 60335-2-82 [7] UL 22

- juke boxes;

\*Figures in square brackets refer to the bibliography given in annex P.

- household electronic gaming and scoring machines;

NOTE 3 – Electronic gaming and scoring machines for commercial use are covered by IEC 60335-2-82 [7] UL 22

- teletext equipment;
- record and optical disc players;
- tape and optical disc recorders;
- antenna signal converters and amplifiers;
- satellite receiver antenna positioners;
- Citizen's Band apparatus;
- apparatus for IMAGERY;
- light effect apparatus;
- intercommunication apparatus, using low voltage MAINS as the transmission medium.
- video apparatus intended for entertainment purposes in health-care facilities;
- cellular phones, wireless modems, and similar transceiving devices;
- audio or video apparatus that are used with a battery supply.

MAINS connected apparatus covered by this standard is intended for installation in compliance with the National Electrical Code, ANSI/NFPA 70.

Any undated reference to a code or a standard appearing in the requirements of this standard shall be interpreted as referring to the latest edition of that code or standard.

**1.1.2** This standard applies to apparatus with a RATED SUPPLY VOLTAGE not exceeding:

- 250 V a.c. single phase or d.c. supply,
- 433 V a.c. in the case of apparatus for connection to a supply other than single phase.

**1.1.3 DU** This standard applies to apparatus for use at altitudes not exceeding 2000 m above sea level, primarily in dry locations and in regions with moderate or tropical climates.

For apparatus with ~~protection against splashing water~~ intended for outdoor use, additional requirements are given in annex A.

For apparatus to be connected to TELECOMMUNICATION NETWORKS, additional requirements are given in annex B.

For apparatus intended to be used in vehicles, ships or aircraft, or at altitudes exceeding 2000 m above sea level, additional requirements may be necessary.

Requirements, additional to those specified in this standard, may be necessary for apparatus intended for special conditions of use.

**1.1.4** For apparatus designed to be fed from the MAINS, this standard applies to apparatus intended to be connected to a MAINS supply with transient overvoltages not exceeding overvoltage category II according to IEC 60664-1.

For apparatus subject to transient overvoltages exceeding those for overvoltage category II, additional protection may be necessary in the MAINS supply of the apparatus.

**1.1.5** This standard does not apply to the following apparatus, except where this standard is referenced in the relevant standard:

- apparatus falling within the scope of IEC 60950,
- dictation apparatus,
- projectors not mentioned in 1.1.1, for example film projectors, slide projectors, overhead projectors, epidiascopes. (See IEC 60335-2-56 [6].)

**1.1.6 DU** Certain apparatus covered by the requirements in this standard are also required to comply with applicable requirements in other appropriate standards because of their intended end use applications or environmental conditions.

An apparatus that contains features, characteristics, components, materials, or systems new or different from those covered by the requirements in this standard, that involves a risk of fire or of electric shock or injury to persons shall be evaluated using appropriate additional component and end-product requirements to maintain the level of safety as originally anticipated by the intent of this standard. An apparatus whose features, characteristics, components, materials, or systems conflict with specific requirements or provisions of this standard does not comply with this standard. Revision of requirements shall be proposed and adopted in conformance with the methods employed for development, revision, and implementation of this standard.

1.1.6 revised June 23, 2000

## 1.2 DC Normative references

1.2 revised June 23, 2000

The following normative documents contain provisions which, through reference in this text, constitute provisions of this International Standard. At the time of publication, the editions indicated were valid. All normative documents are subject to revision, and parties to agreements based on this International

Standard are encouraged to investigate the possibility of applying the most recent editions of the normative documents indicated below. Members of IEC and ISO maintain registers of currently valid International Standards.

IEC 60027 (all parts), *Letter symbols to be used in electrical technology*

IEC 60038:1983, *IEC standard voltages*

IEC 60068-2-3:1969, *Environmental testing – Part 2: Tests – Test Ca: Damp heat, steady state*

IEC 60068-2-6:1995, *Environmental testing – Part 2: Tests – Test Fc: Vibration (sinusoidal)*

IEC 60068-2-32:1975, *Environmental testing – Part 2: Tests – Test Ed: Free fall (Procedure 1)*

IEC 60068-2-75:1997, *Environmental testing – Part 2-75: Tests – Test Eh: Hammer tests*

IEC 60085:1984, *Thermal evaluation and classification of electrical insulation*

IEC 60112:1979, *Method for determining the comparative and the proof tracking indices of solid insulating materials under moist conditions*

IEC 60127 (all parts), *Miniature fuses*

IEC 60167:1964, *Methods of test for the determination of the insulation resistance of solid insulating materials*

IEC 60227 (all parts), *Polyvinyl chloride insulated cables of rated voltages up to and including 450/750 V*

~~IEC 60245 (all parts), *Rubber insulated cables – Rated voltages up to and including 450/750 V*~~

IEC 60249-2 (all specifications), *Base materials for printed circuits – Part 2: Specifications*

IEC 60268-1:1985, *Sound system equipment – Part 1: General*

IEC 60317 (all parts), *Specifications for particular types of winding wires*

IEC 60320 (all parts), *Appliance couplers for household and similar general purposes*

IEC 60335-1:1991, *Safety of household and similar electrical appliances – Part 1: General requirements*

IEC 60384-1:1982, *Fixed capacitors for use in electronic equipment – Part 1: Generic specification*

IEC 60384-14:1993, *Fixed capacitors for use in electronic equipment – Part 14: Sectional specification: Fixed capacitors for electromagnetic interference suppression and connection to the supply mains. Amendment 1 (1995)*

IEC 60417 (all parts), *Graphical symbols for use on equipment, Index, survey and compilation of single sheets*

IEC 60454 (all parts), *Specifications for pressure-sensitive adhesive tapes for electrical purposes*

~~IEC 60529:1989, *Degrees of protection provided by enclosures (IP Code)*~~

IEC 60536:1976, *Classification of electrical and electronic equipment with regard to protection against electric shock*

No Text on This Page

- IEC 60664-1:1992, *Insulation coordination for equipment within low-voltage systems – Part 1: Principles, requirements and tests*
- IEC 60664-3:1992, *Insulation coordination for equipment within low-voltage systems – Part 3: Use of coatings to achieve insulation coordination of printed board assemblies*
- ~~IEC 60691:1993, *Thermal-links – Requirements and application guide*~~
- IEC 60695-2-2:1991, *Fire hazard testing – Part 2: Test methods – Section 2: Needle flame test*
- IEC 60707:1981, *Methods of test for the determination of the flammability of solid electrical insulating materials when exposed to an igniting source*
- IEC 60730 (all parts), *Automatic electrical controls for household and similar use*
- ~~IEC 60738 (all parts), *Directly heated positive step-function temperature coefficient thermistors*~~
- ~~IEC 60825-1:1993, *Safety of laser products – Part 1: Equipment classification, requirements and user's guide*~~
- IEC 60884 (all parts), *Plugs and socket-outlets for household and similar purposes*
- IEC 60885-1:1987, *Electrical test methods for electric cables – Part 1: Electrical tests for cables, cords and wires for voltages up to and including 450/750 V*
- IEC 60906 (all parts), *IEC system of plugs and socket-outlets for household and similar purposes*
- IEC 60950:1991, *Safety of information technology equipment*
- ~~IEC 60990:1990, *Methods of measurements of touch-current and protective-conductor-current*~~
- IEC 60998-2-2:1991, *Connecting devices for low voltage circuits for household and similar purposes – Part 2-2: Particular requirements for connecting devices as separate entities with screwless-type clamping units*
- IEC 60999:1990, *Connecting devices – Safety requirements for screw-type and screwless-type clamping units for electrical copper conductors*
- IEC 61032:1990, *Test probes to verify protection by enclosures*
- ~~IEC 61058-1:1996, *Switches for appliances – Part 1: General requirements*~~
- IEC 61149:1995, *Guide for safe handling and operation of mobile radio equipment*
- IEC 61260:1995, *Electroacoustics – Octave-band and fractional-octave-band filters*
- IEC 61293:1994, *Marking of electrical equipment with ratings related to electrical supply – Safety requirements*
- ISO 261:1973, *ISO general purpose metric screw threads – General plan*
- ISO 262:1973, *ISO general purpose metric screw threads – Selected sizes for screws, bolts and nuts*

ISO 306:1994, *Plastics – Thermoplastic materials – Determination of Vicat softening temperature (VST)*

ISO 7000:1989, *Graphical symbols for use on equipment – Index and synopsis*

UL 50, *Enclosures for Electrical Equipment*

UL 94, *Tests for Flammability of Plastic Materials for Parts in Devices and Appliances*

UL 224, *Extruded Insulating Tubing*

UL 248-14, *Low Voltage Fuses – Part 14: Supplemental Fuses*

UL 508, *Industrial Control Equipment*

UL 510, *Polyvinyl Chloride, Polyethylene and Rubber Insulating Tape*

UL 746B, *Polymeric Materials – Long Term Property Evaluations*

UL 746C, *Polymeric Materials – Use in Electrical Equipment Evaluations*

UL 746D, *Polymeric Materials – Fabricated Parts*

UL 796, *Printed Wiring Boards*

UL 817, *Cord Sets and Power-Supply Cords*

UL 873, *Temperature-Indicating and -Regulating Equipment*

UL 1020, *Thermal Cutoffs for Use in Electrical Appliances and Components*

UL 1414, *Across-The-Line, Antenna-Coupling, and Line-By-Pass Capacitors for Radio- and Television-Type Appliances*

UL 1416, *Overcurrent and Overtemperature Protectors for Radio- and Television-Type Appliances*

UL 1417, *Special Fuses for Radio- and Television-Type Appliances*

UL 1418, *Cathode Ray Tubes*

UL 1434, *Thermistor-Type Devices*

UL 1441, *Coated Electrical Sleeving*

UL 1571, *Incandescent Lightning Fixtures*

UL 1577, *Optical Isolators*

UL 1950, Third Edition, *Information Technology Equipment*

UL 2111, *Overheating Protection for Motors*

UL 8730-2-9, *Automatic Electrical Controls for Household and Similar Use; Part 2: Particular Requirements for Temperature Sensing Controls*



UL 61058-1, *Switches for Appliances*

No Text on This Page

## 2 Definitions

For the purpose of this International Standard, the following definitions apply.

### 2.1 DU Definitions in alphabetical order

ACCESSIBLE	2.8.3
<u>ACCESSORY</u>	<u>2.8.13</u>
ALL-POLE MAINS SWITCH	2.7.11
AUDIO AMPLIFIER	2.2.1
AVAILABLE POWER	2.3.7
BASIC INSULATION	2.6.3
BY HAND	2.8.4
CLASS I	2.6.1
CLASS II	2.6.2
CLEARANCE	2.6.11
CONDUCTIVITY CONNECTED TO THE MAINS	2.4.4
CONDUCTIVE PATTERN	2.7.13
CREEPAGE DISTANCE	2.6.12
DIRECTLY CONNECTED TO THE MAINS	2.4.3
DOUBLE INSULATION	2.6.4
ELECTRONIC MUSICAL INSTRUMENT	2.2.2
FIRE ENCLOSURE	2.8.10
HAZARDOUS LIVE	2.6.10
IMAGERY	2.2.8
INSTRUCTED PERSON	2.8.6
ISOLATING TRANSFORMER	2.7.1
LASER	2.2.7
LASER SYSTEM	2.2.6
LOAD TRANSDUCER	2.5.4
MAINS	2.4.1
<u>MAJOR ENCLOSURE PART</u>	<u>2.8.12</u>
MANUALLY OPERATED MECHANICAL SWITCH	2.7.10
MACRO-DISCONNECTION	2.7.7
NOISE SIGNAL	2.5.2
NON-CLIPPED OUTPUT POWER	2.3.4
OPERATING VOLTAGE	2.3.2
PERMANENTLY CONNECTED APPARATUS	2.4.2
PINK NOISE	2.5.1
PORTABLE APPARATUS	2.2.10
POTENTIAL IGNITION SOURCE	2.8.11
PRINTED BOARD	2.7.12
PROTECTIVE EARTH TERMINAL	2.4.6
PROTECTIVE SCREENING	2.6.8
PROTECTIVE SEPARATION	2.6.7
PTC-S THERMISTOR	2.7.8
RATED CURRENT CONSUMPTION	2.3.6
RATED LOAD IMPEDANCE	2.3.5
RATED SUPPLY VOLTAGE	2.3.1
REINFORCED INSULATION	2.6.6
REMOTE CONTROL	2.2.9
RIPPLE FREE	2.3.3
ROUTINE TEST	2.8.2
SAFETY INTERLOCK	2.7.9
SEPARATING TRANSFORMER	2.7.2
SKILLED PERSON	2.8.5
SOURCE TRANSDUCER	2.5.3

SPECIAL SUPPLY APPARATUS	2.2.5
STAND-BY	2.8.8
<u>STATIONARY APPARATUS</u>	<u>2.4.8</u>
SUPPLEMENTARY INSULATION	2.6.5
SUPPLY APPARATUS	2.2.3
SUPPLY APPARATUS FOR GENERAL USE	2.2.4
TELECOMMUNICATION NETWORK	2.4.7
TERMINAL	2.4.5
THERMAL CUT-OUT	2.7.4
THERMAL LINK	2.7.5
THERMAL RELEASE	2.7.3
TOUCH CURRENT	2.6.9
TRANSPORTABLE APPARATUS	2.2.11
TRIP-FREE	2.7.6
TYPE TEST	2.8.1
USER	2.8.7
WOOD-BASED MATERIAL	2.8.9

## 2.2 Types of apparatus

### 2.2.1

#### AUDIO AMPLIFIER

either an independent audio signal amplifying apparatus or the audio signal amplifying part of an apparatus to which this standard applies

### 2.2.2

#### ELECTRONIC MUSICAL INSTRUMENT

electronic apparatus such as an electronic organ, electronic piano or music synthesizer that produces music under the control of the player

### 2.2.3

#### SUPPLY APPARATUS

apparatus which takes power from the MAINS and from which one or more other apparatus are fed

### 2.2.4

#### SUPPLY APPARATUS FOR GENERAL USE

SUPPLY APPARATUS which can be used without special measures not only for the supply of apparatus within the scope of this standard, but also for the supply of other appliances or devices, for example pocket-calculators

### 2.2.5

#### SPECIAL SUPPLY APPARATUS

SUPPLY APPARATUS which is designed to be used only for the supply of specified apparatus within the scope of this standard

### 2.2.6

#### LASER SYSTEM

LASER in combination with an appropriate laser energy source with or without additional incorporated components (see 3.44 of IEC 60825-1)

**2.2.7**

## LASER

device which can be made to produce or amplify electromagnetic radiation in the wavelength range from 180 nm to 1 mm primarily by the process of controlled stimulated emission (see 3.36 of IEC 60825-1)

**2.2.8**

## IMAGERY

processing, editing, manipulation and/or storing of video signals

**2.2.9**

## REMOTE CONTROL

controlling of an apparatus from a distance, for example mechanically, electrically, acoustically or by means of radiation

**2.2.10**

## PORTABLE APPARATUS

specific apparatus designed to be carried easily BY HAND, the mass of which does not exceed 18 kg

**2.2.11**

## TRANSPORTABLE APPARATUS

apparatus specifically designed to be moved frequently from place to place

**2.3 Ratings and electrical values****2.3.1**

## RATED SUPPLY VOLTAGE

supply voltage or voltage range (for three-phase supply, the line-to-line voltage) for which the manufacturer has designed the apparatus

**2.3.2**

## OPERATING VOLTAGE

highest voltage, non-repetitive transients being disregarded, to which the insulation under consideration is, or can be subjected when the apparatus is operating at its RATED SUPPLY VOLTAGE under normal operating conditions

**2.3.3**

## RIPPLE FREE

d.c. voltage with a r.m.s. value of a ripple content of not more than 10% of the d.c. component. The maximum peak voltage does not exceed 140 V for a nominal 120 V ripple free d.c. system, and does not exceed 70 V for a nominal 60 V ripple free d.c. system

**2.3.4**

## NON-CLIPPED OUTPUT POWER

sine-wave power dissipated in the RATED LOAD IMPEDANCE, measured at 1000 Hz at the onset of clipping on either one, or both peaks

In cases where an amplifier is not intended for operation at 1000 Hz, a test frequency at the peak response shall be used

**2.3.5**

## RATED LOAD IMPEDANCE

resistance, specified by the manufacturer, by which an output circuit should be terminated

**2.3.6**

## RATED CURRENT CONSUMPTION

current consumption of an apparatus operating at its RATED SUPPLY VOLTAGE under normal operating conditions

**2.3.7**

## AVAILABLE POWER

maximum power which can be drawn from the supplying circuit through a resistive load whose value is chosen to maximize the power for more than 2 min when the circuit supplied is disconnected (see figure 1)

**2.4 Supply and external connections****2.4.1**

## MAINS

power source with a nominal voltage of more than 35 V (peak) a.c or d.c. which is not used solely to supply apparatus specified in 1.1.1

**2.4.2**

## PERMANENTLY CONNECTED APPARATUS

apparatus which is intended for connection to the MAINS by a connection which cannot be loosened BY HAND

**2.4.3**

## DIRECTLY CONNECTED TO THE MAINS

electrical connection with the MAINS in such a way that a connection to either pole of the MAINS causes in that connection a permanent current equal to or greater than 9 A, protective devices in the apparatus being not short-circuited

NOTE – A current of 9 A is chosen as the minimum breaking current of a 6 A fuse.

**2.4.4**

## CONDUCTIVELY CONNECTED TO THE MAINS

electrical connection with the MAINS in such a way that a connection through a resistance of 2000  $\Omega$  to either pole of the MAINS causes in that resistance a permanent current greater than 0.7 mA (peak), the apparatus not being connected to earth

**2.4.5**

## TERMINAL

part of an apparatus by which connection is made to external conductors or other apparatus. It may contain several contacts

**2.4.6**

## PROTECTIVE EARTH TERMINAL

TERMINAL to which parts are connected which must be connected to earth for safety reasons

### 2.4.7

TELECOMMUNICATION NETWORK

metallically-terminated circuit intended to carry TELECOMMUNICATION SIGNALS for voice, data or other communication. Such networks may be publicly or privately owned. They may be subjected to overvoltages due to atmospheric discharges and power line failures

NOTE – It is assumed that adequate measures according to ITU-T Recommendation K.11 have been taken to reduce the risk that over-voltages presented to apparatus exceed 1.5 kV (peak).

Excluded are:

- MAINS systems for supply, transmission and distribution of electrical power, used as telecommunication transmission medium;
- TV distribution systems using cable;
- public or private mobile radio systems;
- radio paging systems.

### 2.4.8 DU

STATIONARY APPARATUS

a cord and plug connected apparatus that is intended to be fastened in place or located in a dedicated space

2.4.8 revised June 23, 2000

## 2.5 Signals, sources, loads

### 2.5.1

PINK NOISE

NOISE SIGNAL whose energy per unit bandwidth ( $\Delta W/\Delta f$ ) is inversely proportional to frequency

### 2.5.2

NOISE SIGNAL

stationary random signal having normal probability distribution of instantaneous values. Unless otherwise stated, the mean value is zero

### 2.5.3

SOURCE TRANSDUCER

apparatus intended to convert the energy of a nonelectrical signal to electrical energy

NOTE – Examples are microphone, image sensor, magnetic reproducing head, laser-pickup.

### 2.5.4

LOAD TRANSDUCER

apparatus intended to convert the energy of an electrical signal into another form of energy

NOTE – Examples are loudspeaker, picture tube, liquid crystal display, magnetic recording head.

## 2.6 Protection against electric shock, insulations

### 2.6.1

CLASS I

design in which protection against electric shock does not rely on BASIC INSULATION only, but which includes an additional safety precaution in such a way that means are provided for the connection of ACCESSIBLE conductive parts to the protective (earthing) conductor in the fixed wiring of the installation, in such a way that ACCESSIBLE conductive parts cannot become HAZARDOUS LIVE in the event of a failure of the BASIC INSULATION (see 3.2 of IEC 60536)

NOTE – Such a design may have parts of CLASS II.

### 2.6.2

CLASS II

design in which protection against electric shock does not rely on BASIC INSULATION only, but in which additional safety precautions, such as DOUBLE INSULATION OR REINFORCED INSULATION, are provided, there being no provision for protective earthing or reliance upon installation conditions (see 3.3 of IEC 60536)

### 2.6.3

BASIC INSULATION

insulation applied to HAZARDOUS LIVE parts to provide basic protection against electric shock

NOTE – BASIC INSULATION does not necessarily include insulation used exclusively for functional purposes.

### 2.6.4

DOUBLE INSULATION

insulation comprising both BASIC INSULATION and SUPPLEMENTARY INSULATION (see 2.3 of IEC 60536)

### 2.6.5

SUPPLEMENTARY INSULATION

independent insulation applied in addition to BASIC INSULATION in order to provide protection against electric shock in the event of a failure of the BASIC INSULATION (see 2.2 of IEC 60536)

### 2.6.6

REINFORCED INSULATION

single insulation applied to HAZARDOUS LIVE parts which provides a degree of protection against electric shock equivalent to DOUBLE INSULATION

NOTE – REINFORCED INSULATION may comprise several layers which cannot be tested singly as BASIC INSULATION OR SUPPLEMENTARY INSULATION.

### 2.6.7

PROTECTIVE SEPARATION

separation between circuits by means of basic and supplementary protection (BASIC INSULATION plus SUPPLEMENTARY INSULATION or plus PROTECTIVE SCREENING) or by an equivalent protective provision, for example REINFORCED INSULATION (see 2.9 of IEC 60536-2)

### 2.6.8

PROTECTIVE SCREENING

separation from HAZARDOUS LIVE parts by means of an interposed conductive screen, connected to the PROTECTIVE EARTH TERMINAL



**2.6.9**

TOUCH CURRENT

current which passes through the human body when it touches one or more ACCESSIBLE parts of an apparatus under normal operating or fault conditions

**2.6.10**

HAZARDOUS LIVE

electrical condition of an object from which a hazardous TOUCH CURRENT (electric shock) could be drawn (see 9.1.1)

**2.6.11**

CLEARANCE

shortest distance in air between two conductive parts

**2.6.12**

CREEPAGE DISTANCE

shortest distance along the surface of an insulating material between two conductive parts

**2.7 Components****2.7.1**

ISOLATING TRANSFORMER

transformer with PROTECTIVE SEPARATION between the input and output windings.

**2.7.2**

SEPARATING TRANSFORMER

transformer, the input windings of which are separated from the output windings by at least BASIC INSULATION.

NOTE – Such transformers may have parts meeting the requirements of ISOLATING TRANSFORMERS.

**2.7.3**

THERMAL RELEASE

device which prevents the maintenance of excessively high temperatures in certain parts of the apparatus by disconnecting these parts from their supply

NOTE – PTC-S THERMISTORS (see 2.7.8) are not THERMAL RELEASES in the sense of this definition.

**2.7.4**

THERMAL CUT-OUT

THERMAL RELEASE with reset which has no provision for temperature setting by the USER

NOTE – A THERMAL CUT-OUT may be of the automatic or of the manual reset type.

**2.7.5**

THERMAL LINK

THERMAL RELEASE without reset, which operates only once and then requires partial or complete replacement

**2.7.6**

TRIP-FREE

automatic action, with a reset actuating member, so designed that the automatic action is independent of manipulation or position of the reset mechanism

**2.7.7**

MICRO-DISCONNECTION

adequate contact separation so as to ensure functional security

NOTE – There is a requirement for the dielectric strength of the contact gap but no dimensional requirement.

**2.7.8**

PTC-S THERMISTOR

thermally sensitive semiconductor resistor, which shows a step-like increase in its resistance when the increasing temperature reaches a specific value. The change of temperature is obtained either by the flow of current through the thermosensitive element, or by a change in the ambient temperature, or by a combination of both.

**2.7.9**

SAFETY INTERLOCK

means either of preventing access to a hazardous area until the hazard is removed or of automatically removing the hazardous condition when access is gained

**2.7.10**

MANUALLY OPERATED MECHANICAL SWITCH

device operated BY HAND, not incorporating semiconductors, and situated anywhere in the circuit of the apparatus, which can interrupt the intended function, such as sound and/or vision by moving contacts

NOTE – Examples of MANUALLY OPERATED MECHANICAL SWITCHES are single-pole or ALL-POLE MAINS SWITCHES, functional switches and switching systems which for example can be a combination of relays and switches controlling the relays.

**2.7.11**

ALL-POLE MAINS SWITCH

MANUALLY OPERATED MECHANICAL SWITCH which interrupts all poles of the MAINS supply except the protective earth conductor

**2.7.12**

PRINTED BOARD

base material cut to size, containing all needed holes and bearing at least one CONDUCTIVE PATTERN

**2.7.13**

CONDUCTIVE PATTERN

configuration formed by electrically conductive material of a PRINTED BOARD.

**2.8 Miscellaneous****2.8.1**

TYPE TEST

test of one or more specimens made on a certain design to show that the design meets all requirements of this standard

**2.8.2**

ROUTINE TEST

test to which each specimen is subjected during or after manufacture to ascertain whether it complies with certain criteria

### 2.8.3 DU

ACCESSIBLE

possibility of touching by the test finger according to IEC 61032, test probe-B the articulated finger probe with web stop as shown in figure 14.

NOTE – Any ACCESSIBLE area of a non-conductive part is considered as being covered with a conductive layer (see figure 3 as an example).

### 2.8.4

BY HAND

operation does not require the use of any object such as a tool, coin, etc.

### 2.8.5

SKILLED PERSON

person with relevant education and experience to enable him or her to avoid dangers and to prevent risks which electricity may create

### 2.8.6

INSTRUCTED PERSON

person adequately advised or supervised by SKILLED PERSONS to enable him or her to avoid dangers and to prevent risks which electricity may create

### 2.8.7

USER

any person, other than a SKILLED PERSON OR AN INSTRUCTED PERSON, who can come into contact with the apparatus

### 2.8.8

STAND-BY

operating condition where the main functions, such as sound and/or vision, are switched-off and where the apparatus is only partly in operation. In this condition, permanent functions, such as a clock are maintained and it allows the apparatus to be brought into full operation, for example by REMOTE CONTROL or automatically

### 2.8.9

WOOD-BASED MATERIAL

material in which the main ingredient is machined natural wood, coupled with a binder

NOTE – Examples of WOOD-BASED MATERIAL are materials incorporating ground or chipped wood, such as hard fibre board or chip board

### 2.8.10

FIRE ENCLOSURE

part of the apparatus intended to minimize the spread of fire or flames from within

### 2.8.11

POTENTIAL IGNITION SOURCE

a possible fault such as a faulty contact or interruption in an electrical connection, including a CONDUCTIVE PATTERN ON PRINTED BOARDS, which can start a fire if, under normal operating conditions, the open circuit voltage exceeds 50 V (peak) a.c. or d.c. and the product of this open circuit voltage and the measured current through this possible fault exceeds 15 VA

### **2.8.12 DU**

#### MAJOR ENCLOSURE PART

a part that forms more than 50% of the area of any surface of an enclosure that is required to comply with the requirements to reduce the risk of fire, electric shock, or injury to persons

### **2.8.13 DU**

#### ACCESSORY

a part intended for use with an apparatus when it is packed with the apparatus, when it is referenced by the manufacturer's name and catalog number in an apparatus marking, or when the apparatus manufacturer's literature indicates or implies use of the accessory by manufacturer's name and catalog number with the apparatus

## **3 General requirements**

**3.1** The apparatus shall be so designed and constructed as to present no danger when used for its intended purpose, either in normal operating conditions or under fault conditions, particularly providing protection against:

- hazardous currents passing through the human body (electric shock);
- excessive temperatures;
- hazardous radiations;
- effects of implosion and explosion;
- mechanical instability;
- injury by mechanical parts;
- start and spread of fire.

In general, compliance is checked under normal operating conditions and under fault conditions, as specified in 4.2 and 4.3, by carrying out all the relevant tests specified.

NOTE – Australia has special requirements with respect to d.c. components in the equipment neutral conductor.

**3.2** Apparatus designed to be fed from the MAINS shall be constructed according to the requirements of CLASS I, OR CLASS II apparatus.

## **4 General test conditions**

### **4.1 Conduct of tests**

**4.1.1** *Tests according to this standard are TYPE TESTS.*

NOTE – FOR ROUTINE TEST, recommendations are given in annex N.

**4.1.2** *The sample or samples under test shall be representative of the apparatus the USER would receive, or shall be the actual equipment ready for shipment to the USER.*

*As an alternative to carrying out tests on the complete apparatus, tests may be carried out separately on circuits, components or sub-assemblies outside the apparatus, provided that inspection of the apparatus and circuit arrangements ensures that such testing will indicate that the assembled apparatus would conform to the requirements of this standard.*

*If any such test indicates a likelihood of non-compliance in the complete apparatus, the test shall be repeated in the apparatus.*

*If a test specified in this standard could be destructive, it is permitted to use a physical model to represent the condition to be evaluated.*

NOTE 1 – The tests should be carried out in the following order:

- component or material pre-selection;
- component or sub-assembly bench tests;
- tests where the apparatus is not energized;
- live tests:
  - under normal operating conditions,
  - under abnormal operating conditions,
  - involving likely destruction.

NOTE 2 – In view of the amount of resources involved in testing and in order to minimize waste, it is recommended that all parties concerned jointly consider the test programme, the test samples and the test sequence.

**4.1.3** *Unless otherwise specified, the tests are carried out under normal operating conditions at:*

- *an ambient temperature between 15°C and 35°C, and*
- *a relative humidity of 75% maximum.*

**4.1.4** *Any position of intended use of the apparatus, normal ventilation not being impeded.*

*The temperature measurements shall be carried out with the apparatus positioned in accordance with the instructions for use provided by the manufacturer, or, in the absence of instructions, the apparatus shall be positioned 5 cm behind the front edge of an open-fronted wooden test box with, 1 cm free space along the sides and top, and 5 cm depth behind the apparatus.*

*Tests on apparatus, intended to be part of an assembly not provided by the apparatus manufacturer, shall be carried out according to the instructions for use provided by the manufacturer, specifically those dealing with the proper ventilation of the apparatus.*

**4.1.5** *The characteristics of the supply source, except those specified in 4.2.1, used during the tests shall not appreciably influence the test results.*

*Examples of such characteristics are source impedance and waveform.*

**4.1.6** Where relevant, a standard signal consisting of PINK NOISE, band-limited by a filter whose response conforms to that given in C.1 in annex C.

NOTE – If appropriate, the standard signal may be used to modulate a carrier wave.

The output measuring equipment shall indicate true r.m.s. values for crest factors up to at least 3, and the frequency response shall conform to that shown in annex C.

**4.1.7** The a.c. values given in this standard are r.m.s. values, unless specified otherwise.

The d.c. values given in this standard are RIPPLE FREE values.

## **4.2 Normal operating conditions**

Normal operating conditions are the most unfavourable combination of the following conditions.

**4.2.1 DU** The apparatus is connected to a supply voltage of 0.9 times or ~~1.06~~ 1.1 times of any RATED SUPPLY VOLTAGE for which the apparatus is designed.

In case of doubt, tests may also be performed at the value of any RATED SUPPLY VOLTAGE.

For apparatus having a RATED SUPPLY VOLTAGE range not requiring the adjustment of a voltage setting device, the apparatus is connected to a supply voltage of 0.9 times the lower limit or ~~1.06~~ 1.1 times the upper limit of any RATED SUPPLY VOLTAGE range; moreover, the apparatus is connected to any nominal supply voltage within the RATED SUPPLY VOLTAGE range marked on the apparatus.

Any rated supply frequency marked on the apparatus is used.

For a.c./d.c. apparatus, an a.c. or d.c. supply is used.

For d.c. supply any polarity is used, unless this is prevented by the construction of the apparatus.

NOTE - In the U.S. the RATED SUPPLY VOLTAGE for single phase apparatus is assumed to be 120 V or 120/240 V.

**4.2.2** Any position of controls which are ACCESSIBLE to the USER for adjustment BY HAND, including REMOTE CONTROLS, excluding voltage setting devices complying with 14.8 and volume controls and tone controls.

Any cable connected REMOTE CONTROL device, detachable by a connector or a similar device, is connected or not.

A cover, enclosing a LASER SYSTEM, which can be opened BY HAND, is opened fully, opened partly or closed.

**4.2.3** In the case of single-phase supply any earth TERMINAL and any PROTECTIVE EARTH TERMINAL may be connected to either pole of the isolated supply source used during the test.

In the case of a supply other than single phase any earth TERMINAL and any PROTECTIVE EARTH TERMINAL may be connected to the neutral or to any phase of the isolated supply source used during the test.

**4.2.4 DU** In addition, for an AUDIO AMPLIFIER:

a) The apparatus is operated in such a way as to deliver one-eighth of the NON-CLIPPED OUTPUT POWER to the RATED LOAD IMPEDANCE using the standard signal described in 4.1.6 with the tone controls set to their mid position.

When a redundant protection circuit, THERMAL CUT-OUT with automatic reset, or PTC-S THERMISTOR operates while the apparatus is delivering one-eighth of the NON-CLIPPED OUTPUT POWER to the RATED LOAD IMPEDANCE, the output power is to be reduced to the maximum power that permits continuous operation of the apparatus.

Where the NON-CLIPPED OUTPUT POWER cannot be obtained using the standard signal, one-eighth of the maximum attainable out power is taken.

When conducting the heating test according to 7.1 or when determining whether a part or TERMINAL contact is HAZARDOUS LIVE according to 9.1.1 and 11.1, at the manufacturer's option the apparatus may also be operated in such a way as to deliver the NON-CLIPPED OUTPUT POWER to the RATED LOAD IMPEDANCE using a sinusoidal signal of 1000 Hz or another frequency corresponding to the mid-frequency of the relevant amplifier part of the apparatus.

b) The most unfavourable RATED LOAD IMPEDANCE of any output circuit is connected or not.

c) Organs or similar instruments which have a tone-generator unit are operated with any combination of two bass pedal keys, if any, and ten manual keys depressed, and all stops and tabs which can increase the output power are activated.

For AUDIO AMPLIFIERS used in an ELECTRONIC MUSICAL INSTRUMENT which does not generate a continuous tone, the standard signal described in 4.1.6 is applied to the signal input TERMINAL or to the appropriate input stage of the AUDIO AMPLIFIER.

**4.2.4.1 DR** The measured input power or current shall not exceed the marked input rating by more than 5% when the apparatus is operated to produce maximum power input under normal operating conditions.

**4.2.4.2 DU** An apparatus with multiple modes of operation, multiple signal input sources, or both, is to be operated using each mode of operation or signal input source separately, or in combination, according to the manufacturer's instructions to produce the maximum power input.

**4.2.5** For apparatus incorporating motors, load conditions for the motor are chosen which may occur during intended use, including stalling BY HAND if this is possible.

**4.2.6** An apparatus supplying power to other apparatus is loaded to give its rated power or not loaded.

**4.2.7** A SUPPLY APPARATUS to be used inside apparatus for which it is intended exclusively, is tested within such apparatus after installation according to the manufacturer's instruction for use.

**4.2.8** In addition for Citizen's Band apparatus, the RATED LOAD IMPEDANCE is connected or not to the antenna TERMINAL or, if applicable, a telescopic antenna extended to any length. The transmitting test conditions are specified in IEC 61149.

#### **4.2.9 Antenna positioners**

**4.2.9.1** In addition for antenna positioners in combination with their control and SUPPLY APPARATUS:

– four consecutive movements from one endstop to the opposite endstop;

– 15 min resting period.

The movements and the resting period are repeated as many times as necessary for the relevant tests. For temperature measurements the movements and the resting periods are repeated until a steady state of temperature has been reached but not longer than 4 h.

After the last movement period, the 15 min resting period does not apply to the temperature measurements.

**4.2.9.2** In addition, for satellite antenna positioners consisting of a power supply and control unit without a motor drive system, the power supply unit shall be loaded in accordance with the marked output rating and operated with a duty cycle of 5 min on, and 15 min off.

**4.2.10** Apparatus designed to be supplied exclusively by a SPECIAL SUPPLY APPARATUS specified by the manufacturer of the apparatus, shall be tested together with this SPECIAL SUPPLY APPARATUS. The supply voltage for the SPECIAL SUPPLY APPARATUS is determined in accordance with 4.2.1.

Where a voltage setting device for the output voltage of the SPECIAL SUPPLY APPARATUS is provided, it shall be adjusted to the RATED SUPPLY VOLTAGE of the apparatus under test.

**4.2.11** Apparatus, which can be supplied by SUPPLY APPARATUS FOR GENERAL USE, shall be supplied by a test power supply according to table 1 corresponding to the RATED SUPPLY VOLTAGE of the apparatus under test. The values of no-load voltage given in table 1 are subject to the under- and over-voltage provisions specified in 4.2.1.

**4.2.12** Apparatus intended to be used with optional detachable legs or stands supplied by the manufacturer of the apparatus are tested with or without legs or stands fitted.

**Table 1 DU – Test power supply**

RATED SUPPLY VOLTAGE V d-c	Nominal no-load voltage V d-c	Internal resistance $\Omega$
1.5	2.25 <u>1.60</u>	0.75 <u>0.003</u>
3.0	4.50 <u>3.19</u>	1.50 <u>0.006</u>
4.5	6.75 <u>4.79</u>	2.25 <u>0.010</u>
6.0	9.00 <u>6.39</u>	3.00 <u>0.013</u>
7.5	11.25 <u>7.98</u>	3.75 <u>0.016</u>
9.0	13.50 <u>9.57</u>	4.50 <u>0.019</u>
12.0	18.00 <u>12.77</u>	6.00 <u>0.026</u>

NOTE – Table 1 provides a standardized set of supply parameters intended to represent those found in SUPPLY APPARATUS FOR GENERAL USE in the range 1.5 V to 12 V and with a rated output current of 1 A a 30 A minimum supply source with 6 percent regulation.  
Supply parameters for voltages >12 V and output currents >1 A are under consideration.

### 4.3 Fault conditions

For operation under fault conditions, in addition to the normal operating conditions mentioned in 4.2, each of the following conditions is applied in turn and, associated with it, those other fault conditions which are a logical consequence.

NOTE 1 – The logical consequences of a fault condition are those which occur when a fault is applied



*Circuits, or parts of a circuit supplied with an open circuit voltage not exceeding 35 V (peak) a.c. or d.c. and not generating voltages above that value, are not considered to present a fire hazard if the current which may be drawn from the supplying circuit for more than 2 min at any load, including short-circuit, is limited to not more than 0.2 A. Such supplied circuits are not subject to fault conditions testing.*

*An example of a test circuit to measure the voltage and the current is given in figure 1.*

NOTE 2 – Examination of the apparatus and all its circuit diagrams, excluding the internal circuit diagrams of integrated circuits, generally shows the fault conditions which are likely to create a hazard and which need to be applied. These are applied in sequence, in the order which is most convenient.

NOTE 3 – When carrying out the examination in note 2, the operating characteristics of integrated circuits are taken into consideration.

NOTE 4 – The fault tests are only to be made in the wooden test box mentioned in 4.1.4, if there is a possibility that this will influence the results.

*When a specified fault condition test is carried out, it can cause consequential faults which either interrupt or short circuit a component. In case of doubt, the fault condition test shall be repeated up to two more times with replacement components in order to check that the same result is always obtained. Should this not be the case, the most unfavourable consequential fault, whether interruption or short circuit, shall be applied together with the specified fault condition.*

**4.3.1** *Short-circuit across CLEARANCES and CREEPAGE DISTANCES if they are less than the values specified in clause 13 for BASIC and SUPPLEMENTARY INSULATION.*

**4.3.2** *Short-circuit across parts of insulating material, the short-circuiting of which might cause an infringement of the requirements regarding protection against electric shock hazard or overheating, with the exception of insulating parts which comply with the requirements of 10.3.*

NOTE – This subclause does not imply a need to short-circuit the insulation between turns of coils.

**4.3.3** *Short-circuit, or if applicable, interruption of:*

- heaters of electronic tubes;*
- insulation between heaters and cathodes of electronic tubes;*
- spacings in electronic tubes, excluding picture tubes;*
- semiconductor devices, one lead at a time interrupted or any two leads connected together in turn (but see 4.3.4 d)).*

NOTE – If electronic tubes are so constructed that a short circuit between certain electrodes is highly improbable or even impossible, the electrodes concerned need not be short-circuited.

**4.3.4** *DC Short-circuit or disconnection, whichever is more unfavourable, of resistors, capacitors, windings (for example transformers, degaussing coils), loudspeakers, optocouplers, varistors or non-linear passive components, the short-circuiting or disconnection of which might cause an infringement of the requirements regarding protection against electric shock or overheating.*

*These fault conditions do not apply to:*

- a) resistors complying with the requirements of 14.1 and, as far as applicable, of 11.2;
- b) PTC-S THERMISTORS complying with ~~IEC 60738~~ UL 1434;
- c) capacitors and RC-units complying with the requirements of 14.2, provided that the voltage at their terminations does not exceed their rated voltage and that their application is in accordance with 8.5 or 8.6;
- d) the insulation between the input and output terminations of optocouplers complying with the requirements of 14.11;
- e) windings and the insulation of transformers and other windings mentioned in 14.3 complying with the requirements of that subclause.

**4.3.5** For apparatus containing an AUDIO AMPLIFIER, using the standard signal described in 4.1.6 so as to deliver the most unfavourable output power from zero up to the maximum attainable output power to the RATED LOAD IMPEDANCE or, if applicable, to the most unfavourable load impedance connected to the output TERMINALS including short-circuit and open circuit.

**4.3.6 DU** Motors are stalled if this is possible during the use of the apparatus by internal or external influences.

Solenoids shall be tested with the plunger blocked in the de-energized (at-rest) state.

**4.3.7** Motors, relay coils or the like, intended for short-time or intermittent operation, are operated continuously if this can occur during operation of the apparatus.

**4.3.8** The apparatus is connected simultaneously to alternative types of supply unless this is prevented by the construction.

**4.3.9 DU** Output TERMINALS of apparatus supplying power to other apparatus, except MAINS socket-outlets DIRECTLY CONNECTED TO THE MAINS, are connected to the most unfavourable load impedance, including short circuit.

External MAINS socket-outlets are separately overloaded to 110% of the current rating for the socket outlet configuration.

**4.3.10** Each group of ventilation openings that are likely to be covered simultaneously, shall be covered in turn and tested separately.

Ventilating openings that are likely to be covered simultaneously are:

- openings on top of the apparatus, for example by a newspaper; or
- openings on the sides and the back, excluding the front, for example when pushed into a hanging curtain.

**4.3.11** If it is possible to insert USER replaceable batteries with reversed polarity, the apparatus is tested with one or more batteries with both intended and reversed polarity.

NOTE – CAUTION, there is a danger of explosion when this test is applied.

**4.3.12** For Citizen's Band apparatus, the most unfavourable load impedance including short circuit is connected to the antenna *TERMINAL* or to the antenna itself, for example a telescopic antenna, when no antenna *TERMINAL* is provided. The transmitting test conditions are specified in IEC 61149.

**4.3.13 DU** For *PORTABLE APPARATUS* apparatus to be supplied from an a.c. *MAINS* and provided with a voltage setting device to be set by the *USER*, connection to a supply voltage of 250 V a.c., with the *MAINS* voltage setting device at the most unfavourable position.

**4.3.14** Apparatus designed to be supplied by a *SPECIAL SUPPLY APPARATUS* with a voltage setting device for the output voltage, specified by the manufacturer of the apparatus, shall be tested by adjusting this voltage setting device to any output voltage.

During this test, 4.2.1 is applied, except that the *SPECIAL SUPPLY APPARATUS* is fed by its *RATED SUPPLY VOLTAGE*.

The test need not be made if the current consumption of the apparatus under test cannot exceed 0.2 A for more than 2 min, for example by the operation of a fuse.

**4.3.15** Apparatus which can be supplied by *SUPPLY APPARATUS FOR GENERAL USE* shall be tested by using a test power supply as specified in table 1 step by step upwards, starting with the value one step above the value specified for the *RATED SUPPLY VOLTAGE* of the apparatus under test.

This test is not applied to apparatus having a *RATED SUPPLY VOLTAGE* equal to or higher than the maximum *RATED SUPPLY VOLTAGE* in table 1.

During this test, 4.2.1 is applied, except that the no-load voltages have their nominal values.

The test need not be made if the current consumption of the apparatus under test cannot exceed 0.2 A for more than 2 min, for example by the operation of a fuse.

**4.3.16 DU** The battery-supply cord of an apparatus that is intended to be connected to an external battery is to be short-circuited at any point on the load side of the overcurrent protective device in the cord while the cord is connected to the battery supplied with the apparatus or while the cord is connected to a power supply as identified in table 1 with the output voltage equivalent to the battery voltage.

## 5 Markings and instructions

Markings shall be permanent, comprehensible and easily discernible on the apparatus when ready for use.

The information should preferably be on the exterior of the apparatus, excluding the bottom. It is, however, permissible to have it in an area that is easily *ACCESSIBLE BY HAND*, for example under a lid, or on the exterior of the bottom of a *PORTABLE APPARATUS* or an apparatus with a mass not exceeding 7 kg, provided that the location of the marking is given in the instructions for use.

Compliance is checked by inspection and by rubbing the marking *BY HAND* for 15 s with a piece of cloth soaked with water and, at a different place or on a second sample, for 15 s with a piece of cloth soaked with petroleum spirit. After this the marking shall be legible; it shall not be easily possible to remove marking plates and they shall show no curling.

Petroleum spirit, to be used for reference purposes is defined as follows:

*The petroleum spirit is an aliphatic solvent hexane having a maximum aromatics content of 0.1% by volume, a kauri-butanol value of 29, an initial boiling point of approximately 65°C, a dry-point of approximately 69°C and a specific mass of approximately 0.7 kg/l.*

Letter symbols for quantities and units shall be in accordance with IEC 60027.





Graphical symbols shall be in accordance with IEC 60417 and ISO 7000 as appropriate.

The on-position, and where relevant, the off-position of switches shall be indicated in accordance with 14.6.3.

*Compliance is checked by inspection.*

## 5.1 DR DU Identification and supply ratings

The apparatus shall be marked with the following:

- a) maker's or responsible vendor's name, trade mark or identification mark;
- b) model number or type reference;
- c) the symbol for CLASS II, if applicable:  (60417-2-IEC-5172)
- d) NOTE – Marking for apparatus designed for use in tropical climates is under consideration.
- e) Nature of supply:
  - a.c. only with the symbol:  (60417-2-IEC-5032)
  - d.c. only with the symbol:  (60417-2-IEC-5031)
  - a.c. or d.c. with the symbol:  (60417-2-IEC-5033)
  - for three-phase systems, reference shall be made to IEC 61293.
- f) RATED SUPPLY VOLTAGE or range of the RATED SUPPLY VOLTAGES which can be applied without operating a voltage setting device.

Apparatus which can be set to different RATED SUPPLY VOLTAGES or ranges of RATED SUPPLY VOLTAGES shall be so constructed that the indication of the voltage or range of voltages to which the apparatus is set, is discernible on the apparatus when ready for use;

A solidus shall be used for USER selectable ratings, for example "110/230 V" and a hyphen shall be used for a rating range, for example "110-230 V";

g) Rated MAINS frequency (or range of frequencies) in hertz. ~~if safety is dependent on the use of the correct MAINS frequency.~~

h) RATED CURRENT CONSUMPTION or rated power consumption of apparatus. ~~which can be supplied by SUPPLY APPARATUS FOR GENERAL USE. As an alternative the information may be given in the instruction manual.~~

i) Power consumption marking for apparatus intended for connection to an a.c. MAINS supply other than single phase.

NOTE – Details for the measurement of the power consumption are under consideration.

j) The date or a dating code not exceeding any three consecutive months of manufacture. The dating code shall be in an established alphanumeric code affirmed by the manufacturer. The coding system shall have a minimum 10 year repetition cycle.

k) A distinctive identification to identify the factory of origin, when the same apparatus is produced at more than one factory.

l) When the enclosure of an apparatus provides the user with a means for access to parts which involve the risk of electric shock, the combination of the two graphical symbols and the supplemental marking – “CAUTION – RISK OF ELECTRIC SHOCK – DO NOT OPEN” – depicted in figure 15 shall be provided on at least one surface of the apparatus enclosure through which the USER gains access to the interior.

All other enclosure surfaces that provide a means for access to the interior of the apparatus for servicing purposes shall be marked either as indicated in figure 15, or with the graphical symbol depicted in figure 16 adjacent to one of the enclosure fasteners on that surface.

m) An audio and/or video system consisting of an equipment rack and one or more audio or video components shall be marked to identify the individual audio and video component type(s) and model number(s) which have been evaluated as part of the system. The marking shall be provided on a tag that is permanently attached to the rack. The tag shall be of substantial material such as cardboard, cloth, plastic or the equivalent to provide mechanical strength and to discourage removal. The tag shall have a hole and be secured to the rack by a plastic strap or the equivalent, or be provided with adhesive backing and secured to the rack as a flag. The tag shall be factory applied and not installed by the user.

n) Apparatus having leakage current levels greater than 0.75 MIU and equal to or less than 1.5 MIU, as permitted in 9.1.1, shall be provided with the word “CAUTION” and the following marking or equivalent: “TO REDUCE THE RISK OF ELECTRIC SHOCK, GROUNDING OF THE CENTER PIN OF THIS PLUG MUST BE MAINTAINED.” The marking shall be on a tag which shall be of substantial material such as cardboard, cloth, plastic or the equivalent to provide mechanical strength and to discourage removal. The tag shall have a hole and be secured to the cord by a plastic strap or the equivalent.

*Compliance is checked by inspection.*

## 5.2 DR DU TERMINALS

5.2 revised June 23, 2000

TERMINALS shall be marked as follows:

a) The wiring TERMINAL intended for connection of the protective earthing conductor associated with the supply wiring: ⊕ (60417-2-IEC-5019)

This symbol shall not be used for other earthing TERMINALS.

b) TERMINALS which are HAZARDOUS LIVE under normal operating conditions, except TERMINALS for MAINS supply: ⚡ (60417-2-IEC-5036)

c) Output TERMINALS provided for supply of other apparatus except MAINS supply shall be marked with the nominal output voltage and frequency, and, in addition, the maximum output current if with the most unfavourable load higher temperature rises than allowed in table 2 can occur, or power, unless the TERMINALS are marked with the type references of the apparatus which are permitted to be connected. When intended to be installed or interconnected in the field by a SKILLED PERSON, the Class of wiring shall be marked adjacent to the TERMINALS.

Socket-outlets providing MAINS power to other apparatus shall be marked with the power or current which may be drawn.

If there is only one TERMINAL provided for supply of other apparatus, the marking may be put on the apparatus at any place, taking into account the first paragraphs of clause 5.

d) Speaker TERMINALS on apparatus, other than PORTABLE APPARATUS, that is not provided with speakers and associated wiring shall be provided with a marking adjacent to the TERMINALS as identified below:

– “Class 1 Wiring” for TERMINALS with a measured open-circuit voltage exceeding 300 V rms when delivering NON-CLIPPED OUTPUT POWER, OR

– “Class 3 Wiring” for TERMINALS with a measured open-circuit voltage exceeding 120 V rms but not exceeding 300 V rms when delivering NON-CLIPPED OUTPUT POWER, OR

– “Class 2 Wiring” for all other terminals provided the audio output power exceeds 10 W under normal operating conditions or the apparatus is intended to be installed or interconnected in the field by a SKILLED PERSON

The operation manual shall discuss the risks involved, precautions to be taken as well as the reason for them, and instructions as to the proper connecting and insulating techniques to be used when connecting a speaker.

*Compliance is checked by inspection.*

**5.3 DU** When an apparatus is provided with safety related graphical symbols, the instructions shall include an illustration of the graphical symbols and an explanation of their meaning. Those symbols that are visible only after removal of a servicing cover by a SKILLED PERSON are only required to be explained in the service instructions. Explanations of required symbols in the operating manual shall precede any operating instructions.

Where in a manufacturer's service documentation, for example in circuit diagrams or lists of components, a symbol is used to indicate that a specific component shall be replaced only by the component specified in that documentation for safety reasons, the following symbol shall be used: ⚠ (ISO 7000-0434).

This symbol may also be put adjacent to the relevant component.

This symbol shall not be placed on components.

*Compliance is checked by inspection.*

#### 5.4 DU Instructions

When Information with regard to safety is required according to this standard. This information shall be given in a separate booklet or sheet or in an instruction for installation or use and supplied with the apparatus. These instructions shall be entitled "Important Safety Instructions" or the equivalent. This information shall be given in a language acceptable to the country where the apparatus is intended to be used. When included as part of the instruction manual, it shall be located before any operating instructions.

The important safety instruction shall include where applicable, the following information and warnings.

- 1) Read these instructions.

No Text on This Page



- 2) Keep these instructions.
- 3) Heed all warnings.
- 4) Follow all instructions.
- 5) Do not use this apparatus near water.
- 6) Clean only with dry cloth.
- 7) Do not block any ventilation openings. Install in accordance with the manufacturer's instructions.
- 8) Do not install near any heat sources such as radiators, heat registers, stoves, or other apparatus (including amplifiers) that produce heat.
- 9) Do not defeat the safety purpose of the polarized or grounding-type plug. A polarized plug has two blades with one wider than the other. A grounding type plug has two blades and a third grounding prong. The wide blade or the third prong are provided for your safety. If the provided plug does not fit into your outlet, consult an electrician for replacement of the obsolete outlet.
- 10) Protect the power cord from being walked on or pinched particularly at plugs, convenience receptacles, and the point where they exit from the apparatus.
- 11) Only use attachments/accessories specified by the manufacturer.
- 12) Use only with the cart, stand, tripod, bracket, or table specified by the manufacturer, or sold with the apparatus. When a cart is used, use caution when moving the cart/apparatus combination to avoid injury from tip-over.
- 13) Unplug this apparatus during lightning storms or when unused for long periods of time.
- 14) Refer all servicing to qualified service personnel. Servicing is required when the apparatus has been damaged in any way, such as power-supply cord or plug is damaged, liquid has been spilled or objects have fallen into the apparatus, the apparatus has been exposed to rain or moisture, does not operate normally, or has been dropped.

The symbol in figure 17 shall be shown adjacent to the text of item 12 above.

NOTE 1 – Reference is made to ISO/IEC Guide 37 [12].

NOTE 2 – The following information with regard to safety which are recommended to included as far as applicable:

- ~~minimum distances around the apparatus for sufficient ventilation;~~
- ~~the ventilation should not be impeded by covering the ventilation openings with items, such as newspapers, table cloths, curtains, etc.;~~
- ~~no naked flame sources, such as lighted candles, should be placed on the apparatus;~~
- ~~attention should be drawn to the environmental aspects of battery disposal;~~
- ~~the use of apparatus in tropical and/or moderate climates.~~

**5.4.1 DU** In addition, the instructions shall include the following as far as applicable.

a) For MAINS powered apparatus and for apparatus producing internal voltages greater than 35 V (peak) a.c. or d.c., having no protection against splashing water according to annex A, the instructions for use shall state that the apparatus shall not be exposed to dripping or splashing and that no objects filled with liquids, such as vases, shall be placed on the apparatus. "WARNING" and the following or equivalent, "To reduce the risk of fire or electric shock, do not expose this apparatus to rain or moisture."

b) A warning that TERMINALS marked with the symbol according to 5.2 b) are HAZARDOUS LIVE and that the external wiring connected to these TERMINALS requires installation by an INSTRUCTED PERSON or the use of ready-made leads or cords.

c) If an apparatus is provided with a replaceable lithium battery, the following applies:

- if the battery is intended to be replaced by the USER, there shall be a warning close to the battery or in both the instructions for use and the service instructions;
- if the battery is not intended to be replaced by the USER, there shall be a warning close to the battery or in the service instructions.

This warning shall include the following or similar text:

#### CAUTION

Danger of explosion if battery is incorrectly replaced.

Replace only with the same or equivalent type.

d) Information as required according to 14.6.3.

*Compliance is checked by inspection.*

**5.4.2** If a PERMANENTLY CONNECTED APPARATUS is not provided with an ALL-POLE MAINS SWITCH according to 14.6.1, the instructions shall state that an ALL-POLE MAINS SWITCH with a contact separation of at least 3 mm in each pole shall be incorporated in the electrical installation of the building.

**5.4.3 DU** When apparatus operation and installation instructions contain instructions for use by service personnel, such instructions shall be separate in format from other instructions and preceded by the word "CAUTION" and the following or the equivalent. "These servicing instructions are for use by qualified service personnel only. To reduce the risk of electric shock do not perform any servicing other than that contained in the operating instructions unless you are qualified to do so."

## 6 Hazardous radiations

### 6.1 DR Ionizing radiation

Apparatus including a potential source of ionizing radiation shall be so constructed that personal protection against ionizing radiation is provided under normal operating conditions and under fault conditions.

Compliance is checked by measurement under the following conditions: in accordance with the requirements in the United States Code of Federal Regulations, Title 21, Chapter 1, Subchapter J, Sections 1010.2, 1010.3, and 1020.10 by measuring the radiation produced by the apparatus employing a design center chassis.

*In addition to the normal operating conditions, all controls adjustable from the outside BY HAND, by any object such as a tool or a coin, and those internal adjustments or pre-sets which are not locked in a reliable manner, are adjusted so as to give maximum radiation whilst maintaining an intelligible picture for 1 h, at the end of which the measurement is made.*

NOTE 1— Soldered joints and paint lockings are examples of adequate locking.

*The exposure rate at any point outside the apparatus is determined by means of a radiation monitor with an effective area of 10 cm<sup>2</sup>, at a distance of 5 cm from the outer surface of the apparatus.*

*Moreover, the measurement shall be made under fault conditions causing an increase of the high-voltage, provided an intelligible picture is maintained for 1 h, at the end of which the measurement is made.*

*The exposure rate shall not exceed 36 pA/kg (0.5 mR/h).*

NOTE 2— The value is according to ICRP 15, clause 289 [16].

*A picture is considered to be intelligible if the following conditions are met:*

- a scanning amplitude of at least 70% of the usable screen width;*
- a minimum luminance of 50 cd/m<sup>2</sup> with locked blank raster provided by a test generator;*
- a horizontal resolution corresponding to at least 1.5 MHz in the centre, with a similar vertical degradation;*
- not more than one flash-over per 5 min.*

## 6.2 DR Laser radiation

An apparatus containing a LASER SYSTEM shall be so constructed that personal protection against laser radiation is provided under normal operating conditions and under fault conditions.

An apparatus containing a LASER SYSTEM is exempt from all further requirements of this subclause if:

- classification by the manufacturer according to IEC 60825-1, clauses 3, 8 and 9 shows that the approachable emission level does not exceed class 1 under all conditions of operation, maintenance, service and failure, and*
- it does not contain an embedded LASER according to IEC 60825-1.*

NOTE 1— Information about the measuring equipment is given in IEC 61040 [8].

NOTE 2— The term "approachable emission level" denotes "ACCESSIBLE EMISSION LEVEL (AEL)" in the sense of IEC 60825-1.

Apparatus shall be classified and labelled in accordance with the approachable emission level measured under fault conditions, except that for apparatus not exceeding class 1, IEC 60825-1, clause 5 does not apply. Code of Federal Regulations, Title 21, Chapter 1, Subchapter J, Sections 1010.2, 1010.3, 1040.10, and 1040.11.

*All controls adjustable from the outside BY HAND or any object such as a tool or a coin, and those internal adjustments or pre-sets which are not locked in a reliable manner, are adjusted so as to give maximum radiation.*

NOTE 3— Soldered joints and paint locking are examples of adequate locking.

The laser radiation emitted by redirection as mentioned in IEC 60825-1, 3.32 b), shall not be measured for a LASER SYSTEM OF CLASS 1.

*Compliance is met by satisfying the relevant requirements as specified in IEC 60825-1 with the following modifications and additions:*

#### **6.2.1—DR**

a) The apparatus shall meet under normal operating conditions, the approachable emission limits of class 1 as specified in IEC 60825-1, table 1. Time basis of the classification is 100 s.

*Compliance is checked by performing the relevant measurements as specified in IEC 60825-1, 8.2.*

b) If the apparatus incorporates a LASER SYSTEM which meets, under normal operating conditions, the approachable emission limits of class 1, the requirements mentioned under c) and d) do not apply.

c) Adequate measures shall be taken to prevent the opening of any cover BY HAND giving access to laser radiation in excess of class 1 limits.

*Compliance is checked by inspection and measurement.*

d) Where safety is dependent on the proper functioning of a mechanical SAFETY INTERLOCK, this interlock shall be fail-safe (in the failure mode the apparatus is rendered inoperative or non hazardous), or shall withstand a switching test of 50,000 cycles of operation with current and voltage applied as under normal operating conditions.

*Compliance is checked by inspection or test.*

#### **6.2.2—DR**

a) When the apparatus is operated under fault conditions as specified in 4.3, the approachable emission level from the apparatus shall be not higher than class 3A outside the wavelength range of 400 nm to 700 nm and not higher than five times the limit for class 1 within the wavelength range of 400 nm to 700 nm.

NOTE— The class 3A limits are as specified in IEC 60825-1, table 3.

*Compliance is checked by performing the relevant measurements as specified in IEC 60825-1, 8.2.*

~~b) If the apparatus incorporates a LASER SYSTEM which meets, under fault conditions, the approachable emission limits given in 6.2.2 a), the requirements mentioned under c) and d) do not apply.~~

~~c) Adequate measures shall be taken to prevent the opening of any cover BY HAND giving access to laser radiation in excess of the limits given in 6.2.2 a).~~

~~*Compliance is checked by inspection and measurement.*~~

~~d) Where safety is dependent on the proper functioning of a mechanical SAFETY INTERLOCK, this interlock shall be fail-safe (in the failure mode the apparatus is rendered inoperative or non hazardous), or shall withstand a switching test of 50,000 cycles of operation with current and voltage applied as under normal operating conditions.~~

~~*Compliance is checked by inspection or test.*~~

## 7 Heating under normal operating conditions

### 7.1 DU General

During intended use, no part of the apparatus shall attain an excessive temperature.

*Compliance is checked by measuring the temperature rises under normal operating conditions when a steady state has been attained.*

NOTE 1 – In general, a steady state is assumed to be attained after 4 h of operation

*Temperature rises are determined:*

*– in the case of winding wires, by the change in resistance method or any other method giving the average temperature of the winding wires;*

NOTE 2 – Care should be taken to ensure that during the measurement of the resistance of winding wires, the influence of circuits or loads connected to these winding wires is negligible.

*– in other cases, by any suitable method.*

Temperature rises shall not exceed the values specified in 7.1.1 to 7.1.5 inclusive.

Protective circuits and devices, except redundant protection circuits, THERMAL CUT-OUTS with automatic reset and PTC-S THERMISTORS, affecting the safety of the apparatus shall not operate during the test.

#### 7.1.1 ACCESSIBLE parts

The temperature rise of ACCESSIBLE parts shall not exceed the values given in table 2, item a), "normal operating conditions".

### 7.1.2 Parts, other than windings, providing electrical insulation

The temperature rise of insulating parts, other than windings, providing BASIC, SUPPLEMENTARY, OR REINFORCED INSULATION, and of insulating parts, the failure of which would cause an infringement of the requirements of 9.1.1 or a fire hazard, shall not exceed the values given in table 2, item b), "normal operating conditions", taking into account condition 4 of table 2.

*If an insulating part is used to establish a CLEARANCE or to contribute to a CREEPAGE DISTANCE and its permissible temperature rise is exceeded, then the relevant area of the insulating part is disregarded when compliance with clauses 8 and 11 is checked.*

### 7.1.3 Parts acting as a support or a mechanical barrier

The temperature rise of parts, a mechanical failure of which would cause an infringement of the requirements of 9.1.1, shall not exceed the value given in table 2, item c), "normal operating conditions".

### 7.1.4 Windings

The temperature rise of windings comprising insulation providing protection against electric shock or fire hazard shall not exceed the values given in table 2, items b) and d), "normal operating conditions".

*If an insulating part is used to establish a CLEARANCE or to contribute to a CREEPAGE DISTANCE and its permissible temperature rise is exceeded, then the relevant area of the insulating part is disregarded when compliance with clauses 8 and 11 is checked.*

NOTE – If the insulation is incorporated in a winding in such a way that its temperature rise cannot be measured directly, the temperature is assumed to be the same as that of the winding wire.

### 7.1.5 Parts not subject to a limit under 7.1.1 to 7.1.4 inclusive

According to the nature of the material, the temperature rise of the part shall not exceed the values given in table 2, item e), "normal operating conditions".

**Table 2 DC DU – Permissible temperature rise of parts of the apparatus**

Parts of the apparatus	Normal operating conditions	Fault conditions
	K	K
a) <i>ACCESSIBLE PARTS</i>		
Knobs, handles, etc. if:		
– metallic	30	65
– non-metallic (note 3)	50	65
Enclosures if:		
– metallic (note 2)	40	65
– non-metallic (notes 2 and 3)	60	65
b) <i>Parts providing electrical insulation (note 4)</i>		
Supply cords and wiring insulation with		
– polyvinyl chloride or synthetic rubber		
– not under mechanical stress	60	100

Table 2 DC DU – Permissible temperature rise of parts of the apparatus Continued on Next Page

**Table 2 DC DU – Permissible temperature rise of parts of the apparatus Continued**

Parts of the apparatus	Normal operating conditions	Fault conditions
	K	K
– under mechanical stress	45	100
– natural rubber	45	100
Other insulations of:		
– thermoplastic materials (note 5)	(note 6)	(note 6)
– non-impregnated paper	55	70
– non-impregnated cardboard	60	80
– impregnated cotton, silk, paper and textile	70	90
– laminates based on cellulose or textile, bonded with		
– phenol-formaldehyde, melamine-formaldehyde, phenol-furfural or polyester	85	110
– epoxy	120	150
– mouldings of		
– phenol-formaldehyde or phenol-furfural, melamine and melamine phenolic compounds with		
–cellulose fillers	100	130
–mineral fillers	110	150
– thermosetting polyester with mineral fillers	95	150
– alkyd with mineral fillers	95	150
– composite materials of		
– polyester with glass-fibre reinforcement	95	150
– epoxy with glass-fibre reinforcement	100	150
– silicone rubber	145	190
c) <i>Parts acting as a support or a mechanical barrier including the inside of enclosures (note 4)</i>		
Wood and WOOD-BASED MATERIALS	60	90
Thermoplastic materials (note 5)	(note 6)	(note 6)
d) <u>Coil winding wires and insulation systems</u> (note 4)		
– insulated with		
– non-impregnated silk, cotton, etc. <u>Class 105 (A) insulation system</u>	55 75	75 110
– impregnated silk, cotton, etc. <u>Class 120 (E) insulation system</u>	70 90	100 125
– oleoresinous materials <u>Class 130 (B) insulation system</u>	70 95	135 130
– polyvinyl-formaldehyde or polyurethane resins <u>Class 155 (F) insulation system</u>	85 115	150
– polyester resins <u>Class 180 (H) insulation system</u>	120 135	155 170
– polyesterimide resins	145	180
e) <i>Other parts</i>		
These temperature rises apply to parts not covered by items a), b), c) and d):		
Parts of wood and WOOD-BASED MATERIAL	60	140
Lithium batteries	40	50
All other parts, except resistors and parts of metal, glass, ceramic.	200	300
NOTE 1 – General conditions applicable to table 2: For tropical climates, permissible temperature rises of 10 K less than those specified in this table are required. The values of the temperature rises are based on a maximum ambient temperature of 35°C for moderate climates and of 45°C for tropical climates. <u>Materials rated in accordance with UL 746B, for higher operating temperatures, may be used at the higher operating temperature.</u>		

Table 2 DC DU – Permissible temperature rise of parts of the apparatus Continued

Parts of the apparatus	Normal operating conditions K	Fault conditions K
<p>NOTE 2 – For areas having no dimension exceeding 5 cm and for heat sinks or metallic parts directly covering heat sinks, without a dimensional restriction, which are not likely to be touched during intended use, temperature rises up to 65 K are allowed under normal operating conditions.</p> <p>For outside parts of metal which are covered with plastic material, the thickness of which is at least 0.3 mm, a temperature rise which corresponds to the permissible temperature rise of the insulating material is allowed.</p> <p>NOTE 3 – If these temperature rises are higher than those allowed by the class of the relevant insulating material, the nature of the material is the governing factor.</p> <p>NOTE 4 – For the purpose of this standard, the permissible temperature rises are based on service experience in relation to the thermal stability of the materials. The materials quoted are examples. For materials for which higher temperature limits are claimed, and for materials other than those listed, the maximum temperatures should not exceed those which have been proved to be satisfactory, for example in accordance with IEC 60085.</p> <p>NOTE 5 – Natural rubber and synthetic rubbers are not considered as being thermoplastic materials.</p> <p>NOTE 6 – Due to their wide variety, it is not possible to specify permissible temperature rises for thermoplastic materials. While the matter is under consideration, the following method shall be used:</p> <p>a) a softening temperature of the material is determined on a separate specimen, under the conditions specified in ISO 306 with a heating rate of 50 K/h and modified as follows:</p> <ul style="list-style-type: none"> <li>– the depth of penetration is 0.1 mm;</li> <li>– the total thrust of 10 N is applied before the dial gauge is set to zero or its initial reading noted.</li> </ul> <p>b) the temperature limits to be considered for determining the temperature rises are:</p> <ul style="list-style-type: none"> <li>– under normal operating conditions, a temperature of 10 K below the softening temperature as obtained under item a);</li> <li>– under fault conditions, the softening temperature itself.</li> </ul> <p>If the required softening temperature exceeds 120°C, note 3 shall be taken into account.</p>		

## 7.2 DC Heat resistance of insulating material

A thermoplastic insulating material supporting parts CONDUCTIVELY CONNECTED TO THE MAINS shall be resistant to heat if, during intended use, these parts carry a steady-state current exceeding 0.2 A and can generate substantial heat due to imperfect contact.

*Compliance is checked by inspection of the rating as specified in note 1 of table 2, or by subjecting the insulating material to the test specified in table 2 under item a) of note 6.*

The softening temperature or rating of the insulating material shall be at least 150°C.

In those cases where two groups of conductors, each supported by insulating parts, can be rigidly connected or joined together, for example by plug and socket, only one of the insulating parts need meet the test. Where one of the insulating parts is fixed in the apparatus, this part shall meet the test.

NOTE 1 – Examples of parts which can generate substantial heat during intended use are contacts of switches and of voltage setting devices, screw TERMINALS and fuse holders.

NOTE 2 – This test need not be performed on parts which are in accordance with a relevant IEC or UL standard.



## 8 Constructional requirements with regard to the protection against electric shock

**8.1 DU** Conductive parts, covered only by lacquer, solvent-based enamel, ordinary paper, untreated textile, oxide films or beads are considered to be bare.

A metal part that is not inherently resistant to corrosion shall be protected against corrosion when corrosion of that part is capable of contributing to or resulting in a risk of fire, shock, or injury to persons.

*Compliance is checked by inspection.*

**8.2** The apparatus shall be designed and constructed such that operation BY HAND, like

- changing the setting for the voltage or nature of supply;
- replacing fuse-links and indicator lights;
- handling of drawers etc;

does not involve a risk of electric shock.

*Compliance is checked by application of the tests of 9.1.1.*

**8.3** The insulation of HAZARDOUS LIVE parts shall not be provided by hygroscopic materials.

*Compliance is checked by inspection and, in case of doubt, by the following test.*

*A specimen of the material, as specified in IEC 60167, clause 9, is subjected to a temperature of (40 ±2)°C, and a relative humidity of 90% to 95%, the conditioning period being:*

- 7 days (168 h) for apparatus to be used under tropical conditions;
- 4 days (96 h) for other apparatus.

*Within 1 min after this preconditioning, the specimen shall withstand the tests of 10.3 without the humidity treatment according to 10.2.*

**8.4** The apparatus shall be so constructed that there is no risk of an electric shock from ACCESSIBLE parts or from those parts rendered ACCESSIBLE following the removal BY HAND of a cover.

This requirement applies also to internal parts of battery compartments which become ACCESSIBLE by the removal of a cover when replacing the batteries.

This requirement does not apply to battery compartments inside the apparatus, where the replacement of their batteries by the USER is not intended, for example batteries for memories.

*Compliance is met by satisfying the requirements of 8.5 or 8.6.*

NOTE – Inaccessible contacts of TERMINALS are regarded as ACCESSIBLE parts, unless marked with the symbol according to 5.2 b) or intended to connect the apparatus to the MAINS or to provide MAINS power to other apparatus.

**8.5** For CLASS I apparatus, the ACCESSIBLE conductive parts, except for those parts of the apparatus which have DOUBLE OR REINFORCED INSULATION (CLASS II construction), shall be separated from HAZARDOUS LIVE parts by BASIC INSULATION meeting the insulation requirements as specified in clause 10 and the requirements for CLEARANCES and CREEPAGE DISTANCES as specified in clause 13.

This requirement does not apply to insulations whose short-circuiting does not cause any electric shock hazard.

NOTE 1 – For example, if one end of a secondary winding of a SEPARATING TRANSFORMER is connected to an ACCESSIBLE conductive part, the other end need not meet any special insulation requirement with regard to the same ACCESSIBLE conductive part.

A resistor bridging BASIC INSULATION shall comply with the requirements as specified in 14.1 a).

NOTE 2 – Parts of the apparatus which have DOUBLE OR REINFORCED INSULATION (CLASS II construction) may be bridged by a resistor or in compliance with the requirements as specified in 14.1 a).

A capacitor or RC-unit bridging BASIC INSULATION between a HAZARDOUS LIVE part and an ACCESSIBLE conductive part connected to the PROTECTIVE EARTH TERMINAL, shall comply with the requirements of 14.2.1 a).

Such resistors, capacitors or RC-units shall be positioned inside the enclosure of the apparatus.

CLASS I apparatus shall be provided with a PROTECTIVE EARTH TERMINAL or contact to which the protective earth contacts of socket-outlets, if any, and ACCESSIBLE conductive parts shall be reliably connected. Such connection is not necessary for those ACCESSIBLE conductive parts which are insulated from HAZARDOUS LIVE parts by DOUBLE OR REINFORCED INSULATION (CLASS II construction) or those which are protected from becoming HAZARDOUS LIVE by a conductive part reliably connected to the PROTECTIVE EARTH TERMINAL.

NOTE 3 – Examples of such a conductive part are a metal screen in a transformer between the primary and the secondary windings, a metal chassis, etc.

*Compliance is checked by inspection.*

**8.6** For CLASS II apparatus, the ACCESSIBLE parts shall be separated from HAZARDOUS LIVE parts either by DOUBLE INSULATION specified under item a) or by REINFORCED INSULATION specified under item b).

This requirement does not apply to insulations whose short-circuiting does not cause any electric shock hazard.

NOTE 1 – For example, if one end of a secondary winding of a SEPARATING TRANSFORMER is connected to an ACCESSIBLE conductive part, the other end need not meet any special insulation requirement with regard to the same ACCESSIBLE conductive part.

A component complying with the requirements of 14.1 a) or 14.3 except components according to 14.3.4.3, may bridge BASIC, SUPPLEMENTARY, DOUBLE OR REINFORCED INSULATION.

Components according 14.3.4.3 may bridge BASIC INSULATION only.

BASIC and SUPPLEMENTARY INSULATIONS may each be bridged by a capacitor or RC-unit, having the same rated values, complying with the requirements of 14.2.1 a).

DOUBLE OR REINFORCED INSULATION may be bridged by two capacitors or RC-units in series, having the same rated values, each complying with the requirements of 14.2.1 a).

Alternatively DOUBLE OR REINFORCED INSULATION may be bridged by a single capacitor or RC-unit complying with the requirements of 14.2.1 b).

NOTE 2 – For external insulation, bridging DOUBLE OR REINFORCED INSULATION, also see 8.8.

Such resistors, capacitors or RC-units shall be positioned inside the enclosure of the apparatus.

*Compliance is checked by inspection.*

a) If ACCESSIBLE parts are separated from HAZARDOUS LIVE parts by BASIC and SUPPLEMENTARY INSULATION, the following shall apply:

Each of these insulations shall comply with the insulation requirements as specified in clause 10 and with the requirements for CLEARANCES and CREEPAGE DISTANCES specified in clause 13.

Enclosures of wood not complying with the requirements of 8.3 are permitted as SUPPLEMENTARY INSULATION if they withstand the dielectric strength test of 10.3.

*Compliance is checked by inspection and/or measurement.*

b) If ACCESSIBLE parts are separated from HAZARDOUS LIVE parts by REINFORCED INSULATION the following shall apply:

The insulation shall comply with the insulation requirements specified in clause 10. Moreover, it shall comply with the requirements for CLEARANCES and CREEPAGE DISTANCES specified in clause 13.

NOTE 3 – An example of assessment of REINFORCED INSULATION is given in figure 2.

*Compliance is checked by inspection and/or measurement.*

**8.7** For voltages above 35 V (peak) up to and including 71 V (peak) a.c. or above 60 V d.c. up to and including 120 V d.c. (RIPPLE FREE), measured at the RATED SUPPLY VOLTAGE under normal operating conditions and under fault conditions, in deviation from 8.5 or 8.6 respectively, BASIC INSULATION meeting the requirements of clause 10 and clause 13 is sufficient, between circuits with the voltages above and ACCESSIBLE parts or parts connected to ACCESSIBLE conductive parts.

Circuits with the voltages above shall be separated from HAZARDOUS LIVE parts with higher voltages by DOUBLE OR REINFORCED INSULATION according to 8.6 or by an ISOLATING TRANSFORMER according to 14.3.2 (CLASS II construction) or by a conductive part connected to the PROTECTIVE EARTH TERMINAL according to 8.5 or by a transformer according to 14.3.3 (CLASS I construction).

*Compliance is checked by inspection.*

**8.8** BASIC, SUPPLEMENTARY and REINFORCED INSULATION shall each withstand the dielectric strength test as specified in 10.3.

For DOUBLE INSULATION either the BASIC or the SUPPLEMENTARY INSULATION shall have a thickness of at least 0.4 mm.

REINFORCED INSULATION shall have a minimum thickness of 0.4 mm when not subject to any mechanical stress which, at the temperatures during normal operating conditions and under fault conditions, would be likely to lead to deformation or deterioration of the insulating material.

NOTE – Under mechanical stress conditions the thickness may have to be increased to comply with the insulation requirements as specified in clause 10 and the mechanical strength requirements as specified in clause 12.

The above requirements are not applicable to insulation in thin sheet materials irrespective of their thickness provided that:

- it is used within the enclosure of the apparatus, and
- BASIC OR SUPPLEMENTARY INSULATION comprises at least two layers of material, each of which will pass the dielectric strength test specified in 10.3 for BASIC OR SUPPLEMENTARY INSULATION, or
- BASIC OR SUPPLEMENTARY INSULATION comprises three layers of material for which all combinations of two layers together pass the dielectric strength test specified in 10.3 for BASIC OR SUPPLEMENTARY INSULATION, OR
- REINFORCED INSULATION comprises at least two layers of material, each of which will pass the dielectric strength test specified in 10.3 for REINFORCED INSULATION, or
- REINFORCED INSULATION comprises three layers of insulation material for which all combinations of two layers together pass the dielectric strength test specified in 10.3 for REINFORCED INSULATION.

There is no requirement for all layers of insulation to be of the same insulating material.

*Compliance is checked by inspection and measurement.*

**8.9** The insulation of internal wiring between HAZARDOUS LIVE conductors in wires or cables and ACCESSIBLE parts, or between HAZARDOUS LIVE parts and conductors in wires or cables connected to ACCESSIBLE conductive parts, shall have a thickness of at least 0.4 mm if made of polyvinyl chloride. Other materials are allowed provided that they withstand the dielectric strength test specified in 10.3 and that their thickness ensures an equivalent mechanical strength, where the construction so requires.

NOTE – For example a polytetrafluoroethylene (PTFE) insulation having a thickness of at least 0.24 mm is considered to fulfil this requirement.

*Compliance is checked by inspection and measurement.*

**8.9.1** DC Slewing, tape, tubing, and wire insulation shall be suitable for the conditions of use, such as voltage and temperature, and comply with the requirements in UL 224, UL 510, and UL 1441 as applicable.

**8.10** In CLASS II apparatus DOUBLE INSULATION shall be provided between

- ACCESSIBLE parts and conductors in wires or cables CONDUCTIVELY CONNECTED TO THE MAINS and
- conductors in wires or cables connected to ACCESSIBLE conductive parts and parts CONDUCTIVELY CONNECTED TO THE MAINS.

Either the BASIC or the SUPPLEMENTARY INSULATION shall comply with the requirements of 8.9. The other insulation shall withstand the dielectric strength test specified in 10.3 for BASIC OR SUPPLEMENTARY INSULATION.

If DOUBLE INSULATION consists of two layers which cannot be tested separately, it shall withstand the dielectric strength test specified in 10.3 for REINFORCED INSULATION.

The test voltage of 10.3 is applied between the conductor and metal foil wrapped tightly around the insulation of the wire over a length of 10 cm.

In the case of insulating sleeves, the test voltage of 10.3 is applied between a tight-fitting metal rod inserted into the sleeve and a metal foil wrapped tightly around the sleeve over a length of 10 cm.

*Compliance is checked by inspection and measurement.*

**8.11** The construction of the apparatus shall be such that, should any wire become detached, the CLEARANCES and CREEPAGE DISTANCES are not reduced below the values specified in clause 13 by the natural movement of a detached wire. This requirement does not apply if there is no risk of a wire becoming detached.

NOTE 1 – It is assumed that not more than one connection will become detached at the same time.

*Compliance is checked by inspection and measurement.*

NOTE 2 – Examples of methods deemed to prevent a wire from becoming detached are:

- a) the conductor of the wire is anchored to the tag before soldering, unless breakage close to the soldering place is likely to occur as a result of vibration;
- b) wires are twisted together in a reliable manner;
- c) wires are fastened together reliably by cable ties, adhesive tapes with thermosetting adhesives according to IEC 60454, sleeves or the like;
- d) the conductor of the wire is inserted into a hole in a PRINTED BOARD before soldering, the hole having a diameter slightly greater than that of the conductor, unless breakage close to the PRINTED BOARD is likely to occur as a result of vibration;

e) the conductor of the wire and its insulation, if any, is securely wrapped around the termination by means of a special tool;

f) the conductor of the wire and its insulation, if any, are crimped to the termination by means of a special tool.

The methods under items a) up to and including f) apply to internal wires and the methods under items a) up to and including c) to external flexible cords.

*In case of doubt, the vibration test of 12.1.2 is carried out to verify compliance.*

**8.12** Conductors of internal wiring connecting MAINS socket-outlets incorporated in the apparatus to the MAINS TERMINALS either directly or via a MAINS switch shall comply with the cross-sectional area requirements of 16.2.

*Compliance is checked by inspection.*

**8.13** Windows, lenses, signal lamp covers, etc. shall be fastened by positive means if HAZARDOUS LIVE parts are rendered ACCESSIBLE by their absence.

NOTE – Friction only is not regarded as a positive means.

*Compliance is checked by inspection and, in case of doubt, by applying a force from the outside of 20 N for 10 s at the most unfavourable place and in the most unfavourable direction.*

**8.14** Covers which may be subjected to forces during intended use, for example covers supporting TERMINALS (see clause 15) shall be fastened by positive means if HAZARDOUS LIVE parts are rendered ACCESSIBLE by their absence.

NOTE – Friction only is not regarded as a positive means.

*Compliance is checked by inspection and, in case of doubt, by applying a force of 50 N for 10 s at the most unfavourable place and in the most unfavourable direction.*

*After the tests of 8.13 and 8.14, the apparatus shall show no damage in the sense of this standard; in particular no HAZARDOUS LIVE parts shall become ACCESSIBLE.*

**8.15** Internal wiring of the apparatus, damage to the insulation of which is liable to cause a hazard in the sense of this standard, shall

– be secured so as not to contact parts exceeding the permissible temperature rise for the insulation of the wires as specified in table 2 when a force of 2 N is applied to any part of the wiring or their surroundings, and

– be so constructed that there is no risk of damage to the insulation of the wires, for example sharp edges, moving parts or pinches, which may come into contact with other parts of the apparatus, when a force of 2 N is applied to any part of the wiring or their surroundings.

*Compliance is checked by inspection and measurement.*

**8.16** Apparatus designed to be supplied exclusively by a SUPPLY APPARATUS specified by the manufacturer of the apparatus, shall be so constructed that the SPECIAL SUPPLY APPARATUS cannot be replaced, without modification, by a SUPPLY APPARATUS FOR GENERAL USE

NOTE – The required non-interchangeability may be obtained for example by special connections.

*Compliance is checked by inspection.*

**8.17 DC** Printed wiring boards involved with the risk of electric shock shall comply with the requirements in UL 796.

## 9 Electric shock hazard under normal operating conditions

### 9.1 Testing on the outside

#### 9.1.1 DR DU General

9.1.1 revised June 23, 2000

HAZARDOUS LIVE parts shall not be ACCESSIBLE.

NOTE 1 – For interconnection with apparatus under the scope of other standards, circuits should comply with 9.1.1 and, depending upon the construction, with 8.5 or 8.6.

In addition, when not connected to another apparatus, inaccessible contacts of TERMINALS shall not be HAZARDOUS LIVE, with the following exceptions:

– contacts of signal output TERMINALS, if they have to be HAZARDOUS LIVE for functional reasons, provided the contacts are separated from the supply source as required according to clause 8 for ACCESSIBLE conductive parts.

NOTE 2 – Inaccessible input TERMINALS, for example of loudspeakers, are permitted to be HAZARDOUS LIVE when connected to such output TERMINALS.

NOTE 3 – For the marking of such output TERMINALS see 5.2 b)

– TERMINALS complying with 15.1.1 provided for connecting the apparatus to the MAINS, socket-outlets and contacts of connecting blocks for providing power to other apparatus.

*In order to verify that a part or a contact of a TERMINAL is not HAZARDOUS LIVE, the following measurements are carried out between any two parts or contacts, then between any part or contact and either pole of the supply source used during the test. Discharges shall be measured to the TERMINAL provided for connecting the apparatus to the supply source, immediately after the interruption of the supply.*

NOTE 4 – For discharges between the poles of the MAINS plug, see 9.1.6.

*The part or contact of a TERMINAL is not HAZARDOUS LIVE if:*

*a) the open-circuit voltage does not exceed 120 V rms for audio output TERMINALS of apparatus used for the amplification of audio signals, when tested in accordance with 4.2.4 under the NON-CLIPPED OUTPUT POWER condition.*

*a b) the open-circuit voltage does not exceed 35 V (peak) a.c. or 60 V d.c.,*

*or, if a b) is not met,*

*b c) the measurement of the TOUCH-CURRENT shall be carried out in accordance with IEC 60990 the American National Standard for Leakage Current for Appliances, ANSI C101, with the measuring network described in annex D of this standard.*

The TOUCH-CURRENT ~~expressed as voltages  $U_1$  and  $U_2$ , does~~ shall not exceed the following values:

– 1.5 MIU to earth for a Class 1 cord connected commercial AUDIO AMPLIFIER designed solely for rack mounting or STATIONARY use

– for a.c.:  $U_1 = 35 \text{ V (peak)}$  and  $U_2 = 0.35 \text{ V (peak)}$  0.75 MIU for an apparatus that is permanently connected electrically or a three-wire (including grounding conductor) cord- and plug-connected apparatus intended to be

- 1) fastened in place or
- 2) located in a dedicated position;

– for d.c.:  $U_1 = 1.0 \text{ V (dev)}$  0.5 MIU for all other apparatus

NOTE 5 – The limit values of  $U_2 = 0.35 \text{ V (peak)}$  for a.c. and  $U_1 = 1.0 \text{ V}$  for d.c. correspond to the values 0.7 mA (peak) a.c. and 2.0 mA d.c.

The limit value  $U_1 = 35 \text{ V (peak)}$  for a.c. corresponds to the value 70 mA (peak) a.c. for frequencies greater than 100 kHz.

and moreover

*e d) the discharge does not exceed  $45 \mu\text{C}$  for stored voltages between 60 V and 15 kV, or*

*d e) the energy of discharge does not exceed 350 mJ for stored voltages exceeding 15 kV.*

NOTE 6 – It is recommended that for apparatus intended to be used in tropical climates, the values given in a b) and b c) above, be halved.

NOTE 7 – To avoid unnecessarily high TOUCH CURRENTS when several apparatus are interconnected, it is recommended that the individual TOUCH CURRENT values are not higher than needed for functional reasons.

*In order to determine whether a HAZARDOUS LIVE part is ACCESSIBLE, the jointed test finger according to test probe B of IEC 61032 figure 14, is pushed against the enclosure or inserted through any openings of the enclosure, including openings in the bottom, without appreciable force.*

*Through openings, the test finger is applied to any depth that the finger will permit and is rotated or angled before, during and after insertion to any position. If the opening does not allow the entry of the finger, the force on the finger in the straight position is increased to  $20 \text{ N} \pm 2 \text{ N}$  and the test repeated with the finger in angled position.*

*Conductive parts, covered only by lacquer, solvent-based enamel, ordinary paper, untreated textile, oxide films or beads are considered to be bare.*

*For CLASS II constructions, the test probe 13 of IEC 61032 shall not touch HAZARDOUS LIVE parts when applied with a force of  $3 \text{ N} \pm 0.3 \text{ N}$  in every possible position.*

*The test probe is not applied to socket-outlets, connectors providing MAINS power, fuse holders and the like.*



NOTE 8 – For indication of electrical contact a voltage of not less than 40 V and not more than 50 V in series with a suitable lamp may be used.

No Text on This Page

The above requirements to determine whether a HAZARDOUS LIVE part is ACCESSIBLE apply only to HAZARDOUS LIVE voltages not exceeding 1000 V a.c. or 1500 V d.c. For higher voltages, there shall be a CLEARANCE between the part at HAZARDOUS LIVE voltage and the test finger or the test pin as specified in 13.1.1 for BASIC INSULATION (see figure 3).

### 9.1.2 Shafts of operating knobs, handles, levers and the like

Shafts of operating knobs, handles, levers and the like shall not be HAZARDOUS LIVE.

*Compliance is checked by inspection, in case of doubt by measurement according to 9.1.1.*

### 9.1.3 Openings of the enclosure

The apparatus shall be so designed that suspended foreign bodies cannot become HAZARDOUS LIVE, when introduced through ventilation or other holes.

*Compliance is checked by applying to the holes a metal test pin having a diameter of 4 mm and a length of 100 mm. The test pin is suspended freely from one end, the penetration is limited to the length of the test pin.*

*The test pin shall not become HAZARDOUS LIVE.*

### 9.1.4 TERMINALS

The use of a single-pole plug or a bare wire to make connection with a contact of a TERMINAL for earth or antenna or for audio, video or associated signals, shall not involve the risk of an electric shock.

The test is not applied to TERMINALS marked with the symbol of 5.2 b).

NOTE – See also 15.1.2.

*Compliance is checked by the following tests:*

*Within 25 mm measured from each contact of the TERMINAL, a test pin according to IEC 61032, test probe 16, is applied in every possible position, in case of doubt with a force of  $10\text{ N} \pm 1\text{ N}$ .*

*Each contact is tested with a straight test probe according to IEC 61032, test probe D, in case of doubt with a force of  $1\text{ N} \pm 0.1\text{ N}$ .*

*The test probes shall not become HAZARDOUS LIVE.*

### 9.1.5 Pre-set controls

If a hole giving access to pre-set controls is marked as such on the enclosure or in the instruction for use, and the setting of this control requires a screwdriver or other tool, the adjustment of the control shall not involve the risk of an electric shock.

*Compliance is checked by applying to the opening a test probe according to IEC 61032, test probe C.*

*The test probe is applied in every possible position, in case of doubt with a force of  $10\text{ N} \pm 1\text{ N}$ .*

*The test probe shall not become HAZARDOUS LIVE.*

### 9.1.6 DE Withdrawal of MAINS plug

Apparatus intended to be connected to the MAINS by means of a MAINS plug shall be so designed that there is no risk of an electric shock from stored charge on capacitors, when touching the pins or contacts of the plug after its withdrawal from the socket-outlet.

NOTE – For the purpose of this subclause, male interconnection couplers and male appliance couplers are regarded as MAINS plugs.

*Compliance is checked by measurement according to 9.1.1 a b) or c d) or by calculation.*

*The MAINS switch, if any, is in the off-position, unless it is more unfavourable in the on-position.*

*Two seconds after withdrawal of the MAINS plug, the pins or contacts of the plug shall not be HAZARDOUS LIVE.*

*The test may be repeated up to 10 times to obtain the most unfavourable situation.*

*If the nominal capacitance across the MAINS poles does not exceed 0.1  $\mu$ F, no test is conducted.*

### 9.1.7 Resistance to external forces

The enclosure of the apparatus shall be sufficiently resistant to external forces.

*Compliance is checked by the following tests:*

*a) by means of a rigid test finger according to IEC 61032, test probe 11, a force of 50 N  $\pm$  5 N, directed inwards, is applied for 10 s to different points of the enclosure including openings and textile coverings.*

*The force shall be so exerted by the tip of the test finger as to avoid wedge or lever action.*

*During the test the enclosure shall not become HAZARDOUS LIVE, HAZARDOUS LIVE parts shall not become ACCESSIBLE, textile coverings shall not touch HAZARDOUS LIVE parts;*

*b) by means of a test hook as shown in figure 4, a force of 20 N  $\pm$  2 N, directed outwards, is applied for 10 s at all points where this is possible.*

*During the test, HAZARDOUS LIVE parts shall not become ACCESSIBLE;*

*c) external conductive enclosures and conductive parts of an external enclosure shall be subjected for 5 s to a steady force of (250  $\pm$  10) N for floorstanding apparatus or (100  $\pm$  10) N for other apparatus, applied to the enclosure or to a part of the enclosure fitted to the apparatus, by means of a suitable test tool providing contact over a circular plane surface 30 mm in diameter.*

NOTE 1 – Contents of TERMINALS are not considered to be a conductive part of the external enclosure.

*After the tests, the apparatus shall show no damage in the sense of this standard.*

NOTE 2 – The apparatus need not to be connected to the supply source during the tests.

## 9.2 Removal of protective covers

A part which becomes ACCESSIBLE by the removal of a cover BY HAND shall not be HAZARDOUS LIVE.

This requirement applies also to internal parts of battery compartments which become ACCESSIBLE by the removal of a cover either BY HAND or with the use of a tool, coin or other object, when replacing the batteries. An exception is made in the case of batteries which are not intended to be replaced by the USER, for example batteries for memories.

*Compliance is checked by application of the tests of 9.1.1, except that the measurements are made 2 s after removal of the cover.*

NOTE – Any part removal BY HAND of a voltage setting device is considered to be a protective cover.

## 10 Insulation requirements

### 10.1 Surge test

Insulation between ACCESSIBLE parts or parts connected to them and HAZARDOUS LIVE parts, shall be able to withstand surges due to transients, caused for example by thunderstorms and entering the apparatus through the antenna TERMINAL.

*Compliance is checked by the following test:*

*The insulation between*

– TERMINALS for the connection of antenna and MAINS supply TERMINALS,

*and between*

– MAINS supply TERMINALS and any other TERMINAL in case of apparatus which may be interconnected to other apparatus with antenna TERMINALS,

*is subjected to 50 discharges at a maximum rate of 12/min, from a 1 nF capacitor charged to 10 kV in a test circuit, as shown in figure 5A.*

NOTE – During this test, the apparatus should not be energized.

*After the test, the tested insulation shall comply with the requirements of 10.3.*

### 10.2 Humidity treatment

The safety of the apparatus shall not be impaired by humidity conditions which may occur in the intended use.

*Compliance is checked by the humidity treatment described in this subclause, followed immediately by the tests of 10.3.*

*Cable entries, if any, are left open. If knock-outs are provided, they are opened.*

*Electrical components, covers and other parts which can be removed BY HAND are removed and subjected, if necessary, to the humidity treatment with the main part.*

*The humidity treatment is carried out in a humidity chamber containing air with a relative humidity of 93 (+2, -3)%.*

*The temperature of the air, at all places where the apparatus can be located, is maintained at 30 (+0, -2)°C.*

*Apparatus intended to be used in tropical climates are subjected to a temperature of (40 ±2)°C and a relative humidity of 93 (+2, -3)%.*

*Before being placed in the chamber, the apparatus is brought to a temperature between the specified temperature and a 4 K higher temperature.*

*The apparatus is kept in the chamber for*

- 5 days (120 h) for apparatus intended to be used in tropical climates,*
- 2 days (48 h) for other apparatus.*

NOTE 1 – In most cases, the apparatus may be brought to the specified temperature by keeping it at this temperature for at least 4 h before the humidity treatment.

NOTE 2 – Some methods of achieving the specified relative humidities are described in IEC 60260 [5].

NOTE 3 – The air in the chamber should be stirred and the chamber should be so designed that mist or condensed water will not precipitate on the apparatus.

NOTE 4 – During this test, the apparatus should not be energized.

*After this treatment, the apparatus shall show no damage in the sense of this standard.*

### **10.3 Insulation resistance and dielectric strength**

**10.3.1** The insulation of the insulating materials shall be adequate.

*Compliance is checked in accordance with 10.3.2, and, unless otherwise stated, immediately after the humidity treatment according to 10.2.*

NOTE – In order to facilitate dielectric strength testing, components and sub-assemblies may be tested separately.

**10.3.2** *The insulations listed in table 3 shall be tested:*

- for insulation resistance with 500 V d.c.; and*
- for dielectric strength as follows:*
  - insulations stressed with d.c. voltage (RIPPLE FREE) are tested with a d.c. voltage;*
  - insulations stressed with a.c. voltage are tested with an a.c. voltage at MAINS frequency.*

*However, where corona, ionization, charge affects or the like may occur, a d.c. test voltage is recommended.*

NOTE 1 – Where there are capacitors across the insulation under test, it is recommended that d.c. test voltages are used.

*Test voltages shall be as specified in table 3 for the appropriate grade of insulation (BASIC, SUPPLEMENTARY OR REINFORCED INSULATION) and for the OPERATING VOLTAGE  $U$  across the insulation.*

*For the purpose of determining the OPERATING VOLTAGE  $U$ , the following applies:*

- the apparatus is fed by its RATED SUPPLY VOLTAGE;*
- in case of a.c. voltages, the true peak value including periodic and non-periodic superimposed pulses with a half value time longer than 50 ns shall be measured;*
- in case of d.c. voltages, the peak value of any superimposed ripple shall be included;*
- periodic and non-periodic transients with a half value time up to 50 ns shall be disregarded;*
- unearthed ACCESSIBLE conductive parts shall be assumed to be connected to an earth TERMINAL or to a PROTECTIVE EARTH TERMINAL or contact;*
- where a transformer winding or other part is floating, i.e. not connected to a circuit which establishes its potential relative to earth, it shall be assumed to be connected to an earth TERMINAL or to a PROTECTIVE EARTH TERMINAL or contact at the point which results in the highest OPERATING VOLTAGE being obtained;*
- where DOUBLE INSULATION is used, the OPERATING VOLTAGE across the BASIC INSULATION shall be determined by imagining a short-circuit across the SUPPLEMENTARY INSULATION, and vice versa. For insulation between transformer windings, the short-circuit shall be assumed to take place at the point at which the highest OPERATING VOLTAGE is produced across the other insulation;*
- for insulations between two transformer windings, the highest voltage between any two points in the two windings shall be used, taking into account external voltages to which the windings may be connected;*

– for insulations between a transformer winding and another part, the highest voltage between any point of the winding and the other part shall be used.

The test voltages shall be obtained from a suitable source so designed that, when the output *TERMINALS* are short-circuited after the test voltage has been adjusted to the appropriate level, the output current is at least 200 mA.

An over-current device shall not trip when the output current is less than 100 mA.

Care shall be taken that the value of the test voltage applied is measured within  $\pm 3\%$ .

Initially, not more than half of the prescribed test voltage is applied, then it is raised rapidly to the full value which is held for 1 min.

The measurements of the insulation resistance and the dielectric strength tests are made in the humidity chamber, or in the room in which the apparatus was brought to the prescribed temperature, after the reassembly of those parts which may have been removed.

The apparatus is deemed to comply with the requirement, if the insulation resistance measured after 1 min is not less than the values given in table 3 and no flash-over or breakdown occurs during the dielectric strength test.

When testing enclosures of insulating material, a metal foil is pressed tightly against *ACCESSIBLE* parts.

For apparatus incorporating both *REINFORCED INSULATION* and lower grades of insulation, care shall be taken that the voltage applied to the *REINFORCED INSULATION* does not overstress *BASIC OR SUPPLEMENTARY INSULATION*.

NOTE 2 – *ACCESSIBLE* conductive parts may be connected together during the dielectric strength test.

NOTE 3 – An instrument to carry out the dielectric strength test on thin sheets of insulating material is described in figure 6.

NOTE 4 – The test is not made on insulation the short-circuiting of which does not cause any electric shock hazard, for example in the case where one end of a secondary winding of an *ISOLATING TRANSFORMER* is connected to an *ACCESSIBLE* conductive part, the other end need not meet any insulation requirement with regard to the same *ACCESSIBLE* conductive part.

Resistors, capacitors and RC-units complying with 14.1, 14.2.1 and 14.2.2 respectively, connected in parallel with the insulations to be tested, are disconnected. Inductors and windings which otherwise would prevent the test from being made, are also disconnected.



**Table 3 DU – Test voltages for dielectric strength test and values for insulation resistance**

Table 3 revised June 23, 2000

Insulation	Insulation resistance	AC test voltage (peak) or d.c. test voltage
1 Between parts of different polarity DIRECTLY CONNECTED TO THE MAINS	2 MΩ	For rated MAINS voltages ≤ 150 V (r.m.s.) 1410 V For rated MAINS voltages > 150 V (r.m.s.) 2120 V
2 Between parts separated by BASIC INSULATION or by SUPPLEMENTARY INSULATION	2 MΩ	Curve A of figure 7
3 Between parts separated by REINFORCED INSULATION	4 MΩ	Curve B of figure 7
NOTE 1 – With respect to MAINS voltage in the range of 105 – 130 V (rms), the test voltages are 1414 V peak for BASIC and SUPPLEMENTARY INSULATIONS and 4240 V peak for REINFORCED INSULATION.		
NOTE 2 – Curves A and B of figure 7 are defined by the following points:		
OPERATING VOLTAGE U (peak)	Test voltage (peak)	
	Curve A	Curve B
35 V	707 V	1410 V
354 V		4240 V
1410 V	3980 V	
10 kV	15 kV	15 kV
>10 kV	1.5U V	1.5U V

**11 Fault conditions**

11 revised June 23, 2000

Component power supplies and their power transformers complying with the construction and test requirements of UL 1950, Third Edition, are considered to fulfill the test requirements of this clause

NOTE – To check compliance with the requirements of this clause, it may be necessary to repeat the dielectric strength tests. However, it is advisable to identify beforehand all the insulations to be tested with a higher test voltage in order to avoid more than one humidity treatment.

**11.1 DR Electric shock hazard**

Protection against electric shock shall still exist when the apparatus is operated under fault conditions.

*Compliance is checked by the tests described in clause 9, modified as specified below and under fault conditions.*

*For contacts of TERMINALS*

- the permissible values of 9.1.1 a b) are increased to 70 V (peak) a.c. and 120 V d.c., and
- the permissible values of 9.1.1 b c) are increased to  $U_1 = 70 \text{ V (peak)}$  and  $U_2 = 1.4 \text{ V (peak)}$  for a.c. and to  $U_1 = 4 \text{ V}$  for d.c.; twice the value given

*provided that the plugs for antenna and for earth cannot be inserted into the TERMINAL under test.*

NOTE – It is recommended that for apparatus intended to be used in tropical climates, the values given above be halved.

*If short-circuiting or disconnecting a resistor, a capacitor, an RC-unit, an optocoupler or an inductor causes an infringement of the requirements, the apparatus is still deemed to be satisfactory if the component complies with the relevant requirements of clause 14 (see 4.3.4).*

*If, during the tests, an insulation mentioned in table 3 is subjected to a voltage exceeding the voltage occurring under normal operating conditions, and if this increase involves a higher test voltage according to 10.3, this insulation shall withstand a test for dielectric strength at the higher test voltage, unless the higher voltage is due to the short-circuiting or disconnection of a resistor, a capacitor, an RC-unit, an optocoupler or an inductor complying with the relevant requirements of clause 14.*

## **11.2 Heating**

When the apparatus is operated under fault conditions, no part shall reach such a temperature that:

- there is a danger of fire to the surroundings of the apparatus;
- safety is impaired by abnormal heat developed in the apparatus.

*Compliance is checked by the tests of 11.2.1.*

*During the tests any flame inside the apparatus shall extinguish within a period of 10 s.*

*During the test, solder may soften or become fluid as long as the apparatus does not become unsafe within the sense of this standard.*

*In addition, solder terminations shall not be used as a protective mechanism with the exception of solder which is intended to melt, for example that of THERMAL LINKS.*

### **11.2.1 Measurement of temperature rises**

*The apparatus is operated under fault conditions and the temperature rises are measured after a steady state has been attained, but not later than after 4 h operation of the apparatus.*

*During this period, the apparatus shall meet the requirements of 11.2.2 up to and including 11.2.6.*

*In the case where an applied fault condition results in the interruption of the current before steady state has been reached, the temperature rises are measured immediately after the interruption.*

*If the temperature is limited by fuses, the following additional test is carried out if necessary in relation to the characteristic of the fuse.*

*The fuse-link is short-circuited during the test and the current passing through both the fuse-link and the short-circuit link under the relevant fault condition, is measured:*

- *if this current remains less than 2.1 times the rated current of the fuse-link, the temperatures are measured after a steady state has been attained;*
- *if this current is either immediately 2.1 times the rated current of the fuse-link or more, or reaches this value after a period of time, equal to the maximum pre-arcing time for the relevant current through the fuse-link under consideration, both the fuse-link and the short-circuit link are removed after an additional time corresponding to the maximum pre-arcing time of the fuse-link under consideration and the temperatures are measured immediately.*

*If the fuse resistance influences the current of the relevant circuit, the maximum resistance value of the fuse-link shall be taken into account when establishing the value of the current.*

No Text on This Page

NOTE – The above test is based on the fusing characteristics specified in IEC 60127, which also gives the information necessary to calculate the maximum resistance value.

*In determining the current through the fuse, consideration should be given to the fact that this current may vary as a function of time. It should therefore be measured as soon as possible after switching on, taking into account any delay time for full operation of the circuit under consideration.*

*If a temperature rise exceeding the value given in table 2 is due to short-circuiting an insulation, the apparatus is not deemed to be unsatisfactory, but this insulation shall withstand a dielectric strength test as described in 10.3.*

*If a temperature rise exceeding the value given in table 2 is due to short-circuiting or disconnecting a resistor, a capacitor, an RC-unit, an optocoupler or an inductor, the apparatus is deemed to be satisfactory if the component complies with the relevant requirements of clause 14 (see 4.3.4).*

*If a temperature rise exceeding the value given in table 2 is due to the disconnection of a resistor, the overload test specified in 14.1 b) is repeated on the resistor mounted in the apparatus, including the connections made by the manufacturer.*

*During this test, the connections shall not fail.*

#### **11.2.2 ACCESSIBLE parts**

The temperature rise of ACCESSIBLE parts shall not exceed the values given in table 2, item a), "fault conditions".

#### **11.2.3 Parts, other than windings, providing electrical insulation**

The temperature rise of insulating parts, other than windings, the failure of which would cause an infringement of the requirements of 11.1, 11.2.2, 11.2.4 and 11.2.6, shall not exceed the values given in table 2, item b), "fault conditions", with the following exceptions:

- For PRINTED BOARDS, the temperature rise may exceed, for a maximum period of 5 min, the values given in table 2, item b) "fault conditions", by not more than 100 K.
- For PRINTED BOARDS withstanding the flame test described in 20.1.3, the temperature rise may exceed:
  - a) the values given in table 2, item b) "fault conditions", by not more than 100 K on one or more small areas providing that the total area does not exceed 2 cm<sup>2</sup> for each fault condition and no electric shock hazard is involved, or
  - b) for a maximum period of 5 min, the values given in table 2, item b) "fault conditions", up to the temperature rise value given for "other parts" in table 2, item e) "fault conditions", on one or more small areas, providing that the total area does not exceed 2 cm<sup>2</sup> for each fault condition and no electric shock hazard is involved.

*If a temperature rise value is exceeded and if there is doubt as to whether or not an electric shock hazard exists, a short-circuit is applied between the conductive parts concerned and the tests of 11.1 are repeated.*

*If conductors on PRINTED BOARDS are interrupted, peeled or loosened during the test, the apparatus is still deemed to be satisfactory if all of the following conditions are met:*

- *the PRINTED BOARD complies with 20.1.3;*
- *the interruption is not a POTENTIAL IGNITION SOURCE;*
- *the apparatus complies with the requirements of this subclause with the interrupted conductors bridged;*
- *any peeled or loosened conductor does not reduce the CLEARANCES and CREEPAGE DISTANCES between HAZARDOUS LIVE parts and ACCESSIBLE parts below the values specified in clause 13;*
- *for CLASS I apparatus the continuity of any protective earth connection is maintained; loosening of such a conductor is not allowed.*

#### **11.2.4 Parts acting as a support or a mechanical barrier.**

The temperature rise of parts whose mechanical failure may cause an infringement of the requirements of 9.1.1 shall not exceed the values given in table 2, item c) "fault conditions".

#### **11.2.5 Windings**

The temperature rise of windings shall not exceed the values given in table 2, items b) and d) "fault conditions", with the following exceptions:

- If the temperature is limited due to the operation of replaceable or resettable protective devices, the temperature rises may be exceeded until 2 min after the operation of the device.

*In the case of windings providing protection against electric shock or where a fault could result in a fire hazard, the test is carried out three times and the winding is then subjected to the dielectric strength test of 10.3 without the humidity treatment of 10.2, starting within 1 min after the temperature rise measurement.*

*No failure is allowed.*

- If the temperature is limited due to the operation of an integral non-resettable or a non-replaceable protective device or due to the open circuiting of a winding, the temperature rises may be exceeded but the test shall be carried out three times using new components.

*In the case of windings providing protection against electric shock or where a fault could result in a fire hazard, the winding is then in each case subjected to the dielectric strength test of 10.3 without the humidity treatment of 10.2, starting within 1 min after the temperature rise measurement.*

*No failure is allowed.*

- Higher temperature rises are allowed for windings, provided a failure of their insulation cannot cause an electric shock hazard or a fire hazard and that they are not connected to sources capable of supplying power in excess of 5 W under normal operating conditions.

- If a temperature rise value is exceeded and if there is doubt as to whether or not a hazard exists, the insulation concerned is short-circuited and the tests of 11.1 and 11.2.2 are repeated.

NOTE – If the insulation is incorporated in a winding in such a way that its temperature rise cannot be measured directly, the temperature is assumed to be the same as that of the winding wire.

### 11.2.6 Parts not subject to a limit under 11.2.1 to 11.2.5 inclusive

According to the nature of the material, the temperature rise of the part shall not exceed the values given in table 2, item e) "fault conditions".

## 12 Mechanical strength

### 12.1 DU Complete apparatus

The apparatus shall have adequate mechanical strength and be so constructed as to withstand such handling as may be expected during intended use.

The apparatus shall be so constructed that short-circuiting of insulations between HAZARDOUS LIVE parts and ACCESSIBLE conductive parts or parts conductively connected to those, for example by unintended loosening of screws, is prevented.

*Compliance, except for devices forming a part of the MAINS plug, is checked by the tests of 12.1.1, 12.1.2, and 12.1.3, 12.1.4, 12.1.5 and 12.1.6.*

NOTE – Devices forming a part of the MAINS plug are subjected to the tests as described in 15.4.

#### 12.1.1 Bump test

*Apparatus with a mass exceeding 7 kg are subjected to the following test:*

*The apparatus is placed on a horizontal support of wood which is allowed to fall 50 times from a height of 5 cm onto a wooden table.*

*After the test, the apparatus shall show no damage in the sense of this standard.*

#### 12.1.2 Vibration test

*TRANSPORTABLE APPARATUS intended to be used for audio amplification of musical instruments, PORTABLE APPARATUS and apparatus having a metal enclosure, are subjected to a vibration endurance conditioning by sweeping, as specified in IEC 60068-2-6.*

*The apparatus is fastened in its intended positions of use to the vibration-generator by means of straps round the enclosure. The direction of vibration is vertical, and the severity is:*

Duration	30 minutes
Amplitude	0.35 mm
Frequency range	10 Hz...55 Hz...10 Hz
Sweep range	approximately 1 octave/min

After the test, the apparatus shall show no damage in the sense of this standard, in particular, no connection or part the loosening of which might impair safety shall have loosened.

### 12.1.3 DU Impact test

~~The apparatus is held firmly against a rigid support and is subjected to three blows from a spring-operated impact hammer according to IEC 60068-2-75, applied with a kinetic energy just before impact of 0.5 J to every point of the exterior that protects HAZARDOUS LIVE parts and is likely to be weak, including drawers in the pulled-out position, handles, levers, switch knobs and the like, by pressing the release cone perpendicularly to the surface.~~

~~This test is also made on windows, lenses, signal lamps and their covers, etc. but only if they protrude from the enclosure by more than 5 mm or if the individual projected surface area exceeds 1 cm<sup>2</sup>.~~

~~After the test, the apparatus shall withstand the dielectric strength test as specified in 10.3 and shall show no damage in the sense of this standard; in particular, HAZARDOUS LIVE parts shall not have become ACCESSIBLE, enclosures shall show no visible cracks and insulating barriers shall not have been damaged.~~

NOTE — Damage to the finish, small dents which do not reduce CLEARANCES OR CREEPAGE DISTANCES below the specified values; cracks which are not visible to the naked eye, surface cracks in fibre-reinforced mouldings and the like are ignored.

The enclosure surfaces shall withstand a single impact of the value specified in table 3A. The enclosure bottom is not required to be subjected to the impact test.

The impact force is to be obtained using a solid smooth steel sphere 50 mm in diameter, having a mass or approximately 0.5 kg. The sphere is to move freely from rest through the distance required to result in it striking the enclosure with the specified impact.

Following the test, the apparatus shall withstand the dielectric strength test of 10.3 and shall show no damage in the sense of this standard; in particular, HAZARDOUS LIVE parts shall not have become ACCESSIBLE and insulating barriers shall not have been damaged. Additionally, the apparatus shall comply with the results noted in table 3A.



**Table 3A DU – Apparatus impact test**

Part	Impact, joules	Results in addition to those specified in 12.1.3
<u>Top, sides, back, and front of portable, table-top, or undercabinet apparatus intended for household use, except for parts itemized elsewhere in this table.</u>	2.0	=
<u>Top, sides, back, and front of floor-mounted apparatus intended for household use except for parts itemized elsewhere in this table</u>	3.5	=
<u>Top, sides, back, and front of apparatus intended for commercial use</u>	7.0	=
<u>Glass doors and shelves used in associated stands</u>	2.0	=
<u>Picture-Tube Enclosures</u>		<u>Openings shall not develop such that the projected area of the opening onto a plane perpendicular to a line passing through the center of the opening and any point on the central axis of the bulb section of the picture tube shall not exceed 130 mm<sup>2</sup> unless the minor dimension of the projected area is no more than 10 mm.</u>
<u>CRT &gt; 16 cm</u>	7.0	
<u>CRT ≤ 16 cm</u>	2.0	
<u>Transparent screen over tube face</u>		
<u>CRT &gt; 16 cm</u>	7.0	
<u>CRT ≤ 16 cm</u>	1.0	<u>CREEPAGE and CLEARANCE shall not be reduced to a value less than that in table 4 if a conductive part breaks off and falls into the enclosure</u>
<u>Apparatus intended for household use</u>		
<u>Unprotected<sup>a</sup> buttons, controls, knobs and shafts;</u>	2.0	
<u>Protected<sup>b</sup> buttons, controls, knobs and shafts;</u>	1.0	
<u>Buttons, controls, knobs and shafts located within a compartment having a nondetachable door or cover</u>	0.7	

<sup>a</sup> An unprotected part is one that contacts or passes through an infinite plane placed as close as possible to all top, side, front, or back surfaces with all parts in place.

<sup>b</sup> A protected part is one that does not contact or pass through the infinite plane described in note a).

**12.1.4 DU Drop test**

Each of three samples of a PORTABLE APPARATUS is to be dropped onto a hardwood surface in any position that will likely produce the most adverse results

The height of the drop shall be:

One meter for apparatus that might be held in one hand during any phase of normal operation.

750 mm for all other apparatus.

The horizontal surface consists of hardwood at least 13 mm thick, mounted on two layers of plywood each 19 mm to 20 mm thick, all supported on a concrete or equivalent non-resilient floor.

Each drop shall result in the sample striking the surface in a different position. When applicable, the sample is to be dropped with the batteries specified by the manufacturer. The test criteria shall not be applied through the openings in the face of a CRT and the testing is terminated on the sample if the face of a CRT evacuates in a manner noticeable on the CRT.

Upon conclusion of the test, the apparatus need not be operational, but:

– shall withstand the dielectric strength test as specified in 10.3.

- HAZARDOUS LIVE parts shall not have become ACCESSIBLE.
- insulating barriers shall not have become damaged, and
- CREEPAGE and CLEARANCE DISTANCES shall not have been reduced.

### **12.1.5 DU Mold stress relief test**

ENCLOSURES of molded or formed thermoplastic material shall be so constructed that any shrinkage or distortion of the material due to release of internal stresses caused by the molding or forming operation does not result in the exposure of hazardous parts.

A sample consisting of the apparatus, or of the complete ENCLOSURE together with any supporting framework is placed in an oven and subjected to a temperature 10 K or higher than the maximum temperature observed on the ENCLOSURE during the test in 7.1.3, but not less than 70°C, for a period of 7 h, and then permitted to cool to room temperature.

For large apparatus where it is impractical to test a complete ENCLOSURE, it is permitted to use a portion of the ENCLOSURE with its associated mechanical support members. The section of the ENCLOSURE to be tested shall be representative of the complete assembly with regard to thickness and shape

After the test, dangerous moving parts or HAZARDOUS LIVE parts shall not become ACCESSIBLE

### **12.1.6 DU Handle strength test**

A handle, its securing means, or that portion of the ENCLOSURE to which it is secured shall not break or crack, and the handle shall not detach.

Compliance is checked by the following test:

The weight of the apparatus, plus a weight that exerts a force of three times the weight of the apparatus, is to be uniformly applied over a 75 mm width at the center of the handle, without clamping. The load is to be started at zero and gradually increased so that the test value is attained in 5 - 10 s and maintained for 1 min. When more than one handle is provided, the force is to be distributed between the handles. The distribution of the forces is to be determined by measuring the percentage of the apparatus weight sustained by each handle with the apparatus in the intended carrying position. When the apparatus is furnished with more than one handle, and is capable of being carried by only one handle, each handle shall be capable of sustaining the total force.

## **12.2 Fixing of actuating elements**

Actuating elements, for instance knobs, push buttons, keys and levers, shall be so constructed and fastened that their use will not impair the protection against electric shock.

*Compliance is checked by the following tests.*

*Fixing screws, if any, are loosened and then tightened with 2/3 of the torque given in table 12 and finally loosened for 1/4 turn.*

*The actuating elements are then subjected for 1 min to a torque corresponding to a force of 100 N applied at the periphery, but not more than 1 Nm and, for 1 min, to an axial pull of 100 N. If the mass of the apparatus is less than 10 kg, the pulling force is limited to the value corresponding to the mass of the apparatus but not less than 25 N.*

*For actuating elements such as push buttons, keys and the like, on which only a pressure is exerted during intended use and which do not protrude more than 15 mm from the surface of the apparatus, the pulling force is limited to 50 N.*

*After these tests, the apparatus shall show no damage in the sense of this standard.*

### **12.3 REMOTE CONTROL devices held in hand**

Parts of REMOTE CONTROL devices intended to be held in hand and containing HAZARDOUS LIVE parts, shall have adequate mechanical strength and be so constructed as to withstand such handling as may be expected.

*Compliance is checked by the following test:*

*The REMOTE CONTROL device, with its flexible cord, if any, shortened to 10 cm, is tested according to IEC 60068-2-32, procedure 2.*

*The barrel is rotated 50 times if the mass of the control device is up to 250 g and 25 times if the mass is greater than 250 g.*

*After the test, the device shall show no damage in the sense of this standard.*

*Parts of cable-connected REMOTE CONTROL devices, not intended to be held in hand, are tested as a part of the attended apparatus.*

### **12.4 Drawers**

Drawers which are intended to be partially pulled out from the apparatus shall have a stop of adequate mechanical strength in order to prevent HAZARDOUS LIVE parts becoming ACCESSIBLE.

*Compliance is checked by the following test:*

*The drawer is pulled out in the intended manner until the stop prevents further movement. A force of 50 N is then applied for 10 s in the most unfavourable direction.*

*After the test, the apparatus shall show no damage in the sense of this standard; in particular no HAZARDOUS LIVE parts shall become ACCESSIBLE.*

### **12.5 Antenna coaxial sockets mounted on the apparatus**

Antenna coaxial sockets mounted on the apparatus and incorporating parts or components which isolate HAZARDOUS LIVE parts from ACCESSIBLE parts, shall be so constructed as to withstand such mechanical stresses as may be expected in the intended use.

*Compliance is checked by the following tests, which are made in the order given.*

*After these tests, the apparatus shall show no damage in the sense of this standard.*

#### *Endurance test*

*A test plug as shown in figure 8 is inserted and withdrawn from the socket 100 times. Care is to be taken not to damage the socket intentionally during insertion and withdrawal of the test plug.*

#### *Impact test*

A test plug as shown in figure 8 is inserted into the socket and three successive blows from the spring-operated hammer according to IEC 60068-2-75 are applied with a kinetic energy just before impact of 0.5 J to the same point on the plug in the most unfavourable direction.

#### *Torque test*

A test plug as shown in figure 8 is inserted into the socket and a force of 50 N is applied for 10 s, without jerks, at right angles to the axis of the plug, the radial direction of the force being so as to stress those parts of the socket which are likely to be weak. The force is determined by using, for example, a spring balance attached by means of the hole in the test plug.

*This test is made 10 times.*

NOTE – When antenna coaxial sockets different from IEC 60169-2 [3] are tested, a corresponding test plug of the same length is used for the tests.

## **12.6 DU Telescoping or rod antenna**

A telescoping antenna or rod antenna shall be provided with a minimum 6.0 mm diameter button or ball on the end.

A telescoping or rod antenna shall be provided with a guard or barrier that prevents any part of the antenna or its mounting hardware from falling into the apparatus and contacting LIVE PARTS in the event the antenna or any part of it were to break.

Mounting hardware refers to parts that are subject to stress when the antenna is subject to movement or used to mount the antenna itself.

### **12.6.1 DU Physical securement**

An antenna end piece and the individual section of a telescoping antenna shall be secured in such a manner as to prevent removal.

*Compliance is checked with the following tests.*

The end piece shall be subjected to a 20 N force along the major axis of the antenna for a period of 1 min. In addition, if the end piece is attached by screw threads, a loosening torque in accordance with table 3B is to be applied to the end pieces of five additional samples. The torque is to be applied gradually to the end piece with the antenna fixed in place. When the specified torque value is reached it is to be maintained for no more than 15 s. The average holding time of the five samples shall not be less than 8 s and the holding time for any sample shall not be less than 5 s.

**Table 3B DU– Torque values for end piece test**

<u>End piece diameter, mm</u>	<u>Torque, N•m</u>
<u>Less than 8.0</u>	<u>0.3</u>
<u>Equal to or greater than 8.0</u>	<u>0.6</u>

**12.7 DU Wall or ceiling mounting means**

The mounting means of apparatus intended for wall or ceiling mounting shall be adequate.

Compliance is checked by inspection of the construction and of available data, and where necessary, by the following test.

The apparatus is mounted in accordance with the manufacturer's instructions, a force in addition to the weight of the apparatus is applied downwards through the geometric center of the apparatus, for 1 min. The additional force shall be equal to three times the weight of the apparatus, but not less than 50 N. The apparatus and its associated mounting means shall remain secure during the test.

**12.8 DU Apparatus enclosures, barriers, components, and leads that rely only on adhesives as a fastening means to prevent a risk of electric shock as determined in clause 9.1.1 shall withstand the oven and humidity conditioning tests described without deterioration of the adhesive.**

Two samples are to be conditioned as follows:

- a) One sample placed in an air-circulating oven for 7 days at  $100.0 \pm 1.0^\circ\text{C}$ ; 14 days at  $90.0 \pm 1.0^\circ\text{C}$ ; 21 days at  $87.0 \pm 1.0^\circ\text{C}$ ; or 60 days at  $82.0 \pm 1.0^\circ\text{C}$ ; and
- b) One sample for 7 days in an environment of  $85 \pm 5\%$  relative humidity at  $32.0 \pm 2.0^\circ\text{C}$ .

Compliance is checked by the relevant tests in UL 746C.

**12.8.1 DU A label of conductive material secured in place by an adhesive shall withstand the oven and humidity conditions described in 12.8 when the label is capable of acting as a bridging agent and resulting in a risk of fire or electric shock when dislodged.**

Six samples are to be tested, each secured to its intended mounting surface. Three samples are to be subjected to the air-circulating oven conditioning, and three samples are to be subjected to the humidity conditioning.

Each label shall withstand a minimum peel force of 5.0 N/30 mm width both before and after conditioning.

**13 CLEARANCES and CREEPAGE DISTANCES**

13 revised June 23, 2000

Component power supplies and their power transformers complying with the construction and test requirements of UL 1950, Third Edition, are considered to fulfill the creepage and clearance requirements of this clause.

## 13.1 General

### 13.1.1 CLEARANCES and CREEPAGE DISTANCES shall be dimensioned in accordance with 13.2.

The values are the minimum values which shall be applied, except that they may be reduced by 1 mm for BASIC and SUPPLEMENTARY INSULATION and 2 mm for REINFORCED INSULATION if all the following three conditions are met:

- they are not between ACCESSIBLE conductive parts of an enclosure and HAZARDOUS LIVE parts, if they can be reduced by external forces, as specified in 9.1.7,
- they are maintained by rigid construction;
- their insulation properties are not likely to be significantly affected by any deposition of conductive dust produced inside the apparatus, for example by the carbon brushes of commutator motors.

However, the minimum CLEARANCES and CREEPAGE DISTANCES shall not be reduced below two-thirds of the values given by the curves of figure 9, taking into account any reduction allowed for wire enamel according to note 6 of figure 9, with a minimum of 0.5 mm for BASIC INSULATION OR SUPPLEMENTARY INSULATION, and with a minimum of 1 mm for REINFORCED INSULATION.

Except for insulation between parts of different polarity DIRECTLY CONNECTED TO THE MAINS, CLEARANCES and CREEPAGE DISTANCES smaller than those specified are allowed but are subject to the requirements of 4.3.1, 4.3.2 and 11.2.

The following conditions shall be applied during the assessment for compliance in accordance with 13.2.

*Moveable parts shall be placed in the most unfavourable position.*

*In the determination of CLEARANCES and CREEPAGE DISTANCES between ACCESSIBLE parts and HAZARDOUS LIVE parts, when using the standard test finger, any ACCESSIBLE area of a non-conductive part is considered as being covered with a conductive layer (see figure 3 as an example).*

### 13.1.2 Jointed insulation

Distances between conductive parts along uncemented joints shall be considered as CLEARANCES and CREEPAGE DISTANCES for which the values of figure 9 apply.

For reliably cemented joints, complying with the following tests, CLEARANCES and CREEPAGE DISTANCES do not exist. In this case only 8.8 applies.

*Compliance is checked by inspection, measurement and test.*

*For this test, enamelled winding wires, if any, are replaced by uninsulated wires.*

*The materials are considered to be cemented together, if they withstand the following test:*

*Three apparatus, components or subassemblies are subjected 10 times to the following temperature cycle:*

- 68 h at  $(X \pm 2)^\circ\text{C}$ ,

- 1 h at  $(25 \pm 2)^\circ\text{C}$ ,
- 2 h at  $(0 \pm 2)^\circ\text{C}$ ,
- 1 h at  $(25 \pm 2)^\circ\text{C}$ ,

*whereby X is the highest temperature measured under normal operating conditions on the apparatus, component or subassembly under consideration plus 10 K with a minimum of 85°C.*

No Text on This Page



*Two of the above apparatus, components or subassemblies are then subjected to the relevant dielectric strength test of 10.3, however, the test voltages are multiplied by 1.6.*

*The remaining apparatus, component or subassembly is subjected to the relevant dielectric strength test of 10.3, without the humidity treatment of 10.2, however, the test voltage is multiplied by 1.6.*

*The test is performed immediately at the end of the last period at highest temperature during the thermal cycling test.*

NOTE – The test voltage is higher than the normal test voltage in order to ensure that, if the surfaces are not cemented together, a breakdown occurs.

### **13.2 CLEARANCES and CREEPAGE DISTANCES: dimensions**

CLEARANCES and CREEPAGE DISTANCES shall be dimensioned in accordance with figure 9 taking into account the relevant conditions specified in the notes under the figure.

The specified CLEARANCES are not applicable to air gaps between the contacts of protective devices, switches of microgap construction and similar components where the CLEARANCE varies with the movement of the contacts.

CLEARANCES and CREEPAGE DISTANCES between parts of different polarity DIRECTLY CONNECTED TO THE MAINS shall have the values given in figure 9, curve A, taking into account the reduction allowed in 13.1.1 and/or note 6 of figure 9.

The minimum CLEARANCES and CREEPAGE DISTANCES between conductors, one of which may be CONDUCTIVELY CONNECTED TO THE MAINS, ON PRINTED BOARDS complying with the pull-off and peel strength requirements of IEC 60249-2, are given in figure 10, and for which the following applies:

- these distances only apply as far as overheating is concerned (see 11.2) to the conductors themselves, but not to mounted components or associated soldered connections;
- coatings of lacquer or the like, except coatings according to IEC 60664-3, are ignored when measuring these distances.

*Compliance is checked by measurement taking into account the figures in annex E, subject to conditions detailed in 13.1.1.*

*If necessary, forces shall be applied simultaneously to any point on internal parts and to the outside of conductive enclosures, in an endeavour to reduce the CLEARANCE while taking measurements. The forces shall have a value of:*

- 2 N for internal parts;
- 30 N for enclosures.

*The force shall be applied to the enclosure by means of the rigid test finger according to IEC 61032, test probe 11.*

*If a CLEARANCE consists of two or more airgaps in series separated by conductive parts, any gap of less than 0.2 mm width is ignored in computing the total distance.*

**13.3** For apparatus, subassemblies or components, not CONDUCTIVELY CONNECTED TO THE MAINS and which are enclosed, enveloped or hermetically sealed against ingress of dirt and moisture, the minimum internal CLEARANCES and CREEPAGE DISTANCES may be reduced to the values as given in table 4.

NOTE 1 – Examples of such constructions include hermetically sealed metal boxes, adhesive sealed plastic boxes, parts enveloped in a dip coat or by type A coatings according to IEC 60664-3 of PRINTED BOARDS.

NOTE 2 – This reduction is only permitted as far as protection against electric shock as well as overheating is concerned.

*Compliance is checked by inspection, measurement and by subjecting the apparatus, subassembly or component 10 times to the following temperature cycle:*

- 68 h at  $(Y \pm 2)^\circ\text{C}$ ,
- 1 h at  $(25 \pm 2)^\circ\text{C}$ ,
- 2 h at  $(0 \pm 2)^\circ\text{C}$ ,
- 1 h at  $(25 \pm 2)^\circ\text{C}$ ,

*whereby Y is the highest temperature measured under normal operating conditions of the apparatus, subassembly or component under consideration, with a minimum of 85°C. In case of transformers, Y is the highest winding temperature measured under normal operating conditions, plus 10 K, with a minimum of 85°C.*

*The apparatus, subassembly or component is then subjected to the dielectric strength test of 10.3.*

*The tests are carried out on three samples.*

*No failure is allowed.*

**Table 4 – Minimum CLEARANCES and CREEPAGE DISTANCES  
(enclosed, enveloped or hermetically sealed constructions)**

OPERATING VOLTAGE up to and including V (peak) a.c. or V d.c.	Minimum CLEARANCES and CREEPAGE DISTANCES (mm)
35	0.2
45	0.2
56	0.3
70	0.3
90	0.4
110	0.4
140	0.5
180	0.7
225	0.8
280	1.0
360	1.1
450	1.3
560	1.6
700	1.9
900	2.3
1,120	2.6

Table 4 – Minimum CLEARANCES and CREEPAGE DISTANCES Continued on Next Page

**Table 4 – Minimum CLEARANCES and CREEPAGE DISTANCES Continued**

OPERATING VOLTAGE up to and including V (peak) a.c. or V d.c.	Minimum CLEARANCES and CREEPAGE DISTANCES (mm)
1,400	3.2
1,800	4.2
2,250	5.6
2,800	7.5
3,600	10.0
4,500	12.5
5,600	16.0
7,000	20.0
9,000	25.0
11,200	32.0
14,000	40.0

NOTE 1 – The values are applicable to both BASIC and SUPPLEMENTARY INSULATION.  
NOTE 2 – The values for REINFORCED INSULATION shall be twice the values in the table.  
NOTE 3 – A minimum CTI (comparative tracking index) of 100 is required for the insulating materials used. The CTI rating refers to the value obtained in accordance with IEC 60112, solution A.  
NOTE 4 – Linear interpolation between the nearest two points is allowed, the calculated spacing being rounded to the next higher 0.1 mm increment.

**13.4** The distances between conductive parts internal to apparatus, subassemblies or components which are treated with insulating compound filling all voids, so that CLEARANCES and CREEPAGE DISTANCES do not exist, shall be subject only to the requirements of 8.8.

NOTE – Examples of such treatment include potting, encapsulation and vacuum impregnation.

*Compliance is checked in accordance with the 13.3, taking into account 8.8 together with the following:*

*A visual inspection shall show that there are no cracks in the encapsulating, impregnating or other material, that coatings have not loosened or shrunk, and after sectioning the sample, that there are no significant voids in the material.*

**13.5 DC** For type B coated PRINTED BOARDS, insulation between conductors shall comply with applicable requirements of IEC 60664-3 UL 746C. This applies only to BASIC INSULATION.

NOTE – For SUCH PRINTED BOARDS, CLEARANCES and CREEPAGE DISTANCES under the coating do not exist.

## 14 DC Components

14 revised June 23, 2000

NOTE 1 – Where components are part of a range of values it is usually not necessary to test every value within that range. If this range of values consists of several technologically homogeneous subranges, the samples should be representative of each of these subranges. Moreover, it is recommended, where possible, to make use of the concept of structurally similar components.

NOTE 2 – When a certain flammability category according to IEC 60707 is required, reference is made to annex G with respect to alternative test methods.

NOTE 3 – When no flammability requirements are specified in this clause, reference is made to 20.1.1.

Except as indicated below, a component of an apparatus covered by this standard shall comply with the requirements for that component. See annex S for a list of standards covering components used in the apparatus covered by this standard.

A component is not required to comply with a specific requirement that:

- a) Involves a feature or characteristic not required in the application of the component in the apparatus covered by the standard, or
- b) Is superseded by a requirement in this standard.

A component shall be used in accordance with its rating established for the intended conditions of use.

Specific components are incomplete in construction features or restricted in performance capabilities. Such components are intended for use only under limited conditions, such as certain temperatures not exceeding specified limits, and shall be used only under those specific conditions.

#### 14.1 Resistors

Resistors the short-circuiting or disconnecting of which would cause an infringement of the requirements for operation under fault conditions (see clause 11) and resistors bridging contact gaps of MAINS switches, shall have an adequate stable resistance value under overload

Such resistors shall be positioned inside the enclosure of the apparatus.

*Compliance is checked by test a) or test b), carried out on a sample of 10 specimens.*

*Before test a) or b), the resistance of each specimen is measured and the sample is then subjected to the damp heat test according to IEC 60068-2-3, severity 21 days.*

*a) For resistors connected between HAZARDOUS LIVE parts and ACCESSIBLE conductive parts and for resistors bridging contact gaps of MAINS switches, the 10 specimens are each subjected to 50 discharges at a maximum rate of 12/min, from a 1 nF capacitor charged to 10 kV in a test circuit as shown in figure 5A.*

*After this test, the value of resistance shall not differ more than 20% from the value measured before the damp heat test.*

*No failure is allowed.*

*b) For other resistors, the 10 specimens are each subjected to a voltage of such a value that the current through it is 1.5 times the value measured through a resistor, having a resistance equal to the specified rated value, which is fitted to the apparatus, when operated under fault conditions. During the test the voltage is kept constant.*

*The value of resistance is measured when steady state is attained and shall not differ more than 20% from the value measured before the damp heat test.*

*No failure is allowed.*

For resistors connected between HAZARDOUS LIVE parts and ACCESSIBLE conductive parts, the CLEARANCES and CREEPAGE DISTANCES between the terminations shall comply with the requirements of clause 13 for REINFORCED INSULATION.

Resistors with internal end-lead terminations are allowed only if the internal spacings are clearly and precisely defined.

*Compliance is checked by measurement and inspection.*

## 14.2 DC Capacitors and RC-units

14.2 revised June 23, 2000

Component power supplies and their capacitors complying with the construction and test requirements of UL 1950, Third Edition, are considered to fulfill the construction and test requirements of sub-clauses 14.2.1 – 14.2.5.

Where reference is made to the tests specified in IEC 60384-14, table II, these tests are supplemented as follows:

The duration of the damp heat steady-state test as specified in IEC 60384-14, subclause 4.12, shall be 21 days.

NOTE – Reference is made to IEC 60384-14:1993 including amendment 1 (1995) and UL 1414, irrespective of whether the capacitor or RC-unit is used for electromagnetic interference suppression purposes or not.

**14.2.1 DC Capacitors or RC-units, the short-circuiting or disconnecting of which would cause an infringement of the requirements under fault conditions with regard to electric shock hazard shall:**

a) withstand the tests for subclass Y2 or Y4 capacitors or RC-units as specified in IEC 60384-14, table II.

Subclass Y2 capacitors or RC-units shall be applied for apparatus with rated MAINS voltages >150 V and ≤250 V with respect to earth or to the neutral respectively.

Subclass Y4 capacitors or RC-units may be applied only for apparatus with rated MAINS voltages ≤150 V with respect to earth or to the neutral respectively.

b) withstand the tests for subclass Y1 or Y2 capacitors or RC-units as specified in IEC 60384-14, table II.

Subclass Y1 capacitors or RC-units shall be applied for apparatus with rated MAINS voltages >150 V and ≤250 V with respect to earth or neutral respectively.

Subclass Y2 capacitors or RC-units may be applied only for apparatus with rated MAINS voltages ≤150 V with respect to earth or neutral respectively.

NOTE – For the application of a) and b), reference is made to 8.5 and 8.6.

Such capacitors or RC-units shall be positioned inside the enclosure of the apparatus.

As an alternative a component such as a capacitor, a combination capacitor and resistor, or a suppressor shall comply with the requirements for Antenna-Coupling, Line-By-Pass, or Double Protection in UL 1414, as applicable.

**14.2.2 DC** Capacitors or RC-units having their terminations DIRECTLY CONNECTED TO THE MAINS, shall withstand the tests for subclass X1 or X2 capacitors or RC-units as specified in IEC 60384-14, table II.

Subclass X1 capacitors or RC-units shall be applied for PERMANENTLY CONNECTED APPARATUS intended for connection to a MAINS with a nominal voltage  $>150$  V and  $\leq 250$  V with respect to earth or neutral respectively.

Subclass X2 capacitors or RC-units may be used for all other applications.

NOTE 1 – Y2 capacitors or RC-units may be used instead of X1 or X2 capacitors or RC-units.

NOTE 2 – Y4 capacitors or RC-units may be used instead of X2 capacitors or RC-units in applications  $\leq 150$  V.

As an alternative a component such as a capacitor, a combination capacitor and resistor, or a varistor, or a suppressor shall comply with the requirements for Across-the-Line, Antenna-Coupling, or Double Protection in UL 1414.

**14.2.3** Capacitors or RC-units in a.c. circuits with MAINS frequency not CONDUCTIVELY CONNECTED TO THE MAINS, the short-circuiting of which would cause an infringement of the requirements with regard to overheating, shall withstand the tests for subclass X2 capacitors or RC-units as specified in IEC 60384-14, table II.

The characteristics of the capacitors or RC-units shall be appropriate for their function in the apparatus under normal operating conditions.

~~**14.2.4 DC** Intentionally kept free for future requirements for capacitors or RC-units other than those mentioned in 14.2.1 to 14.2.3. Components which have been subjected to the requirements in 14.2.1 and 14.2.2 shall also comply with the enclosure requirements of UL 1414.~~

**14.2.5** Capacitors or RC-units with a volume exceeding  $1750 \text{ mm}^3$  used in circuits where, when the capacitor or RC-unit is short-circuited, the current through the short-circuit exceeds 0.2 A, shall comply with the passive flammability requirements according to IEC 60384-1, subclause 4.38, flammability category B or better. Capacitors or RC-units with a volume less than  $1750 \text{ mm}^3$  need not meet requirements for passive flammability.

When the distance between POTENTIAL IGNITION SOURCES and capacitors or RC-units with a volume exceeding  $1750 \text{ mm}^3$  does not exceed the values specified in table 5, then these capacitors or RC-units shall comply with the relevant passive flammability requirements according to IEC 60384-1, subclause 4.38 as specified in the table 5 or better.

Where these capacitors or RC-units are shielded by a barrier meeting the flammability category FV 0 according to IEC 60707 or a barrier made of metal, no requirements shall apply. The barrier shall have dimensions covering at least the areas specified in table 5 and shown in figure 13.

These requirements are not applicable to capacitors or RC-units having a metal case. Thin coatings on such a case are ignored.

*Compliance is checked according to IEC 60384-1, subclause 4.38.*

**Table 5 – Flammability category related to distance  
from POTENTIAL IGNITION SOURCES**

Open circuit voltage of the POTENTIAL IGNITION SOURCE	Distance from POTENTIAL IGNITION SOURCES to the capacitor or RC-unit downwards or sideways less than <sup>1)</sup> mm	Distance from POTENTIAL IGNITION SOURCES to the capacitor or RC-unit upwards less than <sup>1)</sup> mm	Passive flammability category according to IEC 60384-1
> 50 V to ≤ 4000 V (peak) a.c. or d.c.	13	50	B
> 4 kV (peak) a.c. or d.c.	D <sup>2)</sup>	D <sup>3)</sup>	B
<sup>1)</sup> See figure 13. <sup>2)</sup> Where D is 13 mm or the open-circuit voltage of the POTENTIAL IGNITION SOURCE in kilovolts, whichever is larger. <sup>3)</sup> Where D is 50 mm or the open-circuit voltage of the POTENTIAL IGNITION SOURCE in kilovolts, whichever is larger.			

### 14.3 Inductors and windings

14.3 revised June 23, 2000

Component power supplies and their inductors and windings complying with the construction and test requirements of UL 1950, Third Edition, are considered to fulfill the construction and test requirements of sub-clauses 14.3.1 – 14.3.5.2.

#### 14.3.1 Marking

Inductors the failure of which can impair the safety of an apparatus, for example ISOLATING TRANSFORMERS, shall be marked with the manufacturer's name or trademark and with a type or catalogue reference. The manufacturer's name and the type reference may be replaced by a code number.

*Compliance is checked by inspection.*

#### 14.3.2 General

NOTE 1 – Depending on the application in the APPARATUS attention is drawn to the requirements of 10.1 for the insulation of windings.

ISOLATING TRANSFORMERS shall comply with:

- 14.3.3 and
- 14.3.4.1 or 14.3.4.2 and
- 14.3.5.1 or 14.3.5.2.

SEPARATING TRANSFORMERS shall comply with:

- 14.3.3 and
- 14.3.4.3 and
- 14.3.5.1 or 14.3.5.2.

Other windings, for example induction motors where the power is supplied to the stator only, degaussing coils, relay coils, autotransformers, shall comply with 14.3.3.1, 14.3.5.1 and 14.3.5.2 as far as applicable.

Transformers for switch mode power supplies (SMPS) shall comply with the requirements as for ISOLATING TRANSFORMERS as far as applicable.

NOTE 2 – Special requirements for SMPS transformers are under consideration.

Insulating material of inductors and windings, except in thin sheet form, shall comply with 20.1.4.

### **14.3.3 Constructional requirements**

#### **14.3.3.1 All windings**

CLEARANCES and CREEPAGE DISTANCES shall comply with the requirements of clause 13.

#### **14.3.3.2 Designs with more than one winding**

When an insulation barrier consisting of an uncemented pushed-on partition wall is used, CREEPAGE DISTANCES are measured through the joint. If the joint is covered by an adhesive bonding tape in accordance with IEC 60454, one layer of adhesive bonding tape is required on each side of the wall in order to reduce the risk of tape folding over during production.

The input and output windings shall be electrically separated from each other, and the construction shall be such that there is no possibility of any connection between these windings, either directly or indirectly through conductive parts.

In particular, precautions shall be taken to prevent:

- undue displacement of input or output windings, or the turns thereof;
- undue displacement of internal wiring, or wires for external connections;
- undue displacement of parts of windings, or of internal wiring, in the event of rupture of wires, or loosening of connections;
- wires, screws, washers and the like from bridging any part of the insulation between the input and output windings, including the connections of windings, should they loosen or become free.

The last turn of each winding shall be retained in a reliable manner, for example by tape, suitable bonding agent, or retention shall be implied by process technology.

Where cheekless bobbins are used, the end turns of each layer shall be retained in a reliable manner. Each layer can, for example, be interleaved with adequate insulation material projecting beyond the end turns of each layer and, moreover, either

- the windings shall be impregnated with hard-baking or cold-setting material, substantially filling the intervening spaces and effectively sealing-off the end turns, or
- the windings shall be held together by means of insulating material, or
- the windings shall, for example, be fixed by process technology.



NOTE – It is not expected that two independent fixings will become loose at the same time.

Where serrated tape is used, the serrated part is disregarded as insulation.

*Compliance is checked by inspection.*

No Text on This Page

### 14.3.4 Separation between windings

#### 14.3.4.1 Windings of CLASS II construction

The separation between HAZARDOUS LIVE windings and windings intended to be connected to ACCESSIBLE conductive parts shall consist of DOUBLE OR REINFORCED INSULATION according to 8.8, except that for coil formers and partition walls providing REINFORCED INSULATION a thickness of at least 0.4 mm without additional requirements applies.

Where an intermediate conductive part, for example the iron core, not intended to be connected to ACCESSIBLE conductive parts is located between the relevant windings, the insulation between these windings via the intermediate conductive part shall consist of DOUBLE OR REINFORCED INSULATION as mentioned above.

*Compliance is checked by inspection and by measurement.*

#### 14.3.4.2 Windings of CLASS I construction

The separation between HAZARDOUS LIVE windings and windings intended to be connected to ACCESSIBLE parts may consist of BASIC INSULATION plus PROTECTIVE SCREENING only if all of the following conditions are complied with:

- the insulation between HAZARDOUS LIVE windings and the protective screen shall comply with the requirements for BASIC INSULATION according to 8.8 dimensioned for the HAZARDOUS LIVE voltage;
- the insulation between the protective screen and non-HAZARDOUS LIVE windings shall comply with the requirements for dielectric strength according to table 3, item 2;
- the protective screen intended to be connected to a PROTECTIVE EARTH TERMINAL or contact shall be positioned between the input and output windings in such a way that the screen effectively prevents the input voltage being applied to any output winding in case of an insulation fault;
- the protective screen shall consist of a metal foil or of a wire wound screen extending at least the full width of one of the windings adjacent to the screen. A wire wound screen shall be wound tight without space between the turns;
- the protective screen shall be so arranged that its ends cannot touch each other nor touch simultaneously an iron core, in order to prevent losses due to creation of a shorted winding;
- the protective screen and its lead-out wire shall have a cross-sectional area sufficient to ensure that if a breakdown of insulation should occur, a fusing or interrupting device will open the circuit before the screen or the lead-out wire is destroyed;
- the lead-out wire shall be connected to the protective screen in a reliable manner, for example by soldering, welding, riveting or crimping.

*Compliance is checked by inspection and by measurement.*

#### 14.3.4.3 Windings of separating construction

The separation between HAZARDOUS LIVE windings and windings intended to be connected to parts separated from ACCESSIBLE parts by SUPPLEMENTARY INSULATION only shall consist of at least BASIC INSULATION according to 8.8.

*Compliance is checked by inspection and by measurement.*

#### 14.3.5 Insulation between HAZARDOUS LIVE parts and ACCESSIBLE parts

##### 14.3.5.1 Windings of CLASS II construction

The insulation between HAZARDOUS LIVE windings and ACCESSIBLE parts or parts intended to be connected to ACCESSIBLE conductive parts, for example the iron core.

and

the insulation between HAZARDOUS LIVE parts, for example the iron core connected to a HAZARDOUS LIVE winding, and windings intended to be connected to ACCESSIBLE conductive parts,

shall consist of DOUBLE OR REINFORCED INSULATION according to 8.8, except that for coil formers and partition walls providing REINFORCED INSULATION a thickness of at least 0.4 mm without additional requirements applies.

*Compliance is checked by inspection and measurement.*

##### 14.3.5.2 DU Windings of CLASS I construction

The insulation between HAZARDOUS LIVE windings and ACCESSIBLE conductive parts or parts intended to be connected to ACCESSIBLE conductive parts connected to a PROTECTIVE EARTH TERMINAL OR CONTACT, for example the iron core,

and

the insulation between HAZARDOUS LIVE parts, for example the iron core connected to a HAZARDOUS LIVE winding, and winding wires or foils of protective screens intended to be connected to a PROTECTIVE EARTH TERMINAL OR CONTACT.

shall consist of BASIC INSULATION according to 8.8.

The winding wires of windings intended to be connected to a PROTECTIVE EARTH TERMINAL OR CONTACT shall have a current carrying capacity sufficient to ensure that, if a breakdown of insulation should occur, a fusing or interrupting device will open the circuit before the winding is destroyed.

*Compliance is checked by inspection and measurement.*

#### 14.4 DU High voltage components and assemblies

NOTE 1 – For high voltage cables reference is made to 20.1.2.

NOTE 2 – The clearance distance specified in this clause is to include the straight line distance, between conductive parts operating at voltages exceeding 4 kV (peak) located within the component and conductive parts of opposite polarity that are located external to the component, through any insulating material that has not been found reliable with regard to temperature and voltage involved, and has no arc-tracking characteristic as determined by the tests in the Standard Test for High-Voltage, Low-Current, Arc Resistance of Solid Electrical Insulating Material, ASTM D495.

Components operating at voltages exceeding 4 kV (peak) and spark gaps provided to protect against overvoltages, if not otherwise covered by 20.1.3, shall not give rise to danger of fire to the surroundings of the apparatus, or to any other hazard within the sense of this standard.

Compliance is checked by:

- meeting the requirement for category FV1 according to IEC 60707 or by the test of 14.4.1, in which no failure is allowed: V-2 according to UL 94 and either
- conducting the test in 14.4.1 in the apparatus on all exterior materials of the component where all the exterior materials are rated not less than V-2, and on all materials of any associated part that are rated not less than V-2 that are located between the component and conductive part at a different potential, where the clearance distance between the component and conductive part is less than the distance specified in figure 18 for the potential involved, or
- conducting the test in 14.4.2 on all exterior materials of the component where all of the external materials are rated not less than HB, and on all materials of any associated part rated not less than HB that are located between the component and a conductive part of opposite polarity where the clearance distance between the component and conductive part is less than the distance specified in figure 18 for the potential involved.

A component, such as a high-voltage transformer:

- a) Operating at voltage of more than 4 kV (peak).
- b) Having at least one winding connected to the MAINS, and
- c) Having another winding, located within the same component housing that is connected to an ACCESSIBLE part

shall withstand the conditioning and dielectric voltage-withstand test described in 14.4.3. There shall be no breakdown of the insulating materials when breakdown results in a risk of electric shock.

#### **14.4.1 DU High voltage transformers and multipliers arcng test**

~~Three specimens of the transformer with one or more high-voltage windings or of the high-voltage multipliers are subjected to the treatment specified under item a), followed by the test specified under item b):~~

- a) ~~Preconditioning~~

~~For transformers, a power of 10 W (d.c. or a.c. at MAINS frequency) is initially supplied to the high-voltage winding. This power is sustained for 2 min, after which it is increased by successive steps of 10 W at 2 min intervals to 40 W.~~

~~The treatment lasts 8 min or is terminated as soon as interruption of the winding or appreciable splitting of the protective covering occurs.~~

NOTE 1— Certain transformers are so designed that this preconditioning cannot be carried out. In such cases, only the test of item b) below is applied:

*For high-voltage multipliers, a voltage taken from an appropriate high-voltage transformer, is supplied to each specimen, its output circuit being short-circuited.*

*The input voltage is adjusted so that the short-circuit current is initially  $(25 \pm 5)$  mA. This is maintained for 30 min or is terminated as soon as any interruption of the circuit or appreciable splitting of the protective covering occurs.*

NOTE 2— Where the design of a high-voltage multiplier is such that a short-circuit current of 25 mA cannot be obtained, a preconditioning current is used, which represents the maximum attainable current, determined either by the design of the multiplier or by its conditions of use in a particular apparatus:

*b) Flame test*

*The specimen is subjected to the flame test of clause G.1.2, annex G.*

*A component operating at more than 4 kV (peak) or a part of a different potential with less than the specified clearance distance shall not produce a risk of fire when subjected to the following arcing test.*

*For this test, voltages are to be measured with and without any accessories, with and without any one tube and fuse (exclusive of copper or copper alloy links in any low-voltage heater circuit) disabled in any manner that occurs in service, and with any combination of these conditions. All controls are to be adjusted to give the maximum voltage possible with a useable picture. Following this adjustment, all external operating controls and all user controls that are externally marked to identify their purpose are to be adjusted to produce the maximum voltage,  $V_1$ , regardless of the effect on the picture. An automatic voltage regulating device that continues to perform its intended function under a single fault condition is not to be rendered inoperative for this test.*

*All components operating at more than 4 kV (peak) shall be conditioned for 168 hours in a full draft circulating-air oven at a temperature  $20^\circ\text{C}$  higher than the normal operating temperature of the component, and not less than  $70^\circ\text{C}$ . The oven is to maintain a tolerance of  $+2.0^\circ\text{C}$ .*

*An arc, using the energy available from the high-voltage component, is to be established between the component and any adjacent part of different potential where breakdown will occur due to deficiency in clearance distance. The arc is to be used to attempt to ignite exterior materials of the high-voltage component and to ignite materials of associated parts located between the high-voltage component and parts of different potential. The arc is to be established by means of a conductive probe. The conductive probe is to be used to break through unreliable insulation or to create arc tracking across the surface of insulating materials (for example, tube sockets, or terminal boards). The arc length developed with the probe is not to exceed the distance specified in figure 18. The arcing is to be continued for 15 min at each location. When flaming occurs, the arc is to be extinguished by disconnecting power to the apparatus and the time of flaming measured. When the flame self-extinguishes in less than 30 sec, the arcing is to be re-established and continued for a total arcing time of 15 min. If arcing cannot be maintained using the above conditions of operation, a minimum value of impedance, necessary to maintain arcing, shall be added to the probe circuit in order to maintain arcing conditions for the required time period. The results are considered unsatisfactory if flame resulting from the arcing continues for more than 30 seconds after arcing is discontinued.*

#### **14.4.2 DU Component part flame test**

Exterior materials of a component operating at more than 4 kV (peak) shall not continue to flame for more than 10 seconds after each application of five 15 sec test flames and after the fifth application of the test flame, conductive internal high-voltage parts shall not be exposed. The period between applications of the flame is 15 seconds. The test flame is to be obtained from a 9.5 mm diameter Tirrill burner adjusted to give a flame 13 cm high with a 4 cm blue inner cone. The tip of the inner cone of the flame is to be applied to the part under test.

#### **14.4.3 DU High-voltage isolating component**

Three samples of the high-voltage component, connected as in normal operation, are to be conditioned in a circulating-air oven. The operating temperature of the oven is that required for the component winding to reach the winding aging temperature. The winding aging temperature is obtained from the horizontal axis of figure 19. This temperature is determined by the intersection of the aging time and historical class 105 (A) system response curve in figure 19. The aging time is determined by the manufacturer. The curve used shall not be less than the normal operating temperature of the winding of the component.

After completion of the conditioning, the samples are to be allowed to cool to room temperature and subjected to the dielectric voltage-withstand test described in 10.3.

### **14.5 Protective devices**

The application of protective devices shall be in accordance with their rated values.

External CLEARANCES and CREEPAGE DISTANCES of protective devices and their connections shall meet the requirements for BASIC INSULATION of clause 13 for the voltage across the device when opened.

*Compliance is checked by measurement or calculation.*

#### **14.5.1 DU THERMAL RELEASES**

THERMAL RELEASES used in order to prevent the apparatus from becoming unsafe within the sense of this standard shall comply with 14.5.1.1, or 14.5.1.2 or 14.5.1.3 respectively, whichever is applicable.

**14.5.1.1 DC THERMAL CUT-OUTS** shall meet one of the following requirements: comply with UL 8730-2-9.

a) The THERMAL CUT-OUT when tested as a separate component, shall comply with the requirements and tests of IEC 60730 series as far as applicable.

For the purpose of this standard the following applies:

- the THERMAL CUT-OUT shall be of type 2 action (see IEC 60730-1, subclause 6.4.2);
- the THERMAL CUT-OUT shall have at least MICRO-DISCONNECTION (type 2B) (see IEC 60730-1, subclauses 6.4.3.2 and 6.9.2);
- the THERMAL CUT-OUT shall have a TRIP-FREE mechanism in which contacts cannot be prevented from opening against a continuation of a fault (type 2E) (see IEC 60730-1, subclause 6.4.3.5);
- the number of cycles of automatic action shall be at least:

- 3000 cycles for THERMAL CUT-OUTS with automatic reset used in circuits which are not switched-off when the apparatus is switched-off (see IEC 60730-1, subclause 6.11.8);
  - 300 cycles for THERMAL CUT-OUTS with automatic reset used in circuits which are switched-off together with the apparatus and for THERMAL CUT-OUTS with no automatic reset which can be reset BY HAND from the outside of the apparatus (see IEC 60730-1, subclause 6.11.10);
  - 30 cycles for THERMAL CUT-OUTS with no automatic reset and which cannot be reset BY HAND from the outside of the apparatus (see IEC 60730-1, subclause 6.11.11);
- the THERMAL CUT-OUT shall be tested as designed for a long period of electrical stress across insulating parts (see IEC 60730-1, subclause 6.14.2);
- the THERMAL CUT-OUT shall meet the ageing requirements for an intended use of at least 10,000 h (see IEC 60730-1, subclause 6.16.3);
- with regard to the dielectric strength, the THERMAL CUT-OUT shall meet the requirements of 10.3 of this standard, except across the contact gap, and except between terminations and connecting leads of the contacts, for which IEC 60730-1, subclauses 13.2 to 13.2.4 applies.

The characteristics of the THERMAL CUT-OUT with regard to:

- the ratings of the THERMAL CUT-OUT (see IEC 60730-1, clause 5);
- the classification of the THERMAL CUT-OUT according to:
  - nature of supply (see IEC 60730-1, subclause 6.1);
  - type of load to be controlled (see IEC 60730-1, subclause 6.2);
  - degree of protection provided by enclosures against ingress of solid objects and dust (see IEC 60730-1, subclause 6.5.1);
  - degree of protection provided by enclosures against harmful ingress of water (see IEC 60730-1, subclause 6.5.2);
  - pollution situation for which the THERMAL CUT-OUT is suitable IEC 60730-1, subclause 6.5.3);
  - maximum ambient temperature limit (see IEC 60730-1, subclause 6.7);

shall be appropriate for the application in the apparatus under normal operating conditions and under fault conditions:

*Compliance is checked according to the test specifications of IEC 60730 series, by inspection and by measurement.*

b) The THERMAL CUT-OUT when tested as a part of the apparatus shall:



- have at least ~~MICRO-DISCONNECTION~~ according to IEC 60730-1 withstanding a test voltage according to subclause 13.2 of IEC 60730-1, and
- have a ~~TRIP-FREE~~ mechanism in which contacts cannot be prevented from opening against a continuation of a fault and
- be aged for 300 h at a temperature corresponding to the ambient temperature of the ~~THERMAL CUT-OUT~~ when the apparatus is operated under normal operating conditions at an ambient temperature of 35°C (45°C for apparatus intended for use in tropical climates), and
- be subjected to a number of cycles of automatic action as specified under a) for a ~~THERMAL CUT-OUT~~ tested as a separate component, by establishing the relevant fault conditions.

The test is made on three specimens:

No sustained arcing shall occur during the test.

After the test, the ~~THERMAL CUT-OUT~~ shall show no damage in the sense of this standard. In particular, it shall show no deterioration of its enclosure, no reduction of ~~CLEARANCES~~ and ~~CREEPAGE DISTANCES~~ and no loosening of electrical connections or mechanical fixings.

*Compliance is checked by inspection and by the specified tests in the given order.*

**14.5.1.2 DC** ~~THERMAL LINKS~~ shall meet one of the following requirements: comply with UL 1020.

a) The ~~THERMAL LINK~~ when tested as a separate component, shall comply with the requirements and tests of IEC 60691:

The characteristics of the ~~THERMAL LINK~~ with regard to

- the ambient conditions (see IEC 60691, subclause 6.1);
- the circuit conditions (see IEC 60691, subclause 6.2);
- the ratings of the ~~THERMAL LINK~~ (see IEC 60691), subclause 8 b);
- the suitability for sealing in or use with impregnating fluids or cleaning solvents (see IEC 60691, subclause 8 c);

shall be appropriate for the application in the apparatus under normal operating conditions and under fault conditions.

The dielectric strength of the ~~THERMAL LINK~~ shall meet the requirements of 10.3 of this standard except across the disconnection (contact parts) and except between terminations and connecting leads of the contacts, for which IEC 60691, subclause 11.3 applies.

*Compliance is checked according to the test specifications of IEC 60691, by inspection and measurement.*

b) The ~~THERMAL LINK~~ when tested as a part of the apparatus shall be:

- aged for 300 h at a temperature corresponding to the ambient temperature of the THERMAL LINK when the apparatus is operated under normal operating conditions at an ambient temperature of 35°C (45°C for apparatus intended for use in tropical climates); and
- subjected to such fault conditions of the apparatus which cause the THERMAL LINK to operate. During the test no sustained arcing and no damage in the sense of this standard shall occur, and
- capable of withstanding two times the voltage across the disconnection and have an insulation resistance of at least 0.2 MΩ, when measured with a voltage equal to two times the voltage across the disconnection.

The test is made 10 times, no failure is allowed.

The THERMAL LINK is replaced, partially or completely, after each test.

NOTE — When the THERMAL LINK cannot be replaced partially or completely, the complete component part comprising the THERMAL LINK, for example a transformer, should be replaced.

*Compliance is checked by inspection and by the specified tests in the given order.*

14.5.1.2 revised June 23, 2000

**14.5.1.3** ~~DU~~ Thermal interrupting devices which are intended to be reset by soldering shall be tested according to 14.5.1.2 b).

However, the interrupting element is not replaced after operation, but reset according to the instructions of the apparatus manufacturer or, in absence of instructions, soldered with standard 60/40 tin/lead solder.

NOTE — Examples of interrupting devices which are intended to be reset by soldering, are THERMAL RELEASES, integrated, on power resistors, for example externally.

## 14.5.2 Fuse-links and fuse holders

**14.5.2.1** **DC** Fuse-links, DIRECTLY CONNECTED TO THE MAINS, used in order to prevent the apparatus from becoming unsafe within the sense of this standard shall comply with the relevant part of IEC 60127, unless they have a rated current outside the range specified in that standard UL 248-14.

In the latter case they shall comply with the relevant part of IEC 60127 as far as applicable.

*Compliance is checked by inspection.*

**14.5.2.2** **DC** For fuse-links according to IEC 60127, the following marking shall be located on each fuse-holder or close to the fuse-link, in the given order:

- a symbol denoting the relative prearcing time/current characteristic;

examples are:

F, denoting quick acting;

T, denoting time lag;

– the rated current in milliamperes for rated currents below 1 A, and in amperes for rated currents of 1 A or more;

– the voltage rating

– a symbol denoting the breaking capacity of the assigned fuse-link;

examples are:

L, denoting low breaking capacity;

E, denoting enhanced breaking capacity;

H, denoting high breaking capacity

Examples of marking:

T 0,315 L or T 315 mA L 125 V

F 1.25 H or F 1.25 A H 250 V

However, it is permissible to locate the marking elsewhere, in or on the apparatus, provided that it is obvious to which fuseholder the marking applies.

~~The marking requirements apply also if the fuse-links have a rated current outside the range specified in IEC 60127.~~

*Compliance is checked by inspection.*

**14.5.2.3** Fuse holders so designed that fuse-links can be connected in parallel in the same circuit, shall not be used.

*Compliance is checked by inspection.*

**14.5.2.4 DC** If HAZARDOUS LIVE parts are rendered ACCESSIBLE during replacement of fusing or interrupting devices, access to such parts shall not be possible BY HAND operation.

Fuse-holders for miniature cartridge fuse-links of the screw-in or bayonet type shall, if removal of the fuse-carrier BY HAND is possible from the outside of the apparatus, be so constructed that HAZARDOUS LIVE parts do not become ACCESSIBLE, either during insertion or removal of the fuse-link, or after the fuse-link has been removed. ~~Fuse holders in compliance with IEC 60127-6 satisfy this requirement.~~

When the fuse carrier is constructed to hold the fuse-link, the fuse-link is placed in the fuse-carrier during the test.

*Compliance is checked by inspection.*

### 14.5.3 DC PTC-S THERMISTORS

PTC-S THERMISTORS used in order to prevent the apparatus from becoming unsafe within the sense of this standard shall comply with IEC 60738 UL 1434.

*Compliance is checked by inspection and by the tests of 11.2 of this standard.*

~~For PTC-S THERMISTORS whose power dissipation exceeds 15 W for the rated zero-power resistance at an ambient temperature of 25°C, the encapsulation or tubing shall comply with the flammability category FV 1 or better according to IEC 60707.~~

*Compliance is checked according to IEC 60707 or according to clause G.1.2 of annex G.*

### 14.5.4 DC Protective devices not mentioned in 14.5.1, 14.5.2, or 14.5.3

Such protective devices, for example fusing resistors fuse-links not standardized in IEC 60127 or miniature circuit breakers, shall have adequate breaking capacity and comply with UL 873, UL 1416, UL 1417, or UL 2111 as applicable.

For non-resettable protective devices, such as fuse-links, a marking shall be located close to the protective device, so that correct replacement is possible.

*Compliance is checked by inspection and during the tests under fault conditions (see 11.2).*

*The test under fault condition is carried out three times.*

*No failure is allowed.*

## 14.6 Switches

**14.6.1** PERMANENTLY CONNECTED APPARATUS shall be provided with an ALL-POLE MAINS SWITCH, except when the requirement of 5.4.2 is met.

The ALL-POLES MAINS SWITCH shall have a contact separation of at least 3 mm in each pole.

~~**14.6.2** DU Apparatus, which under normal operating conditions has a power consumption exceeding 15 W and/or employs a peak voltage exceeding 4 kV, shall be provided with a MANUALLY OPERATED MECHANICAL SWITCH.~~

~~The switch shall be so connected that, when it is in the off-position, the power consumption of circuits remaining under voltage does not exceed 15 W and/or peak voltages do not exceed 4 kV under normal operating conditions and under fault conditions according to 4.3.~~

~~The switch shall be so placed that it is readily operable by the USER but shall not be fitted in the MAINS flexible cable or cord.~~

~~Irrespective of their power consumption, no switch is required for apparatus or parts of apparatus having independent functions and not employing voltages exceeding 4 kV (peak) under normal operating conditions, provided that~~

- ~~— they are capable of being switched on or off, or both, automatically and without human intervention at the time of switching, for example clock radios, video recorders, apparatus controlled by a data link, or~~

— they are intended for continuous operation, for example antenna amplifiers, RF converters and modulators, devices forming a part of the MAINS plug.

*Compliance is checked by inspection and by measurements.*

*The measurement under fault conditions, as specified in 4.3, are carried out 2 min after the application of a fault.*

**14.6.3 DU** On apparatus for which a MANUALLY OPERATED MECHANICAL SWITCH is located in the MAINS circuit required according to 14.6.2, the on-position of the switch shall be indicated.

NOTE – The indication of the on-position may be in the form of marking, illumination, audible indication or other suitable means.

Where the indication is in the form of marking, the relevant requirements of clause 5 shall be complied with.

Marking of the off-position by the relevant symbol  $\text{O}$  (60417-2-IEC 5008) is permitted only for ALL-POLE MAINS SWITCHES.

Where marking, signal lamps or similar means might give the impression that the apparatus is completely switched-off from the MAINS, information which states clearly the correct situation shall be included in the instructions for use. If symbols are used, their meaning shall also be explained.

*Compliance is checked by inspection.*

**14.6.4 DU** Apparatus which can be brought into operation from a STAND-BY mode and where a MANUALLY OPERATED MECHANICAL SWITCH is required in accordance with 14.6.2, shall be provided with an indication to show the STAND-BY mode.

NOTE – The indication of the STAND-BY mode may be in the form of marking, illumination, audible indication or other suitable means.

No indication is required, if the current consumption of the apparatus in the STAND-BY mode does not exceed 0.7 mA (peak) a.c. or d.c.

*Compliance is checked by inspection.*

**14.6.5** Where resistors, capacitors or RC-units are used for bridging contact gaps of mechanical switches CONDUCTIVELY CONNECTED TO THE MAINS, the components shall comply with 14.1 a) or 14.2.2 respectively.

#### **14.6.6 DC DU**

NOTE – Switches controlling currents up to 0.2 A r.m.s. a.c. or d.c. need not meet any specification, provided that the voltage across the open switch contacts does not exceed 35 V (peak) a.c. or 24 V d.c.

MANUALLY OPERATED MECHANICAL SWITCHES and relays controlling currents exceeding 0.2 A r.m.s. a.c. or d.c. shall meet one of the following: comply with the requirements of UL 61058-1 or UL 508 as applicable if the voltage across the open switching contacts exceeds 35 V (peak) a.c. or 24 V d.c.

a) The switch tested as a separate component, shall comply with the requirements and tests of IEC 61058-1, whereby the following applies:

- the number of operating cycles shall be 10,000; (see IEC 61058-1, subclause 7.1.4.4);
- the switch shall be suitable for use in a normal pollution situation (see IEC 61058-1, subclause 7.1.6.2);
- the switch shall be of level 3 regarding the resistance to heat and fire (see IEC 61058-1, subclause 7.1.9.3);
- for MAINS switches the speed of contact making and breaking shall be independent of the speed of actuation (see IEC 61058-1, subclause 13.1). Moreover, MAINS switches shall comply with clause G.1.1 of annex G).

The characteristics of the switch with regard to:

- the ratings of the switch (see IEC 61058-1, clause 6);
- the classification of the switch according to:
  - nature of supply (see IEC 61058-1, subclause 7.1.1);
  - type of load to be controlled by the switch (see IEC 61058-1, subclause 7.1.2);
  - ambient air temperature (see IEC 61058-1, subclause 7.1.3);

shall be appropriate for the function of the switch under normal operating conditions.

*Compliance is checked according to test specifications of IEC 61058-1, by inspection and by measurements.*

A MAINS switch or relay shall be rated for the total RATED CURRENT CONSUMPTION of the apparatus.

A rating of a MAINS switch or relay, provided on audio apparatus intended for commercial use, is to be equal to or greater than the maximum steady state (rms) current it controls under normal operating conditions, except the audio output is adjusted to one-third maximum undistorted power output or at one-third of the manufacturer's rated output, whichever is greater.

*If the switch is a MAINS switch or relay which controls MAINS socket-outlets, the total rated current  $I$  and the peak-surge current of the socket-outlets as specified in 14.6.10 shall be taken into account for the measurement with respect to the rating.*

b) The switch tested as part of the apparatus working under normal operating conditions, shall meet the requirements of 14.6.7, 14.6.10 and 20.1.4, and moreover:

- switches controlling currents exceeding 0.2 A r.m.s. a.c. or d.c. shall meet the requirements of 14.6.8 and 14.6.9 if the voltage across the open switch contacts exceeds 35 V (peak) a.c. or 24 V d.c.;

- switches controlling currents exceeding 0.2 A r.m.s. a.c. or d.c. shall meet the requirements of 14.6.8 if the voltage across the open switch contacts does not exceed 35 V (peak) a.c. or 24 V d.c.;
- switches controlling currents up to 0.2 A r.m.s. a.c. or d.c. shall meet the requirements of 14.6.9 if the voltages across the open switch exceeds 35 V (peak) a.c. or 24 V d.c.;
- ~~MAINS~~ switches shall comply with clause G.1.1 of annex G.

**14.6.7** ~~DU~~ A switch tested according to 14.6.6 b) shall withstand, without excessive wear or other harmful effects, the electrical, thermal and mechanical stresses that occur during intended use and shall have a mechanism complying with IEC 61058-1, subclause 13.1, for d.c. switches. Moreover, for ~~MAINS~~ switches the speed of contact making and breaking shall be independent of the speed of actuation.

*Compliance is checked according to IEC 61058-1, subclause 13.1, and by the following endurance test:*

*The switch is subjected to 10,000 cycles of operation with a sequence according to IEC 61058-1, subclause 17.1.2, excluding the increased-voltage test at accelerated speed specified in IEC 61058-1, subclause 17.2.4, and under electrical and thermal conditions given by the normal operating conditions of the apparatus:*

*The test is made on three specimens, no failure is allowed.*

**14.6.8** ~~DU~~ A switch tested according to 14.6.6 b) shall be so constructed that it does not attain excessive temperatures during intended use. The materials used shall be such that the performance of the switch is not adversely affected by the operation during intended use of the apparatus. In particular, the material and design of the contacts and terminations shall be such that the operation and performance of the switch is not adversely affected by their oxidation or other deterioration.

*Compliance is checked in the on-position under normal operating conditions and according to IEC 61058-1, subclause 16.2.2 d), l) and m), taking into account the total rated current I of ~~MAINS~~ socket-outlets, if any, including the peak surge current according to 14.6.10.*

*The temperature rise at the terminations shall not exceed 55 K during this test.*

**14.6.9** ~~DU~~ A switch tested according to 14.6.6 b) shall have adequate dielectric strength.

*Compliance is checked by the following tests:*

*The switch shall withstand a dielectric strength test as specified in 10.3, without being previously subjected to the humidity treatment, the test voltage being decreased to 75% of the corresponding test voltage specified in 10.3, but not less than 500 V r.m.s. (700 V peak):*

*— The test voltage is applied in the on-position between ~~HAZARDOUS LIVE~~ parts and ~~ACCESSIBLE~~ conductive parts or parts, which are connected to ~~ACCESSIBLE~~ conductive parts, and in addition between the poles in case of a multipole switch.*

*— The test voltage is applied in the off-position across each contact gap. During the test, resistors, capacitors and RC-units in parallel to a contact gap may be disconnected.*

**14.6.10** ~~DU~~ *If the switch is a MAINS switch which controls MAINS socket-outlets, the endurance test is carried out with an additional load connected to the socket-outlets, consisting of the circuit shown in IEC 61058-1, figure 9, taking into account IEC 61058-1, figure 10.*

*The total rated current of the additional load shall correspond to the marking of the socket-outlets, see 5.2 e). The peak surge current of the additional load shall have a value as shown in table 6:*

*If the socket-outlets are marked with the currents which may be drawn, these values are chosen for the total rated current of the socket-outlets:*

*If the socket-outlets are marked with the powers which may be drawn, the total rated current of the socket-outlets is calculated from these values:*

After the test, the switch shall show no damage in the sense of this standard. In particular, it shall show no deterioration of its enclosure, no reduction of CLEARANCES and CREEPAGE DISTANCES and no loosening of electrical connections or mechanical fixings:

Compliance is checked by inspection and by the tests specified in 14.6.8 and/or 14.6.9 in the given order.

**Table 6 DU – Peak surge current**

Total-rated current of the switch-controlled socket-outlets A	Peak surge current A
Up to and including 0.5	20
Over 0.5 up to and including 1.0	50
Over 1.0 up to and including 2.5	100
Over 2.5	150

**14.6.11** ~~DU~~ A MAINS switch provided on audio apparatus intended for household use and on all video apparatus shall comply with (a), (b) or (c), and a switch that controls a MAINS connected receptacle shall comply with (b) below. The contacts of a MAINS relay shall comply with (a), (b) or (d), and the contacts of a relay that controls a MAINS connected receptacle shall comply with (b) or (d) below.

a) Satisfy the following equation for maximum current controlled by a non-TV-rated switch:

$$I_p \leq 1.414 A$$

in which:

$I_p$  is the peak inrush current controlled by the switch or relay, as determined by 14.6.11.1, and

A is the switch or relay rms current rating in amperes.

b) Be TV-rated unless it is a keylock MAINS switch used in series with a MAINS on-off switch in a commercial apparatus.

c) Be located on the back of the apparatus and is not operable from a remote control

d) Comply with the test in 14.6.11.2



**14.6.11.1 DU** The apparatus is to be connected to a rated supply source calibrated to represent a 20-A household branch circuit having a momentary 1000-A short-circuit current capability.

The controls and switches are to be adjusted as indicated in clause 7 and the thermal state of the apparatus is to maximize the magnitude of the inrush current.

The test circuit to which the apparatus is connected is to be momentarily energized by operating the test-circuit control switch asynchronously for 60 – 100 cycles of closure and opening. The waveforms of these events are to be displayed on a storage oscilloscope connected across a 0.02-ohm, high frequency resistive shunt.

Note: See annex Q for information concerning the 0.02 ohm resistor.

The peak inrush current is to be calculated according to the equation:

$$I_p = E_p / R_s$$

in which:

$I_p$  is the calculated peak inrush current of the apparatus being tested.

$E_p$  is the maximum value of voltage measured across the 0.02-ohm high-frequency resistive shunt as displayed by the storage oscilloscope, provided that the voltage waveform has a duration of at least 100 microseconds and

$R_s$  is the exact resistance of the high-frequency resistive shunt.

**14.6.11.2 DU** A relay shall be subjected to 25,000 cycles of operation making and breaking the maximum steady-state (rms) current based on the input current and the marked receptacle rating, as appropriate. A tungsten load is to be connected to the receptacle for the test.

During the test, exposed dead metal parts of the apparatus are to be connected to earth through a 1-ampere plug fuse, and the connection is to be such that any single-pole, current-interrupting device is located in the ungrounded conductor of the supply mains. When the apparatus is intended for use on direct current, or on direct current as well as alternating current, the exposed dead metal parts of the apparatus are to be connected so as to be positive with regard to a single-pole current-interrupting control device. The device is to be operated at a rate of no more than 10 cycles per minute. Electrical or mechanical breakdown of the control device, undue burning or pitting of the contacts, or opening of the fuse in the earthing connection shall not occur.

**14.6.12 DU** A double-pole switch controlling two different circuits shall be suitable for the application. The current, frequency, and voltage rating for each pole shall not be less than the maximum steady-state current, frequency, and voltage that it controls.

A double-pole switch controlling one ac circuit and one dc circuit is capable of being used without further tests when:

- a) The dc circuit voltage is 60 V or less,
- b) The dc circuit power capability is 50 W or less, and

c) The dc current is 10% or less of the ac current rating of the switch.

#### 14.7 DU SAFETY INTERLOCKS

SAFETY INTERLOCKS shall be provided where access BY HAND is possible to areas presenting hazards in the sense of this standard.

For requirements and test specifications reference is made to IEC 60950, subclause 2.8 except that the jointed test finger referred to in 9.1.1 is used to determine accessibility (IEC 60950, 2.8.2) and interlock operation (IEC 60950, 2.8.3).

#### 14.8 Voltage setting devices and the like

The apparatus shall be so constructed that changing the setting from one voltage to another or from one nature of supply to another is unlikely to occur accidentally.

*Compliance is checked by inspection and by manual test.*

NOTE – Changing of the setting which necessitates consecutive movements BY HAND is deemed to comply with this requirement.

#### 14.9 Motors

14.9.1 Motors shall be so constructed as to prevent, in prolonged intended use, any electrical or mechanical failure impairing compliance with this standard. The insulation shall not be affected and contacts and connections shall be such that they do not work loose by heating, vibration, etc.

*Compliance is checked by the following tests carried out on the apparatus under normal operating conditions.*

*a) The apparatus is connected to 1.06 times the RATED SUPPLY VOLTAGE and to 0.9 times the RATED SUPPLY VOLTAGE, each time for 48 h. Motors for short-time or intermittent operation are connected for periods in accordance with the operating time if limited by the construction of the apparatus.*

*In case of short-time operation, suitable cooling intervals are inserted.*

NOTE 1 – It may be convenient to carry out this test immediately after the test of 7.1.

*b) The motor is started 50 times while the apparatus is connected to 1.06 times the RATED SUPPLY VOLTAGE and 50 times while connected to 0.9 times the RATED SUPPLY VOLTAGE, each period of connection being at least 10 times the period from start to full speed, but not less than 10 s.*

*The intervals between starts shall be not less than three times the period of connection.*

*If the apparatus provides for more than one speed, the test is carried out at the most unfavourable speed.*

*After these tests, the motor shall withstand the dielectric strength of 10.3, no connection shall have loosened and there shall be no deterioration impairing the safety.*

NOTE 2 – For induction motors with power supplied to the stator only, see also 14.3.2.

**14.9.2** Motors shall be so constructed or mounted that wiring, windings, commutators, slip-rings, insulations, etc., are not adversely affected by oil, grease or other substances to which they are exposed during intended use.

*Compliance is checked by inspection.*

**14.9.3** Moving parts liable to cause personal injury shall be so arranged or enclosed as to provide adequate protection against this danger during intended use. Protective enclosures, guards and the like shall have adequate mechanical strength. They shall not be removable BY HAND.

*Compliance is checked by inspection and by manual test.*

**14.9.4** For motors having phase-shifting capacitors, three-phase motors and series motors, IEC 60950, annex B, clauses B.8, B.9 and B.10, apply additionally.

## **14.10 Batteries**

**14.10.1** Batteries shall be so mounted that there is no risk of the accumulation of flammable gases and that the leakage of liquid cannot impair any insulation.

*Compliance is checked by inspection.*

**14.10.2** If it is possible for the USER to replace rechargeable batteries, which can be recharged in the apparatus, by non-rechargeable batteries, special means, such as a separate charging contact on a rechargeable special battery-pack, shall be provided to avoid any current being supplied into the non-rechargeable batteries.

This requirement does not apply to batteries inside the apparatus, the replacement of which by the USER is not intended, for example batteries for memories.

*Compliance is checked by inspection.*

NOTE – Additional requirements regarding the instructions for use are given in 5.4.1.

**14.10.3** Under normal operating conditions and under fault conditions:

- for rechargeable batteries neither the charging current nor the charging time,
- for lithium batteries neither the discharging current nor the reverse current,

shall exceed the permissible values given by the battery manufacturer.

*Compliance is checked by measurement.*

*Lithium batteries shall be removed from the circuit and replaced by a short-circuit when measuring currents.*

**14.10.4** DU An apparatus intended for use with an external battery shall be provided with an overcurrent protective device in the battery-supply circuit.

The overcurrent protective device shall be in the battery connecting means (such as a connector plug) or in the lead wire not more than 15 cm from the battery connector.

#### **14.10.5 DU Battery temperature stability**

A fully rechargeable battery provided with the apparatus shall withstand the test described in 12.1.5 without release of corrosive material.

#### **14.10.6 DU Battery drop**

Each of three samples of a fully rechargeable battery provided with an apparatus is to be subjected to a single drop through a distance of 1 m to strike a hardwood surface as described in 12.1.4 without resulting in leakage of the electrolyte.

#### **14.11 DC Optocouplers**

Optocouplers shall comply with the constructional requirements of clause 8 and comply with the requirements in UL 1577.

Optocouplers bridging REINFORCED INSULATION shall comply with the applicable requirements for double protected optocouplers as specified in UL 1577.

Internal and external CLEARANCES and CREEPAGE DISTANCES of optocouplers shall comply with 13.1.1.

NOTE – The internal boundaries are not considered to be reliable joints.

### **15 TERMINALS**

#### **15.1 Plugs and sockets**

**15.1.1 DC DR DU** Plugs and appliance couplers for the connection of the apparatus to the MAINS and socket-outlets and interconnection couplers for providing MAINS power to other apparatus shall comply with the relevant IEC UL standards for plugs and socket-outlets, appliance couplers or interconnection couplers. The attachment plug shall have a current rating no lower than 125% of the current drawn by the apparatus under normal operating conditions and a voltage rating appropriate for the rated voltage for the apparatus. When the apparatus is capable of being adapted for use on two or more different supply voltages by means of an input selector, the attachment plug provided with the apparatus shall be rated for the voltage for which the apparatus is intended to be connected when it is shipped from the factory.

The attachment plug cap shall be a polarized type when the apparatus is provided with a manually operated, line connected, single-pole switch for apparatus on-off operation; an Edison-base lampholder; or a 15- or 20-ampere socket-outlet.

The identified grounded circuit conductor (neutral) shall be connected to the screw shell of the lampholder and/or to the wide blade of a socket outlet. A manually operated, line connected, single-pole on-off switch shall not be connected to the identified grounded circuit conductor.

Examples of the relevant IEC publications are: IEC 60083 [1], IEC 60320, IEC 60884, and IEC 60906.

NOTE 1 – In Australia, Denmark, Japan, New Zealand, South Africa, Switzerland and the United Kingdom, special national conditions are valid for plugs and socket-outlets.

NOTE 2 – In South Africa, where a cordset is used as the means of connection to the supply MAINS, this cordset may be provided with a rewirable plug, provided that the plug complies with the national regulations.

MAINS socket-outlets and interconnection couplers mounted on CLASS II apparatus shall only permit connection of other CLASS II apparatus.

MAINS socket-outlets and interconnection couplers mounted on CLASS I apparatus shall either allow connection of CLASS II apparatus only or shall be provided with protective earth contacts which are reliably connected to the PROTECTIVE EARTH TERMINAL or contact of the apparatus.

NOTE 3 – For CLASS I apparatus, provision for both kinds of socket-outlets and interconnection couplers is allowed on the same apparatus.

NOTE 4 – Socket-outlets allowing only the connection of CLASS II apparatus can be designed, for instance, similar to IEC 60906-1, standard sheets 3-1 or 3-2, or according to IEC 60320-2-2, standard sheets D or H.

For apparatus with socket-outlets providing MAINS power to other apparatus, measures shall be taken to ensure that plugs or appliance inlets for the connection of the apparatus to the MAINS cannot be overloaded, if the rated current of the plug or appliance connector is less than 16 A.

NOTE 5 – Marking of the socket-outlets is not considered to be a suitable measure to prevent overloading.

Internal wiring of socket-outlets providing MAINS power to other apparatus shall have a nominal cross-sectional area as specified in 16.2 for external flexible cords.

*Compliance is checked according to the relevant standards, by inspection and according to 16.2.*

**15.1.2 DU** Connectors other than for connecting MAINS power, shall be so designed that the plug has such a shape that insertion into a MAINS socket-outlet or appliance coupler is unlikely to occur.

NOTE – Examples of connectors meeting this requirement are those constructed according to IEC 60130-2, IEC 60130-8, IEC 60130-9 [2], IEC 60169-2 or IEC 60169-3 [3], when used as prescribed. An example of a connector not meeting the requirements of this subclause is the so-called “Banana” plug.

Sockets for audio and video circuits of LOAD TRANSDUCERS indicated with the symbol of 5.2 b) shall be so designed, that a plug for antenna and earth, for audio and video circuits of LOAD TRANSDUCERS and SOURCE TRANSDUCERS and for data and similar circuits which are not indicated with the symbol of 5.2 b), cannot be inserted into them.

*Compliance is checked by inspection.*

**15.1.3** TERMINALS and connectors used in output circuits of SUPPLY APPARATUS, whose output voltage is not a standard nominal MAINS voltage according to IEC 60038, table I, shall not be compatible with those specified for household and similar general purposes, for example those described in IEC 60083 [1], IEC 60320, IEC 60884, IEC 60906.

*Compliance is checked by inspection and by manual tests.*

The TERMINAL or connector shall be designed for the loading which may appear under normal operating conditions and during intended use.

*Compliance is checked according to IEC 60320 as far as safety is concerned, for instance with regard to shock hazard and heating.*

**15.1.3.1 DR** An AUDIO AMPLIFIER having an open-circuit audio output voltage not limited to 100 V that is permanently connected to the MAINS shall be provided with a means for connection complying with L.21.1.1 – L.21.1.7, and wire-binding screws, No. 6-32 (3.5 mm diameter) or larger, quick-connect TERMINALS, or leads. When wire-binding screws are provided, the screws shall comply with the requirements in L.21.3.1 – L.21.3.5.

When quick-connect TERMINALS are provided, the TERMINALS shall comply with the following requirements:

- a) Male tabs shall be firmly mounted in place.
- b) Mating female connectors shall be provided with the apparatus.
- c) Strain relief that complies with 16.5, and associated installation instructions, shall be provided to prevent stress being transmitted to the TERMINALS when a disconnected terminal can contact a HAZARDOUS LIVE part or an accessible dead metal part.
- d) The installation instructions shall include information for assembly of a terminal to a conductor, and the utilization of strain relief as follows:
  - 1) the tool designation, if a tool is to be used during the assembly
  - 2) instruction for the preparation of conductors, such as twisting strands of conductors together before assembly,
  - 3) the size and type of wire (solid or stranded), and
  - 4) identification of the strain relief means and instruction for its use if required by c) above, and
- e) The quick connect TERMINALS shall be appropriate for the use with the size and type (solid or stranded) of wire specified.

**15.1.3.2 DR** An AUDIO AMPLIFIER having an open-circuit audio output voltage not limited to 100 V that is connected to the MAINS by means of a flexible cord shall be provided with one of the following:

- a) A length of permanently attached Type SPT-2, NISPT-2, SV, SJ flexible cord or the equivalent, and an appliance coupler. The cord shall be provided with strain relief and a bushing complying with the requirements in 16.3 – 16.5, or
- b) An opening that permits the field installation of a flexible cord and wire-binding screws, quick connect TERMINALS or leads as described in 15.1.3.1. Such an opening shall be provided with an insulating bushing as described in 16.5, or
- c) A receptacle for plug-in connections.

## **15.2 DR Provisions for protective earthing**

ACCESSIBLE conductive parts of CLASS I apparatus, which might assume a hazardous voltage in the event of a single insulation fault in BASIC INSULATION, and the protective earth contacts of socket-outlets shall be reliably connected to a PROTECTIVE EARTH TERMINAL within the apparatus.

Protective earth circuits shall not contain switches or fuses.

In SUPPLY APPARATUS OF CLASS I with NON-HAZARDOUS LIVE output voltage, output circuits shall not be connected to the protective earth conductor.

The earthing conductor in a supply cord, or in an interconnecting cable shall have an equivalent or larger cross-sectional area that the current-carrying conductors in the supply cord or cable.

Protective earth conductors may be bare or insulated. If insulated, the insulation shall be green/yellow except in the following two cases:

- a) for earthing braids, the insulation shall be either green/yellow or transparent;
- b) for internal protective conductors in assemblies such as ribbon cables, busbars, flexible printed wiring, etc., any colour may be used provided that no misinterpretation of the use of the conductor is likely to arise.

Wires identified by the colour combination green/yellow shall be used only for protective earth connections.

FOR PERMANENTLY CONNECTED APPARATUS and for apparatus provided with a non-detachable flexible cord or cable, a separate PROTECTIVE EARTH TERMINAL shall be used, located adjacent to the MAINS TERMINALS and shall comply with the requirements of 15.3 and, moreover, shall not serve to fix any other component.

If parts removable BY HAND have a protective earth connection, this connection shall be made before the current-carrying connections are established when placing the part in position, and the current-carrying connections shall be separated before the protective earth connection is interrupted when removing the part.

Conductive parts in contact with protective earth connections shall not be subject to significant corrosion due to electrochemical action. Combinations above the line in annex F shall be avoided.

The PROTECTIVE EARTH TERMINAL shall be resistant to significant corrosion.

NOTE 1 – Corrosion resistance may be achieved by a suitable plating or coating process.

*Compliance is checked by inspection and by reference to the table of electro-chemical potentials in annex F.*

The resistance of the connection between the PROTECTIVE EARTH TERMINAL or contact, and parts required to be connected thereto, shall not exceed 0.1  $\Omega$ .

*Compliance is checked by the following test:*

*The test shall be carried out for 1 min with a test current of 25 A a.c. or d.c. The test voltage shall not exceed 12 V.*

NOTE 2 – In Canada, a 30 A test current is used.

*The voltage drop between the PROTECTIVE EARTH TERMINAL or contact and the part to be connected thereto shall be measured and the resistance is calculated from the current and this voltage drop. The resistance of the protective earth conductor of the power supply cord shall not be included in the resistance measurement.*



NOTE 3 – Care should be taken that the contact resistance between the tip of the measuring probe and the metal part under test does not influence the test result.

### 15.3 TERMINALS for external flexible cords and for permanent connection to the MAINS supply

**15.3.1** PERMANENTLY CONNECTED APPARATUS shall be provided with TERMINALS in which connection is made by means of screws, nuts or equally effective devices, for example screwless type clamping units according to IEC 60998-2-2 or TERMINALS according to IEC 60999.

*Compliance is checked by inspection.*

*For inlet openings, reference is made to IEC 60335-1.*

**15.3.2** For apparatus with non-detachable MAINS supply cords, the connection of the individual conductors to the internal wiring of the apparatus shall be accomplished by any means that will provide a reliable electrical and mechanical connection, except that the supply conductors and the protective earthing conductor of a non-detachable MAINS cord or cable shall not be soldered directly to the conductors of a PRINTED BOARD,

Soldered, crimped and similar connections may be used for the connection of external conductors. For soldered or crimped connections, barriers shall be provided so that CLEARANCES and CREEPAGE DISTANCES cannot be reduced to less than the values specified in clause 13 should the conductor break away at a soldered joint or slip out of a crimped connection. Alternatively, the conductors shall be positioned or fixed in such a way that reliance is not placed upon the connection alone to maintain the conductors in position.

*Compliance is checked by inspection, and, in case of doubt, by applying a pull of 5 N in any direction to the connection.*

**15.3.3** Screws and nuts which clamp external MAINS supply conductors shall have a thread conforming with ISO 261 or ISO 262, or a thread comparable in pitch and mechanical strength. They shall not serve to fix any other component, except that they may also clamp internal conductors if these are so arranged that they are unlikely to be displaced when fitting the MAINS supply conductors.

NOTE – The terminations of a component (for example a switch) built into the apparatus may be used as TERMINALS for the supply of MAINS power to the apparatus, provided that they comply with the requirements of 15.3.1.

*Compliance is checked by inspection.*

**15.3.4** For the purpose of applying the requirements for MAINS supply cords:

- it is assumed that two independent fixings will not become loose at the same time;
- conductors connected by soldering are not considered to be adequately fixed unless they are held in place near to the termination, independently of the solder. However, "hooking-in" before the soldering is, in general, considered to be a suitable means for maintaining the conductors of a MAINS supply cord in position, provided that the hole through which the conductor is passed is not unduly large;
- conductors connected to TERMINALS or terminations by other means are not considered to be adequately fixed unless an additional fixing is provided near to the TERMINAL or termination; this additional fixing may clamp both the insulation and the conductor.



**15.3.5 DR** TERMINALS for external flexible cords shall allow the connection of conductors having nominal cross-sectional areas as shown in table 7.

For rated currents exceeding 16 13 A, reference is made to IEC 60950, table 13 Article 310 of the National Electrical Code, ANSI/NFPA 70.

*Compliance is checked by inspection, by measurement and by fitting cords of the smallest and largest cross-sectional areas of the appropriate range shown in table 7.*

**Table 7 DR – Nominal cross-sectional area to be accepted by TERMINALS**

RATED CURRENT CONSUMPTION of the apparatus* A	Nominal cross-sectional area mm <sup>2</sup> AWG
Up to and including <u>3 2</u> #	0.5 to 0.75 <u>20</u>
Over <u>3</u> up to and including <u>6</u>	0.75 to 1
Over <u>6 2</u> up to and including <u>10 *</u>	1 to 1.5 <u>18</u>
Over 10 up to and including <u>16 13</u> *	1.5 to 2.5 <u>16</u>
* The RATED CURRENT CONSUMPTION includes currents which can be drawn from socket-outlets providing MAINS power for other apparatus. # MAINS plug is provided with a 2 A fuse and the apparatus is not provided with a socket outlet.	

**15.3.6** TERMINALS according to 15.3.3 shall have minimum sizes as shown in table 8.

Stud TERMINALS shall be provided with washers.

For rated currents over 16 A, reference is made to IEC 60950, table 14.

*Compliance is checked by measurement and inspection.*

**Table 8 – Minimum nominal thread diameter**

RATED CURRENT CONSUMPTION of the apparatus* A	Minimum nominal thread diameter mm	
	Pillar type or stud type	Screw type
Up to and including 10	3	3.5
Over 10 up to and including 16	3.5	4
* The RATED CURRENT CONSUMPTION includes currents which can be drawn from socket-outlets providing MAINS power for other apparatus.		

**15.3.7** TERMINALS shall be so designed that they clamp the conductor between metal surfaces with sufficient contact pressure and without damage to the conductor.

TERMINALS shall be so designed or located that the conductor cannot slip out when the clamping screws or nuts are tightened.

TERMINALS shall be so fixed that, when the means of clamping the conductor is tightened or loosened:

- the TERMINAL itself does not work loose;
- internal wiring is not subjected to stress;

- CLEARANCES and CREEPAGE DISTANCES are not reduced below the values specified in clause 13.

*Compliance is checked by inspection and measurement.*

**15.3.8** TERMINALS in circuits carrying a current exceeding 0.2 A under normal operation conditions shall be so designed that contact pressure is not transmitted through insulating material other than ceramic, unless there is sufficient resiliency in the metallic parts to compensate for any possible shrinkage of the insulating material.

*Compliance is checked by inspection.*

**15.3.9** For non-detachable MAINS supply cords, each TERMINAL shall be located in proximity to its corresponding TERMINALS of different potential and to the PROTECTIVE EARTH TERMINAL, if any.

*Compliance is checked by inspection.*

TERMINALS shall be so located, guarded or insulated that, should a strand of a flexible conductor escape when the conductor is fitted, there is no risk of accidental contact between such a strand and:

- ACCESSIBLE conductive parts or conductive parts connected to them,
- conductive parts not connected to the PROTECTIVE EARTH TERMINAL and separated from ACCESSIBLE conductive parts by SUPPLEMENTARY INSULATION only.

*Compliance is checked by inspection and, unless a special cord is prepared in such a way as to prevent the escape of strands, by the following test.*

*An 8 mm length of insulation shall be removed from the end of a flexible conductor having the appropriate nominal cross-sectional area. One wire of the stranded conductor shall be left free and the other wires shall be fully inserted into, and clamped in the TERMINAL.*

*Without tearing the insulation back, the free wire shall be bent in every possible direction, but without making sharp bends round a guard.*

*If the conductor is HAZARDOUS LIVE, the free wire shall not touch any conductive part which is ACCESSIBLE or is connected to an ACCESSIBLE conductive part or, in the case of apparatus with DOUBLE INSULATION, any conductive part which is separated from ACCESSIBLE conductive parts by SUPPLEMENTARY INSULATION only.*

*If the conductor is connected to an earthing TERMINAL, the free wire shall not touch any HAZARDOUS LIVE part.*

## 15.4 Devices forming a part of the MAINS plug

**15.4.1** A device provided with pins intended to be introduced into fixed socket-outlets shall not impose undue strain on these socket-outlets.

*Compliance is checked by engaging the device, as during intended use, with the socket-outlet of a test apparatus as shown in figure 11. The balancing arm of the test apparatus pivots about a horizontal axis through the centre lines of the contact tubes of the socket-outlet at a distance of 8 mm behind the engagement face of the socket-outlet.*

*With the device not in engagement, the balancing arm is in equilibrium, the engagement face of the socket-outlet being in the vertical position.*

*After the device has been engaged, the torque to be applied to the socket-outlet to maintain its engagement face in the vertical plane is determined by the position of a weight on the balancing arm. The torque shall not exceed 0.25 Nm.*

NOTE – This test is compatible with the test described in the IEC 60884-1.

**15.4.2** The device shall comply with the standards for the dimensions of MAINS plugs.

*Compliance is checked by measurement in accordance with the relevant standard.*

NOTE – The dimensions of some types of MAINS plugs are specified in IEC 60083.

**15.4.3** The device shall have adequate mechanical strength.

*Compliance is checked by inspection and by the following tests:*

*a) The device shall be subjected to a drop test.*

*A sample of the complete device shall be subjected to three impacts that result from being dropped 1 m onto a horizontal surface in positions likely to produce the most adverse results.*

*The horizontal surface shall consist of hardwood of at least 13 mm thick, mounted on two layers of plywood each 19 mm to 20 mm thick, all supported on a concrete or equivalent non-resilient floor.*

*After the test, the specimen shall comply with the requirements of this standard, but it need not be operational.*

NOTE 1 – Small pieces may be broken off, provided that the protection against electric shock is not affected.

NOTE 2 – Distortion of pins and damage to the finish and small dents which do not reduce the CLEARANCES OR CREEPAGE DISTANCES below the values specified in clause 13, are neglected.

*b) The pins shall not turn when a torque of 0.4 Nm is applied, first in one direction for 1 min and then in the opposite direction for 1 min.*

NOTE 3 – This test is not carried out if rotation of the pins does not impair safety in the sense of this standard.

*c) A pull force as given in table 9 is applied, without jerks, for 1 min on each pin in turn, in the direction of the longitudinal axis of the pin.*

The pull force is applied within a heating cabinet at a temperature of  $(70 \pm 2)^\circ\text{C}$ , 1 h after the device has been placed in the heating cabinet.

After the test, the device is allowed to cool down to ambient temperature, no pin shall have been displaced in the body of the device by more than 1 mm.

For the purpose of this test, protective earth contacts, irrespective of their number, are considered as one pole.

Tests b) and c) are made separately, each with new samples.

**Table 9 – Pull force on pins**

Rating of the equivalent plug type	Number of poles	Pull force N
Up to and including 10 A 130/250 V	2	40
	3	50
Over 10 A up to and including 16 A 130/250 V	2	50
	3	54
Over 10 A up to and including 16A 440 V	3	54
	More than 3	70

## 16 External flexible cords

**16.1 DC DR** MAINS supply flexible cords shall be of the sheathed type complying with IEC 60227 for PVC cords or according to IEC 60245 for synthetic rubber cords UL 817, be marked VW-1 and have an ampacity not less than the current drawn by the apparatus. The specific types of flexible cords are to be as indicated in table 9A.

NOTE 1 – In Australia and New Zealand special national conditions apply for external flexible cords.

*Compliance is checked by testing MAINS supply flexible cords in accordance with IEC 60227 or IEC 60245.*

Non-detachable flexible cables and cords of CLASS I apparatus shall be provided with a green/yellow core connected to the PROTECTIVE EARTH TERMINAL of the apparatus and, if a plug is provided, to the protective earth contact of the plug.

*Compliance is checked by inspection.*

NOTE 2 – The colour code for cores of flexible MAINS cords is contained in IEC 60173 [4].

**Table 9A DU – Cords for apparatus**

<u>Apparatus type</u>	<u>Cord type</u>	<u>Cord length, m<sup>b</sup></u>
<u>Portable, table-top, floor standing and rack-mounted audio and video apparatus</u>	<u>NISPT-2<sup>a</sup>, SV, SVT, SVE, SJ, SJT, SJE</u>	<u>1.5 minimum</u>
<u>Household musical instruments</u>	<u>NISPT-2<sup>a</sup>, SV, SVT, SVE, SJ, SJT, SJE</u> <u>SJ, SJT, SJE</u>	<u>3.0 maximum</u> <u>7.5 maximum</u>
<u>Coffee table<sup>c</sup></u>	<u>SV, SVT, SVE, SJ, SJT, SJE</u>	<u>3.0 minimum</u>
<u>Undercabinet and PORTABLE APPARATUS with cord storage compartment</u>	<u>NISPT-2<sup>a</sup></u>	<u>1.5 minimum</u>
<u>Commercial amplifier-speakers, musical instruments and sound systems<sup>d</sup></u>	<u>SJ, SJT, SJE</u>	<u>7.5 maximum</u>
<sup>a</sup> May be replaced with appliance wiring material construction that has been determined to be equivalent. <sup>b</sup> The length of a flexible cord on an apparatus intended for a special installation is not prohibited from being less than specified. <sup>c</sup> A coffee-table type apparatus is a type that is finished on all four sides and intended for use in the center of the room. <sup>d</sup> A system comprised of a number of different components as may be found in a school system or language teaching system.		

**16.2 DR** Power supply cord conductors shall have a nominal cross-sectional area not less than those shown in table 10.

For higher currents, reference is made to IEC 60950, table 11 Article 400 of the National Electrical Code, ANSI/NFPA 70.

*Compliance is checked by measurement.*

NOTE – In the USA and Canada a minimum cross-sectional area of 0.81 mm<sup>2</sup> is required.

**Table 10 DR – Nominal cross-sectional areas of external flexible cords**

<u>RATED CURRENT CONSUMPTION of the apparatus<sup>1)</sup></u> <u>A</u>	<u>Normal cross-sectional area</u> <u>mm<sup>2</sup></u>
Up to and including 3	0.5 <sup>2)</sup>
Over 3 up to and including 6	0.75
Over 6 up to and including 10	1
Over 10 up to and including <del>16</del> 13	1.5
<sup>1)</sup> The RATED CURRENT CONSUMPTION includes currents which can be drawn from socket-outlets providing MAINS power for other apparatus. <sup>2)</sup> This nominal cross-sectional area is allowed only for CLASS II apparatus and provided that the length of the supply cord, measured between the point where the cord or the cord guard enters the apparatus, and the entry to the plug, does not exceed 2 m.	

**16.3 DU**

a) Flexible cords, not complying with 16.1, used as a connection between the apparatus and other apparatus used in combination with it, and comprising HAZARDOUS LIVE conductors, shall have adequate dielectric strength.

*Compliance is checked by applying the dielectric strength test using a sample of approximately 1 m length and by applying the relevant test voltage according to 10.3 for the grade of insulation under consideration as follows:*

- for insulation of a conductor: by the voltage test method given in IEC 60885-1, subclauses 3.1 and 3.2;
- for SUPPLEMENTARY INSULATION, for example sleeving around a group of conductors: between a conductor inserted into the sleeve and metal foil wrapped tightly round the sleeve for a length of at least 100 mm.

NOTE – Where a power supply cord, whose insulating properties comply with those of the cord types of 16.1, is used inside the equipment, either as an extension of the external power supply cord or as an independent cable, its sheath is considered to be adequate SUPPLEMENTARY INSULATION for the purposes of this subclause.

b) Flexible cords not complying with 16.1, used as connection between the apparatus and other apparatus used in combination with it, and comprising HAZARDOUS LIVE conductors, shall withstand bending and other mechanical stresses occurring during intended use.

*Compliance is checked by the test of IEC 60227-2, subclause 3.1, except that the table 11 applies.*

*The carrier moves to and fro 15,000 times (30,000 movements).*

*The voltage U between the conductors is the test voltage according to 10.3.*

*During and after the test, the specimen shall withstand the dielectric strength test specified in 10.3.*

c) Flexible cords not complying with 16.1, used as connection between the apparatus and other apparatus used in combination with it, and comprising HAZARDOUS LIVE conductors, shall be marked VW-1.

Flexible cords not complying with 16.1, used as connection between the apparatus and other apparatus used in combination with it, which exceed the open circuit voltage limit of 35 V (peak) a.c. or d.c. or carrying a current exceeding 0.2 A, shall be rated VW-1.

16.3 revised June 23, 2000

**Table 11 – Mass and pulley diameter for stress test**

Overall diameter of the flexible cable or cord mm	Mass kg	Pulley diameter mm
Up to and including 6	1.0	60
Over 6 up to and including 12	1.5	120
Over 12 up to and including 20	2.0	180

**16.4** Conductors of flexible cords used as a connection between the apparatus and other apparatus used in combination with it shall have a cross-sectional area such that the temperature rise of the insulation under normal operating conditions and under fault conditions is negligible.

*Compliance is checked by inspection. In case of doubt, the temperature rises of the insulation are determined under normal operating conditions and under fault conditions. The temperature rises shall not exceed the values given in the appropriate columns of table 2.*

**16.5** The apparatus shall allow the external flexible cords, comprising one or more HAZARDOUS LIVE conductors, to be so connected that the connecting points of the conductors are relieved from strain, that the outer covering is protected from abrasion, and that the conductors are prevented from twisting.

Moreover, it shall not be possible to push an external cord back into the apparatus through its aperture if this can impair safety in the sense of this standard.

The method by which the relief from strain and the prevention of twisting is provided shall be clearly seen.

Makeshift methods, such as tying the cord into a knot or tying the cord with a string, are not permitted.

The devices for strain and twist relief shall either be made of insulating material, or have a fixed covering of insulating material other than natural rubber, if an insulation fault of the cord may make ACCESSIBLE conductive parts HAZARDOUS LIVE.

For CLASS I apparatus, the arrangement of the TERMINALS for the MAINS supply flexible cord, or the length of the conductors between the device for strain and twist relief and the TERMINALS, shall be such that the HAZARDOUS LIVE conductors become taut before the conductor connected to the PROTECTIVE EARTH TERMINAL, if the cord slips out of the device for strain and twist relief.

*Compliance is checked by inspection and by the following test.*

*The test is made with the type of flexible cord attached to the apparatus.*

*The apparatus is fitted with its flexible cord, the device for strain and twist relief being appropriately used. The conductors are introduced into the TERMINALS, and the TERMINAL screws, if any, are slightly tightened, so that the conductors cannot easily change their position.*

*After this preparation, pushing the cord further into the apparatus shall not be possible or shall cause no hazard in the sense of this standard.*

*A mark is made on the cord, under strain, near the aperture, and the flexible cord is subjected 100 times to a pull of 40 N for a duration of 1 s each. The pull shall not be applied in jerks.*

*Immediately afterwards, the cord is subjected for a period of 1 min to a torque of 0.25 Nm.*

*During the test, the cord shall not be displaced by more than 2 mm, the measurement being made while the cord is still under strain. The ends of the conductors shall not be noticeably displaced in the TERMINALS and no damage to the flexible cord shall be caused by the device for strain and twist relief.*

**16.6** Apertures for external flexible cords mentioned in 16.5 shall be so constructed that there is no risk of damage to the cord during its introduction or subsequent movement.

NOTE – This can be done, for example, by rounding the edges of the aperture or by using an appropriate bushing of insulating material.

*Compliance is checked by inspection and by fitting flexible cords.*

**16.7** TRANSPORTABLE APPARATUS, being musical instruments and their associated amplifiers, shall have an appliance inlet according to IEC 60320-1 for connection to the MAINS by detachable cord sets or shall have a means of stowage to protect the MAINS cord when not in use, for example a compartment, hooks or pegs.

*Compliance is checked by inspection.*

## 17 Electrical connections and mechanical fixings

**17.1** Screw TERMINALS providing electrical contact and screw fixings which during the life of the apparatus will be loosened and tightened several times shall have adequate strength.

Screws exerting contact pressure and screws with a nominal diameter less than 3 mm which form part of the above-mentioned screw fixings shall screw into a metal nut or a metal insert.

However, screws having a nominal diameter less than 3 mm, which do not exert contact pressure, need not be screwed into metal, provided that the screw fixing withstands the torque specified in table 12 for screws of 3 mm diameter.

Screw fixings which during the life of the apparatus will be loosened and tightened several times include TERMINAL screws, screws for fixing covers (as far as they must be loosened to open the apparatus), screws for fixing handles, knobs, legs, stands and the like.

*Compliance is checked by the following test.*

*The screws are loosened and then tightened, with a torque according to table 12:*

- 5 times in the case of screws operating in a thread in metal;*
- 10 times in the case of screws operating in wood, WOOD-BASED MATERIAL or in a thread in insulating material.*

*In the latter case, the screws are to be completely removed and reinserted each time.*

*The screws shall not be tightened in jerks.*

*After the test, there shall be no deterioration impairing safety in the sense of this standard.*

*The material in which the screws are inserted is verified by inspection.*

*The test is made by means of a suitable test screwdriver, spanner or key, applying a torque as shown in table 12, the appropriate column being:*



- for metal screws without heads, if the screw, when tightened, does not protrude from the hole: **I**
- for other metal screws and for nuts: **II**
- for screws of insulating material:
  - having a hexagonal head with the dimension across flats exceeding the overall thread diameter, or
  - with a cylindrical head and a socket for a key, the socket having a dimension across flats not less than 0.83 times the overall thread diameter, or
  - with a head having a slot or cross slots, the length of which exceeds 1.5 times the overall thread diameter: **III**
- for other screws of insulating material: **III**

**Table 12 – Torque to be applied to screws**

Nominal diameter of screw mm	Torque Nm		
	I	II	III
Up to and including 2.8	0.2	0.4	0.4
Over 2.8 up to and including 3.0	0.25	0.5	0.5
Over 3.0 up to and including 3.2	0.3	0.6	0.6
Over 3.2 up to and including 3.6	0.4	0.8	0.6
Over 3.6 up to and including 4.1	0.7	1.2	0.6
Over 4.1 up to and including 4.7	0.8	1.8	0.9
Over 4.7 up to and including 5.3	0.8	2.0	1.0
Over 5.3 up to and including 6.0	–	2.5	1.25

**17.2** Means shall be provided to ensure the correct introduction of screws into female threads in non-metallic material, if they will be loosened and tightened several times during the life of the apparatus and contribute to safety in the sense of this standard.

*Compliance is checked by inspection and by manual test.*

NOTE – This requirement is deemed to be met if introduction in a slanting manner is prevented, for example by guiding the screw in the part to be fixed by a recess in the nut or a lead to the screw.

**17.3** Screws or other fixing devices intended to fix back covers, bottom covers, legs, stands or the like, shall be captive in order to prevent replacement during servicing by screws or other fixing devices, which might cause a reduction of CLEARANCES OR CREEPAGE DISTANCES between ACCESSIBLE conductive parts or parts connected to them and HAZARDOUS LIVE parts below the values given in clause 13.

Such screws need not be captive if, when replaced by screws having the same nominal diameter and a length of 10 times its nominal diameter, the distances are not less than those stated in clause 13.

*Compliance is checked by inspection and measurement.*

**17.4** Conductive parts permanently fixed together and carrying a current exceeding 0.2 A across their interface under normal operating conditions shall be secured in such a way that loosening is prevented.

*Compliance is checked by inspection and by manual test.*

NOTE 1 – Sealing by compound or the like provides satisfactory locking only for screw connections not subject to torsion.

NOTE 2 – If the fixing consists of more than one screw or rivet, only one of them need be locked.

NOTE 3 – For rivets, a non-circular shank or an appropriate notch may be a sufficient guard against rotation.

**17.5** Electrical connections in circuits carrying a current exceeding 0.2 A under normal operation conditions shall be so designed that contact pressure is not transmitted through insulating material other than ceramic, unless there is sufficient resiliency in the metallic parts to compensate for any possible shrinkage of the insulating material.

*Compliance is checked by inspection*

**17.6** Stranded conductors of flexible supply cords carrying a current exceeding 0.2 A under normal operating conditions, which are connected to SCREW TERMINALS, shall not be consolidated by lead-tin soldering where they are subject to contact pressure, unless the clamping means is so designed that there is no risk of a bad contact due to cold flow of the solder.

*Compliance is checked by inspection.*

**17.7** Cover-fixing devices which may be operated during the life of the apparatus, shall have adequate mechanical strength, if the failure of such devices would impair safety in the sense of this standard.

The locked and unlocked positions of these devices shall not be ambiguous, and it shall not be possible to unlock the devices inadvertently.

*Compliance is checked by inspection, by operating the device and by one of the following tests:*

– *In the case of devices the operation of which is effected by a combination of rotary and linear movements, the device is locked and unlocked and the torques or forces necessary for this operation are measured. While the device is in the locked position, a torque or force of twice the value necessary to lock the device, with a minimum of 1 Nm or 10 N is applied in the locking direction, unless it is unlocked by a smaller torque or force in the same direction.*

*This operation is performed 10 times.*

*The torque or force necessary to unlock the device shall be at least 0.1 Nm or 1 N.*

– *In the case of covers fixed by means of snap fasteners, the cover is removed and replaced 10 times in the intended way.*

*After this test the cover shall still comply with the tests by means of the rigid test finger and the test hook described in 9.1.7 a) and b).*

**17.8 DU** Detachable legs or stands, casters, brackets and similar objects supplied by the manufacturer of the apparatus shall be delivered with the relevant fixing means and suitable assembly instructions.

Relevant fixing means are not required when installation is to be done by a SKILLED PERSON.

*Compliance is checked by inspection.*

**17.9** Internal pluggable connections shall be so designed that unintended loosening is unlikely, if the loosening can impair the safety in the sense of this standard.

*Compliance is checked by inspection and in case of doubt by applying a pull of 2 N in any direction to the connection.*

NOTE – For other internal connections see 8.11.

**17.10 DU** Aluminum conductors, insulated or uninsulated, used as internal wiring, such as for interconnection between current carrying parts or as transformer windings, shall be terminated by a method capable of being used in the combination of metals involved at the connection point.

**17.11 DU** An ACCESSORY shall be investigated to determine that:

a) the ACCESSORY, and the combination of the ACCESSORY and the apparatus shall present no hazard in the sense of this standard and

b) the ACCESSORY is provided with installation instructions.

**17.11.1 DU** The installation of an ACCESSORY by a SKILLED PERSON shall be such that:

a) The mechanical positioning is accomplished by means of tools normally available or by means of special tools provided by the organization responsible for providing the apparatus as part of the installation kit, and

b) the electrical connections are made by using existing TERMINALS and connections in the apparatus or the building wiring.

## **18 DU Mechanical strength of picture tubes and protection against the effects of implosion**

A bulb of a picture tube having a face diameter of 7.5 cm or more shall be mounted in an enclosure. The enclosure shall have no opening that exceeds 130 mm<sup>2</sup> unless the minor dimension of the opening is 10 mm or less.

**18.1 DU** Picture tubes with a maximum face dimension exceeding 46 7.5 cm either shall be intrinsically protected with respect to effects of implosion and to mechanical impact, or the enclosure of the apparatus shall provide adequate protection against the effects of an implosion of the tube.

A non-intrinsically protected picture tube shall be provided with an effective protective screen which cannot be removed BY HAND or be totally enclosed, including the face, in an enclosure as described above. If a separate screen of glass is used, it shall not be in contact with the surface of the tube.

*Compliance is checked by inspection, by measurement, and by the tests of:*

- 18.2 for intrinsically protected tubes, including those having integral protective screens;

– 18.3 for apparatus having non-intrinsically protected tubes.

NOTE 1 – A picture tube is considered to be intrinsically protected with respect to the effects of implosion if, when it is correctly mounted, no additional protection is necessary.

NOTE 2 – To facilitate the tests, the tube manufacturer may indicate the most vulnerable area on the tubes to be tested.

## 18.2 DC Intrinsically protected picture tubes, including those having integral protective screens

*Each of the tests of 18.2.2 and 18.2.3 is made on six tubes, three of which are tested as received and the others after having been subjected to the ageing process of 18.2.1.*

*No failure is allowed.*

*For the tests of 18.2.2 and 18.2.3, the tubes are mounted in a test cabinet, according to the instructions given by the manufacturer of the tube, the cabinet being placed on a horizontal support at a height of (75 ±5) cm above the floor.*

*Care is taken that, during the tests, the cabinet does not slide on the support.*

NOTE – The following description of a test cabinet is given as an example:

– the cabinet is made of plywood, with a thickness of about 12 mm for tubes having a maximum face dimension not exceeding 50 cm and of about 19 mm for larger tubes;

– the outside dimensions of the cabinet are approximately 25% larger than the overall dimensions of the tube;

– the front of the cabinet is provided with an opening closely surrounding the tube when mounted. The back of the cabinet is provided with an opening, 5 cm in diameter, and rests against a wooden bar, about 25 mm high, which is fixed to the support and prevents the cabinet from sliding.

Picture tubes employing integral implosion protection shall comply with UL 1418.

### 18.2.1 DU Ageing process

*The ageing processes is as follows:*

*a) Damp heat conditioning:*

*24 h at (25 ±2)°C and 90% to 95% relative humidity*

*24 h at (45 ±2)°C and 75% to 80% relative humidity*

*24 h at (25 ±2)°C and 90% to 95% relative humidity*

*b) Change of temperature consisting of two cycles, each comprising:*

*1 h at (+20 ±2)°C*

*1 h at (-25 ±2)°C*

*1 h at (+20 ±2)°C*

*1 h at (+50 ±2)°C*

NOTE — The change of temperature is not intended to cause severe thermal stress on the picture tube, and may be achieved using one or two chambers.

*c) Damp heat conditioning as indicated under a).*

### **18.2.2 DU Implosion test**

*Cracks are propagated in the envelope of each tube by the following method:*

*An area on the side or on the face of each tube is scratched (see figure 12) with a diamond stylus and this place is repeatedly cooled with liquid nitrogen or the like until a fracture occurs. To prevent the cooling liquid from flowing away from the test area, a dam of modelling clay or the like should be used.*

*After this test, no particles having a mass exceeding 2 g shall have passed a 25 cm high barrier placed on the floor 50 cm from the projection of the front of the tube and no particles shall have passed a similar barrier at 200 cm.*

### **18.2.3 DU Mechanical strength test**

*Each tube is subjected to one impact of a hardened steel ball having a Rockwell hardness of at least R62 and a diameter of 40 (+1, 0) mm, and which is suspended from a fixed point by means of a string.*

*Keeping the string straight, the ball is raised and then allowed to fall onto any place on the face of the tube from a height such that the vertical distance between the ball and the point of impact is:*

- 210 cm for tubes having a maximum face dimension exceeding 40 cm;*
- 170 cm for other tubes.*

*The point of impact on the face of the tube shall be at least 20 mm from the border of its useful area.*

*After this test, no particles having a mass exceeding 10 g shall have passed a 25 cm high barrier, placed on the floor, 150 cm from the projection of the front of the tube.*

### **18.3 DU Non-intrinsically protected picture tubes**

*The apparatus, with the picture tube and in the apparatus with the protective screen in position, if provided, is placed on a horizontal support at a height of  $(75 \pm 5)$  cm above the floor, or directly on the floor if the apparatus is obviously intended to be positioned on the floor to be subjected to the thermal shock method of inducing an implosion as described in UL 1418. If an implosion is not capable of being induced by the thermal shock method, the high energy method described in UL 1418 is to be used.*

*The tube is made to implode inside the enclosure of the apparatus by the method described in 18.2.2.*

*After this test, no particles having a mass exceeding 2 g shall have passed a 25 cm high barrier, placed on the floor, 50 cm from the projection of the front of the apparatus, and no particle shall have passed a similar barrier at 200 cm.*

Compliance is checked by the applicable requirements in UL 1418.

## 19 DU Stability and mechanical hazards

Revised 19 effective January 31, 2003

Apparatus having a mass exceeding 18 kg or an apparatus with a CRT having a diagonal dimension of 48 cm or greater shall have adequate stability.

In addition, the stability shall be ensured when legs or stands supplied by the manufacturer are fitted.

*Compliance is checked by the tests of 19.1, and 19.2, 19.2.1 and 19.2.2.*

*During the tests in 19.1, 19.2 and 19.2.1, the apparatus shall not overbalance and during the test in 19.2.2 the apparatus shall not slide.*

**19.1 DU** *The apparatus is placed in its intended position of use on a plane, inclined at an angle at 10° to the horizontal. All doors, drawers, casters, wheels, adjustable feet (levelers) and other appurtenances of the apparatus are positioned in any combination that results in the least stability. Legs and other means shall be blocked to keep the apparatus from sliding. The apparatus is and then rotated slowly through an angle of 360° about its normal vertical axis.*

*If, however, the apparatus is such that, were it to be tilted through an angle of 10° when standing on a horizontal plane, a part of it not normally in contact with the supporting surface would touch the horizontal plane, the apparatus is placed on a horizontal support and tilted in the most unfavourable direction through an angle of 10°.*

NOTE – The test on the horizontal support may be necessary, for example, for apparatus provided with small feet, castors or the like.

Revised 19.1 effective January 31, 2003

**19.2 DU** *The apparatus is placed in its intended position of use on a non-skid surface that is at an angle not exceeding 1° to the horizontal with lids, flaps, drawers, and doors, casters, wheels, adjustable feet (levelers) and other appurtenances in the most unfavourable position.*

*A force of 100 N directed vertically downwards is applied in such a way as to produce the maximum overturning moment, to any point of any horizontal surface, protrusion or recess, provided that the distance of that point to the non-skid surface does not exceed 75 cm.*

**19.2.1 DU** *The apparatus is placed on a non-skid surface with lids, flaps, drawers, doors, casters, wheels, adjustable feet (levelers) and other appurtenances in the most unfavorable position.*

*A force of 60 N is directed horizontally in such a way as to produce the maximum overturning moment to any point on the apparatus not exceeding 150 cm above the non-skid surface.*

*For an apparatus having a mass of 25 kg or more, a force of 90 N or 13% of the weight of the apparatus, whichever is less, is directed horizontally in such a way as to produce the maximum overturning moment at any point on the apparatus, provided that the distance of that point to the floor does not exceed 150 cm.*

Revised 19.2.1 effective January 31, 2003

**19.2.2 DU** A table-top apparatus with a CRT or other type viewing screen having a diagonal dimension of 48 cm or greater is placed on a clean, dry, glass covered horizontal surface such that only the supporting feet are in contact with the glass. The glass covered surface is then tilted in the most unfavourable direction through an angle of 10 degrees

Added 19.2.2 effective January 31, 2003

**19.3** Edges or corners, except those required for proper apparatus functioning, shall be smoothed (no abrupt discontinuity) when they could otherwise be hazardous to the USER because of location or application in the apparatus.

*Compliance is checked by inspection.*

No Text on This Page



**19.4** Glass, with the exception of picture tubes, with a surface area exceeding 0.1 m<sup>2</sup> or with a major dimension exceeding 450 mm, shall not be shattered in a manner likely to result in a skin lacerating injury.

*Compliance is checked by the test of 12.1.3.*

*If thereby the glass breaks or cracks, an additional test according to 19.4.1 is made on a separate test sample.*

#### **19.4.1 Fragmentation test**

*The test sample is supported over its whole area and precautions shall be taken to ensure that particles will not be scattered upon fragmentation. Then the test sample is shattered with a centre punch placed approximately 15 mm in from the midpoint of one of the longer edges of the test sample. Within 5 min of fracture, and without using any aid to vision, except spectacles if normally worn, the particles are counted in a square of 50 mm side located approximately at the centre of the area of coarsest fracture and excluding any area within 15 mm of any edge or hole.*

*The test sample shall fragment in such a way that the number of particles counted in a square of 50 mm side shall not be less than 45.*

NOTE – A suitable method of counting the particles is to place a square of 50 mm side of transparent material over the test sample and mark a spot of ink as each particle within the square is counted. To count particles at the edges of the square, select any two adjacent sides of the square and count all the particles intersected by these, exclude all other intersected particles.

#### **19.5 DU Rack mounting test**

*An apparatus provided with rack, ceiling, or other mounting provisions shall be subjected to a force four times the weight of the apparatus. There shall be no cracking, breaking, or detaching of the securing means or of the portion of the enclosure to which the mounting means are attached when tested as described below.*

*The apparatus is to be mounted as intended by fastening means provided with the unit. A weight of three times the apparatus weight is to be applied to the top of the apparatus, the center of force acting through the plane located one half the distance between the front and the rear of the apparatus. The force is to be gradually applied and maintained for 1 min.*

#### **20 DU Resistance to fire**

The apparatus shall be so designed that the start and spread of fire is prevented as far as possible, and shall not give rise to danger of fire to the surroundings of the apparatus.

This is achieved as follows:

– by using materials having a flammability rate less than cellulose nitrate.

and

– by using good engineering practice in design and production of the apparatus to avoid  
POTENTIAL IGNITION SOURCES,

and

– by using materials of low flammability for internal parts in the vicinity of POTENTIAL IGNITION SOURCES,

and

– by using FIRE ENCLOSURES to limit the spread of fire.

The requirements are considered to be fulfilled, if the apparatus complies with the requirements of 20.1 and 20.2.

NOTE 1 – It is recommended that the quantity of environmentally unfriendly flame retardant materials should be kept as low as possible in order to minimize environmental pollution.

NOTE 2 – In Australia and New Zealand special national conditions apply which include tests based on reconciliation with the philosophy of IEC 60695 [18] with respect to glow wire testing, needle flame testing, consequential testing and end product consequential testing.

### 20.1 DU Electrical components and mechanical parts

Electrical components and mechanical parts with the exception of those in a) and b), shall comply with the requirements of 20.1.1, 20.1.2, 20.1.3 and 20.1.4.

a) ~~Components that are contained in an enclosure having a flammability category of FV-0 according to IEC 60707 and having openings only for the connecting wires filling the openings completely, and for ventilation not exceeding 1 mm in width regardless of length.~~

b) The following parts which would contribute negligible fuel to a fire:

– small mechanical parts, the mass of which does not exceed 4 g, such as mounting parts, gears, cams, belts and bearings;

– small electrical components, such as capacitors with a volume not exceeding 1750 mm<sup>3</sup>, integrated circuits, transistors and optocoupler packages, if these components are mounted on material of flammability category FV-1 V-1 or better according to IEC 60707 UL 94;

– parts such as projection TV lenses, loudspeaker parts, external accessories, and fibrous materials less than 0.25 mm thick.

NOTE – In considering how to minimize propagation of fire and what "small parts" are, account should be taken of the cumulative effect of small parts adjacent to each other for the possible effect of propagating fire from one part to another.

#### 20.1.1 Electrical components

Electrical components shall comply with the relevant flammability requirement of clause 14.

Where there are no applicable flammability requirements in clause 14, the requirements of 20.1.4 apply.

*Compliance is checked by appropriate tests of clause 14 or 20.1.4.*

### 20.1.2 DC Internal wiring

Sleeving, extruded tubing and insulation on wiring shall be rated VW-1, shall not contribute to the spread of fire under following conditions:

- a) wiring located in a circuit that is considered a POTENTIAL IGNITION SOURCE working at voltages exceeding 4 kV (peak) a.c. or d.c., or
- b) wiring not located in a circuit that is a POTENTIAL IGNITION SOURCE but is in contact with wiring located in a circuit that is a POTENTIAL IGNITION SOURCE leaving an internal FIRE ENCLOSURE with the exception of insulation consisting of PVC, TFE, PTFE, FEP or neoprene.

NOTE – Reference is made to ISO 1043-1 [14] for the meaning of the abbreviations.

*Compliance is checked by the tests of clause G.2, annex G inspection.*

Tape in contact with parts of circuits that are potential ignition sources shall be flame retardant.

### 20.1.3 DC PRINTED BOARDS

Base material of PRINTED BOARDS on which the AVAILABLE POWER at a connection exceeds 15 W or the operating at a voltage exceeding exceeds 50 V and equal or less than 400 V (peak) a.c. or d.c. under normal operating conditions, shall be of flammability category FV 1 V-1 or better according to IEC 60707; unless the PRINTED BOARDS are protected by an enclosure meeting the flammability category FV 0 according to IEC 60707, or be made of metal, having openings only for connecting wires which fill the openings completely UL 94.

Base material of PRINTED BOARDS on which the AVAILABLE POWER at a connection exceeds 15 W operating at a voltage exceeding 400 V (peak) a.c. or d.c. under normal operating conditions, and base material of PRINTED BOARDS supporting spark gaps which provide protection against overvoltages, shall be of flammability category FV 0 V-0 according to IEC 60707, unless the PRINTED BOARDS are contained in a metal enclosure, having openings only for connecting wires which fill the openings completely UL 94.

*Compliance is checked for the smallest thickness of PRINTED BOARD used, in accordance with IEC 60707 or of clause G.1 of annex G after a preconditioning of 24 h at a temperature of  $(125 \pm 2)^\circ\text{C}$  in an air-circulating oven and a subsequent cooling period of 4 h at room temperature in a desiccator over anhydrous calcium chloride UL 94.*

### 20.1.4 DC DU Components and parts not covered by 20.1.1, 20.1.2, and 20.1.3 except and FIRE ENCLOSURES

20.1.4 revised June 23, 2000

Component power supplies complying with the construction requirements of UL 1950, Third Edition, are considered to fulfill the flammability requirements of this sub-clause.

When the distance between ~~POTENTIAL IGNITION SOURCES~~ and components or parts mentioned in the heading does not exceed the values specified in table 13, then these Components and parts shall comply with the relevant flammability category according to IEC 60707 UL 94 as specified in table 13. ~~unless shielded from POTENTIAL IGNITION SOURCES by a barrier made of metal or meeting the flammability category FV 0 according to IEC 60707. The barrier shall have dimensions covering at least the areas specified in table 13 and shown in figure 13.~~

A barrier shall have a distance to a POTENTIAL IGNITION SOURCE of at least 5 mm.

In case of openings in the barrier the requirements shown in figure 13 apply, unless it is not possible for the needle flame specified in IEC 60695-2-2 to penetrate the barrier.

PRINTED BOARDS carrying POTENTIAL IGNITION SOURCES are not considered to be a barrier for the purpose of this subclause.

POTENTIAL IGNITION SOURCES inside electrical components are not included in this requirement.

Wood and WOOD-BASED MATERIAL with a thickness of at least 6 mm is considered to fulfill the FV 1 requirement of this subclause.

Compliance is checked in accordance with IEC 60707 or clause G.1 of annex G for the smallest thickness used, except for flammability category FH 3-40 mm/min, in which case the test is made on test specimens with a thickness of  $(3 \pm 0.2)$  mm, irrespective of the actual thickness in the apparatus.

**Table 13 DU – Distances to POTENTIAL IGNITION SOURCES**

Open-circuit voltage of the POTENTIAL IGNITION SOURCE V	Distance from POTENTIAL IGNITION SOURCES to the components or parts downwards or sideways less than (see figure 13) mm	Distance from POTENTIAL IGNITION SOURCES to the components or parts upwards less than (see figure 13) mm	Flammability category according to IEC 60707
> 50 to ≤ 400 (peak) a.c. or d.c.	13	50	FH 3-40 mm/min
> 400 to ≤ 4000 (peak) a.c. or d.c.	13	50	FV 2
> 4000 (peak) a.c. or d.c.	D <sup>1)</sup>	D <sup>2)</sup>	FV 1

<sup>1)</sup> where D is 13 mm or the open-circuit voltage of the POTENTIAL IGNITION SOURCE in kilovolts, whichever is larger.  
<sup>2)</sup> where D is 50 mm or the open-circuit voltage of the POTENTIAL IGNITION SOURCE in kilovolts, whichever is larger.

**Table 13 DU – Flammability categories for components and parts**

Application	Flammability category <sup>a</sup>
Internal barriers for apparatus with voltages exceeding 4 kV peak	V-2, V-1, V-0, VTM-2, VTM-1, VTM-0
Polymeric or fiber parts in contact with a component located in a potential ignition source circuit	V-2, V-1, V-0, HF-2, HF-1, HF-0, VTM-2, VTM-1, VTM-0
Sound-deadening material in contact with speaker connections capable of producing greater than 240 W audio power	V-2, V-1, V-0, HF-2, HF-1, HF-0
Grille covering material, cloth, and reticulated foam	Tablet <sup>b</sup>
Polymeric and fiber materials used in applications other than those specified above	HB, V-2, V-1, V-0, HBF, HF-2, HF-1, HF-0, VTM-2, VTM-1, VTM-0

<sup>a</sup> Does not apply to the internal insulating systems of components, except for inductors and windings. See 14.3.2.

<sup>b</sup> The part is to be supported so that its thinnest outside solid surface is in a horizontal position. A tablet (Lilly tablet No. 1588 are capable of being used for this purpose) comprised of hexamethylene-tetramine (C<sub>6</sub>H<sub>12</sub>N<sub>4</sub>) having a weight of  $0.15 \pm 0.02$  gram, and having a controlled burning time of  $105 \pm 5$  seconds, is to be placed on the thinnest section of the part. The tablet is then to be ignited with a match. The tablet is to be permitted to burn until it is completely consumed and the part ceases to flame or glow. When the tablet burns through the part and falls to the surface below, the test is concluded when the part ceases to flame or glow. The part shall not burn further than 5 cm from the center of the tablet.

**20.2 Fire enclosure**

**20.2.1 DU** POTENTIAL IGNITION SOURCES, inductors and windings CONDUCTIVELY CONNECTED TO THE MAINS, and apparatus with open circuit voltages exceeding 4 kV (peak) a.c. or d.c. under normal operating conditions shall be contained in a FIRE ENCLOSURE ~~which shall~~ and comply with the flammability category in table 14 FV 1 or better according to ~~IEC 60707~~ UL 94 or UL 746C as specified.

~~Wood and WOOD-BASED MATERIAL with a thickness of at least 6 mm is considered to fulfill the FV 1 requirement of this subclause.~~

*Compliance is checked in accordance with ~~IEC 60707 or clause G.1 of annex G~~ UL 94 or UL 746C for the smallest thickness used.*

**Table 14 DU – Flammability categories for FIRE ENCLOSURES**

Table 14 revised June 23, 2000

<u>Enclosure material/application</u>	<u>Flammability category</u>
<u>Wood and metal</u>	<u>None</u>
<u>Polymeric:</u>	
<u>a) apparatus using high voltage components<sup>a</sup></u>	
<u>MAJOR ENCLOSURE PART</u>	<u>V-0</u>
<u>Other part</u>	<u>V-1, V-0</u>
<u>b) commercial audio STATIONARY APPARATUS and PERMANENTLY CONNECTED APPARATUS</u>	<u>5VA</u>
<u>c) other than apparatus itemized in a) and b) above<sup>a</sup></u>	<u>V-2, V-1, V-0</u>
<u>Hardboard back cover – apparatus using high voltage components</u>	<u>V-1, 746-5VS</u>
<sup>a</sup> <u>A MAJOR ENCLOSURE PART that is not fabricated at the apparatus manufacturing location shall be identified according to the requirements in UL 746D.</u>	

**20.2.2 DU** Internal FIRE ENCLOSURES shall not have openings for ventilation exceeding 1 mm in width ~~regardless of length~~ that permit accessibility to POTENTIAL IGNITION SOURCES and to inductors and windings CONDUCTIVELY CONNECTED TO THE MAINS and shall comply with the material requirements in table 14.

~~Openings for connecting wires shall be filled completely by the wires.~~

*Compliance is checked by inspection and measurement and using the jointed test finger.*

**20.2.3 DU** If the requirements of 20.2.1 and 20.2.2 are met by an internal FIRE ENCLOSURE ~~no requirements apply to the outer enclosure of the apparatus or to components or parts adjacent to the internal FIRE ENCLOSURE~~ shall have a rating of HB or better in accordance with UL 94. Insulation of internal wiring complying with 20.1.2 is considered to be an internal FIRE ENCLOSURE.

*Compliance is checked by inspection.*

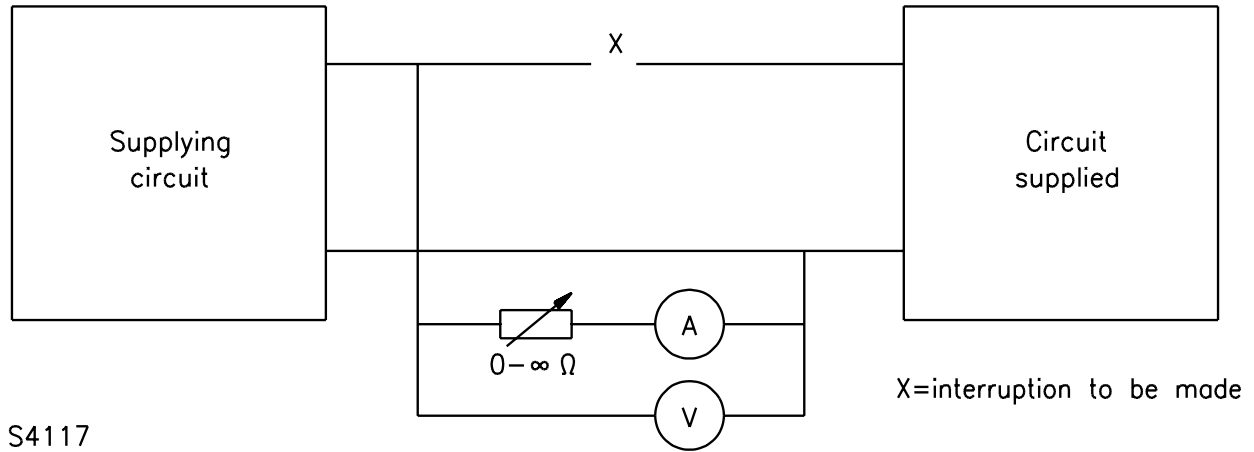

NOTE – See 4.3.

Figure 1 – Test circuit for fault conditions

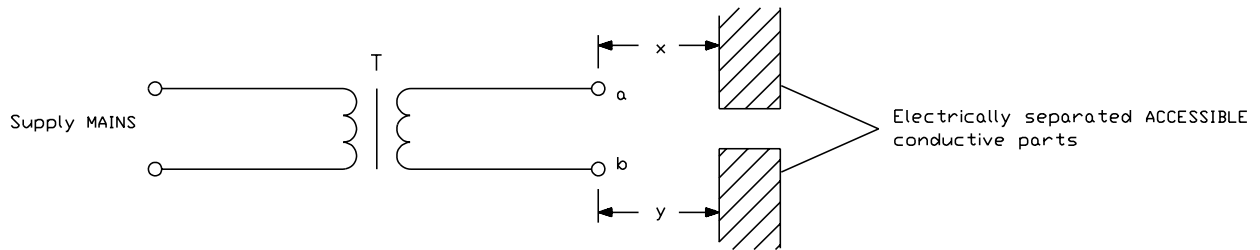

SM1064A

The diagram shows a SEPARATING TRANSFORMER T, where point a is HAZARDOUS LIVE relative to point b. If a and b are inside the apparatus, the sum of the distances x and y is taken into account for the purpose of checking compliance with 8.6.

NOTE – See 8.6.

Figure 2 – Example of an assessment of REINFORCED INSULATION

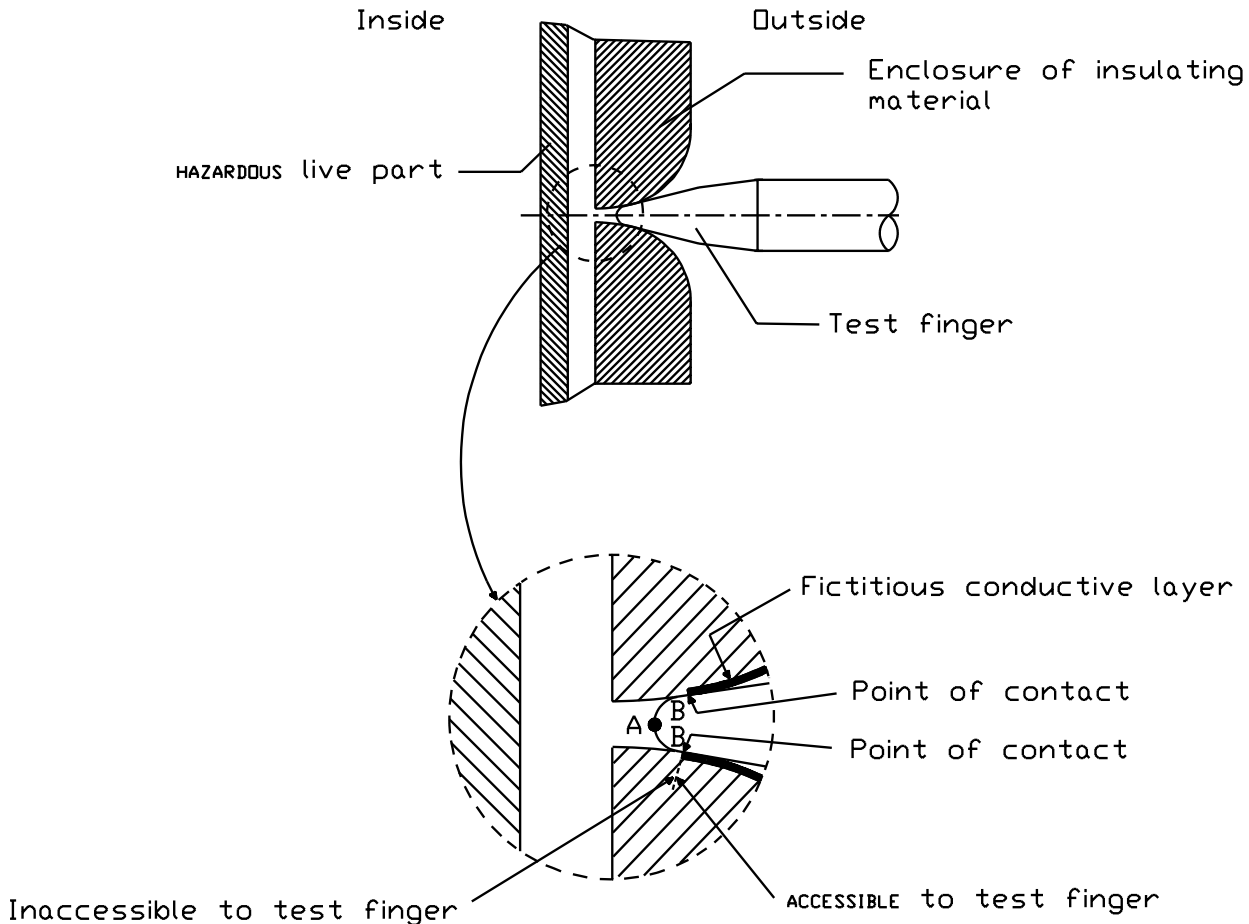

SM970C

- Point A is used for determining accessibility (see 9.1.1)
- Point B is used for measurements of CLEARANCES and CREEPAGE DISTANCES (see clause 13)

NOTE – See 9.1.1 and 13.1.1.

Figure 3 – Example of ACCESSIBLE parts

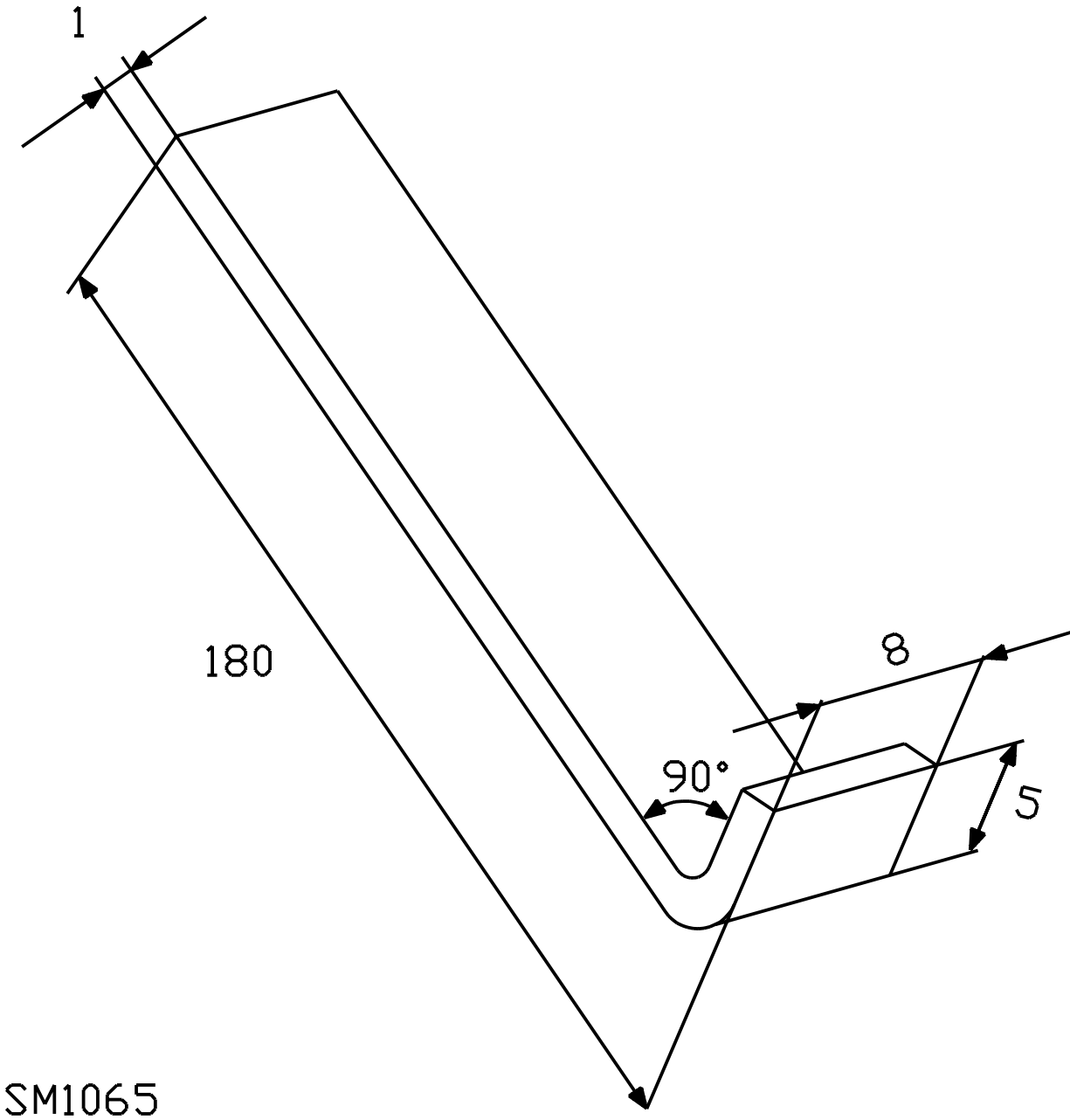

SM1065

*Dimensions in millimetres*

NOTE – See 9.1.7.

**Figure 4 – Test hook**



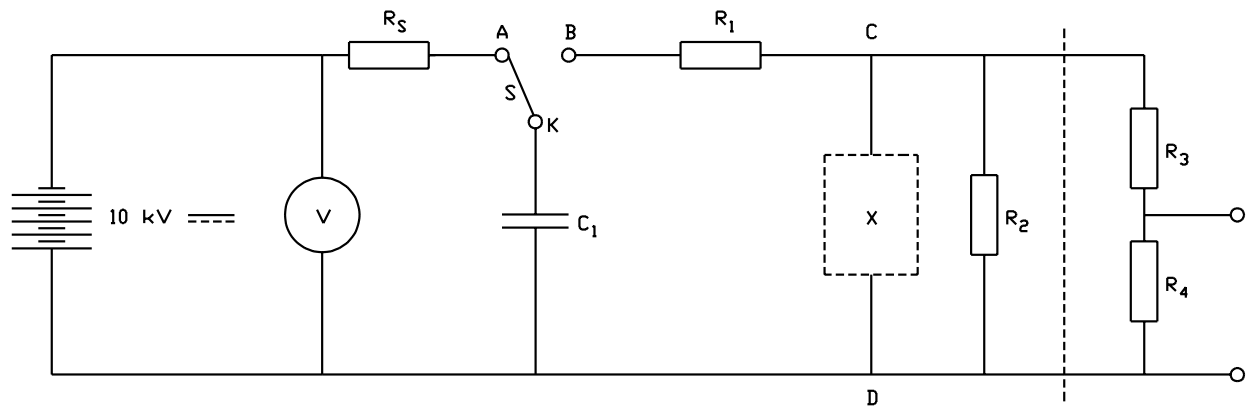

SM1038A

$C_1 = 1 \text{ nF}$   $R_1 = 1 \text{ k}\Omega$   $R_2 = 4 \text{ M}\Omega$   $R_3 = 100 \text{ M}\Omega$   $R_4 = 0.1 \text{ M}\Omega$   $R_S = 15 \text{ M}\Omega$

( $R_2$  is used only when the tests of 14.2 are performed on a component comprising a capacitor only.)

The switch S is a critical part of the circuit. It must be so designed that as little as possible of the available energy is dissipated in arcing or inadequate insulation. An example of such a switch is given in figure 5B.

The component X under test is connected to the terminals C and D. Optionally the voltage divider  $R_3$ ,  $R_4$  may be provided so that an oscilloscope connected across  $R_4$  permits the observation of the voltage waveform across the component under test. This voltage divider is compensated so that the observed waveform corresponds with that across the component under test.

NOTE – See 10.1 and 14.1.

**Figure 5A – Surge test – Test circuit**

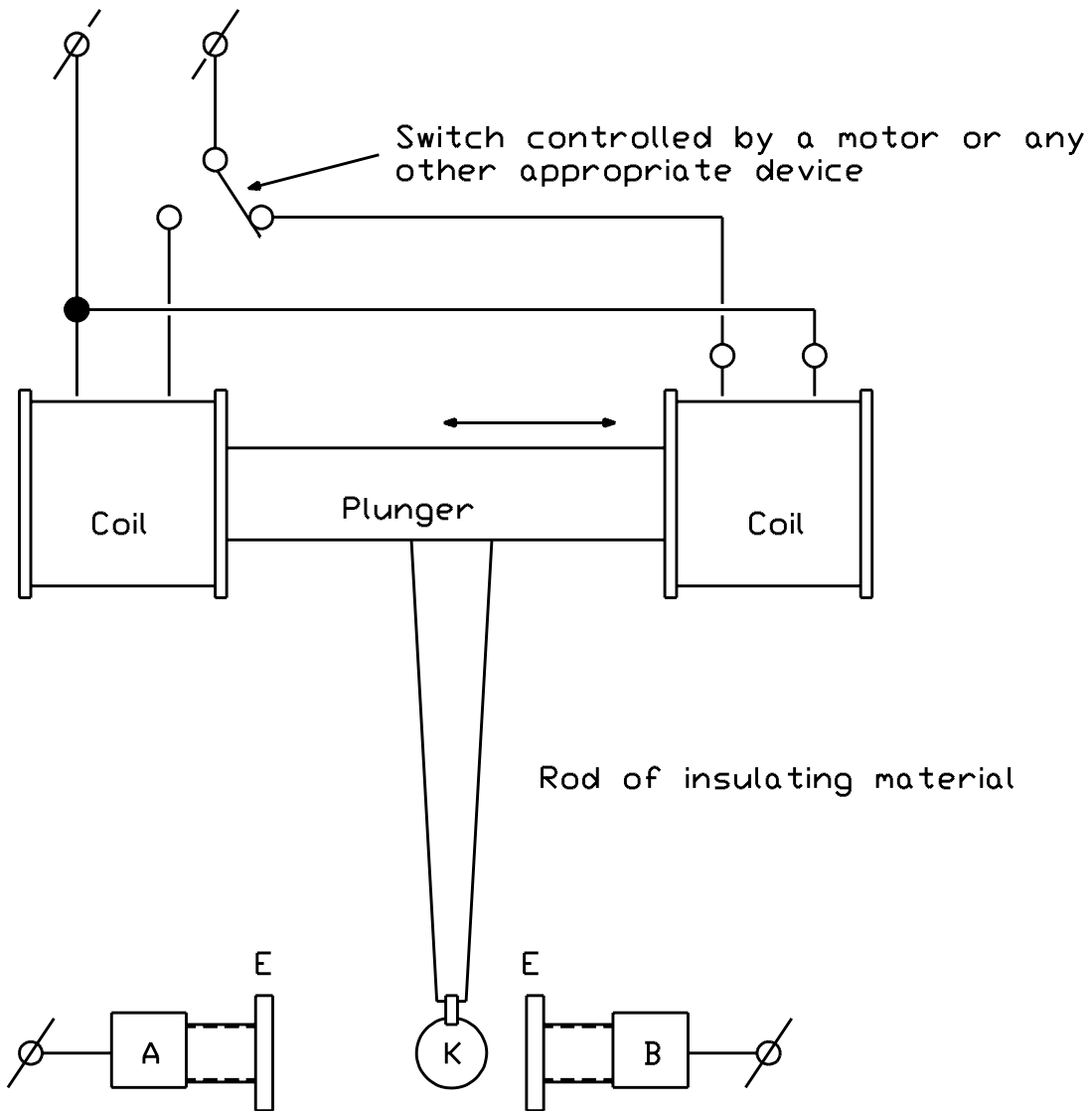

SM1050A

The switch (S in figure 5A) comprises the following parts:

- the brass pillars A and B support circular electrodes E spaced at a distance of 15 mm;
- K is a brass sphere of 7 mm diameter and is supported on a rigid rod of insulating material approximately 150 mm long.

A, B and K are connected as shown in figure 5A, K by means of a flexible wire

Care shall be taken to avoid bouncing of sphere K.

**Figure 5B – Surge test – Example of a switch to be used in the test circuit**

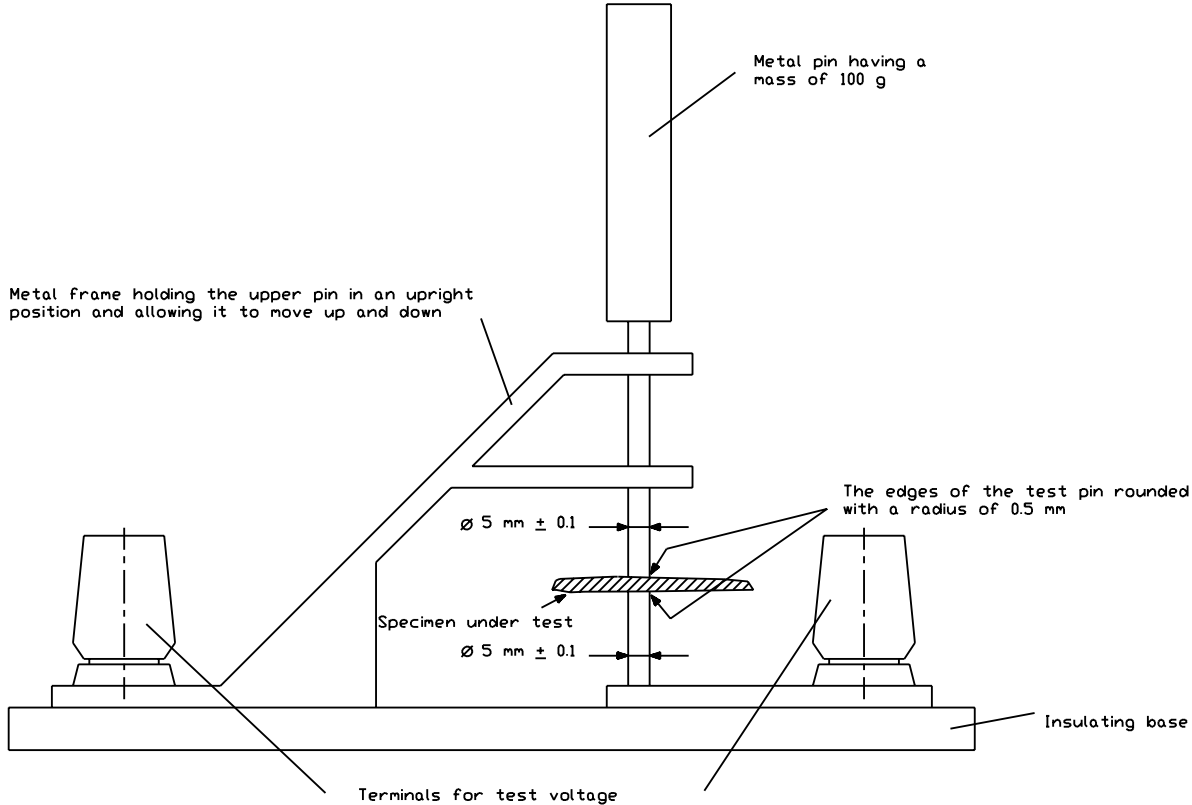

SM1053

NOTE – See 10.3.2.

Figure 6 – Dielectric strength test instrument

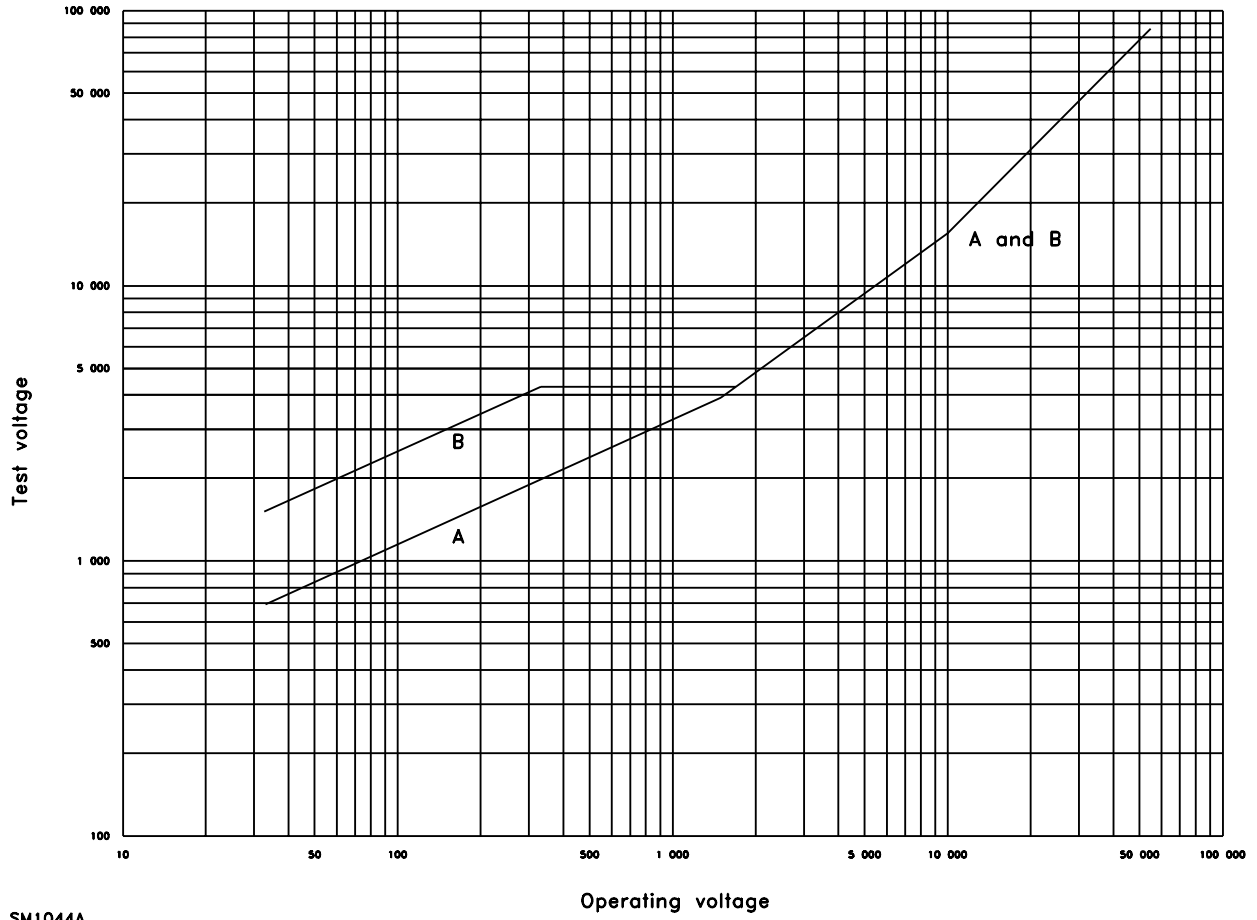

Dimensions in millimeters

NOTE – See 10.3.2 + table 3.

Figure 7 – Test voltages

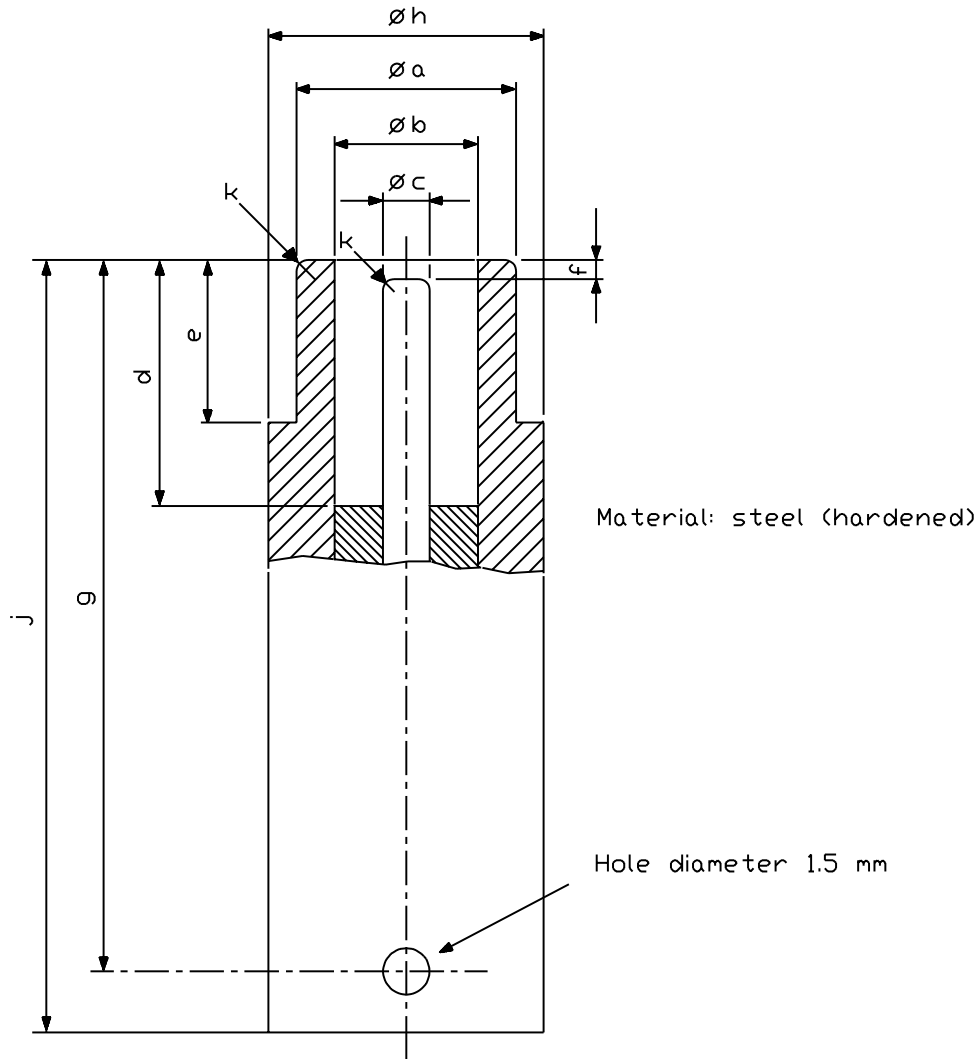

SM1056

Dimensions in millimeters

a	b	c	d	e	f	g	h	j	k
0	min.	0	min.	min.					min.
9576 -1	8.05	2438 -1	9.1	7112	0.8 ± 0.4	40 ± 0.4	12 ± 0.4	43 ± 0.4	0.3 radii

The mating section of the test plug is in accordance with IEC 60169-2 [3], figure 7.

NOTE – See 12.5.

**Figure 8 – Test plug for mechanical tests on antenna coaxial sockets**

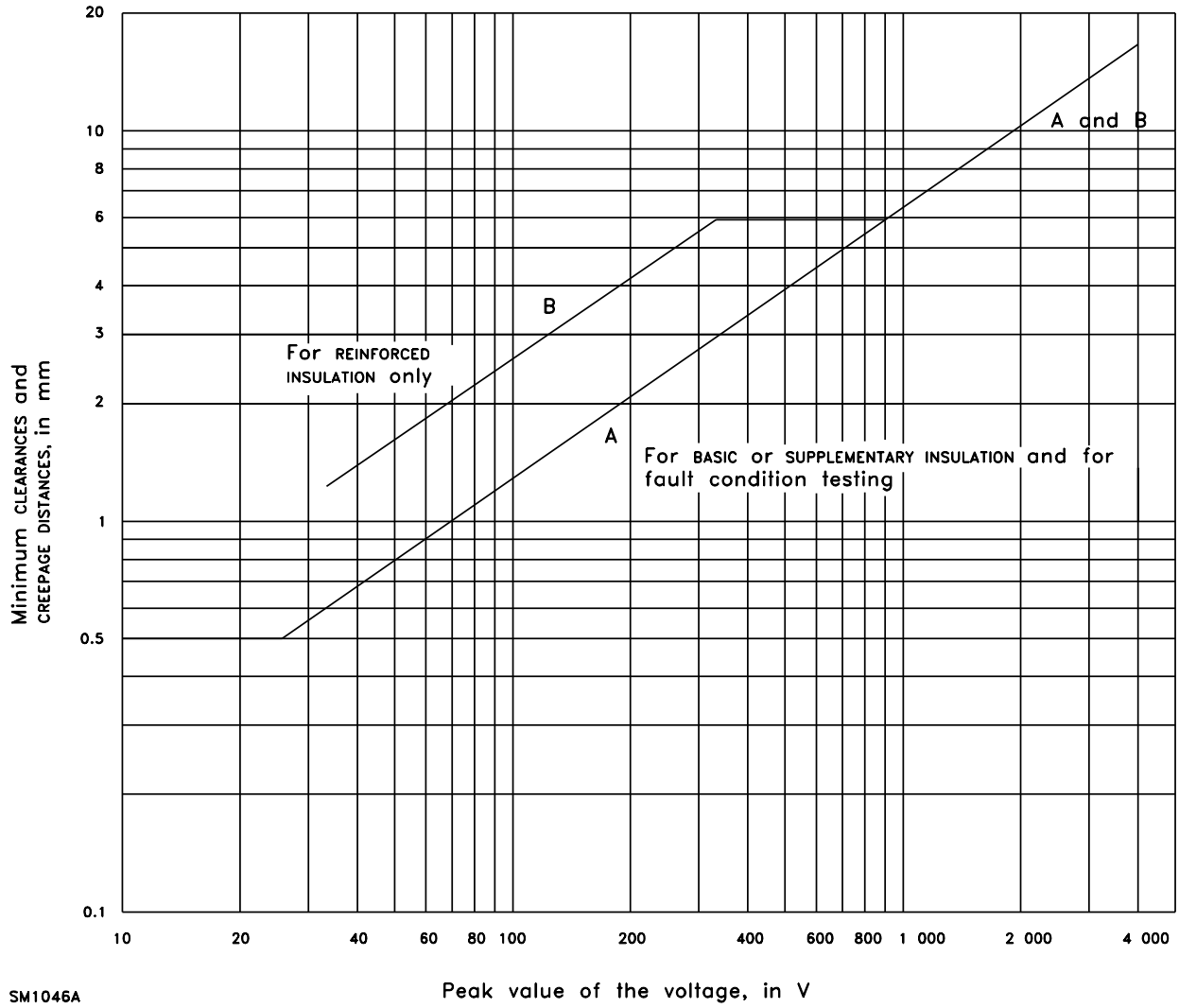

SM1046A

NOTE – Refer to Notes 1 – 8 on following page.

Figure 9 DU – CLEARANCES and CREEPAGE DISTANCES

Figure 9 DU continued

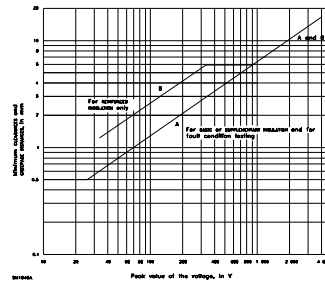

NOTE 1 – The given values are applicable to BASIC, SUPPLEMENTARY and REINFORCED INSULATION.

NOTE 2 – For BASIC, SUPPLEMENTARY and REINFORCED INSULATION, all parts of the circuit CONDUCTIVELY CONNECTED TO THE MAINS are assumed to be at not less than the nominal MAINS voltage with respect to earth.

For parts CONDUCTIVELY CONNECTED TO THE MAINS with voltages in the range of 105 – 130 V (r.m.s.), the values are equal to those related to 177 V peak.

For parts CONDUCTIVELY CONNECTED TO THE MAINS with voltages in the range of 220 – 250 V (r.m.s.), the values are equal to those related to 354 V peak.

NOTE 3 – A voltage across the BASIC INSULATION is determined by short-circuiting the SUPPLEMENTARY INSULATION and vice versa.

NOTE 4 – For voltages exceeding 4000 V (peak) a.c. or d.c., the voltage test according to 10.3 is used to determine whether a CLEARANCE and CREEPAGE DISTANCE shall be short-circuited during the tests under fault condition.

NOTE 5 – The graphs are defined by the following:

Curve A:

34 V corresponds to 0.6 mm

177 V corresponds to 1.5 mm

354 V corresponds to 3.0 mm

Curve B:

34 V corresponds to 1.2 mm

177 V corresponds to 3.0 mm

354 V corresponds to 6.0 mm

NOTE 6 – If enamel forms the insulation of a wire and withstands the voltage test prescribed for grade 2 or better of IEC 60317, it is considered to contribute 1 mm to the CLEARANCES and CREEPAGE DISTANCES, with a minimum as specified in 13.1.1.

NOTE 7 – The specified CLEARANCES and CREEPAGE DISTANCES are the minimum actual separations taking into account tolerances in assemblies and piece-parts.

NOTE 8 – See clause 13.

**Figure 9 DU – CLEARANCES and CREEPAGE DISTANCES**

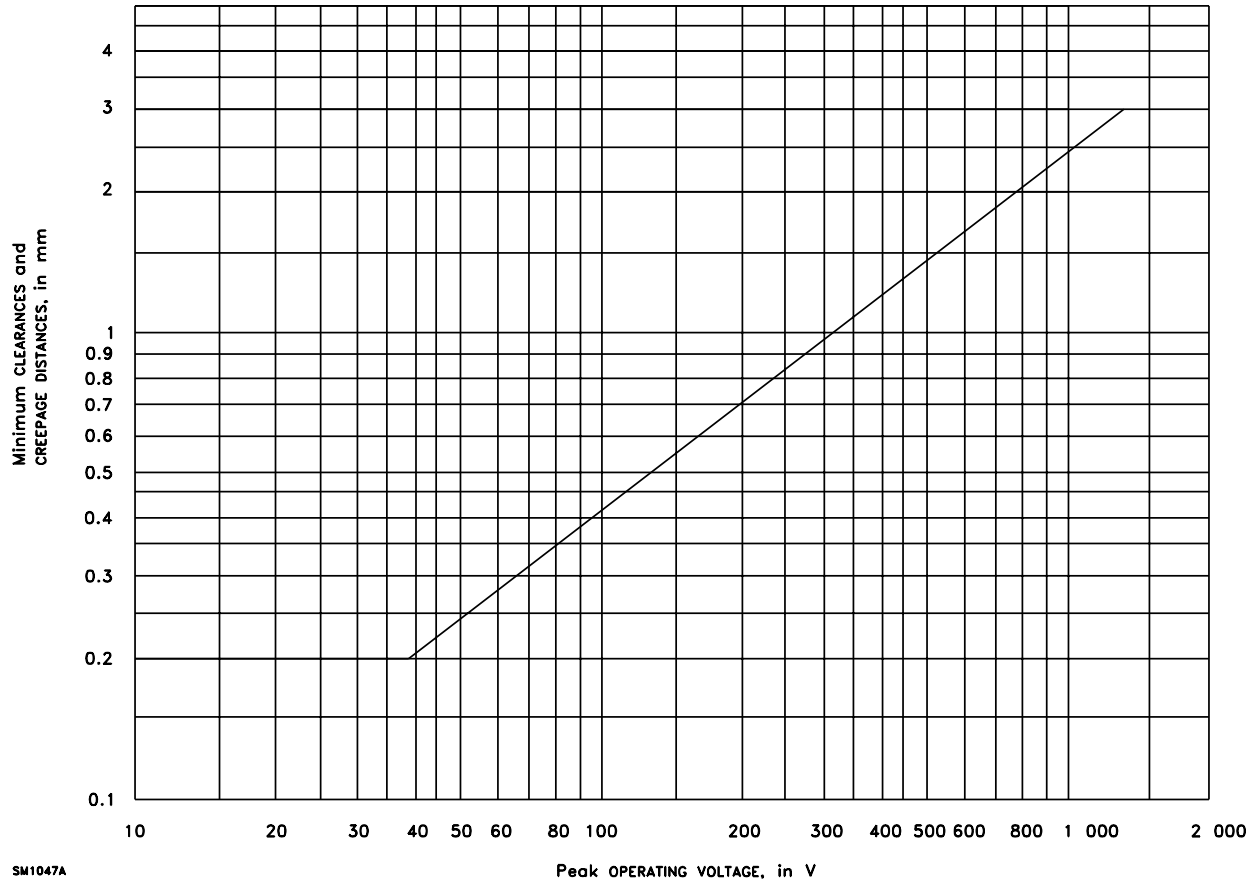

The curve is defined by the formula:

$$\log d = 0.78 \log (V/300)$$

with a minimum of 0.2 mm

d = distance

V = peak voltage (V)

NOTE – See 13.2.

**Figure 10 – Minimum CLEARANCES and CREEPAGE DISTANCES on PRINTED BOARDS**



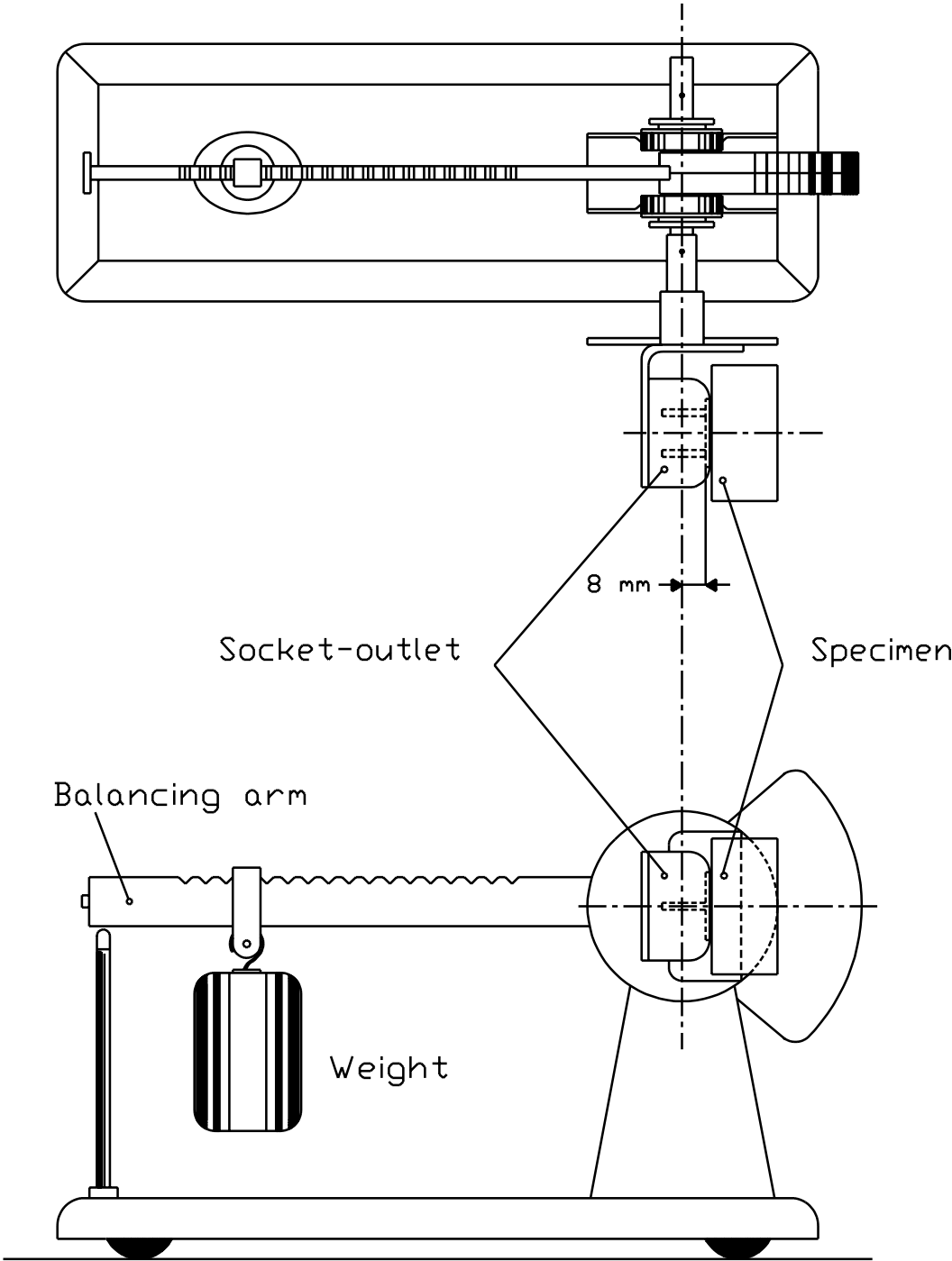

SM1055B

NOTE – See 15.4.1.

Figure 11 – Test apparatus for devices forming a part of the MAINS plug

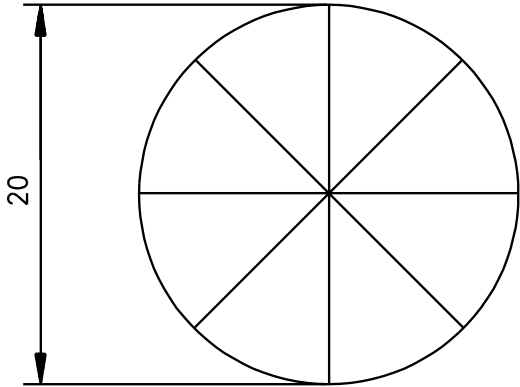

SM1040

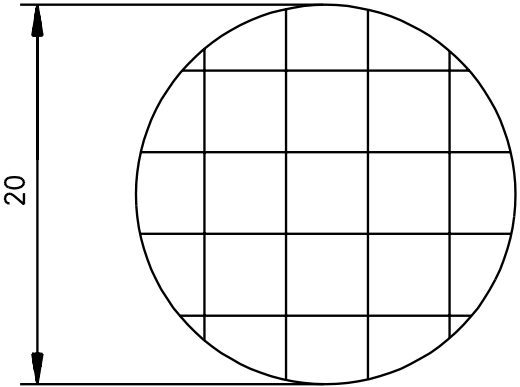

*Dimensions in millimeters*

NOTE – See 18.2.2.

**Figure 12 – Scratch patterns for implosion test**



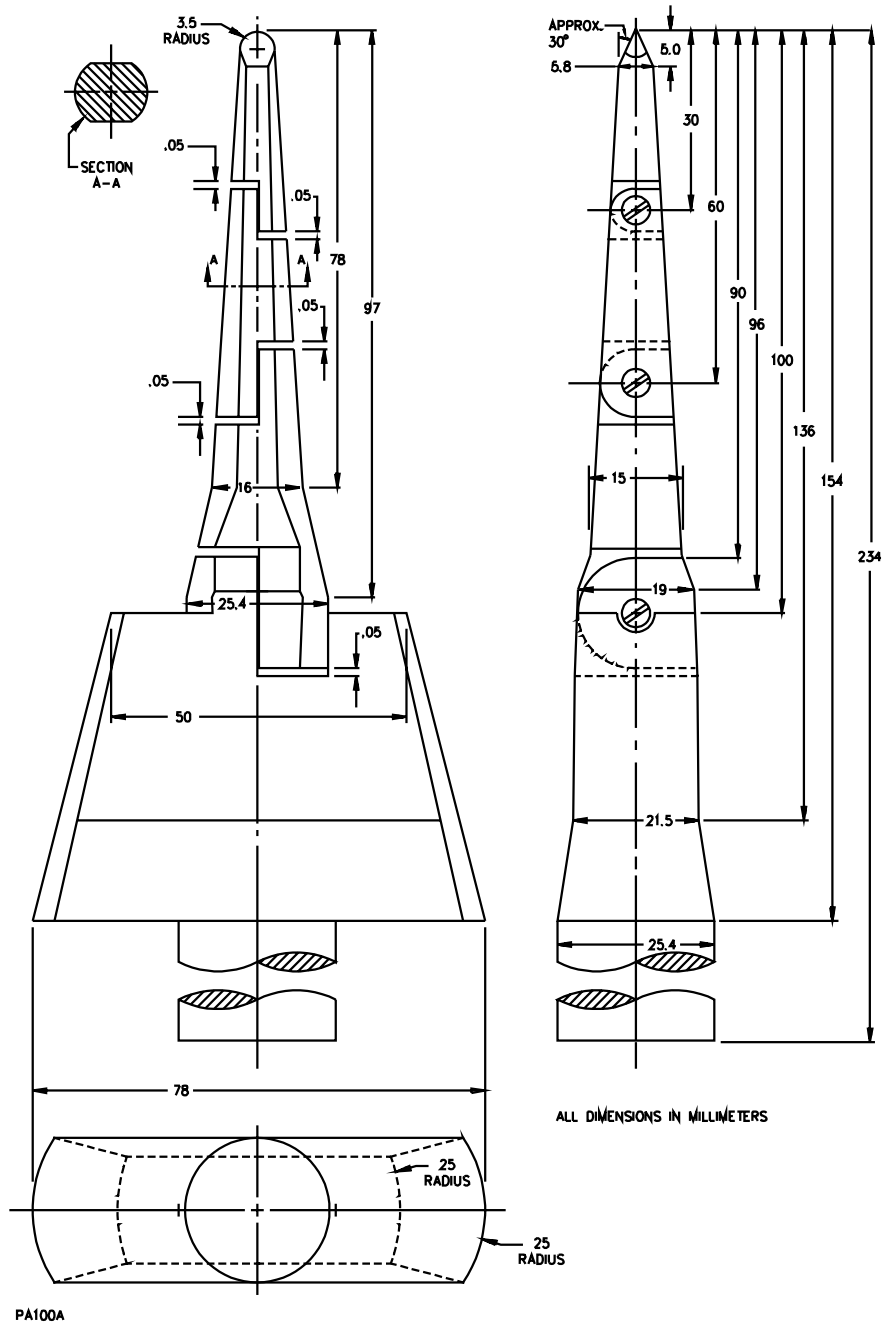

NOTE – See 9.1.1.

Figure 14 DU – Articulated finger probe

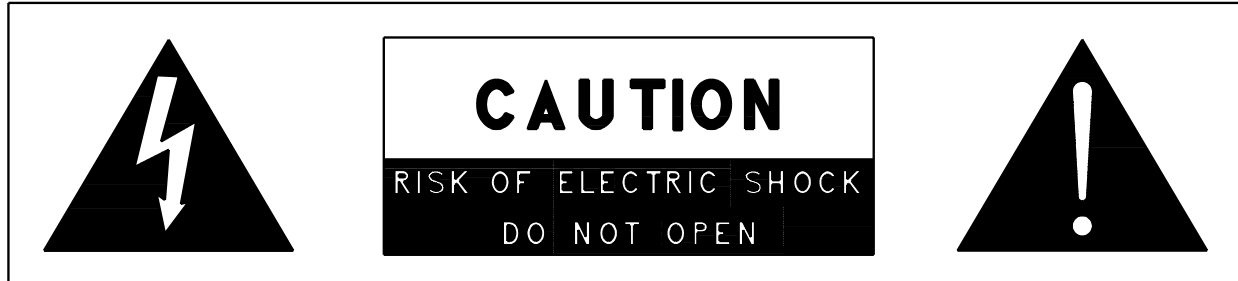

SB1977A

NOTE – See 5.1.

Figure 15 DU – Shock hazard marking and associated graphical symbols

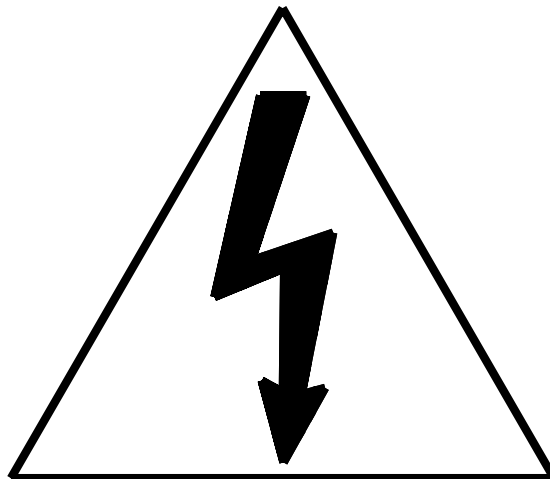

**SA1965**

NOTE – See 5.1.

Figure 16 DU – Shock hazard graphical symbol



S3125A

NOTE – See 5.4.

**Figure 17 DU – Portable cart warning**

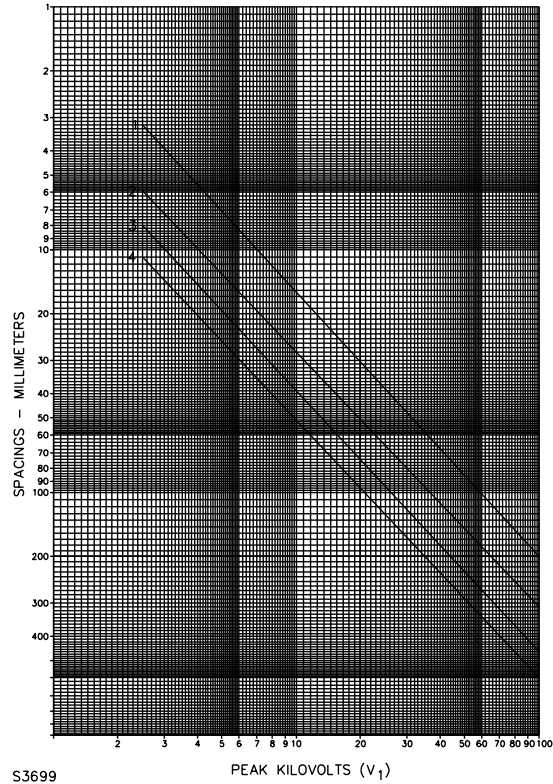

$V_1$  – Measured as described in Sub-clause 14.4.1.

Curve 1 – Clearance spacings.

Curve 2 – Creepage spacings – insulating materials having an arc-tracking Performance Level Category (PLC) of 0, 1, 2, 3, or 4.

Curve 3 – Creepage spacings – insulating materials having an arc-tracking PLC of 5.

Curve 4 – Creepage spacings – insulating materials having an arc-tracking PLC of 6 or 7.

NOTE 1 – Use voltage value of  $2V + 1000$  for through-air spacings referred to in Sub-clause 14.4.1 and the peak measured voltage for spacings referred to in Sub-clause 14.4.1.

NOTE 2 – The arc-tracking characteristics of insulating materials are to be determined by the tests described in the Standard Test for High-Voltage, Low-Current, Arc Resistance of Solid Electrical Insulating Material, ASTM D495.

NOTE 3 – Performance Level Category (PLC) refers to an integer that defines a range of test values for a given electrical/mechanical property test as described in the Standard for Polymeric Materials – Use in Electrical Equipment Evaluations, UL 746C.

NOTE 4 – See 14.4.1

**Figure 18 DU – High voltage spacings**

Figure 18 revised June 23, 2000

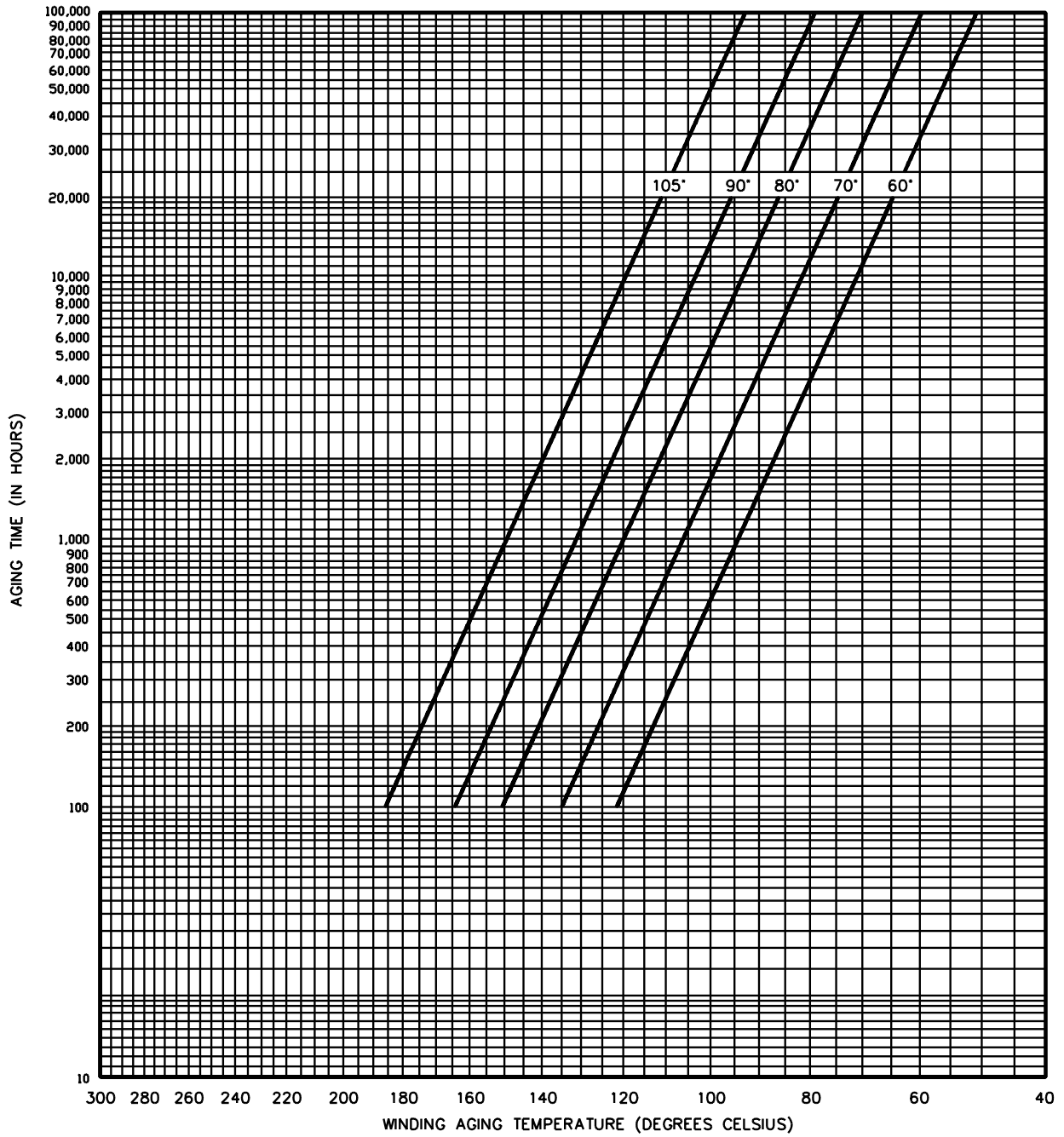

S3295B

NOTE - See 14.4.3

Figure 19 DU - Class 105 insulation aging temperatures



**Annex A**  
(normative)

**Additional requirements for apparatus ~~with protection against splashing water~~ intended for OUTDOOR LOCATION USE, WET LOCATION use, or permanent OUTDOOR LOCATION use. An apparatus is determined to be intended for OUTDOOR LOCATION use or for use in a WET LOCATION when it has any one of the following attributes:**

The requirements of this standard supplemented or replaced by those contained in this annex, apply to apparatus ~~provided with protection against splashing water~~ intended for OUTDOOR LOCATION USE, WET LOCATION use, or permanent OUTDOOR LOCATION use. An apparatus is determined to be intended for OUTDOOR LOCATION use or for use in a WET LOCATION when it has any one of the following attributes:

- a) It is provided with a means (handles, wheels, casters, etc.) making it transportable.
- b) Its mass is less than 35 kg.
- c) It is capable of being operated from a battery.
- d) The literature provided with the apparatus indicates or implies use in an OUTDOOR LOCATION OR a WET LOCATION.

An apparatus as described in (a), (b) or (c) above that is marked as specified in 5.4.1(a) is not intended for use in an OUTDOOR LOCATION OR WET LOCATION.

An apparatus is determined to be for permanent OUTDOOR LOCATION use when its use entails that it be permanently installed outdoors.

**A.2.8.14 DU**

OUTDOOR LOCATION

an unprotected location exposed to weather

**A.2.8.15 DU**

WET LOCATION

in direct connect with earth, and locations subject to saturation with water

**A.5—DU Marking and instructions<sup>1)</sup>**

*Add the following item after 5.1 i):*

**A.5.1—DU j) Protection against splashing water**

~~Apparatus provided with protection against splashing water shall be marked at least with the designation IPX4 in accordance with IEC 60529.~~

*Compliance is checked by inspection.*

**A.5.4.1—DU a)** Subclause 5.4.1 a) does not apply.

**A.9.1.1 DU General**

The following supplements 9.1.1:

After being subjected to the conditions described in A.11.1.1, the touch current of an apparatus that is intended for use in an OUTDOOR LOCATION or WET LOCATION shall not be more than 0.5 MIU when the open-circuit potential between any ACCESSIBLE part and earth or any other ACCESSIBLE part is more than 21.2 V peak.

#### **A.10—DU Insulation requirements**

*Modify 10.2 as follows:*

#### **A.10.2—DU Splash and humidity treatment**

##### **A.10.2.1—DU Splash treatment**

The enclosure shall provide adequate protection against splashing water.

*Compliance is checked by the treatment specified below, which is made on the apparatus fitted with external flexible cords in accordance with the requirements of clause 16:*

*The apparatus is subjected to the test described in IEC 60529, subclause 14.2.4, item a):*

*Immediately after this treatment, the apparatus shall comply with the tests of 10.3 and inspection shall show that water, which may have entered the apparatus, does not cause any damage in the sense of this standard; in particular, there shall be no trace of water on insulations for which CREEPAGE DISTANCES are specified.*

##### **A.10.2.2—DU Humidity treatment**

Subclause 10.2 applies, *except that the duration of the test is seven days (168 h).*

A.11.1.1 DU The apparatus is to be positioned, but not operating, as in actual service and subjected for 1 hour to a water spray supplied by the rain test apparatus specified in UL 1571.

A.20.2.1 DU Enclosures for apparatus intended for permanent OUTDOOR LOCATION shall comply with the requirements for Type 3 enclosures in UL 50.

<sup>1)</sup> The clause numbering of this annex refers to the clauses of this standard.

**Annex B**  
(normative)  
**Apparatus to be connected to the TELECOMMUNICATION NETWORKS**

The requirements of this standard supplemented by those contained in this annex, apply to apparatus within the scope of this standard intended to be connected to TELECOMMUNICATION NETWORKS.

NOTE 1 – Attention is drawn to the fact that the telecommunication authorities may impose additional requirements on apparatus to be connected to TELECOMMUNICATION NETWORKS. Those requirements generally concern the protection of the networks as well as the USERS of the apparatus.

NOTE 2 – In Australia, the telecommunication network authorities require compliance to a national variation of IEC 60950.

**B.1.1.3 DU Apparatus intended to be connected directly or indirectly to a TELECOMMUNICATION NETWORK and containing an earphone which is held against the ear shall be subjected to Acoustic Tests per 6.4.3 of UL 1950, Third Edition.**

**Apparatus intended for connection to a TELECOMMUNICATION NETWORK that uses outside cable subject to overvoltage from power line failures shall comply with requirements for protection against overvoltage from power line crosses per 6.6 of UL 1950, Third Edition.**

## **B.2 Definitions <sup>1)</sup>**

*Add the following two definitions to 2.5:*

### **B.2.5.5**

TELECOMMUNICATION SIGNAL

A steady state, varying amplitude or intermittent voltage or current intended for use on a TELECOMMUNICATION NETWORK.

NOTE – The limiting values are specified in IEC 60950, Subclause 6.2.1.1.

### **B.2.5.6**

TELECOMMUNICATION NETWORK VOLTAGE (TNV) CIRCUIT

A circuit that, under normal operating conditions, carries TELECOMMUNICATION SIGNALS.

## **B.5 DU Marking and instructions**

*Add the following items after 5.4.1 d):*

e) Where the separation of TELECOMMUNICATION NETWORK VOLTAGE (TNV) CIRCUITS from other circuits relies on protective earthing of the apparatus, according to B.8.1 b), the apparatus installation instructions and other relevant literature shall state that the integrity of protective earthing shall be ensured.

NOTE 1 – In Norway, if separation between the MAINS and a communication system/network, other than public TELECOMMUNICATION NETWORKS, relies upon connection to the safety earth, the apparatus shall have a marking stating that it must be connected to an earthed MAINS socket-outlet.

For requirements for apparatus to be connected to a public TELECOMMUNICATION NETWORK, see B.8.1.

NOTE 2 – In Sweden, if – for apparatus to be connected to the MAINS by means of a plug – the separation between the MAINS and a TELECOMMUNICATION NETWORK relies upon connection to protective earth, the apparatus shall have a marking stating that it must be connected to an earthed MAINS socket outlet.

f) Apparatus intended to be connected to the TELECOMMUNICATION NETWORK shall be provided with the appropriate markings and instructions described in annex NAA (6.1) of UL 1950, Third Edition.

## **B.8 Constructional requirements with regard to protection against electric shock**

### **B.8.1 Add the following text to 8.1:**

TELECOMMUNICATION NETWORK VOLTAGE (TNV) CIRCUITS shall be separated from circuits CONDUCTIVELY CONNECTED TO THE MAINS and from HAZARDOUS LIVE parts or circuits as determined in 9.1.1 by one or both of the following methods:

- a) by DOUBLE OR REINFORCED INSULATION as detailed in 8.6;
- b) by BASIC INSULATION together with PROTECTIVE SCREENING connected to the PROTECTIVE EARTH TERMINAL, as detailed in 8.5.

NOTE 1 – In Denmark, method b) is permitted only for PERMANENTLY CONNECTED APPARATUS.

NOTE 2 – In Norway, method b) is not permitted. Insulation between parts CONDUCTIVELY CONNECTED TO THE MAINS and parts connected to a public TELECOMMUNICATION NETWORK shall comply with the requirements for DOUBLE OR REINFORCED INSULATION.

For the purpose of 8.5 and 8.6, the voltage is the sum of the MAINS voltage and the TNV voltage which is assumed to be 135 V (peak) a.c.

NOTE 3 – In the USA and Canada, the TNV voltage is assumed to be 170 V (peak).

### **B.8.2 Add the following text to 8.2:**

TNV CIRCUITS shall be separated from circuits other than mentioned in B.8.1 and from ACCESSIBLE conductive parts by BASIC INSULATION meeting the insulation requirements for CLEARANCES and CREEPAGE DISTANCES as specified in clause 13, for a voltage which is the sum of the voltage in the circuit and the TNV voltage which is assumed to be 135 V (peak) a.c.

NOTE – In the USA and Canada, the TNV voltage is assumed to be 170 V (peak).

## **B.9 Electric shock hazard under normal operating conditions**

### **B.9.1.1 DU Add the following text to 9.1.1:**

Contacts of TERMINALS for TNV CIRCUITS which cannot be touched by the test probe figure B.1, are an additional exemption from the requirement for inaccessible TERMINAL contacts.

Apparatus containing input TELECOMMUNICATION NETWORK leads over which ringing voltages are applied to the equipment shall be subjected to Leakage Current due to Ringing Voltage tests per 6.3.4.3 of UL 1950, Third Edition.

**B.9.1.4** *Add the following text to 9.1.4:*

The straight test probe according to IEC 61032, test probe D, is not applied to TNV CIRCUIT TERMINALS.

**B.10 Insulation requirements****B.10.1** *Add the following text to 10.1:*

The insulation between TNV CIRCUIT TERMINALS and:

- TERMINALS for the connection of antenna,
- any other TERMINAL in case of apparatus which may be interconnected to other apparatus with antenna TERMINALS,

is also subjected to the specified 50 discharges.

**B.10.3** *Add the following text to 10.3:*

The test voltages between TNV CIRCUITS and other parts shall be determined according to the OPERATING VOLTAGES mentioned in B.8.1.

Surge suppressors shall be disconnected during the dielectric strength test.

**B.14 Components**

*Add the following new subclause:*

**B.14.12 Surge suppressors**

If surge suppressors are connected between TNV CIRCUITS and other parts of the apparatus, the surge suppressors shall have a nominal d.c. spark-over voltage of at least 1.8 times the rated MAINS voltage of the apparatus.

NOTE 1 – In Denmark the use of surge suppressors between the TELECOMMUNICATION NETWORK and conductive ACCESSIBLE parts or TERMINALS which are considered to be ACCESSIBLE, is allowed only for PERMANENTLY CONNECTED APPARATUS.

NOTE 2 – In Sweden and Norway, for CLASS I apparatus intended to be connected to the MAINS by means of a plug, surge suppressors may only be connected between TNV circuits and ACCESSIBLE parts if the apparatus has a marking stating that it must be connected to an earthed MAINS socket outlet.

<sup>1)</sup> The clause numbering of this annex refers to the clauses of this standard.

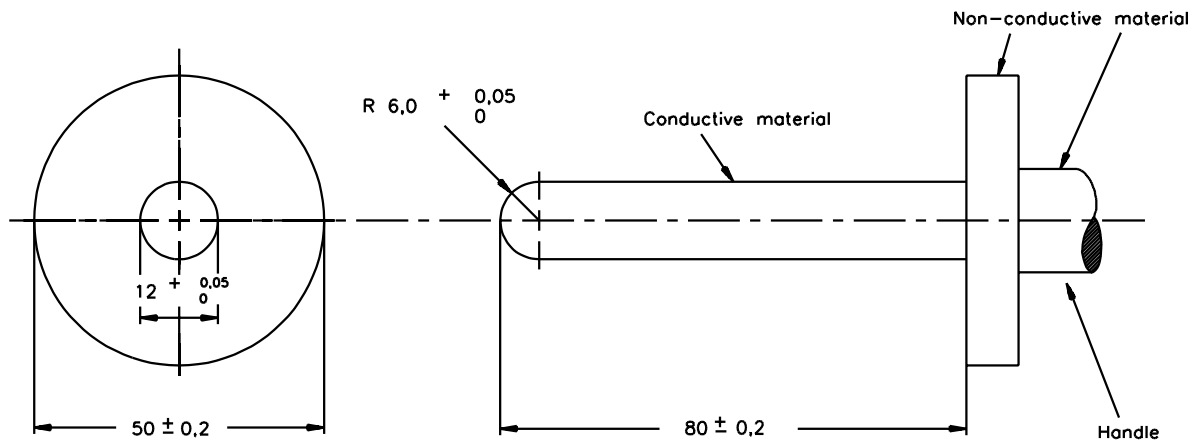

SM430

*Dimensions in millimetres*

NOTE – See B.9.1.1.

**Figure B.1 – Test probe**

**Annex C**  
(normative)  
**Band-pass filter for wide-band noise measurement**  
(Extract of IEC 60268-1)

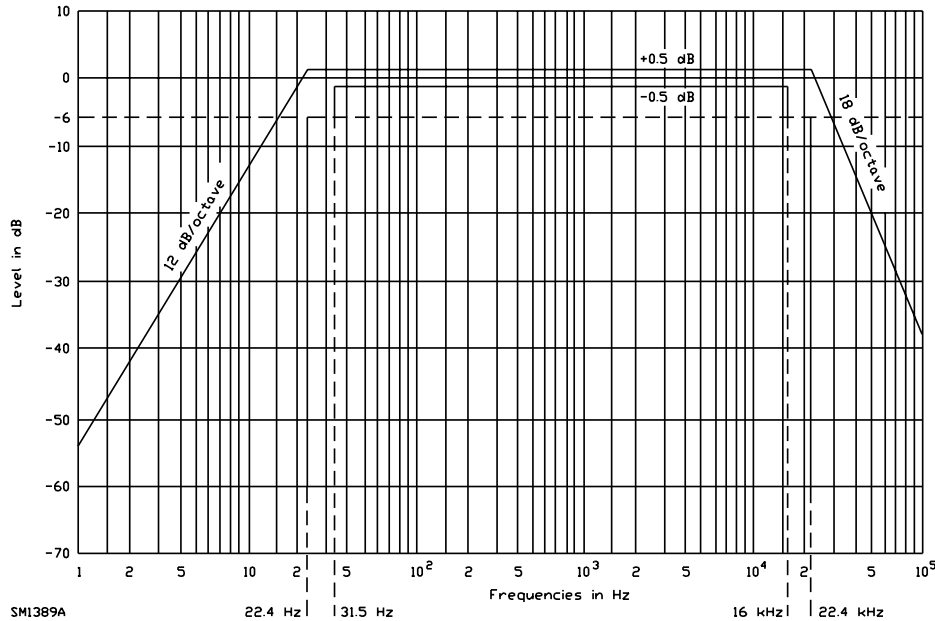

**Figure C.1 – Band-pass filter for wide-band noise measurement  
(amplitude/frequency response limits, see below)**

*Wide-band measurement (see IEC 60268-1, subclause 6.1)*

The filter shall be a band-pass filter having a frequency response within the limits shown in figure C.1.

A band-pass filter which has a substantially constant transmission factor between 22.4 Hz and 22.4 kHz, decreasing outside this frequency band at the rates specified for octave-band filters having mid-band frequencies of 31.5 Hz and 16,000 Hz specified in IEC 61260, has a response falling within the limits of this specification.

NOTE 1 – Care should be taken when there may be strong signals just above or below the band-limits since in this case the results will depend, to some degree, on the individual frequency response of the filter actually used.

NOTE 2 – See 4.1.6.

No Text on This Page



**Annex D**  
(normative)  
**Measuring network for TOUCH CURRENTS**

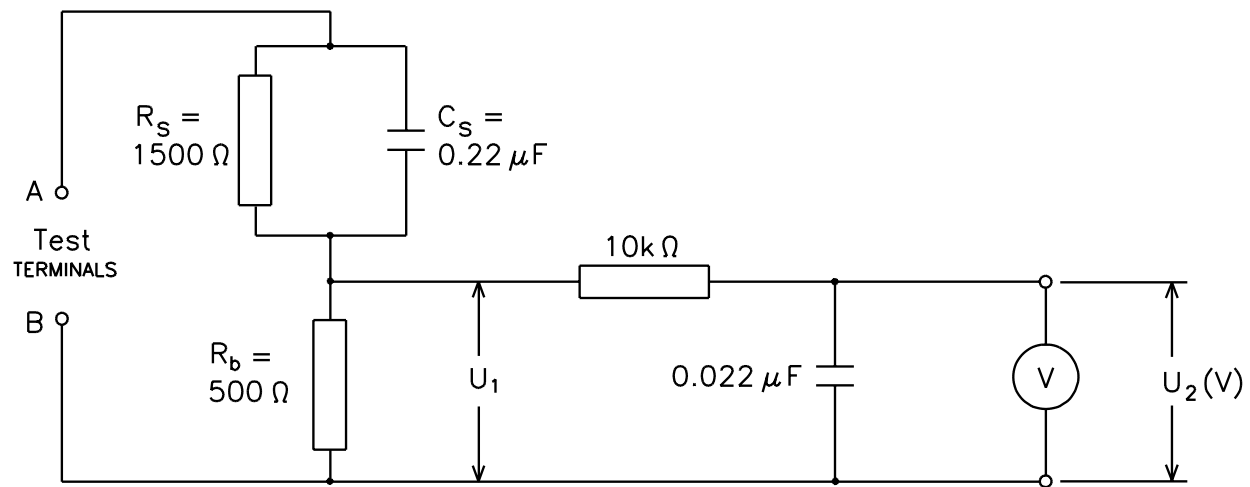

S3991A

**Figure D.1 – Measuring network for TOUCH CURRENTS according to IEC 60990 ANSI C101**

*Resistance values in ohms ( $\Omega$ )*

V: Voltmeter or oscilloscope

(r.m.s. or peak-reading)

Input resistance:  $\geq 1 \text{ M}\Omega$

Input capacitance:  $\leq 200 \text{ pF}$

Frequency range: 15 Hz to 1 Mhz and d.c. respectively

NOTE – Appropriate measures should be taken to obtain the correct value in case of non-sinusoidal waveforms.

The measuring instrument is calibrated by comparing the frequency factor of  $U_2$  with the solid line in figure F.2 of IEC 60990 at various frequencies. A calibration curve is constructed showing the deviation of  $U_2$  from the ideal curve as a function of frequency: in accordance with ANSI C101.

TOUCH CURRENT =  $U_2/500$  (peak value)

$MIU = U_2 / 500$  (r.m.s value)

NOTE – See 9.1.1.

No Text on This Page

**Annex E**  
(normative)  
**Measurement of CLEARANCES and CREEPAGE DISTANCES**

The methods of measuring and CLEARANCES and CREEPAGE DISTANCES which are specified in figures E.1 to E.10 are used in interpreting the requirements of this standard.

The minimum value of distance X is 0.25 mm for 13.3 and 1.0 mm for 13.2.

However, if the requirement for the CLEARANCE associated with the concerned CREEPAGE DISTANCE is less than 3.0 mm, the value X is one-third of the specified CLEARANCE, but not less than 0.2 mm.

..... CREEPAGE DISTANCE      \_\_\_\_\_ CLEARANCE

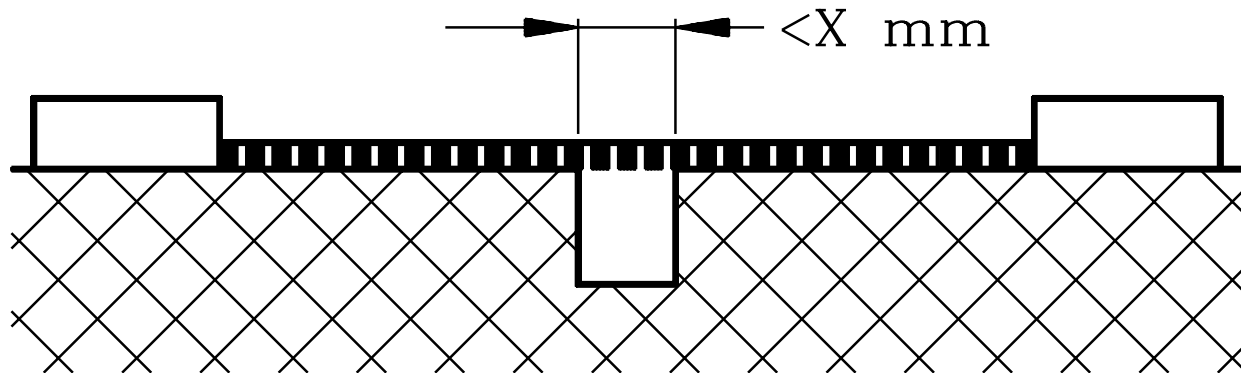

S3409A

Condition: Path under consideration includes a parallel or converging-sided groove of any depth with width less than X mm.

Rule: CLEARANCE and CREEPAGE DISTANCE are measured directly across the groove.

**Figure E.1 – Narrow groove**

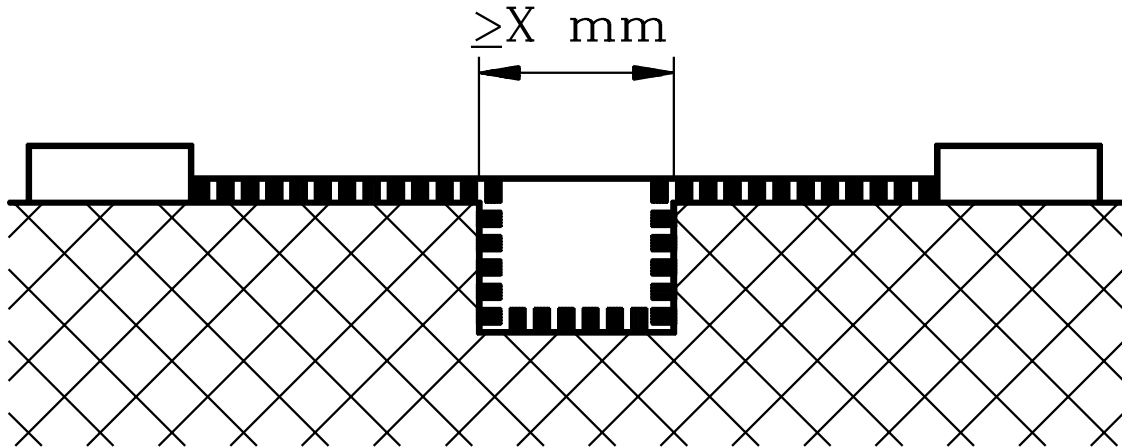

S3410A

Condition: Path under consideration includes a parallel-sided groove of any depth, and equal to or more than X mm wide.

Rule: CLEARANCE is the "line of sight" distance, CREEPAGE DISTANCE path follows the contour of the groove.

Figure E.2 – Wide groove

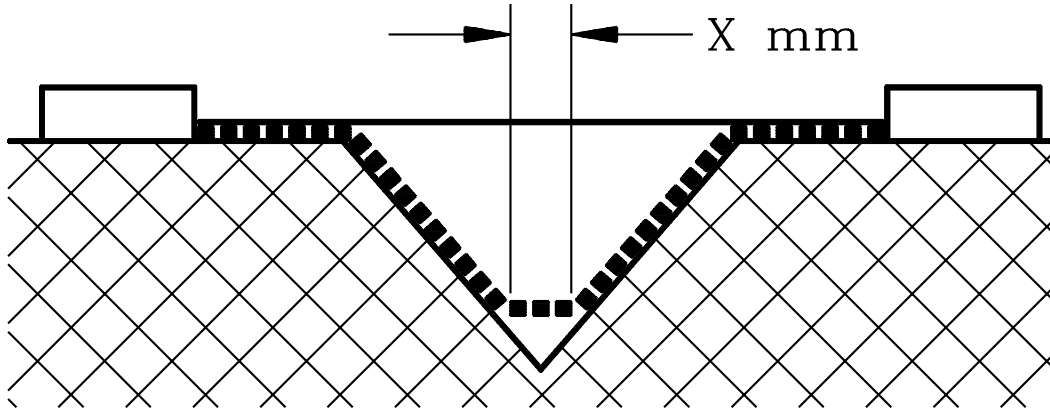

S3411A

Condition: Path under consideration includes a V-shaped groove with internal angle of less than  $80^\circ$  and a width greater than X mm

Rule: CLEARANCE is the "line of sight" distance. CREEPAGE DISTANCE path follows the contour of the groove but "short circuits" the bottom of the groove by 1 mm (13.2) respectively 0.25mm (13.3).

Figure E.3 – V-shaped groove

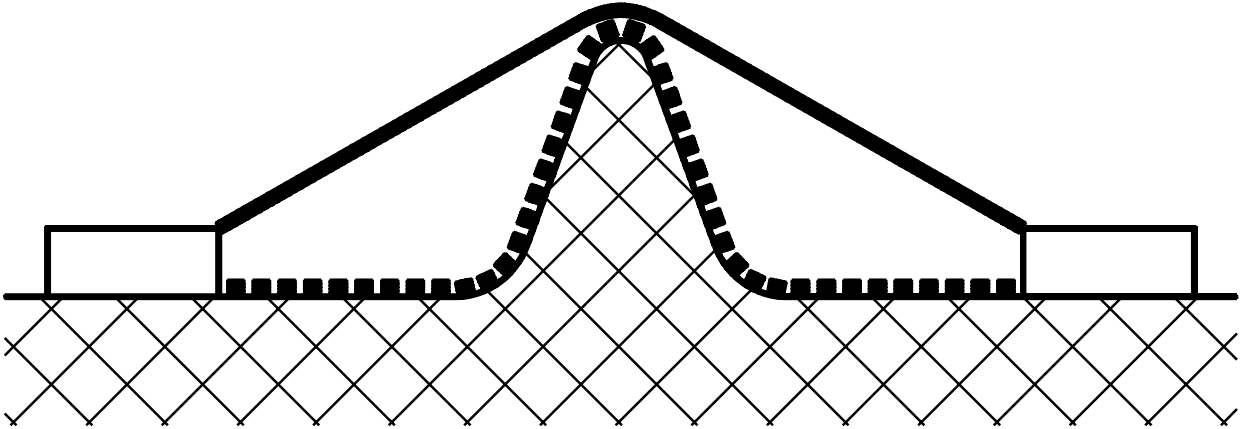

S3412

Condition: Path under consideration includes a rib.

Rule: CLEARANCE is the shortest direct air path over the top of the rib. CREEPAGE DISTANCE path follows the contour of the rib.

Figure E.4 – Rib

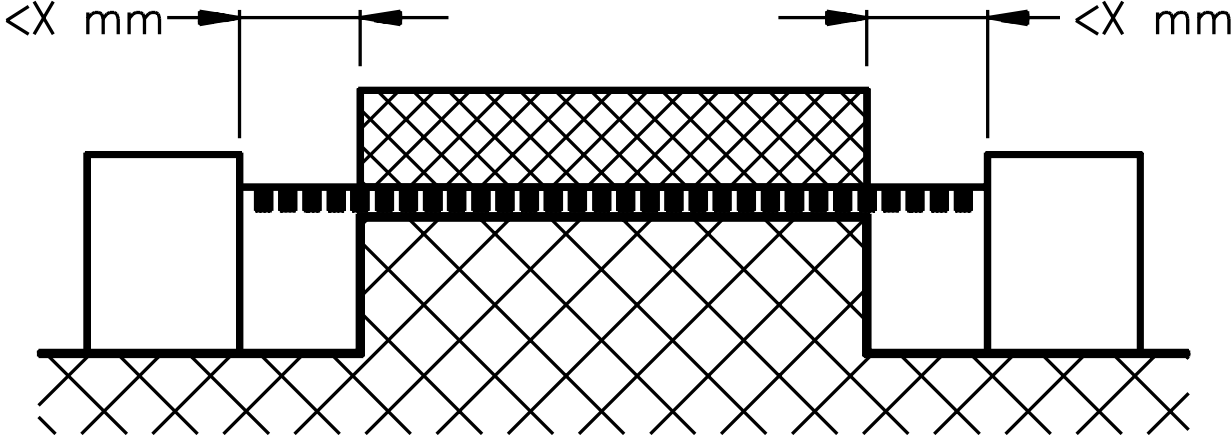

S3413D

Condition: Path under consideration includes an uncemented joint with grooves less than X mm on either side.

Rule: CREEPAGE DISTANCE and CLEARANCE path is the "line-of-sight" distance shown.

Figure E.5 – Uncemented joint with narrow groove

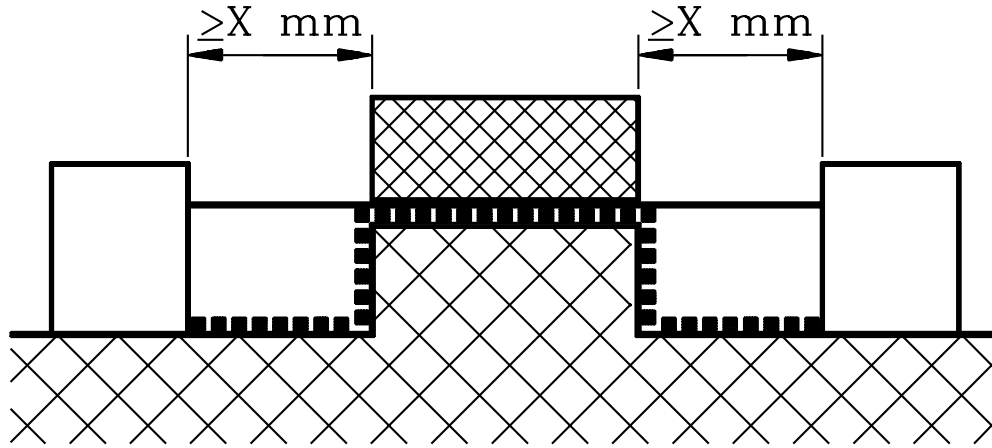

S3414A

Condition: Path under consideration includes an uncemented joint with a groove equal to or more than X mm wide each side.

Rule: CLEARANCE is the "line-of-sight" distance. CREEPAGE DISTANCE path follows the contour of the groove.

Figure E.6 – Uncemented joint with wide groove

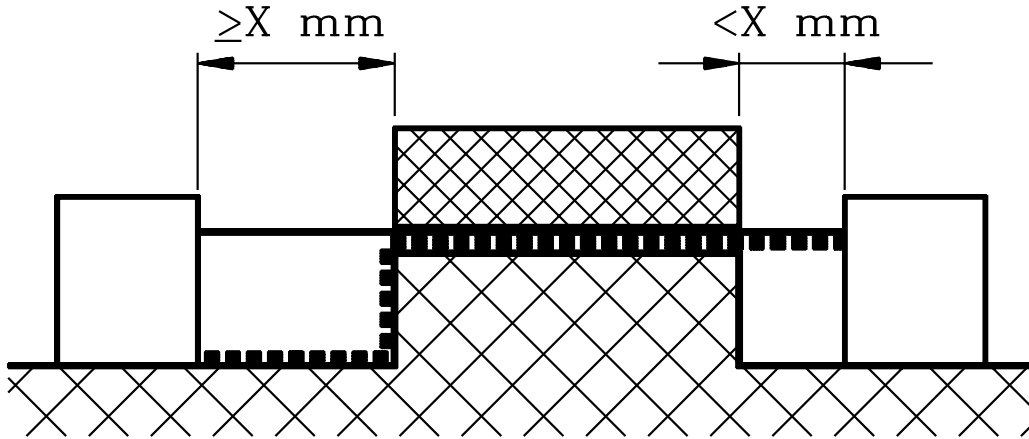

S3415A

Condition: Path under consideration includes an uncemented joint with a groove on one side less than X mm wide and a groove on the other equal to or more than 1 mm wide.

Rule: CLEARANCE and CREEPAGE DISTANCE paths are as shown in figure E.7.

Figure E.7 – Uncemented joint with narrow and wide grooves

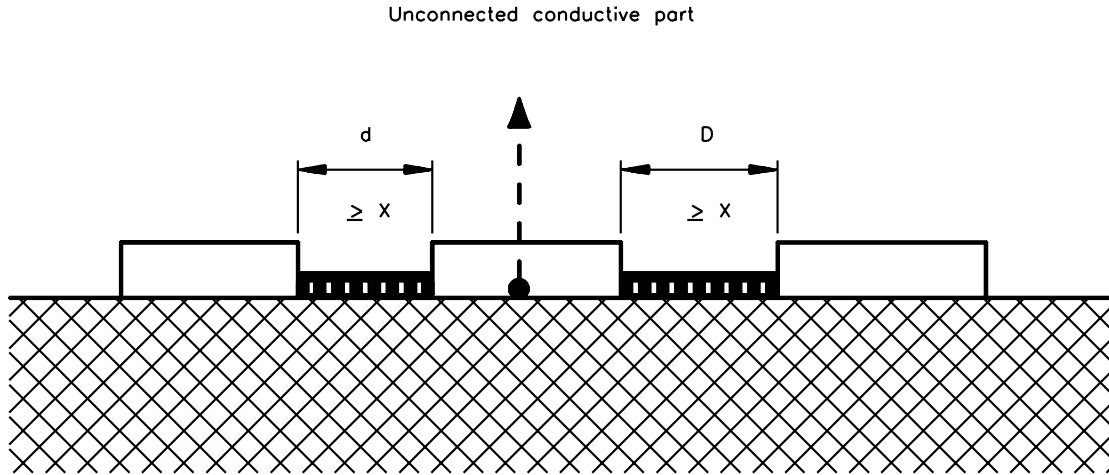

SM1115

Condition: Insulation distance with intervening, unconnected conductive part.

Rule: CLEARANCE is the distance  $d+D$ . CREEPAGE DISTANCE is also  $d+D$ . Where the value of  $d$  or  $D$  is smaller than  $X$  it shall be considered as zero.

**Figure E.8 – Intervening, unconnected conductive part**

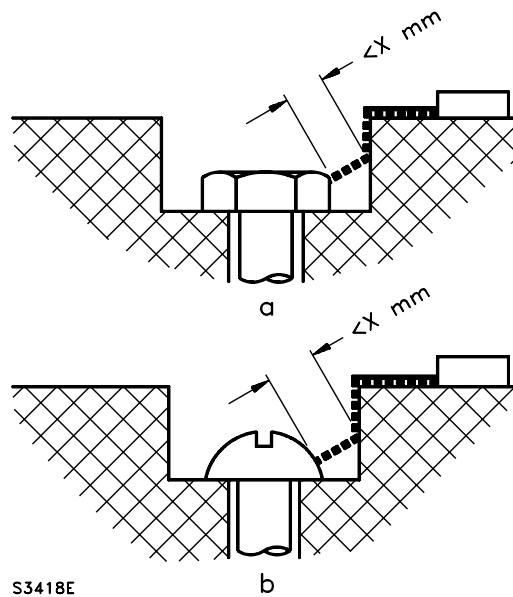

S3418E

Gap between head of screw and wall of recess too narrow to be taken into account.

**Figure E.9 – Narrow recess**

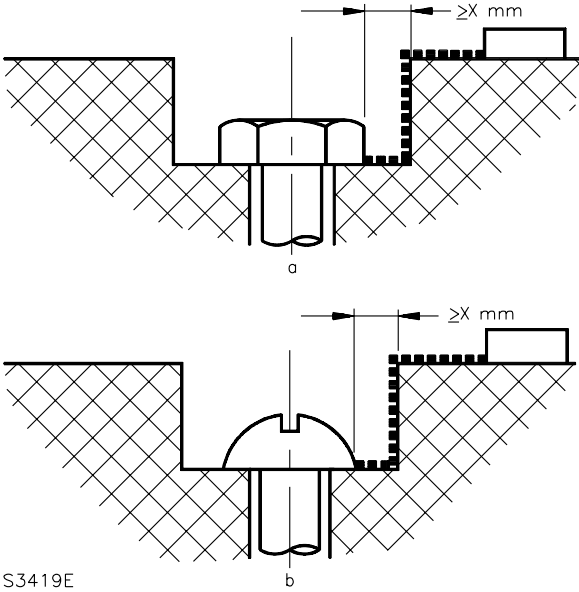

Gap between head of screw and wall of recess wide enough to be taken into account.

**Figure E.10 – Wide recess**



### Annex F (normative) Table of electrochemical potentials

Magnesium, magnesium alloys	Zinc, zinc alloys	80 tin/20 zinc on steel, zinc on iron or steel	Aluminium	Cadmium on steel	Aluminium/magnesium alloy	Mild steel	Duralumin	Lead	Chromium on steel, soft solder	Cr on Ni on steel, tin on steel, 12% Cr stainless steel	High chromium stainless steel	Copper, copper alloys	Silver solder, austenitic stainless steel	Nickel on steel	Silver	Rhodium on silver on copper, silver/gold alloy	Carbon	Gold, platinum	
0	0.05	0.55	0.7	0.8	0.85	0.9	1.0	1.05	1.1	1.15	1.25	1.35	1.4	1.45	1.6	1.65	1.7	1.75	Magnesium, magnesium alloys
	0	0.05	0.2	0.3	0.35	0.4	0.5	0.55	0.6	0.65	0.75	0.85	0.9	0.95	1.1	1.15	1.2	1.25	Zinc, zinc alloys
		0	0.15	0.25	0.3	0.35	0.45	0.5	0.55	0.6	0.7	0.8	0.85	0.9	1.05	1.1	1.15	1.2	80 tin/20 Zinc on steel, zinc on iron or steel
			0	0.1	0.15	0.2	0.3	0.35	0.4	0.45	0.55	0.65	0.7	0.75	0.9	0.95	1.0	1.05	Aluminium
				0	0.05	0.1	0.2	0.25	0.3	0.35	0.45	0.55	0.6	0.65	0.8	0.85	0.9	0.95	Cadmium on steel
					0	0.05	0.15	0.2	0.25	0.3	0.4	0.5	0.55	0.6	0.75	0.8	0.85	0.9	Aluminium/magnesium alloy
						0	0.1	0.15	0.2	0.25	0.35	0.45	0.5	0.55	0.7	0.75	0.8	0.85	Mild steel
							0	0.05	0.1	0.15	0.25	0.35	0.4	0.45	0.6	0.65	0.7	0.75	Duralumin
								0	0.05	0.1	0.2	0.3	0.35	0.4	0.55	0.6	0.66	0.7	Lead
									0	0.05	0.15	0.25	0.3	0.35	0.5	0.55	0.6	0.65	Chromium on steel, soft solder
										0	0.1	0.2	0.25	0.3	0.45	0.5	0.55	0.6	Cr on Ni on steel, tin on steel, 12% Cr stainless steel
											0	0.1	0.15	0.2	0.35	0.4	0.45	0.5	High chromium stainless steel
												0	0.05	0.1	0.25	0.3	0.35	0.4	Copper, copper alloys
													0	0.05	0.2	0.25	0.3	0.35	Silver solder, austenitic stainless steel
														0	0.15	0.2	0.25	0.3	Nickel on steel
															0	0.05	0.1	0.15	Silver
																0	0.05	0.1	Rhodium on silver on copper, silver/gold alloy
																	0	0.05	Carbon
																		0	Gold, platinum

S3426B

NOTE 1 – Corrosion due to electrochemical action between dissimilar metals which are in contact is minimized if the combined electrochemical potential is below about 0.6 V. In the above table the combined electrochemical potentials are listed for a number of parts of metals in common use.

NOTE 2 – See 15.2.

No Text on This Page

**Annex G—DC**  
(normative)  
**Flammability test methods**

NOTE—In Australia and New Zealand special national conditions apply which include tests based on reconciliation with the philosophy of IEC 60695 with respect to glow wire testing, needle flame testing, consequential testing and end product consequential testing.

**G.1**—If no test specimens in accordance with IEC 60707, clause 4 are available, the following test methods may be applied.

*The test is made according to IEC 60695-2-2 on three specimens of end products as used in the apparatus.*

*For the purpose of this standard, the following applies with regard to IEC 60695-2-2:*

*Clause 7—initial measurements; not applicable*

*Clause 8—Test procedure*

*—Subclause 8.2*

*The first sentence is replaced by the following:*

*The test specimens are mounted in such a way as to simulate the conditions obtained when installed in the apparatus.*

*—Subclause 8.4*

*Replace the third paragraph by the following:*

*The test flame is applied to several points of the specimen, so that all critical areas are tested.*

*Clause 9—Observation and measurements.*

*—Subclause 9.2*

*The second paragraph is replaced by the following:*

*Duration of the burning denotes the time interval from the moment the test flame is removed until any flame has been extinguished.*

**G.1.1**—If flammability category FV 0 according to IEC 60707 is required, in addition, the following applies with regard to IEC 60695-2-2.

*Clause 5—Severities*

*The values of duration of application of the test flame are as follows:*

*The test flame is applied for 10 s. If a self-sustaining flame does not last longer than 15 s, the test flame is applied again for 1 min at the same point or at any other point. If again a self-sustaining flame does not last longer than 15 s, the test flame is then applied for 2 min at the same point or at any other point.*

*Clause 10—Evaluation of test results*

*The existing text is replaced by the following:*

*After the first application of the test flame, the test specimens shall not be consumed completely. After any application of the test flame, the duration of the burning of any specimen shall not exceed 15 s, while the average burning time shall not exceed 10 s. The tissue paper shall not ignite and the board shall not scorch.*

**G.1.2** *If flammability category FV 1 according to IEC 60707 is required, in addition, the following applies with regard to IEC 60695-2-2:*

*Clause 5—Severities*

*The values of duration of application of the test flame are as follows:*

*The test flame is applied for 10 s. If a self-sustaining flame does not last longer than 30 s, the test flame is applied again for 1 min at the same point or at any other point. If again a self-sustaining flame does not last longer than 30 s, the test flame is then applied for 2 min at the same point or at any other point.*

*Clause 6—Preconditioning (only applicable to components of 14.4.1)*

*The existing text is replaced by:*

*The specimens are stored for 2 h in an oven at a temperature of  $(100 \pm 2)^\circ\text{C}$ .*

*Clause 10—Evaluation of test results*

*The existing text is replaced by the following:*

*After the first application of the test flame, the test specimen shall not be consumed completely. After any application of the test flame, any self-sustaining flame shall extinguish within 30 s. No burning of the tissue paper shall occur and the board shall not scorch.*

**G.1.3** *If flammability category FV 2 according to IEC 60707 is required, in addition, the following applies with regard to IEC 60695-2-2:*

*Clause 5—Severities*

*The values of duration of application of the test flame are as follows:*

*The test flame is applied for 10 s. If a self-sustaining flame does not last longer than 30 s, the test flame is applied again for 1 min at the same point or at any other point. If again a self-sustaining flame does not last longer than 30 s, the test flame is then applied for 2 min at the same point or at any other point.*

*Clause 10—Evaluation of test results*

*The existing text is replaced by the following:*

*After the first application of the test flame, the test specimen shall not be consumed completely.*

*After any application of the test flame any self-sustaining flame shall extinguish within 30 s.*

**G.1.4** *If flammability category FH 3-40 mm/min according to IEC 60707 is required, the following applies with regard to IEC 60695-2-2:*

*Irrespective of the actual thickness in the apparatus the test is made on test specimens with a thickness of 3 mm.*

NOTE – Test is under consideration.

**G.2** *Compliance of cables and insulation of wires is checked according to IEC 60695-2-2.*

*For the purpose of this standard, the following applies with regard to IEC 60695-2-2.*

**Clause 5 – Severities**

*The values of duration of the application of the test flame are as follows:*

*— first specimen: 10 s*

*— 2second specimen: 60 s*

*— third specimen: 120 s*

**Clause 7 – Initial measurements: not applicable**

**Clause 8 – Test procedure**

*— Add the following to 8.4:*

*The burner is supported so that its axis is in an angle of 45° to the vertical. The cable or wire is held in an angle of 45° to the vertical, its axis being in a vertical plane perpendicular to the vertical plane containing the axis of the burner.*

*— Subclause 8.5 is replaced by the following:*

*The test is made on three specimens taken from each type of cable or wire as used in the apparatus, for example with additional screening and sleeves.*

**Clause 9 – Observations and measurements**

*— Subclause 9.1 does not apply.*

*— Subclause 9.2*

*The second paragraph is replaced by the following:*

*Duration of the burning denotes the time interval from the moment the test flame is removed until any flame has extinguished.*

*Clause 10—Evaluation of the results*

*The existing text is replaced by the following:*

*During the test, any burning of the insulating materials shall be steady and shall not spread appreciably. Any flame shall self-extinguish in 30 s from the removal of the test flame.*

**Annex H DU**  
(normative)

**Safety requirements for video apparatus for use in health care facilities**

The requirements of this standard supplemented or replaced by those contained in this annex apply to video apparatus intended for use in health care facilities.

**H.1.1.1 Signaling and nurse-call feature**

A signaling and nurse-call feature, when provided, shall comply with the applicable requirements in the Standard for Hospital Signaling and Nurse-Call Equipment, UL 1069.

**H.2.2.13**

**HEALTH CARE FACILITY APPARATUS**

An apparatus intended for entertainment purposes for use in a hospital, a nursing home, a medical-care center, or a similar health-care facility in which installation is limited to a nonhazardous area in accordance with the National Electrical Code, ANSI/NFPA 70. It is not intended for use in a critical-care area in which a patient is treated with an externalized electrical conductor, such as a probe, a catheter, or other electrode, connected to the heart; however, the apparatus will be contacted by a patient during his stay in a health-care facility.

**H.4.3.2.1 Burnout test**

*There shall be no emission of flame or molten metal or other adverse effects when all leads of an external cord of a pendant control, pillow speaker, or similar device, which will be subjected to abnormal abuse, are short-circuited. Immediately following the test the touch current is to be measured to determine compliance with the touch current requirements in H.9.1.1.*

*For this test, the supply circuit of the system is to be connected to a source of rated voltage and frequency and the external cord leads short-circuited. The supply circuit is then to be energized and operated until either: burnout occurs or steady-state temperatures are obtained.*

**H.5.2 (d) Receptacle marking**

A receptacle of the conventional parallel-slot type that is not utilized for the connection of a part of an apparatus intended for use in a health care facility shall be marked, where readily visible, to indicate the specific permitted accessory for which it is intended.

**H.5.4.4 Cleaning and disinfecting**

An apparatus shall be constructed so that it is capable of being cleaned or disinfected in accordance with the manufacturer's instructions without increasing the risk of fire, electric shock, or injury to persons.

Unless it is obvious that the enclosure's construction and materials are capable of being used for the cleaning and disinfecting operation called for, a sample of the apparatus shall be subjected to the touch current test described in 9.1.1.

#### **H.5.4.5** DOUBLE INSULATION marking

When the apparatus includes an earthing means in accordance with H.15.2.1, additional wording shall be provided in the marking stating "When grounding of the accessible metal parts is required, a separate grounding lead is to be used."

An apparatus that complies with the requirements for DOUBLE INSULATION and is provided with an earthing conductor in the flexible supply cord in accordance with H.15.2.1 is capable of being permanently marked with the words "DOUBLE INSULATION – EXTERNAL METAL GROUNDED – CAUTION – when servicing use only identical replacement parts."

#### **H.5.4.6** Installation and operation instructions

Operation instructions and installation instructions (when applicable) shall be provided with each apparatus intended for use in a health care facility. The instructions shall include the following information where applicable.

- a) Instructions, including wiring diagrams when required, showing installation of each apparatus. The instructions shall specify that the antenna or cable system connected to an apparatus is to be grounded in accordance with the National Electrical Code, ANSI/NFPA 70.
- b) Specifications on periodic maintenance and servicing of the apparatus.
- c) Cleaning and disinfecting instructions.

#### **H.5.4.7** Unearthed (isolated) parts marking

When an apparatus includes a combination of unearthed – isolated – exposed dead metal parts and earthed dead metal parts that are not exposed during normal use or user servicing, it shall be marked with the word: "CAUTION" and the following or the equivalent: "Accessible metal parts of this apparatus are electrically isolated from the grounding conductor of the supply cord. When grounding of the accessible metal parts is required, a separate grounding lead shall be used."

#### **H.5.4.8** Pendant control

A pendant control that has not been determined to be capable of being used in an oxygen atmosphere shall be marked with the word: "CAUTION" and the following or the equivalent: "Risk of fire when used in oxygen-enriched atmosphere. Keep pendant control away from oxygen equipment."

**H.5.4.8.1** When the pendant control is not provided as part of the apparatus, and the apparatus has a receptacle to accommodate such a control, the marking information in (a) or (b) below is required:

- a) A marking located adjacent to the pendant control receptacle indicating the use of a (specify manufacturer and model number) pendant control that has the marking required by H.5.4.8: or
- b) Marking and installation instructions listed below:
  - 1) A marking located adjacent to the pendant control receptacle consisting of the word "CAUTION" and the following or equivalent: "Risk of fire when pendant control is used in oxygen-enriched atmosphere. Keep pendant control away from oxygen equipment. See marking on pendant control."



2) A statement in the installation instructions consisting of the word "CAUTION" and the following or equivalent: "Installer – This apparatus is not provided with a pendant control; however, it is expected that this institution (or hospital) provides one for attachment to the appropriate receptacle on the apparatus. As part of the installation, examine the pendant control to determine whether a marking similar to the one below appears on it:

'CAUTION – Risk of fire when used in oxygen-enriched atmosphere – return to hook or holder after use'.

When the above notice is not provided on the pendant control, remove the label provided with these instructions and attach it to the pendant control."

3) A separate adhesive-backed label having the marking required by H.5.4.8 that is capable of being affixed by the installer to the pendant control, when required, at the point of installation of the apparatus.

#### **H.7.1.1 Normal temperature test**

##### **Supplements 7.1.1**

An apparatus intended for use in a health care facility shall not reach temperature rises greater than 25°C on an appendage that will be taken into a patient's bed.

#### **H.8.18 Parts touched by patient**

Where one or more electrical insulation breakdowns between adjacent conductive parts – wires, TERMINALS, structural metal, and similar parts – of an apparatus results in available touch current in excess of the limits, the construction shall comply with at least one of the following:

a) For insulated conductive parts, each insulation used shall be rated for the maximum voltage possible – for example, the highest voltage on a part with regard to any exposed conductive part either with or without the introduction of any random breakdown of an insulation involved. A spacing over surface or through air between parts that is not less than 1.5 mm for potentials of 125 V rms or no less than 2.5 mm for potentials of 126 – 250 V rms is capable of being used in place of a single insulation.

b) For two uninsulated conductive parts a spacing between parts that is not less than twice that required in (a) is capable of being used.

c) When not insulated or spaced apart as in (a) or (b), the parts shall be separated by means of a solid insulating (unpierced) barrier, permanently secured in place, properly located, and of integrity such that the barrier is capable of being used as a supplement to conductor insulation.

or in the case of a barrier between two uninsulated parts, satisfies the requirements for REINFORCED INSULATION thereby affording a degree of protection against the risk of electric shock equivalent to that afforded by DOUBLE INSULATION.

In evaluating the required separation of the patient-touched parts from internal circuits, consideration shall be given to the effects of deterioration of insulation, abnormal operation, overload, short-circuit, or component-breakdown conditions.

The patient-touched parts specified above are those parts that will be contacted by the patient while the patient is in bed – for example, a pillow speaker or pendant control for an apparatus taken into bed and operated by the patient, or an apparatus placed near or above the bed and operated by the patient.

#### **H.9.1.1 Touch current test**

All apparatus intended for use in health care facilities shall be evaluated for touch current using the probe in figure 14. The available touch current of an apparatus, based upon its use, shall not exceed the values shown in table H1.

The touch current values specified in table H1 are rms values for dc (nonfiltered rectified ac) and sinusoidal waveforms up to 1 kilohertz. For frequencies above 1 kilohertz the touch current shall not be more than the applicable value specified in table H1 multiplied by the frequency in kilohertz up to a maximum multiplier of 100.

The test meter employed to measure the touch current shall be a high impedance voltmeter with a test circuit that includes the test load, as described in figure H.1, connected across the input TERMINALS. figure H.2 indicates the frequency response characteristics of such a meter-test load combination.

**Table H1**  
**Maximum touch current (mA)**

<u>Type of apparatus</u>	<u>Apparatus construction</u>			
	<u>Earthed</u>		<u>Double insulated</u>	
	<u>AC (rms)</u>	<u>DC</u>	<u>AC (rms)</u>	<u>DC</u>
<u>Apparatus touched by patient, for example, pillow speaker, pendant control, or apparatus located near bed</u>	<u>0.1<sup>a</sup></u>	<u>0.1<sup>a</sup></u>	<u>0.5<sup>a</sup></u>	<u>0.050<sup>a</sup></u>
<u>Apparatus not touched by patient, for example, wall-mounted apparatus</u>	<u>0.5<sup>b</sup></u>	<u>0.7<sup>b</sup></u>	<u>0.25<sup>b</sup></u>	<u>0.35<sup>b</sup></u>
<u>NOTE - When an insulating material is used for the enclosure or part of the enclosure, the touch current is to be measured using a metal foil with an area not exceeding 10 by 20 cm in contact with accessible surfaces for the insulating material. Where the accessible surface of insulating material is less than 10 by 20 cm, the metal foil is to be the same size as the surface.</u>				
<u><sup>a</sup> These touch-current limits apply regardless of the voltage.</u>				
<u><sup>b</sup> These touch-current limits apply only when the open-circuit voltage between the parts in question exceeds 42.4 V peak (30 V rms when the wave form is sinusoidal).</u>				

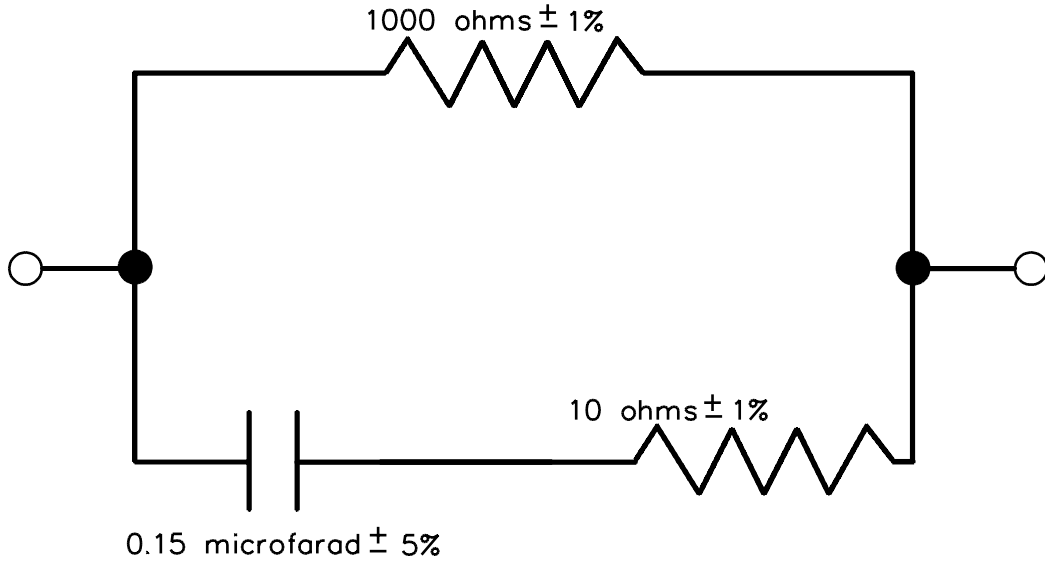

S2472

**Figure H.1**  
**Test load**

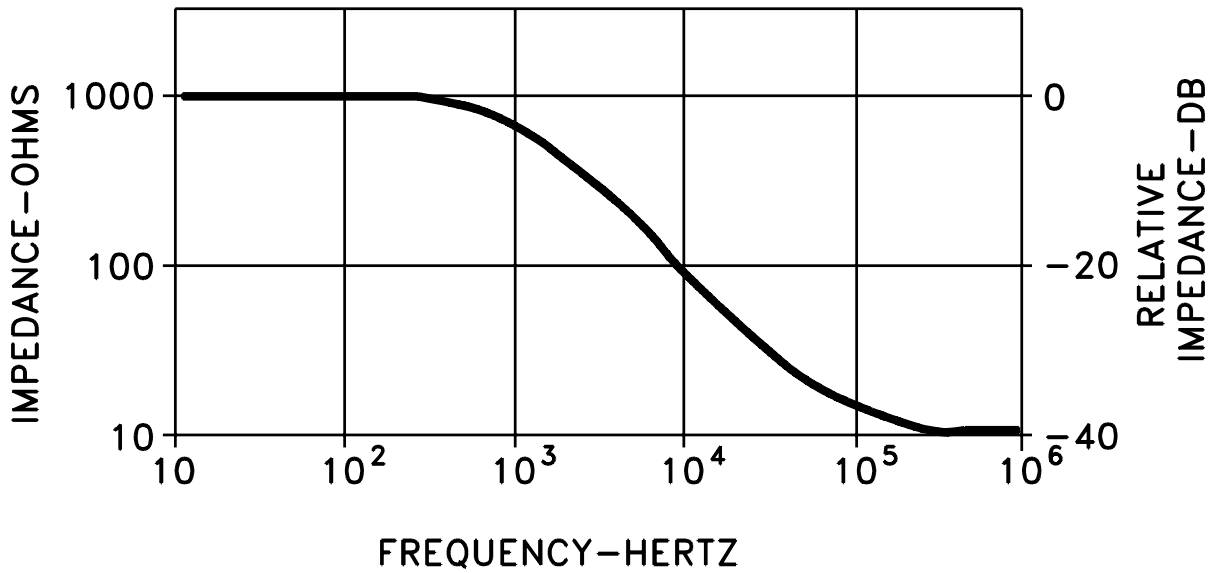

S2473

**Figure H.2**  
**Impedance-frequency characteristics**

### **H.9.1.8 Entry of spilled materials**

Except for wall- or ceiling-mounted type apparatus, an apparatus shall have no opening in any nonvertical surface (top, sloping, and similar surfaces) unless the opening is protected by a barrier that prevents the entrance of a liquid that falls on the area in question from a vertical direction.

### **H.10.2.1 Cleaning test**

Each apparatus or portion of an apparatus that is intended to be cleaned by wiping is to be wiped thoroughly with a folded cheesecloth applicator saturated in the cleaning agent specified by the manufacturer. The complete wiping procedure is to be repeated until a total of 5 operations has been completed after which the touch-current test described in H.9.1.1.

### **H.10.2.2 Immersion test**

An apparatus or appendage of an apparatus that is intended to be taken into the patient's bed shall comply with the touch-current requirements in H.9.1.1 and the dielectric voltage-withstand requirements in H.10.3 after being subjected to the immersion test described below

Each of three samples of the apparatus or appendage is to be immersed for a period of 24 hours in a solution containing 1/2 gram of common table salt per liter of distilled water. Immediately thereafter, the samples are to be subjected to the tests described above.

### **H.10.3 Dielectric voltage-withstand test**

The insulation and spacings for an apparatus shall be capable of withstanding without breakdown for 1 minute the application of the test potentials described below unless an investigation shows that such breakdown does not introduce a risk of fire or electric shock

A 60-Hz sinusoidal potential is to be applied between current-carrying parts conductively connected to the supply circuit and noncurrent-carrying conductive parts, and across each capacitor, winding separation, or other insulation in the primary circuit that is required to reduce the risk of electric shock or, when short-circuited introduces, directly or indirectly, a risk of fire. The test potential is to be:

- a) 1000 V for an apparatus rated 250 V or less and not touched by a patient.
- b) 1000 V plus twice the maximum rated voltage for an apparatus rated more than 250 V or touched by a patient.

When an isolating type of power transformer is used (primary and secondary windings not conductively connected), a 60-Hz sinusoidal potential is to be applied between any current-carrying parts of the primary or power-supply circuit and any current-carrying parts of the secondary circuits. The potential is to be twice maximum rated primary voltage plus 1000 V.

### **H.12.1.3 Impact test**

#### **Supplements 12.1.3**

The top, sides, back, and front of an overall enclosure of a table-, floor-, or wall-mounted apparatus intended for use in a health care facility and used to render LIVE PARTS inaccessible, or to complete the enclosure of parts involving a risk of fire or electric shock, shall withstand a single impact of 7 Joules without developing openings larger than those permitted for fire and electric-shock requirements, resulting in a fire, or causing the apparatus to exceed the touch-current requirements described in H.9.1.1.

#### H.12.1.4 Drop test

##### Supplements 12.1.4

An apparatus or appendage of an apparatus that is intended to be hand-supported shall withstand the drop test described below without exposing LIVE PARTS. Following the drop test, the apparatus shall comply with the touch-current requirements in H.9.1.1.

Each of three samples is to be dropped three times from a height of 1.2 m onto a tile covered concrete surface in the position that will produce adverse results.

H.14.3.4 A transformer connected in the primary circuit intended to supply energy to the low-voltage pendant control shall comply with the requirements for transformers for use with hospital-apparatus pendant controls in the Standard for Transformers and Motor Transformers for Use in Audio-, Radio-, and Television-Type Appliances, UL 1411.

The transformer core shall be earthed unless the insulation between the primary winding and the secondary windings consists of BASIC and SUPPLEMENTARY OR OF REINFORCED INSULATION and if the transformer core is electrically isolated from all secondary windings, secondary circuits, and conductive parts connected to secondary circuits (such as heat sinks and the like).

#### H.14.6.1.1 All-poles switch

Any switch connected in the supply circuit and used as the on-off device shall open all supply circuit conductors simultaneously.

H.14.6.3 The on-off positions on the switch shall be clearly indicated.

H.14.12 A hook or holder shall be provided on the plate to which the pendant control is connected for its support when not in use. An equivalent supporting arrangement is also capable of being used. The hook or holder shall be located on the outside of the bed.

#### H.15.1.1

##### Supplements 15.1.1

Unless an apparatus is CLASS II, an apparatus intended for use in a health care facility shall be provided with a conventional 2-blade with grounding pin attachment plug designated "Hospital Grade".

H.15.2.1 A CLASS I apparatus and its auxiliary equipment also having isolated accessible conductive surfaces that will not become energized from within shall have provision for the earthing of such surfaces by a separate terminal consisting of either a pressure-wire connector or a wire-binding screw. The pressure-wire connector or the wire-binding screw shall be capable of securing a No. 10 AWG (5.3 mm<sup>2</sup>) or smaller earthing conductor.

CLASS II apparatus shall provide a means for earthing accessible conductive surfaces as part of the power supply cord, or by a separate terminal consisting of a pressure-wire connector or a wire-binding screw. The pressure-wire connector or the wire-binding screw shall be capable of securing a No. 10 AWG (5.2 mm<sup>2</sup>) or smaller earthing conductor.

**H.16.1****Supplements 16.1**

The flexible cord shall be Type SJ, SJO, SJT, SJTO, or the equivalent jacketed cord. An oil-resistant cord shall be provided when the apparatus will be subjected to grease or oil. It shall be of a type intended for use at a voltage no less than the rated voltage of the apparatus and shall have an ampacity no less than the current rating of the apparatus.

The length of the supply cord shall not be less than 1.5 m unless installation instructions indicate installation adjacent to a receptacle.

**H.16.5****Supplements 16.5**

A pendant control cord shall be provided with strain relief at each end; for example, at the point of connection to the control and to the plug.

**H.17.8 Wheels and casters**

The wheels or casters on an apparatus or on a cart intended for use with a specific apparatus shall have a minimum diameter of 10 cm.

**H.20.2.4 Pendant-control enclosure**

In a pendant control intended for patient use, current-carrying parts that involve a risk of fire or exceed the touch current limits shall be totally enclosed in an insulated material. The insulating material shall withstand the drop test specified in 12.1.4 and have a flammability classification of V-1 or better as described in the Standard for Tests for Flammability of Plastic Materials for Parts in Devices and Appliances, UL 94. This requirement does not apply to the openings of the enclosure that accommodate functional devices such as switches, speakers, and control-switch knobs. The enclosure shall be marked to caution the user against using the apparatus in an oxygen-enriched atmosphere unless it has been investigated and determined to be capable for that use.

**Annex I DU**  
(normative)  
**Safety requirements for undercabinet apparatus**

The requirements of this standard, supplemented or replaced by those contained in this annex, apply to apparatus intended for undercabinet installation.

**I.2.2.13**

UNDERCABINET APPARATUS

An apparatus intended to be secured to the bottom surface of a cabinet mounted over a countertop.

**I.4.1.4** *For the undercabinet temperature test, elevated ambient test, increased moisture test, and mounting security test, the apparatus shall be mounted in an alcove, as shown in figure I.1, to simulate a typical undercabinet mounting arrangement. The alcove is to be constructed using nominal 19-mm outdoor grade plywood. The underside of the cabinet surface is to be 40 cm above the countertop surface.*

*The apparatus is to be secured to the cabinet surface in accordance with the manufacturer's installation and operating instructions, using tools such as a Phillips or flathead screwdriver or pliers and the required hardware provided by the manufacturer. If special tools are required they are to be supplied by the manufacturer. However, the apparatus is to be located so that it is 30 cm from the side wall (measured from the closest edge of the apparatus). The apparatus is to be located so as to produce the most severe operating condition that the supplied hardware allows.*

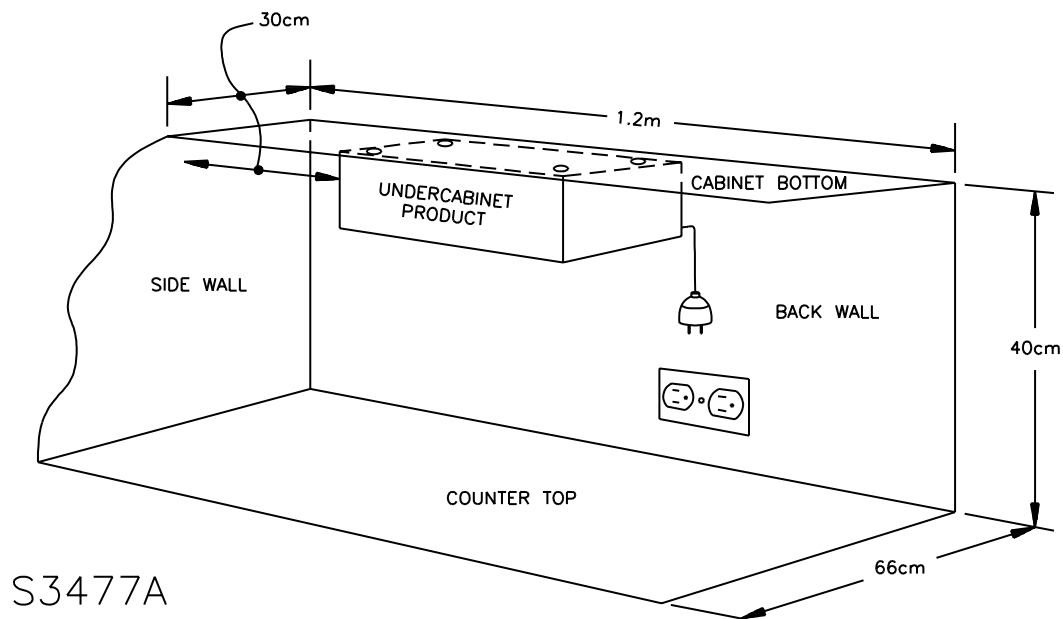

**Figure I.1**  
**UNDERCABINET APPARATUS test set-up**

**I.5.4.3** An UNDERCABINET APPARATUS shall be provided with the following marking in the operation and installation instructions: the signal word "CAUTION" and the following or equivalent wording "To reduce the risk of fire, do not place any heating or cooking apparatus beneath this unit."

**I.10.2** Revise Sub-clause to include the following:

Undercabinet increased moisture and humidity treatment

**I.10.2.1** Undercabinet increased moisture

Following the conditioning described below, an UNDERCABINET APPARATUS shall comply with the requirements specified for apparatus touch current as specified in 9.1.1, and the dielectric strength test described in 10.3.

**I.10.2.2** With the UNDERCABINET APPARATUS mounted as described in I.4.1.4, the apparatus is to be fed by its RATED SUPPLY VOLTAGE; and the apparatus is not to be energized during the test. Touch current measuring equipment is to be connected between accessible metal and earth ground, and adjusted to produce the maximum touch current value. Touch current is to be monitored throughout the duration of the test. An electric kettle is to be used for this test. The kettle is to have a minimum capacity of 1.5 L, a spout opening of 12 – 17 cm<sup>2</sup>, and the spout opening located 12 – 14 cm above the countertop surface. The electric kettle is to be connected to a 60 Hz variable supply circuit adjusted to produce 1500 W of input power and the kettle is to be filled with 1.5 L of tap water. The spout is to be positioned to direct steam towards the bottom center portion of the apparatus, allowing the kettle to boil dry. A final touch current measurement is to be made with the apparatus both energized and unenergized, and recorded when the kettle has boiled off the water. The dielectric strength tests, 10.3, are to be conducted immediately after the final touch current measurement.

**I.11.1.1** Undercabinet elevated ambient

Following the conditioning described below, an UNDERCABINET APPARATUS shall comply with the applicable requirements specified for ACCESSIBLE PARTS in 9.1.1 and the dielectric strength test described in 10.3.

**I.11.1.2** An UNDERCABINET APPARATUS is to be mounted as described in I.4.1.4. When the distance between the bottom surface of the apparatus and the countertop surface is less than 250 mm, the countertop surface is to be adjusted downward so that the distance is 250 mm. When the distance is greater, no adjustment is required.

**I.11.1.3** The apparatus is to be fed by its RATED SUPPLY VOLTAGE and energized. An electric fry pan is to be used as the source of heat for this test. The fry pan is to be rated 1200 W, to have a cooking surface area of 800 – 1000 cm<sup>2</sup>, and to have the cooking surface area located 5.0 – 7.0 cm above the counter top surface. The thermostatic control of the fry pan is to be bypassed and a thermocouple is to be placed in the center of the cooking area of the fry pan with the fry pan located away from the alcove. The fry pan is to be connected to a variable 60 Hz supply circuit adjusted to produce a temperature of 200 ±5°C at the center of the fry pan as measured by the thermocouple. When the temperature has stabilized, the fry pan is to be positioned directly below the UNDERCABINET APPARATUS with the back edge of the fry pan spaced 25 mm from the back wall of the alcove. The fry pan power supply is then to be readjusted to maintain the 200 ±5°C temperature. The test is to be continued for 1-1/2 hours at which time the dielectric strength test is to be conducted while the apparatus is still in the heated condition.

**I.12.1.5.1** Temperature stability test

An UNDERCABINET APPARATUS shall be mounted to the alcove described in I.4.1.4 and the entire alcove is to be placed in the oven.



**I.12.9 Undercabinet mounting stability**

An UNDERCABINET APPARATUS shall withstand a downward vertical force of 90 N for 1 minute following the enclosure temperature stability test described in 12.1.5 when mounted as described in I.4.1.4. Adhesive alone shall not be used to secure the apparatus.

Add to clause 16 – External flexible cords, the following:

**I.16.8 Undercabinet flexible cord routing**

An UNDERCABINET APPARATUS shall be provided with means for routing the power-supply cord and with cord storage or a means so that excess cord does not hang down.

No Text on This Page

**Annex J DU**  
(normative)  
**Safety requirements for in-wall mounted apparatus**

The requirements of this standard, supplemented by those contained in this annex, apply to apparatus intended for in-wall mounting.

**J.2.2.13**

IN-WALL MOUNTED APPARATUS

An apparatus that appears intended for mounting in a wall, has provisions for mounting ears or flanges, or is provided with instructions for mounting in an unfinished wall cavity. The apparatus is placed inside an unfinished wall cavity with some part of the apparatus located behind the plane of the front wall of the wall cavity and in front of the plane of the rear wall of the wall cavity.

Add to clause 5 – Marking and instructions, the following:

**J.5.4.4** An IN-WALL MOUNTED APPARATUS shall be provided with installation and mounting instructions.

**J.5.4.4.1** An apparatus that by construction appears to be intended for in-wall mounting and that is not investigated in accordance with the requirements for IN-WALL MOUNTED APPARATUS shall be marked “Not Suitable For In-Wall Mounting.”

**J.15.5** An IN-WALL MOUNTED APPARATUS intended for connection to the MAINS shall have a means for permanent connection to a wiring system in accordance with the National Electrical Code, ANSI/NFPA 70.

**J.15.5.1** Enclosure requirements for conduit entry

A metal enclosure for an IN-WALL MOUNTED APPARATUS shall have a minimum thickness of 1.35 mm uncoated.

Add to clause 20 – FIRE ENCLOSURE:

**J.20.2.4** The enclosure of an IN-WALL MOUNTED APPARATUS that is located within the wall cavity shall not be provided with unused openings.

**Table J14 – Flammability categories for FIRE ENCLOSURES**

<u>Enclosure material/application</u>	<u>Flammability category</u>
Polymeric	5VA

No Text on This Page

**Annex K DU**  
(normative)  
**Safety requirements for apparatus with projection lamps**

**K.2.7.14**CONDITIONED LAMP

A lamp that has been operated for a minimum of 100 hours.

**K.2.7.15**DEACTIVATED LAMP

A lamp end-of-life failure mode in which the depletion of the filament emission material is such that the lamp gasses are not capable of being ionized. A DEACTIVATED LAMP is to be simulated as follows:

- a) For a rapid-start lamp, two lamps are utilized, each with one end connected to one of the lampholders, and the other end open circuited.
- b) For an instant-start lamp using a circuit-interrupting lampholder, the lamp is removed and the circuit-interrupting lampholder TERMINALS are short-circuited.

**K.2.7.16**HIGH PRESSURE LAMP

A lamp in which the CONTAINED ATMOSPHERIC ENERGY (CAE) equals or exceeds 5 Joules cold (de-energized 50 degrees C or less).

**K.2.7.17**MEDIUM PRESSURE LAMP

A lamp in which the CONTAINED ATMOSPHERIC ENERGY (CAE) is greater than 0.5 Joule and less than 5 Joules.

**K.2.8.13**CONTAINED ATMOSPHERIC ENERGY (CAE)

The amount of energy resulting from the gas contained within a lamp. The CAE is calculated as follows:

$$CAE = 0.15 (PC - PE) V$$

in which:

*PC is the contained pressure in atmospheres.*

*PE is the external pressure in atmospheres, and*

*V is the volume in cubic centimeters.*

**K.2.8.14**INSTANT-START LAMP CIRCUIT

A circuit that uses a high open-circuit voltage to start lamps that usually have a single contact at each end.

**K.2.8.15**LAMP COMPARTMENT

A compartment that encloses a projection lamp. The housing is capable of being metallic or polymeric, and including a lamp diffuser or lens, a metal canopy, a screen, or similar components.

**K.2.8.16**PREHEAT LAMP CIRCUIT

A lamp connected in series with a reactance ballast and the combination in parallel with a manual or automatic starter.

**K.2.8.17**RAPID-START LAMP CIRCUIT

A circuit using continuously heated lamp filaments, along with an open-circuit voltage for the ballast to start the lamp without a starter.

**K.4.3.6** *There shall be no evidence of a risk of fire, electric shock, or injury to persons as a result of separately:*

- a) Simulating belt or blade breakage of a fan or blower assembly that ventilates the lamp.*
- b) Stalling the rotor of a drive motor, fan motor, or similar component.*
- c) Blocking the ventilation path. Ventilating openings that are subject to the accumulation of dust, being placed on a rug, being positioned against drapes, or other similar circumstances are to be covered, one surface at a time, with three layers of cheesecloth loosely draped over the openings, such that the cheesecloth covers 100% of the opening areas.*

*When conducting the tests described above, apparatus that include a projection lamp that is capable of being independently switched on and off shall be tested with the lamp both energized and de-energized. When the lamp burns out during the test, the test is to be continued without replacement of the lamp. A new lamp is to be used for each test.*

**K.4.3.16** Fault tests

*An electric discharge lamp supply circuit shall be subjected to the following tests:*

- a) For a rapid- or instant-start circuit, the test is to be conducted with a DEACTIVATED LAMP.*
- b) For a preheat circuit, the test is to be conducted with either the starter short-circuited, or with a lamp deactivated, so that maximum heating results.*

**K.4.3.16.1** *In the case of a semiconductor component that is capable of being short-circuited and having the lamp supply appear to operate normally, the component shall be separately shorted.*

**K.5.4.4** Cautionary and warning markingsHIGH PRESSURE LAMP

A compartment that houses a HIGH PRESSURE LAMP shall be marked with the word "DANGER" and the following or the equivalent: "HIGH PRESSURE LAMP Involves A Risk Of Explosion And Shall Be Handled In Accordance With Manufacturer's Use Or Installation Instructions. Refer Servicing To Qualified Service Personnel." The marking shall be readily visible during any approach to entering the compartment.

#### **K.5.4.5 Hot surface**

An apparatus having a surface that exceeds the temperature limits of table 2 as specified in K.7.1 shall be marked where readily visible when the surface is exposed to touch with either the word "CAUTION" and the following or the equivalent: "HOT SURFACE" or one of the following symbols shown in figure K.1 (pictorial representation of a hot surface within a triangle).



S4070

**Figure K.1**  
**"HOT SURFACE" symbols**

#### **K.5.4.6 Lamp ultraviolet radiation**

A compartment that houses a user serviceable lamp that produces ultraviolet radiation in excess of the limits specified in K.6.3 shall be marked with the word "WARNING" and the following or the equivalent: "Eye Damage May Result From Directly Viewing The Light Produced By The Lamp Used In This Apparatus. Always Turn Off Lamp Before Opening This Cover." The marking shall be readily visible during any approach to entering the compartment. A compartment provided with an interlock that de-energizes the lamp when the cover is opened is not required to be provided with this marking.

#### **K.5.4.7 Ultraviolet radiation under servicing conditions**

An apparatus that produces ultraviolet radiation in excess of the limits specified in K.6.3 under service personnel servicing conditions shall have the following marking located where readily visible during servicing: "Service Personnel – WARNING" and the following or the equivalent: "Eye Damage May Result From Directly Viewing The Light Produced By The Lamp Used In This Apparatus. Always Turn Off Lamp Before Opening This Cover. Ultraviolet Radiation Eye Protection Required During Servicing."

#### **K.5.4.8 Interlocks**

Apparatus that incorporate an interlock device to reduce the risk of ultraviolet radiation shall be marked where readily visible during any approach to defeat the interlock and with the general location of the interlock indicated. The notice shall consist of the word "WARNING" and the following or the equivalent: "This Cover Is Provided With An Interlock To Reduce The Risk Of Excessive Ultraviolet Radiation. Do Not Defeat Its Purpose Or Attempt To Service Without Removing Cover Completely."

#### **K.5.4.9 Lamp servicing**

A marking shall be provided that identifies the lamp and instructs the user in the proper method of access, removal, installation and provides a user serviceable projection or illumination lamp. Such instructions shall be located where readily visible to the person attempting to use an unintended method of user-servicing. Instructions are not required when the intended method is obvious.

#### **K.6.3 Ultraviolet radiation test**

Apparatus that produce ultraviolet radiation shall comply with the specified guidelines for ultraviolet radiation as specified in the current edition of the Threshold Limit Values and Biological Exposure Indices issued by the American Conference of Governmental Industrial Hygienists.

When determining compliance, all removable parts, such as lenses and filters, that are user serviceable are to be removed from the apparatus when their removal results in an increase in the amount of ultraviolet radiation exposure to the user

#### **K.7.1 Normal temperature test**

An apparatus shall not display temperature rises on surfaces that are exposed to the user, either during normal operation or lamp servicing, greater than those indicated in table 2. The temperature rise limits of table 2 are capable of being exceeded on surfaces within the apparatus that are exposed only during user servicing of a projection lamp when the apparatus is provided with a warning marking as indicated in K.5.4.5.

#### **K.9.1.1 Electric shock test**

During relamping, a user-serviceable fluorescent lamp shall comply with the electric shock requirements in the Standard for Fluorescent-Lamp Ballasts, UL 935.

#### **K.14.5.1.2 Overtemperature-protective devices**

Overtemperature protection that is provided for compliance with the Fault Tests shall consist of one of the following:

- a) Thermal protection complying with the applicable requirements for fluorescent-lamp-ballast protectors in the Standard for Temperature-Indicating and -Regulating Equipment, UL 873.
- b) A thermal cutout complying with the requirements in the Standard for Thermal Cutoffs for Use in Electrical Appliances and Components, UL 1020.
- c) Another protective device that is investigated and determined to provide equivalent protection.



**K.18.1** Lamp rupture test

An apparatus using a medium or HIGH PRESSURE LAMP shall withstand a test (for example, by water or impact) that results in lamp rupture without emission of glass particles other than dust.

When conducting the lamp rupture test, the apparatus is to be mounted in its intended operating position.

**K.20.2.1** LAMP COMPARTMENT

An apparatus intended for use with a medium or HIGH PRESSURE LAMP shall be provided with a LAMP COMPARTMENT. The LAMP COMPARTMENT shall have no holes greater than 3.0 mm diagonally or in diameter. Parts of the LAMP COMPARTMENT where particles from a ruptured lamp will drop and rest shall be of a material as specified below.

A lamp containment barrier at points other than where particles from a ruptured lamp will drop and rest is not prohibited from being provided with open holes greater than 3.0 mm diagonally or in diameter when additional barriers are located such that there is no line-of-sight opening between the arc tube of the lamp and any point external to the apparatus.

The surface of the LAMP COMPARTMENT, where particles from the ruptured lamp will drop to and rest, shall be metal, minimum 3.0 mm thick tempered or borosilicate glass, or metal screen with open holes of maximum 3.0 mm diagonally or in diameter.

A lamp containment compartment of a polymeric material is not prohibited from being used when it complies with the Polymeric Lamp Containment Barrier Test described in the Standard for High Intensity Discharge Lighting Fixtures, UL 1572.

A glass material other than tempered or borosilicate glass is not prohibited from being used when it complies with the Glass Thermal Shock/Containment Test described in UL 1572.

No Text on This Page

**Annex L DU**  
(normative)

**Safety requirements for permanently connected apparatus**

**L.21.1 Supply connections**

**L.21.1.1** Permanently connected apparatus shall be provided with means for permanent connection to the mains supply. Cord connected equipment that is intended to be fastened in place or located in a dedicated space shall be provided with means for permanent connection to the MAINS supply unless connection by means of a supply cord is required to facilitate the interchange of units or removal is required for maintenance and repair, in which case, the shortest feasible length of cord shall be used.

**L.21.1.2** A sheet-metal member to which a wiring system is to be connected in the field shall have a thickness not less than 0.85 mm when of uncoated sheet steel, not less than 0.90 mm when of galvanized sheet steel, not less than 1.15 mm when of sheet aluminum, or not less than 1.10 mm when of sheet copper or sheet brass.

**L.21.1.3** A terminal box or compartment shall be provided in which MAINS supply connections are to be made and shall be such that these connections are capable of being readily made and inspected without disturbing the wiring or the apparatus after the unit is installed as intended.

**L.21.1.4** The volume of a field wiring compartment provided with pigtail leads for connection to the MAINS supply shall not be less than indicated in table L1.

**Table L1**  
**Minimum size of field wiring compartment**

AWG	Size of lead		Wire space within compartment for each lead
		(mm <sup>2</sup> )	(cm <sup>3</sup> )
14		2.1	35
12		3.3	40
10		5.3	45
8		8.4	50
6		13.3	85

**L.21.1.5** A pigtail lead shall not be more than two wire sizes smaller than the MAINS supply conductor to which it will be connected.

For example, when No. 14 AWG (2.1 mm<sup>2</sup>) mains supply conductors are used, the pigtail leads provided shall not be smaller than No. 18 AWG (0.82 mm<sup>2</sup>).

**L.21.1.6** No electrical component shall be mounted on a part, such as the cover of a wiring terminal compartment, that must be removed for the connection or inspection of field wiring. However, this requirement does not apply to a unit in which the power supply circuit wires are intended to be connected to an attachment plug receptacle.

**L.21.1.7** A terminal compartment intended for connection of a supply raceway shall be attached to the unit so that it is resistant to turning.

## L.21.2 Separation of circuits

### L.21.2.1 Field installation of conductors of any circuit shall be separated by barriers:

- a) From field- and factory-installed conductors connected to any other circuit, unless the conductors of both circuits are insulated for the maximum voltage in either circuit, and
- b) From an uninsulated part of any other circuit in the unit and from any uninsulated live part, the short circuiting of which results in a risk of fire or electric shock.

A barrier used to separate the wiring of field and factory wiring shall be held in place and shall be metal or of an insulating material of such strength as to withstand exposure to mechanical damage.

Separation of some field-installed conductors from others and from uninsulated live parts connected to different circuits is capable of being accomplished by arranging the location of openings in the enclosure for the various conductors (with regard to the TERMINALS or other uninsulated live parts) so that the conductors or parts of different circuits are not intermingled.

## L.21.3 Wiring TERMINALS

L.21.3.1 Apparatus intended for permanent connection to the MAINS supply source shall be provided with wiring terminals or leads for the connection of the apparatus to the MAINS supply source. Wiring TERMINALS provided for the connection of conductors shall have a current rating no less than the current rating of the apparatus. A wiring terminal shall be provided with a soldering lug or pressure wire connector, firmly bolted or held by a screw. A fixed wiring terminal shall be prevented from turning.

A wire binding screw is capable of being used at a wiring terminal intended to accommodate a No. 10 AWG (5.3 mm<sup>2</sup>) or smaller conductor when an upturned lug or the equivalent is provided to hold the wire in position.

An upturned lug or a cupped washer shall be capable of retaining a supply conductor not smaller than No. 14 AWG (2.1 mm<sup>2</sup>) under the head of the screw.

L.21.3.2 A field wiring terminal shall be prevented from turning or shifting in position by means other than friction alone. For example, by two screws or rivets, square shoulders, dowel pins, lug offsets, connecting straps or clips fitted into an adjacent part, or some equivalent method.

L.21.3.3 A No. 14 AWG (2.1 mm<sup>2</sup>) conductor is the smallest that is capable of being used for branch-circuit wiring and thus is the smallest conductor that is to be anticipated at a terminal for connection of a branch-circuit conductor.

L.21.3.4 A terminal plate for a wire-binding screw shall be of metal no less than 1.5 mm in thickness and shall have no less than two full threads in the metal.

A terminal plated formed from stock having the minimum required thickness as given above is capable of having the metal extruded at the tapped hole for the binding screw so as to provide two full threads.

L.21.3.5 The free length of a lead inside an outlet box or wiring compartment shall be 150 mm or more when the lead is intended for field connection to an external circuit.

L.21.3.6 PERMANENTLY CONNECTED APPARATUS rated at 125 or 125/250 V (3-wire) or less shall have one TERMINAL or lead identified for the connection of the grounded circuit conductor (neutral) of the power supply circuit.

A field-wiring TERMINAL intended for the connection of a grounded circuit conductor (neutral) shall be identified by means of a metallic coating that is substantially white in color and be easily distinguishable from the other TERMINAL; or proper identification of the TERMINAL for the connection of the grounded TERMINAL shall be clearly shown in some other manner, such as an attached wiring diagram. When wire leads are provided instead of TERMINALS, the identified lead shall have a white or natural gray color and shall be easily distinguishable from the other leads.

When a lampholder is provided, the identified TERMINAL or lead shall be connected to the screw shell of the lampholder. A fuse or single-pole switch, circuit breaker, or automatic control shall not be connected to the identified grounded circuit conductor (neutral).

L.21.3.7 The distance between any pressure TERMINAL connector intended for field wiring and the wall of the enclosure toward which the conductor is directed or through which the conductor is intended to pass shall be as indicated in table L2. However, the distance is capable of being less where the wall or other obstruction lies outside of the area occupied by the conductor that is bent or deflected to a radius not less than the distance given in the Table.

**Table L2**  
**Minimum wire bending space**

Size of wire.		Minimum bending space – terminal to wall.
AWG	(mm <sup>2</sup> )	mm
14 – 10	2.1 – 5.3	Not specified
8 – 6	8.4 – 13.3	40
4 – 3	21.2 – 26.7	55
2	33.6	65
1	42.4	80

L.21.3.8 A field-wiring TERMINAL or lead for the connection of an apparatus grounding conductor shall be provided.

L.21.3.9 A field-wiring TERMINAL or lead for the connection of an apparatus grounding conductor shall be a screw type connector capable of securing a conductor of the proper size.

L.21.3.10 A wire-binding screw or screw-type wire connector shall be located so that it will not be removed during the intended servicing of the apparatus, and the wire-binding screw intended for the connection of the apparatus grounding conductor shall have a green colored head that is hexagonal, slotted, or both. A screw-type pressure-wire connector intended for such a conductor shall be plainly marked with the symbol ⊕.

L.21.3.11 The surface of an insulated lead intended solely for the connection of an apparatus grounding conductor shall be green with or without one or more yellow stripes, and no other lead shall be so color coded.

The requirement above covers the color coding of grounding leads of internal wiring which is visible in a wiring compartment in the area in which field connections are to be made. The requirement does not apply to leads or wiring of low voltage circuits that are intended to be field connected to CLASS 2 wiring and that are separated or segregated from high voltage circuit field wiring connections by barriers.

#### L.21.4 Spacings at field-wiring TERMINALS

L.21.4.1 The spacing between field wiring TERMINALS of opposite polarity, and the spacing between a wiring terminal and any other uninsulated metal part not of the same polarity, shall not be less than that specified in table L3.

**Table L3**  
**Spacings at wiring TERMINALS**

Potential involved, volts	Minimum spacings		
	Between wiring terminals, through air or over surface	Between terminals and other uninsulated metal parts not always of the same polarity <sup>a</sup>	
		Over surface	Through air
	mm	mm	mm
250 or less	6.5	6.5	6.5
more than 250	13	13	10

<sup>a</sup> Applies to the sum of the spacings involved where an isolated dead metal part is interposed.

#### L.21.5 Earth connections in PERMANENTLY CONNECTED APPARATUS

L.21.5.1 A screw-type pressure-wire connector intended for connection of the apparatus earthing conductor shall be plainly identified by the marking "G", "GR", "Ground", "GND", "Grounding" or the symbol ⊕, or a similar designation, or by a marking on a wiring diagram provided on the apparatus.

#### L.21.6 Supply wire temperature ratings

L.21.6.1 Apparatus for which, during the temperature test, the wires within a terminal box or MAINS wiring compartment attain a temperature higher than 60°C, shall be marked with the following or the equivalent: "For supply connections use wires rated for \_\_\_\_\_ °C minimum." The temperature to be used in the marking shall be 75 or 90 as appropriate.

#### L.21.7 Different conductor materials

L.21.7.1 Apparatus incorporating MAINS field wiring TERMINALS shall be marked where visible during and after installation with "Use Aluminum Conductors Only" when the terminal is intended only for connection to aluminum wire or "Use Copper or Aluminum Conductors" when the terminal is intended for connection to both copper and aluminum wire.

**Annex M DU**  
(normative)

**Safety requirements for carts, stands, and similar apparatus for use with specific apparatus covered by this standard**

**M.5.1** A cart or stand that is specified by the manufacturer for use with an apparatus and that is packaged and marketed separately from the apparatus shall be marked with the cart or stand manufacturer's name, a distinctive catalog designation, and with the word "CAUTION" and the following or the equivalent: "This cart (or stand) intended for use only with (manufacturer's name) model number (or series) (apparatus name). Use with other apparatus is capable of resulting in instability causing possible injury."

**M.5.4** When it is not feasible to include a specific apparatus model number series designation in the cart or stand marking as required in M.5.1, the cart or stand shall be marked as follows: "CAUTION – This cart (or stand) for use only with specific (manufacturer's name) (apparatus). See apparatus instructions. Use with other models is capable of resulting in instability causing possible injury."

In conjunction with the markings described above, an apparatus intended for use with this cart or stand shall be marked as follows: "CAUTION – This (apparatus name) for use only with (cart or stand manufacturer's name and model number) cart (or stand). Use with other carts (or stands) is capable of resulting in instability causing possible injury." This marking shall be located on a readily visible part of the apparatus or on literature packed with it.

**M.12.9** Injury to persons tests

*All apparatus shall be subjected to the applicable tests described in the following Sub-clauses. An apparatus shall be subjected to the applicable tests alone and again while placed on any cart or stand that is provided or specified by the apparatus manufacturer.*

*When polymeric materials are involved in the construction, the applicable tests described in M.12.9.2 – M.12.9.5 shall be conducted both before and after the test described in ble tests described in M.12.9.1.*

**M.12.9.1** Apparatus, cart, or stand temperature stability

*An apparatus, cart, or stand using polymeric materials in its construction shall withstand either of the conditions described in 12.1.5 without any shrinkage, warpage, or other distortion of the polymeric materials that results in the apparatus, cart, or stand not complying with requirements in this Sub-clause.*

*During the test, an apparatus intended for use with a companion cart or stand shall be tested with the apparatus placed on the cart or stand in accordance with the instructions provided by the manufacturer.*

**M.12.9.2** Wheel or caster securement

*A wheel or caster shall be capable of withstanding a pull of 20 N without being damaged or pulled free from its securing means.*

*The pull force is to be applied by a weight, or a steady pull, for a period of 1 minute in any direction made possible by the construction.*

### **M.12.9.3 Cart or stand loading**

A cart or stand intended for floor mounting shall be constructed so that permanent deformation or damage that is capable of resulting in injury to persons does not occur when it is subjected to a weight that exerts a force of 220 N applied for 1 minute to any appurtenance accessible to a child.

To determine compliance, the force is to be applied through the end of a 5-cm diameter right circular cylinder. The force is to be applied to a shelf, drawer, dowel rung support, or equivalent part that is within 75 cm of the floor and will support some or all of a child's weight. The force is to be applied for 1 minute with the cart or stand at room temperature. The part is not to collapse or break so as to expose sharp edges or produce pinch points that are capable of resulting in injury.

In addition, a cart or stand intended for floor mounting shall be constructed so that permanent deformation or damage that is capable of resulting in injury to persons does not occur when each shelf or drawer is individually subjected to a weight that exerts a force of four times the manufacturer's intended loading.

To determine compliance, the test weight is to be:

- a) Four times the specific apparatus load or 450 N, whichever is greater, for the top shelf.
- b) Four times the specific apparatus load, four times the manufacturer's intended load, or 450 N, whichever is greater, for other shelves of the cart or stand which are intended to support an apparatus
- c) Four times the manufacturer's intended load, or 100 N, whichever is greater, for a shelf or drawer not intended to support an apparatus, such as tape and accessory storage areas.

The weight is to be applied for 1 minute with the cart or stand at room temperature. When polymeric materials are involved in the construction of the cart or stand, the test is to be conducted before and after the test described in 12.1.5.

### **M.12.9.4 Cart or stand impact test**

When tested as described below, a cart or stand shall not produce a risk of injury to persons.

A single 7.0 Joule impact is to be applied to any part of the cart or stand and the test method is to be as described in 12.1.3.

### **M.12.9.5 Cart or stand handle strength test**

When tested as described in 12.1.6, a handle or support system of a cart or stand shall not break nor shall there be any breakage of the securing means, including that portion of the enclosure to which the handle or support system is attached.

A cart or stand handle or support system shall withstand a force of twice the combined weight of the cart or stand and the apparatus.

### **M.12.9.6 Mounting means test**

The rack, wall, ceiling, or other mounting provisions and hardware supplied with the apparatus shall be subjected to a force four times the weight of the apparatus. There shall be no cracking, breaking, or detaching of the securing means or of the portion of the enclosure to which the mounting means are attached when tested as described below.



**M.19 Mechanical stability**

A cart or stand, or a cart or stand used in combination with its intended apparatus shall be subjected to the applicable tests described in the following Sub-clauses.

During these tests, the apparatus or the cart or stand shall not overbalance, nor shall the apparatus be dislodged when tested in combination with the cart or stand.

**M.19.1** The cart or stand alone, and the cart or stand in combination with its intended apparatus is placed in its normal position of use on a plane inclined at an angle of 10° to the horizontal and rotated slowly through an angle of 360° about its normal vertical axis.

**M.19.1.1** For the test, the cart or stand alone, and the apparatus in combination with the cart or stand is to be placed on a non-skid surface and arranged in its intended position with all doors, drawers, casters, wheels, adjustable feet (levelers) and other appurtenances positioned in any combination that results in the least stability. Legs and other means of support are not prohibited from being blocked to keep the cart or stand from sliding.

**M.19.2** A force of 100 N directed vertically downwards is applied in such a way as to produce the maximum overturning moment, to any point of any horizontal surface, protrusion or recess, provided that the distance of that point to the floor does not exceed 75 cm.

**M.19.3** When positioned as described in M.19.1.1, an apparatus having a mass of 25 kg or more, that is used in combination with a cart or stand, is subjected to an externally applied horizontal force of 13% of the weight of the apparatus, or 90 N, whichever is less. The force is to be applied in a horizontal direction to that point on the apparatus that will result in the least stability of the apparatus and is not to be applied more than 1.5 m above floor level.

No Text on This Page

**Annex N**  
(informative)  
ROUTINE TEST

## INTRODUCTION

The tests given in this annex are intended to reveal, as far as safety is concerned, unacceptable variations in material or manufacture. These tests do not impair the properties and the reliability of the apparatus, and should be made by the manufacturer on each apparatus during or at the end of the production.

In general, more tests, such as repetition of TYPE TESTS and sampling tests, have to be made by the manufacturer to ensure that every apparatus is in conformity with the sample that withstood the TYPE TEST of this standard, according to experience gained by the apparatus manufacturer.

The manufacturer may use a test procedure which is better suited to his production arrangements and may make the tests at an appropriate stage during production, provided it can be proved that apparatus which withstand the tests carried out by the manufacturer provide at least the same degree of safety as apparatus that withstand the tests specified in these annex.

NOTE – Generally, an appropriate quality assurance system should be employed, for example according to the ISO 9000 series [15].

The following rules are given as an example for ROUTINE TEST:

### **N.1 Tests during the production process**

#### **N.1.1 Correct polarity and connection of components or subassemblies**

If incorrect polarity or connection of components or subassemblies might result in a safety hazard, the correct polarity and connection of these components or subassemblies should be checked by measurement or inspection.

#### **N.1.2 Correct values of components**

If incorrect values of components might result in a safety hazard, the correct value of these components should be checked by measurement or inspection.

#### **N.1.3 Protective earth connection of screens and metal barriers**

For CLASS I apparatus with a screen or metal barrier (see 8.5) between HAZARDOUS LIVE parts and TERMINALS regarded as ACCESSIBLE (see 8.4) or ACCESSIBLE conductive parts respectively, the continuity of the protective earth connection should be checked as late as possible during the production process between the screen or metal barrier and

- the protective earth contact of the MAINS plug or appliance inlet, or
- the PROTECTIVE EARTH TERMINAL in case of a PERMANENTLY CONNECTED APPARATUS.

The test current applied for 1 s to 4 s should be in the order of 10 A a.c., derived from a source having a no-load voltage not exceeding 12 V.

The measured resistance should not exceed

- 0.1  $\Omega$  for apparatus with a detachable power supply cord,
- 0.2  $\Omega$  for apparatus with a non-detachable power supply cord.

NOTE – Care should be taken that the contact resistance between the tip of the measuring probe and the metal parts under test does not influence the test results.

#### **N.1.4 Correct position of internal wiring**

If incorrect position of internal wiring might impair the safety, the correct position of internal wiring should be checked by inspection.

#### **N.1.5 Correct fit of internal plug connections**

If incorrect fit of internal plug connections might impair the safety, the correct fit of internal plug connections should be checked by inspection or manual test.

#### **N.1.6 Safety relevant markings inside the apparatus**

The legibility of markings relevant to safety inside the apparatus, for example with regard to fuse-links, should be checked by inspection.

#### **N.1.7 Correct mounting of mechanical parts**

If incorrect mounting of mechanical parts might impair the safety, the correct mounting should be checked by inspection or manual test.

### **N.2 Tests at the end of the production process**

The following tests should be made on the apparatus when completely assembled and just before packing.

#### **N.2.1 Dielectric strength test**

The insulation of the apparatus should be checked by the following tests. In general, these tests are considered to be sufficient.

An a.c. test voltage of substantially sine-wave form, having MAINS frequency, or a d.c. test voltage or a combination of both with a peak value specified in table N1, is applied between the MAINS supply TERMINALS connected in parallel and:

- TERMINALS regarded as ACCESSIBLE (see 8.4), and
- ACCESSIBLE conductive parts respectively,

which may become HAZARDOUS LIVE in the event of an insulation fault as a result of incorrect assembly.

NOTE 1 – TERMINALS regarded as ACCESSIBLE and ACCESSIBLE conductive parts may be connected together during the dielectric strength test.

Before the test voltage is applied, intimate contact should be made with the specimen.

Initially, not more than half of the prescribed test voltage is applied, then it is raised with a steepness not exceeding 1560 V/ms to the full value which is held for 1 s to 4 s.

NOTE 2 – A steepness of 1560 V/ms corresponds to the steepness of a sine-wave with a MAINS frequency of 60 Hz.

During the test, MAINS switches and functional switches, if any, CONDUCTIVELY CONNECTED TO THE MAINS, should be in the on-position and it should be secured by suitable means so that the test voltage is completely effective.

No flash-over or breakdown should occur during the test. The test voltage source should be provided with a current sensing (over-current) device which, when activated, gives an indication that the test has been failed. The test voltage source should still deliver the prescribed voltage until current tripping occurs.

NOTE 3 – The tripping current should not exceed 100 mA.

NOTE 4 – Tripping of the current sensing device is regarded as a flash-over or breakdown.

**Table N1 – Test voltage**

Application of test voltage	Test voltage V (peak) a.c. or d.c.	
	Rated MAINS voltage ≤ 150	Rated MAINS voltage > 150
BASIC INSULATION	1130 (800 r.m.s.)	2120 (1500 r.m.s.)
DOUBLE OR REINFORCED INSULATION	2120 (1500 r.m.s.)	3540 (2500 r.m.s.)

**N.2.2 Protective earth connection**

For CLASS I apparatus, the continuity of the protective earth connection should be checked between the protective earth contact of the MAINS plug or appliance inlet, or the PROTECTIVE EARTH TERMINAL in case of a PERMANENTLY CONNECTED APPARATUS, and

- the ACCESSIBLE conductive parts, including TERMINALS regarded as ACCESSIBLE (see 8.4), which should be connected to the PROTECTIVE EARTH TERMINAL, and
- the protective earth contact of socket-outlets respectively, if provided to deliver power to other apparatus.

The test current applied for 1 s to 4 s should be in the order of 10 A a.c., derived from a source having a no-load voltage not exceeding 12 V.

The measured resistance should not exceed

- 0.1 Ω for apparatus with a detachable power supply cord,
- 0.2 Ω for apparatus with a non-detachable power supply cord.

NOTE – Care should be taken that the contact resistance between the tip of the measuring probe and the conductive parts under test does not influence the test results.

### **N.2.3 Safety relevant markings on the outside of the apparatus**

The legibility of safety relevant markings on the outside of the apparatus, for example with regard to the supply voltage, should be checked by inspection.

**Annex O DE**  
**Reserved for future use**

No Text on This Page



**Annex P**  
(informative)  
**Bibliography**

- [1] IEC 60083:1997, *Plugs and socket outlets for domestic and similar general use standardized in member countries of IEC*
- [2] IEC 60130 (all parts), *Connectors for frequencies below 3 MHz*
- [3] IEC 60169 (all parts), *Radio-frequency connectors*
- [4] IEC 60173:1964, *Colours of the cores of flexible cables and cords*
- [5] IEC 60260:1968, *Test enclosures of non-injection type for constant relative humidity*
- [6] IEC 60335-2-56:1997, *Safety of household and similar electrical appliances – Part 2: Particular requirements for projectors and similar appliances*
- [7] IEC 60335-2-82, – *Safety of household and similar electrical appliances – Part 2: Particular requirements for service machines and amusement machines<sup>1)</sup>*
- [8] IEC 61040:1990, *Power and energy measuring detectors, instruments and equipment for laser radiation*
- [9] IEC Guide 104:1997, *The preparation of safety publication, and the use of basic safety publications and group safety publications*
- [10] IEC Guide 108:1994, *The relationship between technical committees with horizontal functions and product committees and the use of basic publications*
- [11] IEC Guide 109:1995, *Environmental aspects – Inclusion in electrotechnical product standards*
- [12] ISO/IEC Guide 37:1995, *Instructions for use of products of consumer interest*
- [13] ISO/IEC Guide 51:1990, *Guidelines for the inclusion of safety aspects in standards*
- [14] ISO 1043-1:1997, *Plastics – Symbols and abbreviate terms – Part 1: Basic polymers and their special characteristics*
- [15] ISO 9000 (all parts), *Quality management and quality assurance standards*
- [16] ICRP 15:1969, *Protection against ionizing radiations from external sources – Published by the International Commission on Radiological Protection*
- [17] UIT-T Rec. K.11:1993, *Principles of protection against overvoltages and overcurrents*
- [18] IEC 60695 – *Fire hazard testing*

<sup>1)</sup> To be published

No Text on This Page

**Annex Q DU**  
(informative)

**A 0.02-ohm shunt for use in the peak inrush-current measurement described in 14.6.11.1**

**Q.21.1 Purpose**

Q.21.1.1 This annex provides the construction details for a 0.02-ohm, high-frequency, current-viewing, resistive shunt that complies with the specifications given in table Q1 and is capable of being used for conducting the Peak Inrush-Current Test, 14.6.11.1. It is capable of being fabricated with ordinary tools, and uses readily available parts. Commercial shunts having the prescribed characteristics are also available.

**Table Q1**  
**Specifications for the high-frequency, current-viewing, resistive shunt used for measuring apparatus peak inrush current**

<u>Parameter</u>	<u>Specification</u>	<u>Tolerance</u>
<u>Resistance</u>	<u>0.02 ohms</u>	<u>± 2.5 percent</u>
<u>Rise Time</u>	<u>30 nanoseconds<sup>a</sup></u>	<u>plus 0; minus not specified</u>
<u><sup>a</sup> When a peak-to-peak pulse of any convenient value having a rise time of 30 nanoseconds or less is applied, there is to be no discernible rise-time degradation of the applied waveform when viewed from the current-viewing connector.</u>		

**Q.21.2 General**

Q.21.2.1 The construction details for the 0.02-ohm shunt are given in figure Q.1 and its accompanying text.

Q.21.2.2 When using the shunt for the measurement of the Peak Inrush-Current Test, the exact resistance of the finished shunt is to be used, as determined by resistance-measurement equipment accurate to at least 0.001 ohm, in all calculations and calibrations.

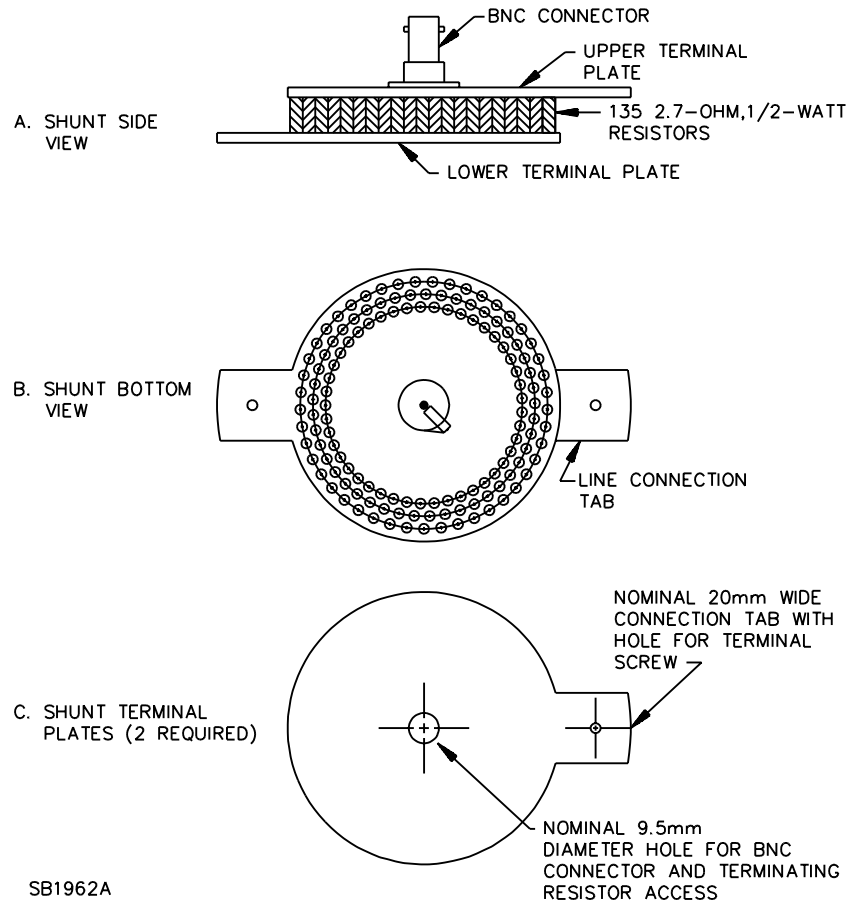

#### PARTS LIST AND ASSEMBLY SPECIFICATIONS

1. One hundred and thirty-five 2.7-ohm, 1/2-W carbon composition resistors,  $\pm 5\%$  tolerance.
2. Two 86-mm diameter, nominal 1.0-mm thick sheet-copper plates cut as shown in item C.
3. Resistors mounted between the two plates on three concentric circles as shown in items A and B.
  - I) Outer
  - II) Center circle 7 cm diameter.
  - III) Inner circle 6 cm diameter.
4. One BNC-type coaxial cable connector mounted in a hole in the upper terminal plate as shown in item A.
5. The cable-connector shield is fastened to one plate. The center contact of the connector is fastened to the other plate through a terminating resistor matching the cable impedance (33 – 50 ohms).

**Figure Q.1**  
**Construction details for a high-frequency, current-viewing, resistive shunt satisfying the specifications in table Q1**

**Annex R DU**  
(normative)  
**Manufacturing and production-line tests and verifications**

The following tests are to be conducted by the manufacturer during or at the end of production.

**R.21.1 Production-line dielectric voltage-withstand test**

*Each apparatus shall withstand as a routine production-line test the application of a potential not less than that shown in either Table R1A for CLASS I apparatus or Table R1B for CLASS II apparatus without an indication of noncompliance. At the manufacturer's option, the a.c. test potential may be conducted at a potential of 5/6 of the voltage specified with the duration of the application increased to 60 seconds.*

*The test is not required to be made on speakers and similar components mounted in cabinets made of wood or other nonconductive material when the components are not touched or handled in the use of the apparatus and when their mounting screws, or the equivalent, are not exposed on the exterior of the cabinet.*

*The test is to be conducted when the apparatus is complete and ready for packing, or when it is complete except for parts such as snap covers or friction-fit knobs that interfere with the performance of the test. For the test, the apparatus is capable of being in the heated or unheated condition.*

*The test equipment is to include:*

*a) A means for indicating the test voltage that is being applied to the apparatus being tested. This is to be accomplished by sensing the voltage at the test leads, or by an equivalent means.*

*b) A means for effectively indicating noncompliance. The indication is to be auditory when it is capable of being readily heard above the background noise level, visual when it commands the attention of the operator, or a device that automatically rejects noncompliant apparatus. When the indication of noncompliance is auditory or visual, the indication is to remain active and conspicuous until the test equipment is reset manually.*

*There is to be no transient voltage applied to the apparatus being tested that results in an instantaneous voltage to the apparatus exceeding 120% of the peak value of the test voltage that the manufacturer specifies for this test. This requirement applies for the entire duration of the test, including the time that the voltage is first applied to the apparatus and the time that the voltage is removed from the apparatus.*

*The control of the applied voltage specified in these requirements, whether manual or automatic, is to be maintained under conditions of varying line voltage. Higher test potentials are to be used only when the higher dielectric stress will not adversely affect the insulating systems of the apparatus.*

Revised R.21.1 effective January 31, 2003

**Table R1**  
**Production-line dielectric voltage withstand test potential for products marked with the DOUBLE**  
**INSULATION symbol**

Table R1 deleted effective January 31, 2003

**Table R1A**  
**Dielectric voltage-withstand test potentials for CLASS I (earthed) apparatus**

Added Table R1A effective January 31, 2003

Apparatus voltage rating	Test potential, V (40 – 70 Hz)	Test potential, V dc	Time, seconds
130 V rms (184 V dc) or less	800	1130	1
Greater than 130 V rms (184 V dc)	1500	2120	1

**Table R1B**  
**Dielectric voltage-withstand test potentials for CLASS II (double insulated) apparatus**

Added Table R1B effective January 31, 2003

Apparatus voltage rating	Test potential, V (40 – 70 Hz)	Test potential, V dc	Time, seconds
130 V rms (184 V dc) or less	1500	2120	1
Greater than 130 V rms (184 V dc)	2500	3540	1

#### **R.21.2 AC production-line test**

When adjusted for production-line testing, an ac tester is to have the following features and characteristics:

- a) The test equipment is to produce an output voltage that has a sinusoidal waveform, a frequency that is within the range of 40– 70 Hz, and a peak value of the waveform that is no less than 1.3 and no more than 1.5 times the root-mean-square value.

b) The test equipment is to produce an output voltage that is no less than the value specified, nor is the magnitude of the test voltage to be greater than 120% of the specified potential when the tester is used in each of the following conditions:

1) When the test duration is 1 second, the output voltage is to be maintained within the specified range when only a voltmeter having an input impedance of at least 2 megohms and a specimen of the apparatus being tested are connected to the output terminals, and when a resistance of no less than 2 megohms is connected in parallel with the voltmeter and the apparatus being tested, and the value of the resistance is reduced in increments that are no greater than 25% of the preceding value to the point at which an indication of unacceptable performance just occurs.<sup>b</sup>

2) When the test duration is 1 minute, the output voltage is to be increased from zero at a uniform rate so as to arrive at the specified potential in 5 seconds. The output voltage is to be maintained within the specified range, by manual or automatic means, throughout the 1 minute duration of the test or until there is an indication of noncompliance.

c) When the test equipment is adjusted to produce the specified voltage, and a resistance of 120,000 ohms is connected across the output, the test equipment is to indicate noncompliance within 0.5 second. A resistance of more than 120,000 ohms is to be used to produce an indication of noncompliance when the manufacturer elects to use a tester having higher sensitivity.

<sup>b</sup> The details for a test device, which is to be constructed to perform the resistance reductions, are in R.21.8.

### R.21.3 DC production-line test

When adjusted for production-line testing, a dc tester is to provide a means for indicating noncompliance. For the purpose of these requirements, noncompliance is defined as:

a) An abrupt decrease or nonlinear advance of voltage as the test voltage is increased, or similarly.

b) An abrupt increase in current.

### R.21.4 Polarization verification

Electrical-continuity is to be verified as a routine production-line procedure between the grounded supply-circuit conductor of the attachment plug (wide blade of a two-wire plug) and externally ACCESSIBLE PARTS of the apparatus that are intended to be connected in the earthed supply-circuit, such as the identified contact (wide slot) of a parallel-slot receptacle, the screw shell of an Edison-base lampholder or plug fuseholder, and the accessible contact of an exterior fuseholder. The continuity is to be verified either visually or through the use of an electrical test. See R.21.6.

### R.21.5 Continuity of earthing connection

When an apparatus is provided with a earthing-type attachment plug, electrical continuity between the earthing blade of the attachment plug and all conductive parts that are accessible (only those parts that result in electric shock) shall be maintained and verified as a routine production-line test. The continuity is to be determined either visually or through the use of an electrical test. See R.21.6.

**R.21.6** Electrical indicating device

Any indicating device (such as an ohmmeter or a low-voltage battery-and-buzzer combination) is capable of being used in the tests described in R.21.4 and R.21.5.

**R.21.7** X-Radiation measurement verification

Periodic production line sampling measurements of X-Radiation shall be conducted on apparatus employing cathode-ray-tubes (CRTs) in accordance with Federal Regulations 21CFR 1002.10 and 1002.12. The results of the recorded measurements shall be made available for audit. Test records shall include corrective action for any nonconforming results.

**R.21.8** Variable resistance load for the voltage output check described in R.21.2.**R.21.8.1** Purpose

R.21.8.1.1 Figure R.1 provides an example of a variable resistance load which is capable of being simply constructed to accomplish the varying resistance loading [in 25% steps as outlined in R.21.2(b)(1)].

**R.21.8.2** General

R.21.8.2.1 The details of a step-type variable resistance load using commonly available resistors are shown in figure R.1 and table R2.

**Table R2**  
**Power consumed in watts**

<u>Resistor in ohms</u>	<u>Applied voltage</u>			
	<u>1200 V</u>	<u>1500 V</u>	<u>2700 V</u>	<u>4500 V</u>
<u>120 K</u>	<u>12</u>	<u>19</u>	<u>61</u>	<u>169</u>
<u>159 K</u>	<u>9.1</u>	<u>14</u>	<u>46</u>	<u>127</u>
<u>210 K</u>	<u>6.9</u>	<u>11</u>	<u>35</u>	<u>96</u>
<u>648 K</u>	<u>2.2</u>	<u>3.5</u>	<u>11</u>	<u>31</u>
<u>1500 K</u>	<u>0.96</u>	<u>1.5</u>	<u>4.9</u>	<u>14</u>

NOTE – Represents the maximum watts consumed by the resistor when used as shown in figure R.1 at the voltages indicated.



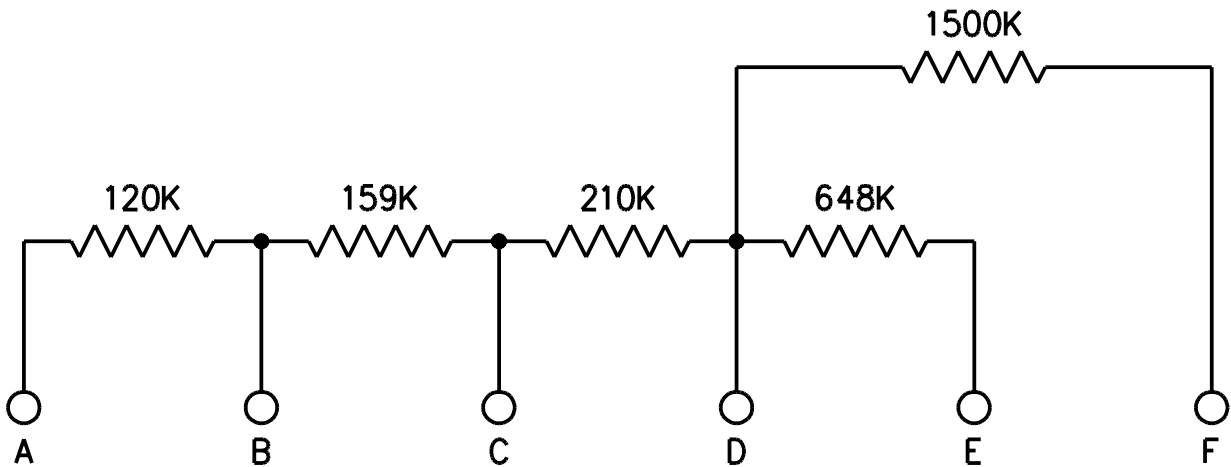

S2292

<u>Terminals</u>	<u>Resistance (ohms)</u>	<u>Current (mA) at 1200 V</u>
<u>AB</u>	<u>120K</u>	<u>10.00</u>
<u>BC</u>	<u>159K</u>	<u>7.55</u>
<u>CD</u>	<u>210K</u>	<u>5.71</u>
<u>AC</u>	<u>279K</u>	<u>4.30</u>
<u>BD</u>	<u>369K</u>	<u>3.25</u>
<u>AD</u>	<u>489K</u>	<u>2.45</u>
<u>DE</u>	<u>648K</u>	<u>1.85</u>
<u>CE</u>	<u>858K</u>	<u>1.40</u>
<u>AE</u>	<u>1.137K</u>	<u>1.05</u>
<u>DF</u>	<u>1.500K</u>	<u>0.80</u>
<u>AF</u>	<u>1.989K</u>	<u>0.60</u>
<u>EF</u>	<u>2.148</u>	<u>0.56</u>

**Figure R.1**  
**Details for a typical step-type variable-resistance-load**

No Text on This Page

**Annex S DC**  
**(normative)**  
**Standards for components**

Standards under which components of the apparatus covered by this standard are evaluated include the following:

Title of Standard – UL Standard Designation

---

Attachment Plugs and Receptacles – UL 498

Batteries, Lithium – UL 1642

Communication Circuit Accessories – UL 1863

Flexible Cord and Fixture Wire – UL 62

Fluorescent-Lamp Ballasts – UL 935

Fuseholders – UL 512

High-Intensity-Discharge Lamp Ballasts – UL 1029

Information Technology Equipment – UL 1950, Third Edition

Lampholders, Edison-Base – UL 496

Lampholders, Starters, and Starter Holders for Fluorescent Lamps – UL 542

Signaling and Nurse Call Equipment, Hospital – UL 1069

Switches, Special-Use – UL 1054

Time-Indicating and -Recording Appliances – UL 863

No Text on This Page

**Superseded requirements for  
the Standard for  
Audio/Video and Musical Instrument Apparatus for Household, Commercial, and Similar General  
Use,**

**UL 6500, Second Edition**

The requirements shown are the current requirements that have been superseded by requirements in revisions issued for this Standard. To retain the current requirements, do not discard the following requirements until the future effective dates are reached.

**19 DU Stability and mechanical hazards**

Apparatus having a mass exceeding 18 kg shall have adequate stability.

In addition, the stability shall be ensured when legs or stands supplied by the manufacturer are fitted.

*Compliance is checked by the tests of 19.1, and 19.2 and 19.2.1.*

*During the tests, the apparatus shall not overbalance.*

**19.1 DU** *The apparatus is placed in its intended position of use on a plane, inclined at an angle at 10° to the horizontal. All doors, drawers, casters, wheels, adjustable feet (levelers) and other appurtenances of the apparatus are positioned in any combination that results in the least stability. Legs and other means shall be blocked to keep the apparatus from sliding. It is and then rotated slowly through an angle of 360° about its normal vertical axis.*

*If, however, the apparatus is such that, were it to be tilted through an angle of 10° when standing on a horizontal plane, a part of it not normally in contact with the supporting surface would touch the horizontal plane, the apparatus is placed on a horizontal support and tilted in the most unfavourable direction through an angle of 10°.*

NOTE – The test on the horizontal support may be necessary, for example, for apparatus provided with small feet, castors or the like.

**19.2.1 DU** *The apparatus is placed on a non-skid surface with lids, flaps, drawers, doors, casters, wheels, adjustable feet (levelers) and other appurtenances in the most unfavorable position.*

*A force of 100 N or 20% of the weight of the apparatus, whichever is less, is directed horizontally in such a way as to produce the maximum overturning moment to any point on the apparatus greater than 100 cm from the floor, provided that the distance of that point to the floor does not exceed 150 cm*

*For an apparatus having a mass of 25 kg or more, a force of 90 N or 13% of the weight of the apparatus, whichever is less, is directed horizontally in such a way as to produce the maximum overturning moment at any point on the apparatus, provided that the distance of that point to the floor does not exceed 150 cm.*

### R.21.1 Production-line dielectric voltage-withstand test

Each apparatus shall withstand as a routine production-line test the application of a potential not less than 1080 V, 50 or 60 Hz, or 1530-V direct potential between parts involving the risk of electric shock and accessible conductive parts for a period of 1 (plus 1, minus 0) second, without an indication of noncompliance. For a definition of noncompliance, see R.21.2(c), or see R.21.3.

The test is not required to be made on speakers and similar components mounted in cabinets made of wood or other nonconductive material when the components are not touched or handled in the use of the apparatus and when their mounting screws, or the equivalent, are not exposed on the exterior of the cabinet.

At the manufacturer's option, the 50- or 60-Hz test is to be conducted at a potential of 5/6 the specified voltage with the duration of application increased to 1 minute.

The manufacturer shall determine by a routine production-line test that each product that is marked with the DOUBLE INSULATION symbol withstands for 1 second without breakdown the application of the test potential indicated in table R1.

To reduce the risk of damage to the apparatus, dielectric-withstand potentials exceeding 2000 V, 50 or 60 Hz or 2828 V dc for more than 4 seconds are not to be used. When it is specified to use higher potentials or longer durations, or both, an investigation as described in (a) below is to be conducted to determine that the insulation in the apparatus is not damaged. See (b) below for the performance test dielectric voltage-withstand test which is required when the production-line dielectric voltage-withstand test potential either exceeds 1300 V, 50 or 60 Hz, or 1840 V dc, or is applied for more than 2 seconds.

a) When the production-line dielectric voltage-withstand test potential exceeds 2000 V, 50 or 60 Hz, or 2828 V dc, or a time duration of more than 4 seconds, three samples of the apparatus are to be subjected to the continuous application of the voltage potential that the manufacturer intends to use on the production line for a duration that is 100 times the factory-test time. There shall be no breakdown of insulation or spacings in the apparatus that results in a risk of fire or electric shock.

b) When the production-line dielectric voltage-withstand test potential exceeds 1300 V, 50 or 60 Hz, or 1840 V dc, or a time duration of more than 2 seconds, the insulation and spacings of an apparatus shall withstand without breakdown for 1 minute a 2875-V, 60-Hz potential applied between parts involving a risk of electric shock and accessible conductive parts.

The test is to be conducted when the apparatus is complete and ready for packing, or when it is complete except for parts such as snap covers or friction-fit knobs that interfere with the performance of the test. For the test, the apparatus is capable of being in the heated or unheated condition.

The test equipment is to include:

a) A means for indicating the test voltage that is being applied to the apparatus being tested. This is to be accomplished by sensing the voltage at the test leads, or by an equivalent means.

*b) A means for effectively indicating noncompliance. The indication is to be auditory when it is capable of being readily heard above the background noise level, visual when it commands the attention of the operator, or a device that automatically rejects noncompliant apparatus. When the indication of noncompliance is auditory or visual, the indication is to remain active and conspicuous until the test equipment is reset manually.*

*There is to be no transient voltage applied to the apparatus being tested that results in an instantaneous voltage to the apparatus exceeding 120% of the peak value of the test voltage that the manufacturer specifies for this test. This requirement applies for the entire duration of the test, including the time that the voltage is first applied to the apparatus and the time that the voltage is removed from the apparatus.*

*The control of the applied voltage specified in these requirements, whether manual or automatic, is to be maintained under conditions of varying line voltage. Higher test potentials are to be used only when the higher dielectric stress will not adversely affect the insulating systems of the apparatus.*

**Table R1**  
**Production line dielectric voltage-withstand test potential for products marked with the DOUBLE INSULATION symbol**

<u>Points between which potential is to be applied</u>	<u>Test potential in volts</u>	
	<u>RMS</u>	<u>Peak</u>
<u>1. LIVE PARTS and dead metal parts insulated from one another by BASIC INSULATION</u>	<u>1000</u>	<u>1414</u>
<u>2. Inaccessible dead metal parts and accessible dead metal parts insulated from one another by supplementary (protecting) insulation</u>	<u>1500</u>	<u>2122</u>
<u>3. LIVE PARTS and accessible dead metal parts</u>	<u>2500</u>	<u>3535</u>
<p><u>NOTES</u></p> <p><u>1 When required because of the inaccessibility of parts, tests in accordance with items 1 and 2 are to be conducted on subassemblies of the equipment, and, in this case, the test indicated in item 3 is to be conducted. When the tests in accordance with items 1 and 2 are conducted on the completely assembled equipment, the tests indicated in item 3 are to be omitted when there is NO REINFORCED INSULATION.</u></p> <p><u>2 Those parts of the test described in items 2 and 3 that include application of metal foil to outer enclosures of insulation material are not required when the manufacturer has the following quality-control program. This program is to determine that the insulating material in question is free from cracks and metal inclusions, and that it has the physical and electrical strength required for the application. To determine that the material is free of cracks or metal inclusions, a 100 percent visual inspection is required. Periodic physical-property tests on molded parts shall also be conducted.</u></p>		

No Text on This Page