

# VERSATILE LED DISPLAY

■ PRIYANK MUDGAL

This circuit uses an erasable programmable read-only memory (EPROM) to display various light patterns on LEDs. Since bicolour LEDs (comprising green and red LEDs) have been used, display is possible in

three colours (green, red and amber). The circuit is powered by 5V DC. IC 555 (IC1) is wired as an astable multivibrator, whose oscillation frequency can be varied using preset VR1. The output of IC1 clocks 12-stage binary counter IC CD4040 (IC2), which in turn, provides address data to

EPROM IC 2716 (IC3). IC3 contains the code (see Table I) for the display.

The high logic at any data pin causes the corresponding LED to glow. When the data at address location 00H is addressed, the red LED of LED1 glows. The data byte 44H at address location 09H causes both the green and red LEDs of LED2 to glow (refer the table).

The binary outputs of IC2 comprising Q0, Q1, Q2, Q5, Q6, Q7, Q8 and Q9 have been connected to address pins A0 through A7 of EPROM IC3 (2716). Q3 and Q4 outputs of IC2 have not been used. This causes each display pattern to be repeated eight times before the next pattern is displayed. You can adjust the number of times a display pattern repeats by changing the output lines of IC2 connected to the EPROM's address pins A0 through A7.

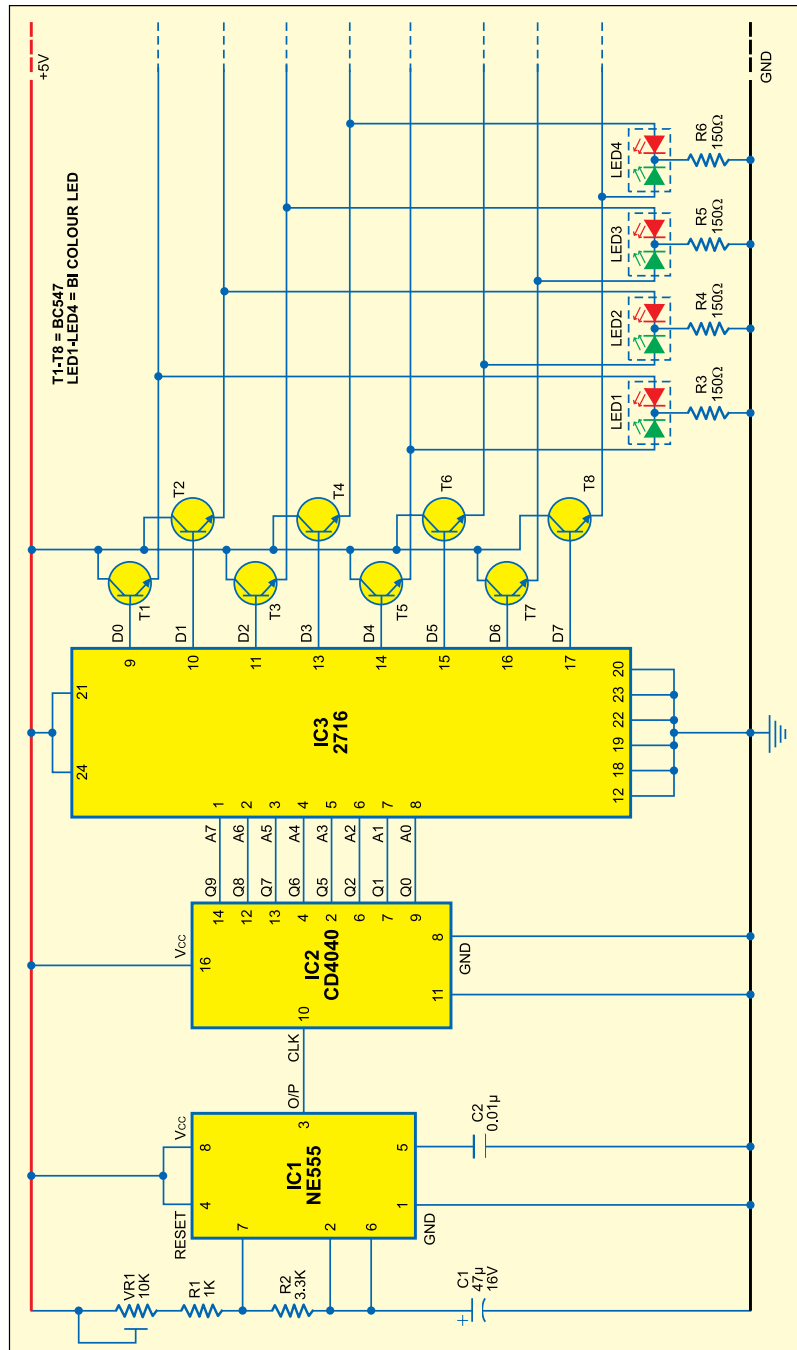

**Binary Code for EPROM**

Address	Data	Address	Data
00	01	20	F0
01	02	21	F0
02	04	22	F0
03	08	23	F0
04	10	24	0F
05	20	25	0F
06	40	26	0F
07	80	27	0F
08	88	28	FF
09	44	29	FF
0A	22	2A	FF
0B	11	2B	FF
0C	F8	2C	F0
0D	F4	2D	0F
0E	F2	2E	FF
0F	F1	2F	F0
10	8F	30	0F
11	4F	31	87
12	2F	32	C3
13	1F	33	E1
14	87	34	F0
15	4B	35	E1
16	2D	36	C3
17	1E	37	87
18	78	38	F0
19	B4	39	78
1A	D2	3A	3C
1B	E1	3B	1E
1C	84	3C	0F
1D	42	3D	1E
1E	21	3E	3C
1F	18	3F	78

The circuit uses a total of four bicolour LEDs. However, more LEDs in pairs of four can be added in the dotted lines (see the figure). Suppose you want to connect four more bicolour LEDs (LED5 through LED8, not

shown in the figure). For this, you'll have to connect them in parallel to LED1 through LED4, respectively. The speed of the display can be changed by varying preset VR1, which changes the clock frequency.

You can also create other display patterns by coding the EPROM accordingly. Note that the code should be burnt into the EPROM (by using a programmer kit) before it is inserted into the circuit. ●

---