

An AC Dimmer for Use with the Stamp

The Document contains directions for converting a commercial 120VAC dimmer for use with the stamp's PV output.

IDEA OF OPERATION

The basic idea of the circuit is to replace the variable resistor that is connected to the knob of a dimmer with an optoisolator. The optoisolator is connected to an operational amplifier that interfaces with the stamp. Users of this circuit should read and be familiar with the operation of the stamp's PWM function. This document assumes that you have read and understood the PWM section of the stamp manual. It is also assumed that you have some experience wiring AC. As it is likely you do not have experience with AC, please find someone who has. AC is dangerous and it can kill you.

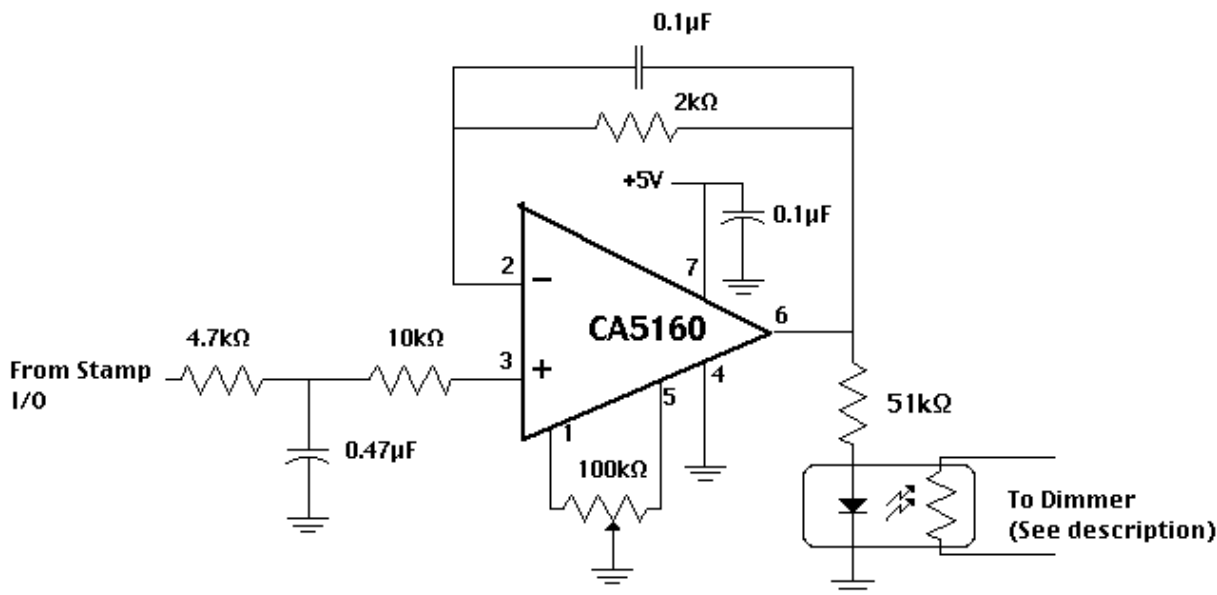

The circuit is simple, The op-amp provides current amplification allowing the optoisolator to sink current without discharging the 4.7μF capacitor. The 51kΩ resistor provides the right current through the optoisolator to provide the right resistance on the output of the optoisolator.

Parts

Dimmer: Lutron Rotary Dimmer, part # D-600RH-WH available for Home Depot.

Op-amp: Manufactured by Harris, available from [Newark Electronics](#), Newark Part # 06F2202

Optoisolator: Manufactured by EG&G Optoelectronics, EG&G part # VTL5C8, available from [Newark Electronics](#), Newark Part # 97F1140

Directions For construction

Carefully remove back plastic cover from the dimmer. There should be two rivets holding it on. I recommend using a drill to remove the head of the rivet.

On the back of the plate you will find a cylinder about an inch in diameter and half an inch tall. Around the top of the cylinder are a bunch of components. On the flat side of the cylinder there are two leads, These leads are the on-off switch of the dimmer. On one side of the rounded part of the cylinder there are three solder lugs, of which one connects to wires or other components. Remove the component from the center one, this should just be just one resistor. Place the end of the optoisolator labeled 'cell' between the center lug and the resistor you just removed.

Build the circuit on a small piece of perf-board, use wires to connect the optoisolator to the perf-board. Remember that the input of the optoisolator is a LED and the polarity is important. The polarity should be marked on the case of the optoisolator.

There should be three wires coming out of the dimmer, one green and two black. The green wire should be connected to ground, the bottom, round prong on a plug. The two black wires should be connected in series with the load.

