

Keyboard/display sound converter

K. G. Reid

This circuit can be used in several modes: It can provide quantized feedback (a distinct improvement over the normal single 'bleep') from the key actions made on a calculator-type keyboard: It can be used to give a 'sound' translation of a digital display, or completely replace the display when sound would be a better communication medium.

The keyboard or display information (a maximum of 16 bits with one 16-line 74150 multiplexer) is translated into a series of 16 high or low frequency tone pulses, corresponding to the 'high' or 'low' logic state of the 16 bits.

The circuit illustrated was used in conjunction with a digital multimeter, requiring three 4-bit words for the digits and three additional bits for over-range, negative and decimal point. Thus, 15 lines only were required, the 16th being used for resetting.

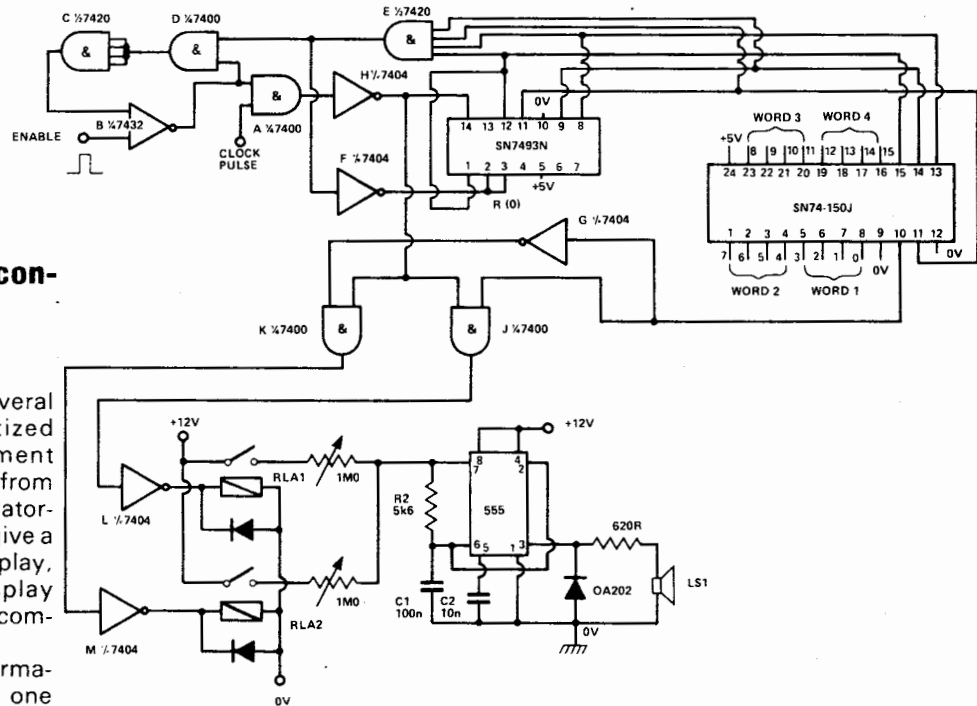

The 15 bits are latched on to the inputs of the 74150 multiplexer. Presentation of the enable pulse results in a logic '1' appearing at the output of gate B, allowing clock pulses to pass via gates A and H to the 7493 counter. Gates B, E, D and C form a latch which remains 'set' until all 15 bits have been sampled. As each bit is sampled, the inverse state appears at the multiplexer output, opening gate

J or K and thus operating one of the two reed relays. As a count of 1111 appears from the counter, the output of F drops low, resetting the latch and counter. The operation of either relay results in a tone appearing at the loudspeaker (or earpiece), the tone frequencies being set (1.2 kHz maximum) by the 1 megohm pots. The tone pulse length is governed by the clock rate.