

RS232 Transceivers for Hand Held Computers Withstand 10kV ESD – Design Note 64

Sean Gold

Battery-powered computers and instrumentation are often subjected to severe electrical stress which imposes some stringent demands on serial communication interfaces. As always, operating from a battery mandates minimal power consumption. Transceivers must also tolerate repetitive Electrostatic Discharge (ESD) pulses because cable connections frequently come in contact with humans and other charged bodies.

Linear Technology's LT1237 addresses the above requirements. The LT1237 is a complete RS232 port, with three drivers, five receivers and a regulated charge pump. Supply current is typically 6mA, but the device can be shut down with two separate logic controls. The driver disable pin shuts off the charge pump and the drivers—leaving all receivers active, $I_{SUPPLY} = 4mA$. The ON/OFF pin shuts down all circuitry except for one micropower receiver, $I_{SUPPLY} = 60\mu A$. The active receiver is useful for detecting start-up signals. The LT1237 operates up to 120kbaud and is fully compliant with all RS232 specifications. Connections to the RS232 cable are protected with internal ESD structures that can withstand repetitive $\pm 10kV$ human body model ESD pulses.

Figure 1 shows a typical application circuit. The LT1237's flow through pinout and its ability to use small surface mount capacitors, helps reduce the interface's overall footprint.

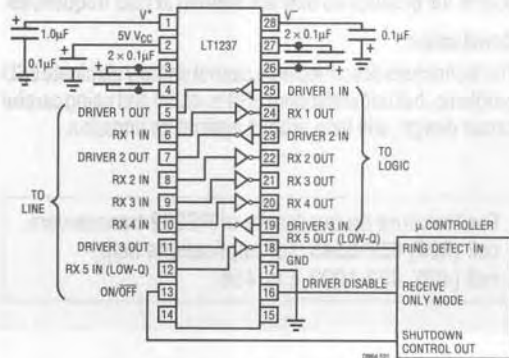

Figure 1. LT1237 Application Circuit

Interfacing with 3V Logic

Hand held computers are rapidly moving to 3V logic to save power. Yet higher voltage buses are still utilized elsewhere in the system for display driving and other functions. The LT1330 is functionally equivalent to the LT1237 but operates from 5V with a separate logic supply to interface directly with 3V logic. (Figure 2)

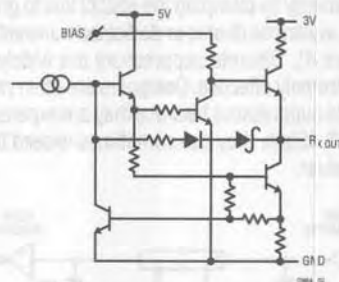

Figure 2. Receiver Output Stages in the LT1330 are Biased From a Separate Logic Supply to Easily Interface with 3V Systems

ESD Protection Techniques

Even though the I/O pins on the LT1237 and LT1330 are protected, a basic understanding of electrostatic discharge, its causes and its remedies, is helpful when designing with these circuits.

ESD generated by triboelectric charging of the human body is often the most troublesome problem for portable computers.¹ Energy imparted during a discharge is usually in the form of a rapidly rising high voltage pulse with a slow exponential tail. ESD pulses can be modeled with the switching circuit shown in Figure 3. ESD contributes frequency components well into the GHz range. At such frequencies, nearby cables and PC board traces look like receiving antennas for ESD noise.

1. Triboelectricity is the charge created as a result of friction between bodies.

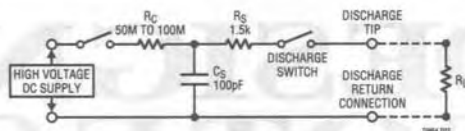

Figure 3. Human Body Circuit Model for ESD Pulses

Circuit damage from ESD can occur as a result of three effects: (1) High current heating, which destroys junctions or metallization. (2) Intense electromagnetic fields, which break down junctions or thin oxides. (3) Radiated noise, which drives the circuit into invalid or locked up states.

Any action which eliminates the charge generator, circumvents charge transfer, or enhances the circuit's ability to absorb energy, will increase a circuit's tolerance of ESD. Eliminating the ubiquitous charge generators and disrupting charge transfer are difficult tasks because they demand strict control of the circuit's operating environment. A more practical approach is to limit ESD entry points by shielding the circuit's enclosure and covering the RS232 port's connector when it is not in use.

Another practical remedy is to increase a transceiver's ability to absorb energy by clamping the RS232 line to ground with fast acting avalanche diodes or dedicated transient suppressors (Figure 4). Discrete suppressors are widely available and are extremely effective. Designers are often reluctant to use discrete suppressors because they are expensive. Costing up to \$0.40/pin, they can sometimes exceed the cost of the transceiver.

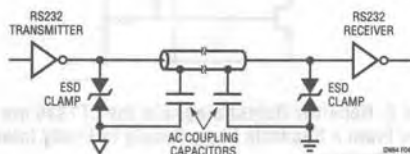

Figure 4. Older Interface Designs Used External ESD Clamps

The LT1237 and LT1330 incorporate the clamps for diverting ESD energy on chip. These active structures quickly respond to positive or negative signals at threshold voltages higher than RS232 signals, yet below destructive levels for the device. The path of high current flow is through large pn junctions which increases the capacity to absorb energy.

When a discharge occurs, the resulting current flow is insignificant when the transceiver is turned off or powered down. When operating, the resulting current may bias internal circuitry and lock up the circuit. Observations have shown these nondestructive errors to be highly dependent upon the logical state of the transceiver. Cycling the power clears the circuit.

When very high levels of ESD protection are required, an external LC filter (Figure 5) can be used to drop ESD energy into a range that can be safely dissipated within the transceiver.

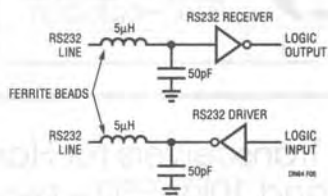

Figure 5. External LC Filters Provide Protection From Very High Levels of ESD Yet Cost Less Than Discrete Suppressors

PC Board Layout

Energy shunted through an ESD clamp can still cause problems if the impedance of the return path is large enough to create a sizable voltage drop. Such voltage drops may damage unprotected components that share the common return line. Including a low inductance ground plane in the PC board is therefore essential for good ESD protection. For the LT1237 and LT1330, the AC path to ground through V⁻ must also be low impedance. Adding a few hundred picofarads of low ESR capacitance in parallel with the primary storage capacitor provides a good AC ground.

When using discrete transient suppressors or filters, place components as close as possible to the connector with short paths to the return plane. Make the spacing between the circuit board traces as wide as possible. ESD pulses can easily arc from one trace to another when the spacing between traces is narrow. Arcing occurs slowly compared with ESD rise time, so air spark gaps alone will not protect circuitry from ESD. Dedicated spark gaps are effective for limiting ESD energy when used with additional suppression devices.

Do not float the cable shield with respect to local ground. Designers may feel inclined to do this to avoid circulating current due to differences in ground potential. Instead, AC couple the grounds so they are shorted at ESD frequencies.

Conclusion

The techniques described here cannot entirely eliminate ESD problems, but understanding ESD's nature and using careful circuit design, will help protect against its intrusion.

For literature on our family of RS232 transceivers, call (800) 637-5545. For applications help, call (408) 432-1900, Ext. 456