

Driving a Low Noise, Low Distortion 18-Bit, 1.6MSPS ADC

Design Note 494

Guy Hoover

Introduction

The LTC®2379-18 is an 18-bit, 1.6MSPS SAR ADC with an extremely high SNR of 101dB and THD of -120dB. It also features a unique digital-gain compression function, which eliminates the need for a negative supply in the ADC driver circuit.

Designing a driver circuit to get the best possible performance from the LTC2379-18 is not difficult. The two circuits presented here demonstrate differential and single-ended solutions using dual and single supplies. Note that the components used here have been carefully chosen with the ADC's accuracy and acquisition time requirements in mind, so any modifications should be thoroughly tested.

Fully Differential Driver

The circuit of Figure 1 converts a fully differential $\pm 5V$ signal to a fully differential 0V to 5V signal—the normal input range for the LTC2379-18. This circuit is useful for sensors that produce a fully differential output.

Filter networks R3, R5, C6 and R4, R6, C7 limit the input bandwidth to approximately 100kHz. Matching on these networks is important to achieve the lowest distortion, as a mismatch in delay results in the development of a common mode signal. The filter network comprising R1, R2, C1, C2 and C3 minimizes the noise contribution of

the LT®6203 and minimizes disturbances reflected into the LT6203 from sampling transients. The 32k point FFT in Figure 2 shows the performance of the LTC2379-18 in the circuit of Figure 1.

Single Supply Driver

The circuit of Figure 3 uses the digital gain compression feature of the LTC2379-18, which defines the ADC full-scale input swing to be 10% to 90% of the reference voltage. This means that for a 5V reference the full-scale swing is

LT, LTC, LTM, Linear Technology and the Linear logo are registered trademarks of Linear Technology Corporation. All other trademarks are the property of their respective owners.

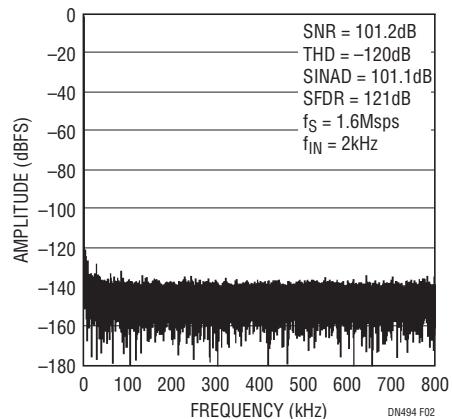

Figure 2. 32k Point FFT Using the Circuit of Figure 1

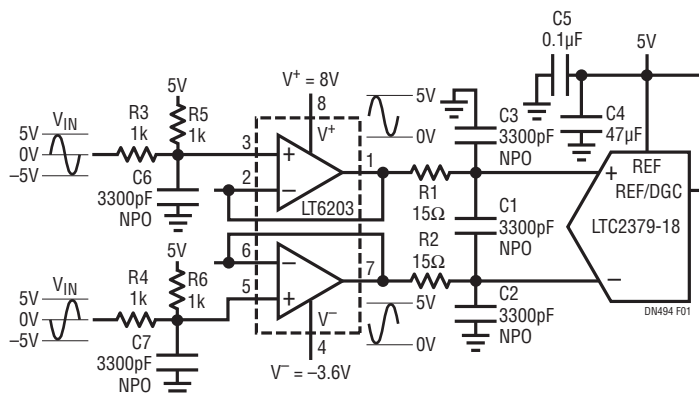

Figure 1. An LTC2379-18 Fully Differential $\pm 5V$ Driver Using the LT®6203

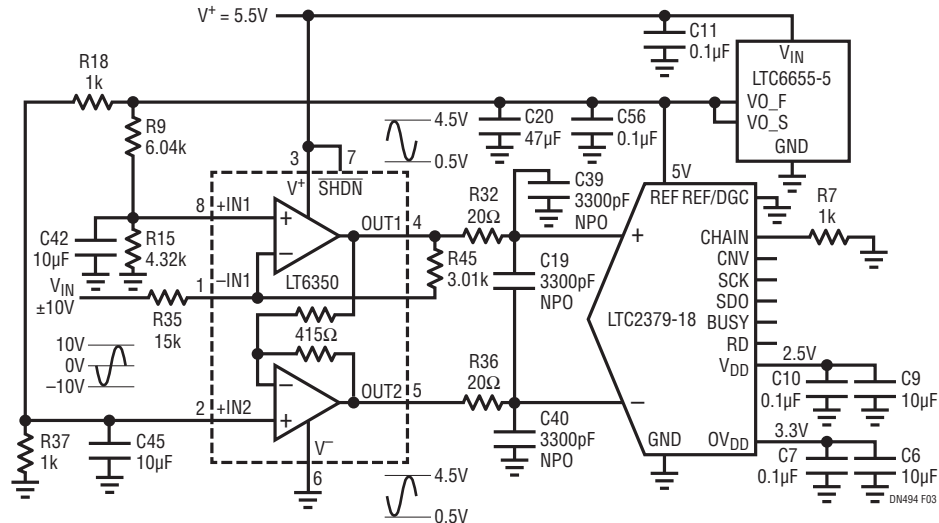

Figure 3. LTC2379-18 Single Supply, ±10V Single-Ended Driver Using the LT6350

0.5V to 4.5V. This is sufficient headroom for the LT6350, so a negative supply is not needed. This not only saves the cost and complexity of providing a negative supply, it also reduces the overall power consumption of the ADC driver portion of the circuit by a factor of two.

By using the LTC6655-5 precision low noise reference, which only requires a supply 0.5V above its output, the entire circuit can be operated from a single 5.5V supply.

This circuit accepts a ±10V single-ended input voltage and converts it to a 0.5V to 4.5V fully differential signal. SNR for this circuit is 99dB due to the reduced input swing and THD is still a very good -95dB.

Layout Considerations

When dealing with a high speed 18-bit ADC, PC board layout must be carefully considered. Always use a ground plane. Keep traces as short as possible. Keep bypass capacitors as close to the supply pins as possible. Each bypass capacitor should have its own low impedance return to ground. The analog input traces should be screened by ground. The layout involving the ADC analog inputs should be as symmetrical as possible so that parasitic elements cancel each other out. The output of the reference and the REF pin bypass capacitors should be as close to the REF pin as possible.

Figure 4 shows a sample layout for the LTC2379-18. Figure 4 is a composite of the top, ground, bottom and silk screen layers. Component numbers used in the circuit

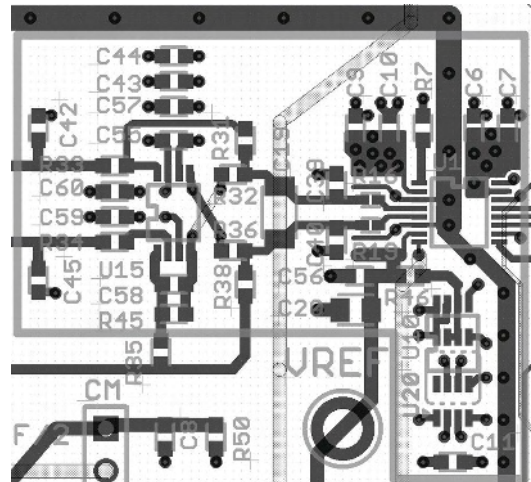

Figure 4. LTC2379-18 Sample Layout

of Figure 3 refer to layout of Figure 4. See the DC1783A demo board manual available at www.linear.com for a complete LTC2379-18 layout example.

Conclusion

Driving the LTC2379-18 is not difficult. Using the simple circuits described here, the LTC2379-18 can be driven over a variety of input voltage ranges with fully differential or single-ended inputs. With its unique digital-gain compression function, the LTC2379-18 can be driven with a single supply, which saves power while reducing cost and complexity.

Data Sheet Download

www.linear.com/2379

For applications help,
call (408) 432-1900