

Simple circuit provides power sequencing

John Betten, Texas Instruments, Dallas, TX

ASICs, FPGAs, AND DSPs can require multiple supply voltages with restrictions on their start-up sequencing. Often, I/O voltages, which usually have the highest voltage, must come up first, followed by all other voltage rails in a high-to-low order, with the core voltage last. This scenario may also require that one supply rail not exceed another by more than a diode drop; otherwise, excessive current may flow backward from the I/O voltage through the IC into a lower voltage, possibly damaging the expensive IC. Often, you can control this sequence by placing external diodes between successive voltage rails to clamp a higher voltage to within a diode drop of a lower voltage, thus preventing possible latch-up in the IC. The diode conducts only when a lower voltage rises above a higher one at turn-on, but not if a higher voltage were to increase above any lower voltage, because the diode is reverse-biased. A preferred method would be to use the power-supply controller to precisely control the start-up-voltage sequencing of the power-supply rails. Fig-

ure 1 shows a simple op-amp circuit that integrates a dual switching power supply to provide simultaneous output-voltage sequencing.

In this power-sequencing circuit, three output voltages sequence at start-up, during which each output voltage tracks the next-higher voltage rail until it reaches its fixed regulation voltage. Assume that a 3.3V "master"-I/O voltage (not shown) powers up normally. The controller for this voltage uses its soft-start function to provide a smooth linear ramping of its voltage. The TPS5120 dual switching regulator generates two additional voltages, 2.5 and 1.8V. In most standard switching-regulator circuits, the bottom sides of R_4 and R_{10} would be grounded, thus fixing the output-voltage setpoints. In this circuit, the output of an amplifier controls the voltage at the bottom of each of these resistors. An amplifier output voltage of zero sets the output voltage to its predetermined fixed voltage, but any voltage greater than zero forces the output voltage to be lower than its setpoint.

The amplifiers are in an inverting con-

figuration with the next-higher output voltage as its input or "sense" voltage. Thus, at power-on, when the 3.3V output is 0V, amplifier IC₁'s output voltage is high, also forcing the TPS5120 controller to regulate its output voltage to 0V. The output voltage of amplifier IC₃ is also high, because the 2.5V output, which is also 0V, controls input voltage. As the 3.3V output rises linearly, the amplifier's output voltage decreases linearly to 0V. The 2.5V output voltage thus increases from 0V to its maximum setpoint of 2.5V. The 1.8V output voltage tracks the 2.5V output in a similar manner. Set the amplifier's component values such that when the sensing voltage, such as the 3.3V, reaches the tracking-voltage level—here, 2.5V—the amplifier's output voltage just attains 0V. Therefore, increases in the sense voltage higher than 2.5V cannot further raise the tracking output voltage, because the amplifier's output voltage has already saturated to ground level.

Simultaneous tracking requires several important design criteria. The amplifier's feedback ratio, R_5 - R_6 , must be equal

Figure 1

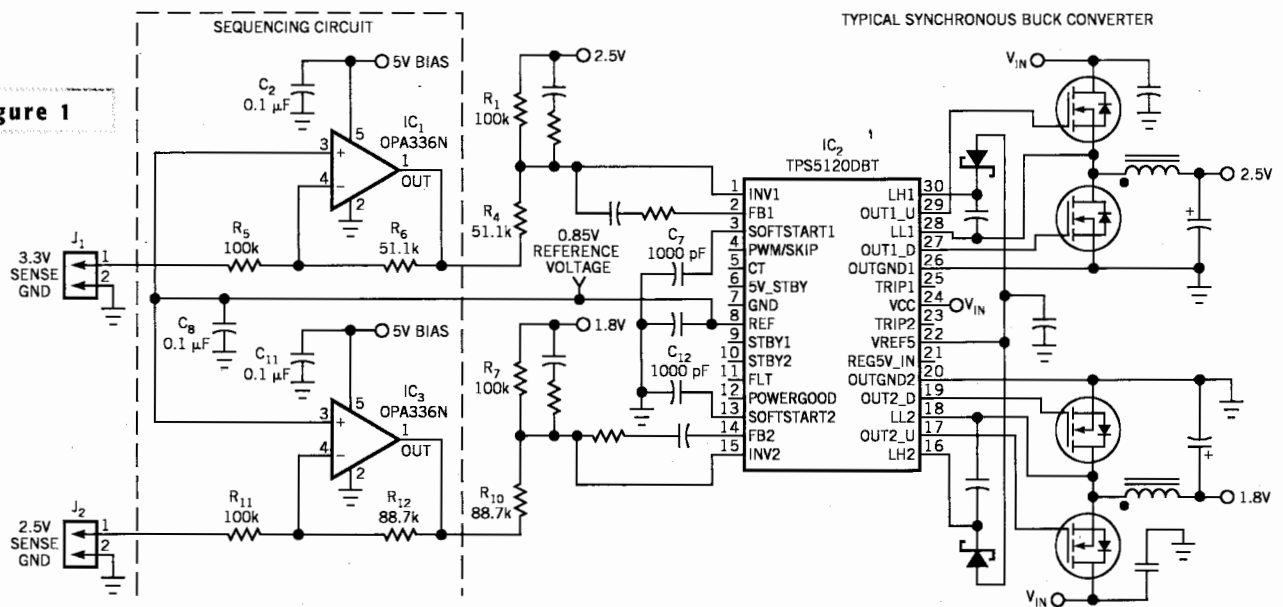

An amplifier circuit forces the converter's output voltages to track during start-up.

to the feedback-resistor divider ratio set by R_1 and R_2 . In addition, you must use the TPS5120 controller's reference voltage, 0.85V in this example, as an input to the amplifier's noninverting terminal. Any reference-voltage value other than this one forces the tracking-voltage output to a voltage different from the sense voltage. The amplifier you select should have a low input-offset voltage and be capable of an output voltage at least as great as the controller's reference voltage.

A rail-to-rail amplifier works well in this application. Individual amplifiers to allow localized component placement, avoiding routing near any noise sources. This design uses an additional decoupling capacitor near the

amplifier's noninverting input for the reference voltage. It uses a small, soft-start capacitor value for the TPS5120 controller so that the controller was in-

herently faster at start-up than the 3.3V sense voltage. A large soft-start capacitor value does not allow for fast tracking on the outputs. Too small a value may cause output-voltage overshoot when you initialize power. **Figure 2** shows the start-up voltages for three synchronous buck converters. The 3.3V acts as a master, and 2.5 and 1.8V track their respective higher voltages. You can set the sense voltage for the 1.8V output to track the 3.3V output rather than the 2.5V with equally good linear tracking during start-up. You can add this sequencing circuit to any power-supply controller that provides access to its reference voltage, soft-start capacitors, and output-voltage resistor-divider network. □

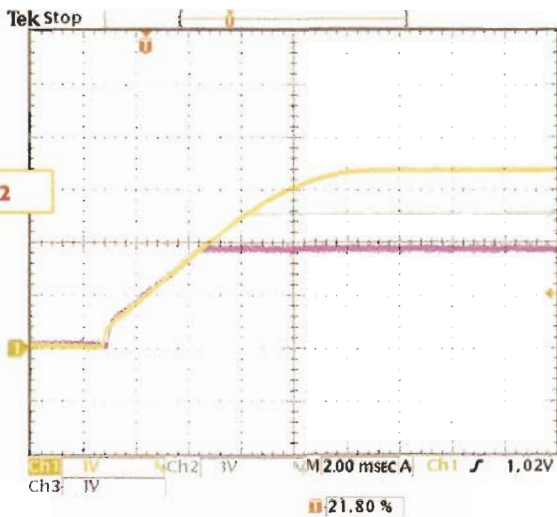
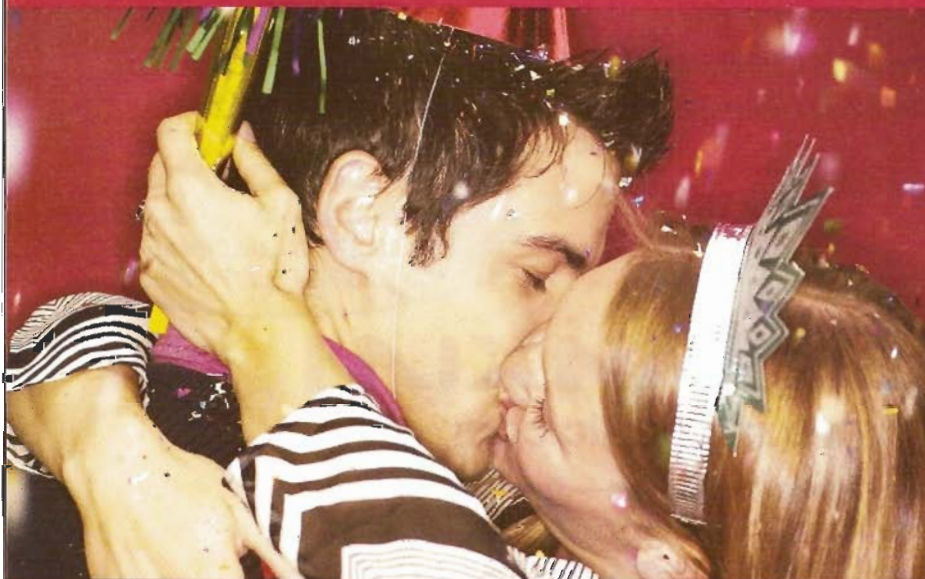

Figure 2

The 2.5 and 1.8V outputs track the 3.3V output at start-up.

Because Some Events Require Perfect Timing



Introducing Intersil's New Low Cost Real Time Clock that Combines High Accuracy with Ultra-Low Power Consumption.

Consuming only 500nA of current when running off of a battery or SuperCap, Intersil's new ISL1208 Real Time Clock is a marriage of high precision, low power and competitive pricing for today's demanding systems.

In addition to accurate clock and calendar functions, the ISL1208 device integrates crystal and timing compensation, flexible alarm, programmable clock output, power fail detection and intelligent battery backup switching into one space-saving package.

The ISL1208 is available in either 8-Lead MSOP or SOIC for off-the-shelf pricing of \$1.10 in 1K units.



Get more technical info on Intersil's complete portfolio of High Performance Analog Solutions at www.intersil.com/info
 Samples at www.intersil.com/xicorsamples More info at www.intersil.com/ISL1208

©2004 Intersil Americas Inc. All rights reserved. The following are trademarks of Intersil Americas Inc.: Intersil, Intersil logo, "I" and Design. Xicor is a trademark of Intersil Corporation or one of its subsidiaries.

Amplifiers | Converters | DataComm | DCPs/DCCs | Display | Interface | Power Management | Switch/MUX | Timing | Video



Enter 56 at www.edn.com/info