

Analog switch converts 555 timer into pulse-width modulator

Jordan Dimitrov, Tradeport Electronics, Vaughan, ON, Canada

This Design Idea describes a new approach to producing a variable-duty-cycle waveform from a 555-based free-running oscillator. The circuit's wide modulation range, highly linear control over a wide range of duty-cycle values, and excellent linearity make it ideal for PWM (pulse-width-modulation)-based control applications. **Figure 1** shows the basic circuit, which works as follows: When IC₁'s output goes high, switch S₁ closes, and IC₁'s internal discharge, switch S₂, opens. Capacitor C₁ charges through R₁ and R₂. When IC₁'s output goes low, S₁ opens, and S₂ closes, discharging C₁ through R₂ and R₃.

The generic configuration works well for producing a fixed-value duty cycle.

(continued on pg 86)

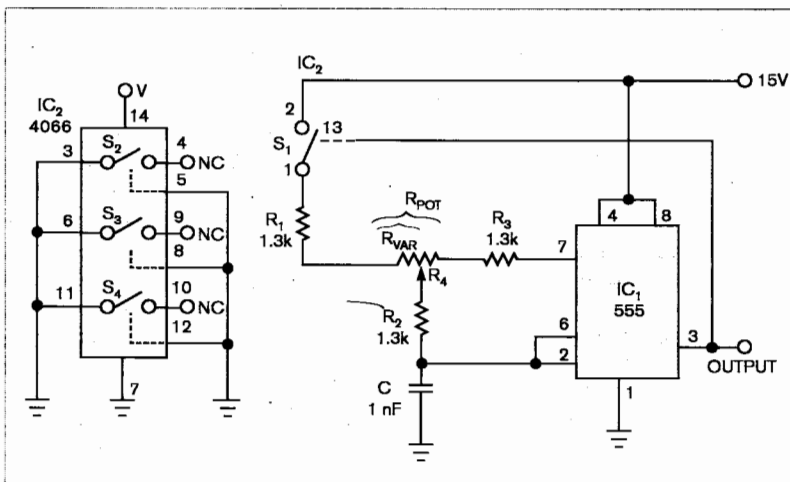

Figure 2 Add a potentiometer, R₄, to produce an output pulse that has a manually variable duty cycle.

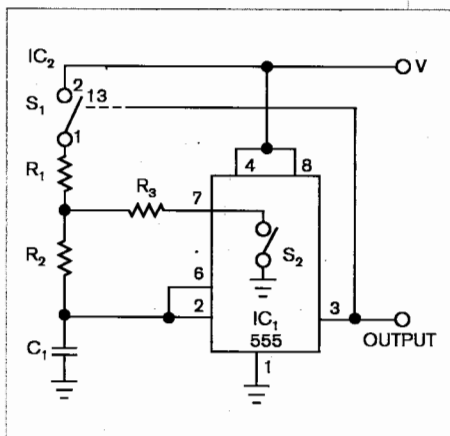

Figure 1 An external analog switch and a 555 timer provide a free-running oscillator with a fixed duty cycle.

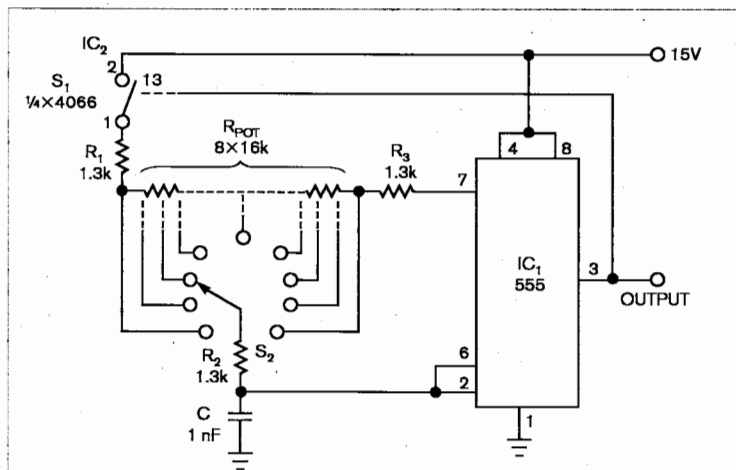

Figure 3 To obtain fixed-duty-cycle values for linearity evaluation, you can replace the potentiometer with a rotary switch and a series-connected string of precision resistors.

designideas

To obtain a continuously variable duty cycle, **Figure 2** shows how to connect potentiometer R_4 to the common junction of R_1 , R_2 , and R_3 . The output waveform's duty cycle, $D_T C$, follows the equation: $D_T C = (R_1 + R_2 + R_{VAR}) / (R_1 + 2R_2 + R_3 + R_{POT})$, where R_{POT} is the potentiometer's end-to-end resistance, and R_{VAR} is the fraction of R_{POT} between the rotor and R_1 . As the equation shows, $D_T C$ depends linearly on R_{VAR} . Switch S_1 comprises one section of a 4066 CMOS quad bilateral SPST switch, IC_2 .

You can use the circuit in **Figure 3**

to evaluate duty-cycle linearity. A rotary switch and a tapped series string of 16-k Ω resistors provide a 10-kHz signal with nine discrete, equally spaced duty-cycle values ranging from 2 to 98%. For accurate results, use a 5½-digit multimeter to match the values of resistors R_4 through R_{11} and a Tektronix 3012 oscilloscope or equivalent to gather $D_T C$ data.

Microsoft's (www.microsoft.com) Excel-spreadsheet software includes a linearity analysis that returns the following trend line for the duty-cycle measurements: $D_T C = 0.7565 \times$

$R_{VAR} + 2.1548$; $R^2 = 1$. The value of 1 for R^2 as Excel calculates shows that the transfer function is perfectly linear. Switch S_1 's on-resistance and particularly its leakage current slightly affect the $D_T C$ -versus- R_{VAR} equation's slope and intercept, but the equation remains strictly linear. Using only one of IC_2 's four switches eliminates leakage effects and crosstalk that would occur if other circuits used the remaining switches. In addition, using moderately low values for the resistor network further reduces leakage-current effects on circuit performance. **EDN**