

Traffic Light Control System

Ravi Kant Taxall

Traffic density on roads in big cities like Delhi, Bombay, Calcutta, Madras and Hyderabad has become so high that it requires a lot of planning for smooth flow of the traffic on the roads. Therefore, the traffic lights have been installed at almost all major traffic crossings in these cities.

Have you ever noticed the actual sequence of traffic lights at some busy crossing? Well, let us have a look at a traffic crossing and write down the sequence. Fig. 1 shows two roads—one in North-South (NS) direction and the other in East-West (EW) direction. In this figure we have not shown the lights at the South and East ends. Lights at the South and East ends are similar to lights at North and West ends respectively. So, when the traffic for South to North is open green lamp no. 3 is on, the North to South traffic will also be open. In other words, the lights at the two opposite ends are connected in parallel.

The typical sequence of lights and the duration of each step, as observed at one major traffic crossing in New Delhi, is given in Table 1. After taking a look at Table 1, one will realise that the present-day traffic control is not so simple.

The other part of the traffic control, which many readers may not be aware of, is also equally important for the smooth flow of the traffic on major roads, where one finds a road crossing after every hundred metres or so. This is called

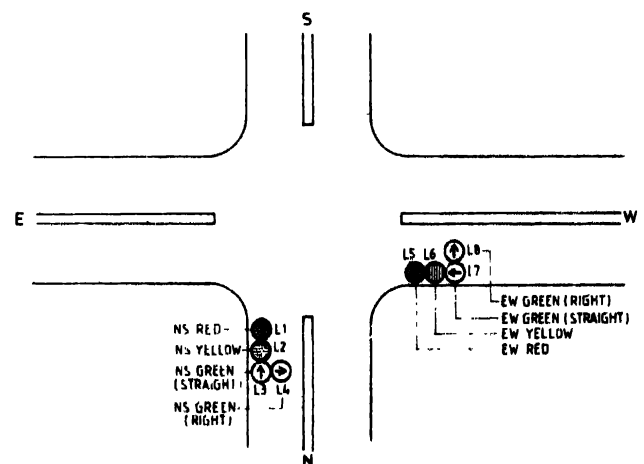

Fig. 1: Typical traffic light system on the road crossing.

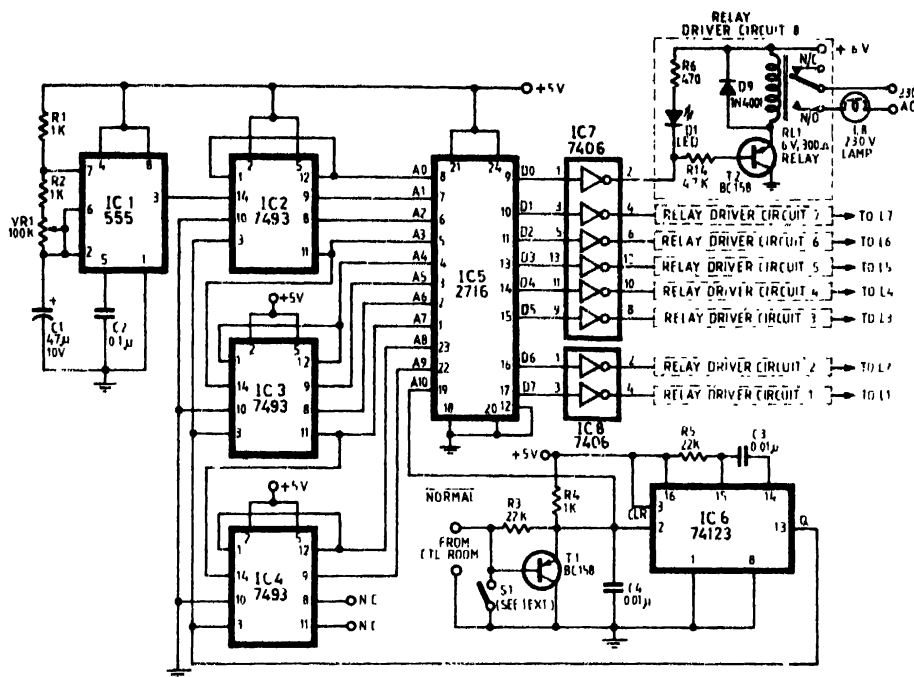

Fig. 2: Circuit diagram for traffic light control system.

PARTS LIST

Semiconductors:

- IC1 — NE555 timer
- IC2-IC4 — 7493/74LS93 divide-by-sixteen counter
- IC5 — TMS2516/2716 EPROM
- IC6 — 74123/74LS123 dual multivibrator
- IC7, IC8 — 7406 hex inverter
- T1-T9 — BC158 pnp transistor
- D1-D8 — 5mm red LED
- D9-D20 — 1N4001, 1 amp rectifier diode

Resistors [all 1/4 watt, ±5% carbon]:

- R1, R2, R4 — 1-kilohm
- R3, R5 — 22-kilohm
- R6-R13 — 470-ohm
- R14-R21 — 4.7-kilohm
- VR1 — 100k linear potentiometer

Capacitors:

- C1 — 4.7μF, 16V electrolytic
- C2, C6-C9 — 0.1μF, 12V ceramic
- C3, C4 — 0.01μF, 12V ceramic
- C5 — 4700μF, 25V electrolytic

Miscellaneous:

- S1 — SPDT switch
- RL1-RL8 — 6-volt, 300-ohm relay
- L1-L8 — 230V, 100-watt lamp
- PCB, IC sockets, LED holder, Lamp reflector, cables, enclosure, hardware etc.

'synchronisation' of various traffic lights through remote control. Here, the timings of various traffic lights at different crossings on one major road are adjusted in such a way that once the traffic finds 'green' light on the major (main) road, it should find green light at the next crossing too, if the traffic is moving at the recommended speed. The traffic control for the outer circle of Connaught Place of New Delhi is one such example.

The traffic light control system should also have the facility to operate in the so-called 'Hold Mode'. In this mode, the normal sequence of lights is discontinued and only yellow (or red) lights keep blinking to caution the traffic. The hold mode is normally used during late night hours or early morning hours, or when the traffic is to be controlled manually.

Now let us study a simple traffic light control circuit which uses a minimum of components. The circuit will be able to perform all the above-mentioned operations.

The circuit

The circuit for the traffic light control is given in Fig. 2. The suitable power supply for the system is given in Fig. 3.

The most familiar clock generator IC 555 is used in astable mode to generate the basic clock. The clock frequency can be adjusted by varying potentiometer VR1.

The circuit uses three 4-bit binary counter ICs, 7493 (74LS93) which are connected in cascade mode to generate the 'address' for the 2716 EPROM. The four outputs (O/Ps) of the first two counters (IC2 and IC3) and two O/Ps of the third counter (IC4) are used. This makes 10 address lines, which gives two, i.e. 1024 addresses (locations/combinations). So, if we want the traffic light cycle (step 1 through step 10) to take 128 seconds, the clock should be adjusted to 1024/128, i.e. 8 Hz or 0.125 seconds. Thus, we can control the traffic light with a resolution of 0.125 seconds.

Pin numbers 18 (chip select) and 20 (output enable) of the 2716 (IC5) are grounded. So, the 2716 chip is always selected. Now, depending on the address present at the address lines (A0 to A10), the 2716 will give out the data, which is already stored (programmed) at that address.

TABLE 1

Step	Lamp 1 NS Red	Lamp 2 NS Yel	Lamp 3 NS Grn	Lamp 4 NS Grn R Turn	Lamp 5 EW Red	Lamp 6 EW Yel	Lamp 7 EW Grn	Lamp 8 EW Grn R turn	Remark	Time Secs.
1	1	0	0	0	1	0	0	0	Both Roads Red	2
2	0	0	0	1	1	0	0	0	NS Red OFF; NS Grn (R Turn) ON	22
3	0	1	0	0	1	0	0	0	NS Grn (R Turn) OFF; NS Yel ON.	2
4	0	0	1	0	1	0	0	0	NS Yel OFF; NS Grn ON.	24
5	0	1	0	0	1	0	0	0	NS Grn OFF; NS Yel ON.	2
6	1	0	0	0	1	0	0	0	Both Roads Red	2
7	1	0	0	0	0	0	0	1	EW Red OFF; EW Grn (R Turn) ON	22
8	1	0	0	0	0	1	0	0	EW Grn (R Turn) OFF; EW Yel ON.	2
9	1	0	0	0	0	0	1	0	EW Yel OFF; EW Grn ON.	34
10	1	0	0	0	0	1	0	0	EW Grn OFF; EW Yel ON.	2
									Total	114

Abbreviations:

- 0 Lamp 'off'
- 1 Lamp 'on'
- NS Yel North-South Yellow
- NS Grn North-South Green (Straight)
- NS Grn (R Turn) North-South Green (Right Turn)
- EW Yel East-West Yellow
- EW Grn East-West Green (Straight)
- EW Grn (R Turn) East-West Green (Right Turn)

The O/Ps of 2716 are connected to the 7406 inverters. The 7406 is hex buffer/driver with open collector O/Ps, which can source/sink up to 30 milliamperes of current and the O/Ps can be connected to DC voltage up to 30 volts.

One light emitting diode (LED) is connected to the O/P of 7406 inverters through a current limiting resistor (R6). In our example, we have used 470-ohm resistor. In case the positive supply is not 6 volts (if some other relay with different coil voltage is used), the current limiting resistor should be modified accordingly. About 8 to 12 milliamperes of DC current is sufficient for a normal glow of the LED. So, if the

and testing of prototype, and are not required for the functioning of the circuit, and therefore may be eliminated, if so desired.

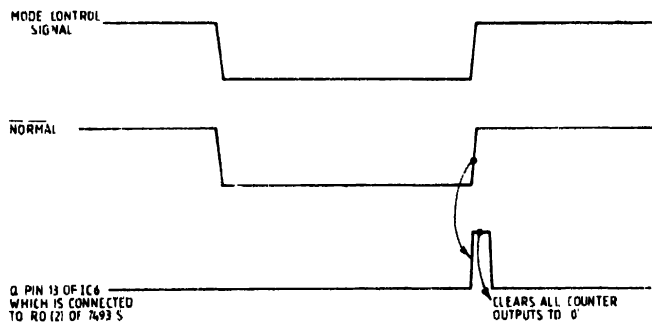

Fig. 3: Suitable power supply for the circuit.

positive supply voltage is 12 volts, R5 may be changed to 1k or 1.2k. Similarly, for 24 volts positive supply, a 2.2k resistor may be used. The LEDs are used only for visual indication

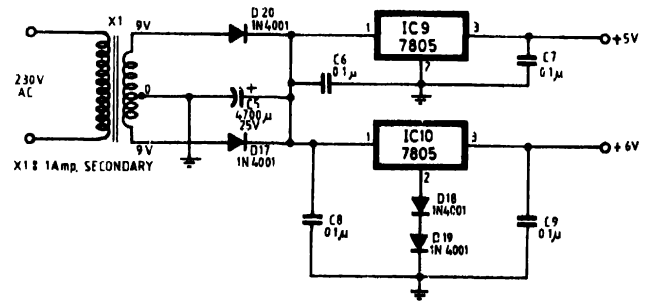

Fig. 4: Synchronisation timing waveform at various modes.

The base of a pnp transistor (T2) is connected to the O/P of 7406 inverter through a 4.7k resistor. The collector of the pnp transistor is connected to ground and a DC relay is connected through positive supply to its emitter. (In our example, we have used a 6V DC relay.)

So, when the O/P of 2716 chip is high (say, D0, i.e. pin 9 of 2716), it will be inverted and pin 2 of 7406 will become low. This will turn 'on' the LED and also transistor T2. Thus, the relay coil will be energised and lamp 8, which is connected through the relay contacts will turn 'on'. On the other hand, if the 2716 O/P is low, the 7406 inverter O/P will be high and

the LED as well as the transistor (and thus the relay) will remain off. Thus, we can control all the eight lamps in any combination.

The relay driver circuit in our example uses BC158 driver transistor. It will be suitable, as long as the coil current is less than 400 mA. In case some other DC relay is used, the driver circuit may have to be modified. In case the relay coil voltage is less than 30 volts and the coil current is less than 100 mA, the same circuit may be used. However, if relay coil voltage is less than 30 volts but the coil current is more than 100 mA, some other pnp transistor with higher power rating (say, ECP055) has to be used. But in case of more than 30V DC relay,

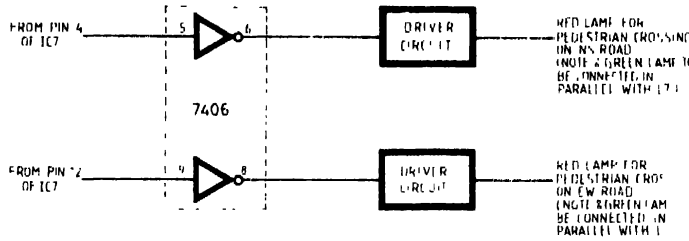

Fig. 5: Addition to main circuit to implement the pedestrian lights.

the 7406 IC cannot be used and a suitable driver circuit has to be redesigned.

Power supply

Power supply for the traffic control circuit is very simple as it requires only +5 volts. The power supply circuit uses one step-down transformer, two rectifier diodes D17 and D20), one filter capacitor (C5) and a +5-volt voltage regulator IC9 (7805 or equiv.). The voltage regulator should be mounted on a suitable heatsink.

The DC supply for the coils of the relays can be generated by using either an adjustable voltage regulator (78HG) or by simply connecting two diodes to the 'common' terminal of the 7805 voltage regulator, as shown in Fig. 3. The circuit will give around 6 volts DC supply.

The voltage regulator should be mounted on a suitable heatsink. The common terminal of the voltage regulator should be isolated from the heatsink. In case the relay coil voltage is other than 6 volts, a suitable power supply has to be designed for driving the relay coils.

Operation of the circuit

The operation of the circuit is very simple. As explained earlier, IC 555 generates the basic clock for the circuit, which is fed to a chain of three 7493s that generate 10 address lines for the 2716 chip. These lines are A0 through A9.

The 'mode control signal' which comes from the 'control room' is connected to the base of a transistor T1. If the base of T1 is open/high, the transistor will remain in cut-off state and the signal NORMAL, which is connected to A10 (the most significant address line) of the 2716, remains high. And, if the mode control signal is low, or if switch S1 is

closed, transistor T1 conducts and the signal NORMAL (A10) becomes low. The signal NORMAL is also connected to one monoshot IC 74123 (IC6). Its function will be explained in the latter part of this article.

As the 2716 has 11 address lines, it contains 2k, i.e. 2048 bytes of data. So, if the most significant address line (A10) is low, the lower 1024 (1k) address locations are selected (Address: 000 to 3FF hex). And, if A10 is high, the upper 1k addresses are selected (Address: 400 hex to 7FF hex). The lower 1k bytes are used to store data for hold mode and the upper 1k bytes are used for normal mode.

Now let us study the normal mode, the hold mode and synchronisation in detail.

Normal mode

As explained earlier, A10 is high during this mode and the upper 1k bytes are used to store data for this mode. The total time taken to complete one traffic cycle in our example (Table 1) is 114 seconds for all the 10 steps. This time has to be covered in 1024 clock cycles. Therefore, the clock frequency should be 1024/114, i.e. 9 Hz approximately.

The duration of step 1 is 2 seconds. So, 9×2, i.e. 18 addresses (locations) will be used to store the duration corresponding to step 1. Therefore, step 1 will start at address 400 hex and continue up to 411 hex (400 hex to 411 hex, both inclusive, is 18 locations), and since lamp 1 (bit 7) and lamp 5 (bit 3) should be 'on' (and rest all 'off'), '1000 1000', i.e. 88 hex should be stored at these address locations.

The duration of step 2 is 22 seconds, which will be covered in 22×9, i.e. 198 clock cycles. Since only lamp 4 and lamp 5 should be 'on' during step 2, the data '0001 1000' (18 hex) should be stored from 412 hex to 4D7 hex locations. Similarly, we can calculate the addresses and the data stored therein for other steps too. These values are listed in Table 2.

TABLE 2

Steps	Duration	Clock Cycles	Address (Hex)	Data (Hex)
1	2	18	400 - 411	88
2	22	198	412 - 4D7	18
3	2	18	4D8 - 4E9	48
4	24	216	4EA - 5C1	28
5	2	18	5C2 - 5D3	48
6	2	18	5D4 - 5E5	88
7	22	198	5E6 - 6AB	81
8	2	18	6AC - 6BD	84
9	34	306*	6BE - 71E	82
10	2	18	7EF - 7FF	84

* Actually 304 address locations are used so as to make the sum of the clock cycles, for all the steps, equal to 1024. This will reduce step 9 to 34×304/306, i.e. 33.78 seconds.

So, if the 2716 contains data as per Table 2, and A10 is high, the 2716 will continue to give data which will control the relays, which in turn finally control the traffic lights as per our requirements. The address will start at 400 hex and will keep on getting incremented, and the 2716 will keep on selecting new steps after required number of clock cycles

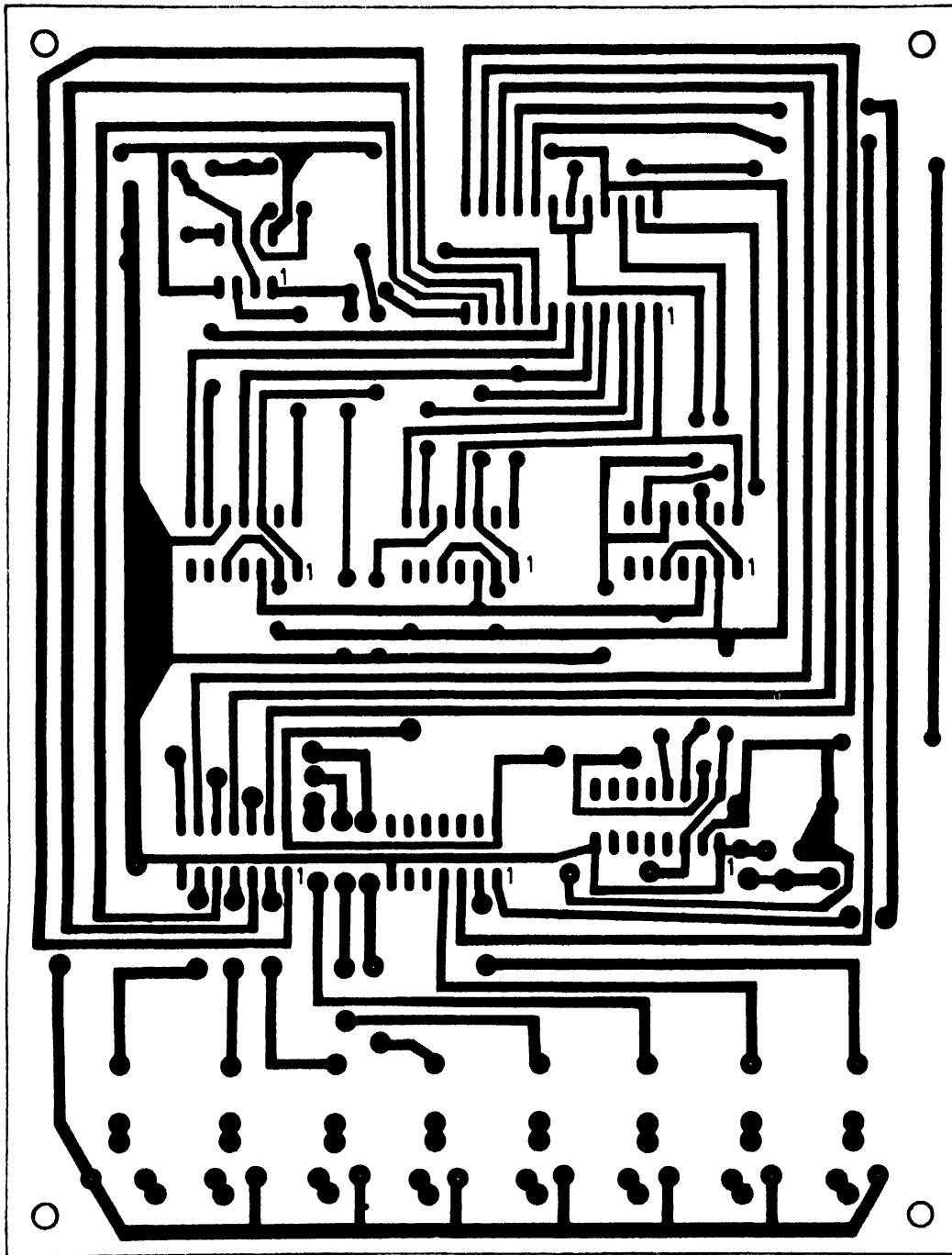

Fig. 6: Actual size PCB layout for the circuit.

when the current steps are over. When the address becomes 7FF (the last address for step 10; also last address of the 2716), it will once again become 400 hex at the next clock cycle. So, the traffic light will continue to run in normal mode.

Hold mode

The hold mode is similar to normal mode, except that the lower half of the 2716 (lower 1k bytes) is used and the A10 is low during this mode. The circuit can enter into this mode by closing switch S1 or by making 'mode control line' low through remote control.

In hold mode, the yellow lights keep on blinking. Let us fix the blinking rate to 0.5Hz, i.e. yellow lights are on for one second and off for the next one second. As per Table 1, lamp numbers 2 and 6 are used for yellow lights.

As we are using 9Hz clock, we should store '0100 0100', i.e. 44 hex data in the first 9 locations (000 to 008) and '0000 0000' should be stored in the next 9 locations, and then '44' hex in next 9 locations, and so on. This should be continued up to address 3FF hex.

Since in hold mode the A10 remains low, the address starts at '000' and is incremented up to '3FF'. Thereafter, it once again starts from '000'. So, in hold mode the yellow

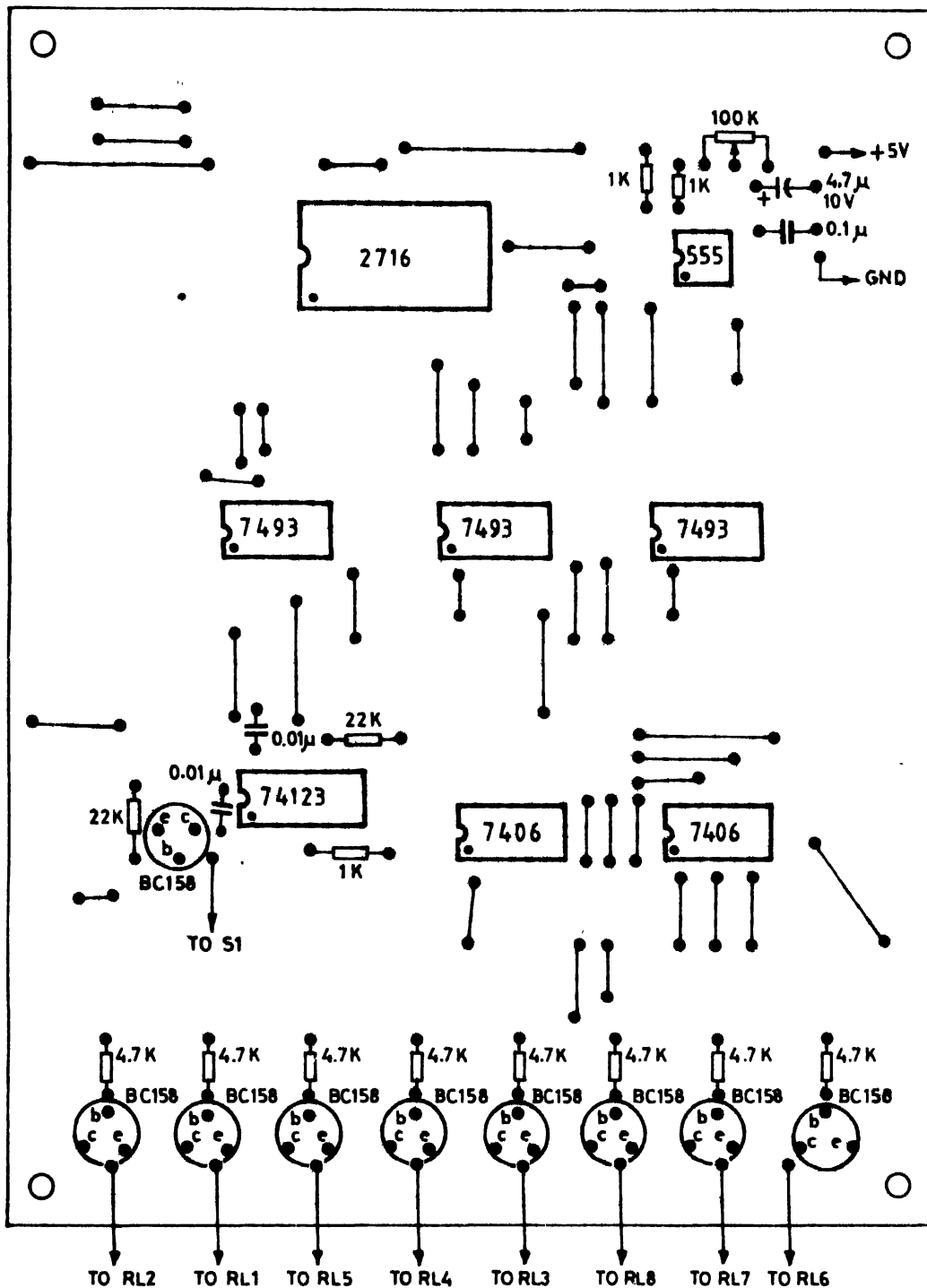

Fig. 7: Components layout for the PCB.

lights will keep blinking at 0.5Hz rate.

In case some other blinking rate is required, it can be easily achieved by varying the number of locations for lights that are on (data '44') and the lights that are off (data '00') in the 2716.

Synchronisation

Synchronisation means starting the traffic lights from step 1 at a particular moment, through remote control. As

explained earlier, this helps in smooth running of traffic on busy roads.

We have not explained the function of 74123 (IC6). The IC 74123 contains dual monoshots. Only one monoshot is used in this circuit. The circuit is configured in such a way that it triggers the monoshot at the 'positive going pulse' at 'B I/P' (pin 2 of IC6).

IC6 is used here for synchronisation. For using this feature, first we have to put the control circuit in hold mode by

making mode control signal 'low'. As a result, the $\overline{\text{NORMAL}}$ line becomes low. But this does not 'trigger' the monoshot of IC6, as the monoshot (IC6) is configured to trigger on high going pulse only. But when the 'low' level from the mode control line is removed, the $\overline{\text{NORMAL}}$ line goes from low to high. This triggers the monoshot and a 'high' pulse is generated at the 'Q O P' of 74123, which is connected to the 'R0' (pin 3) of the counters. This sets the O. Ps of all the counters to zero. The timings are shown in Fig. 4. So, the effective address applied to the 2716 chip is '400 hex' ($\overline{\text{NORMAL}}$ (A10) is high) and the control sequence starts from step 1. Thus, the traffic lights can be put in synchronisation by making mode control line low and then high at the desired moment.

So, we have seen that this simple circuit has all the features of a good traffic control system. It is also possible to have two 2716 chips in the circuit so that two traffic light control sequences are stored, and any one of the two sequences may be selected with the help of a simple switch. For doing this, all the pins of both the 2716 chips, except pin 18, should be joined together. Pin 18 of the two 2716 chips should be connected through a DPDT switch in such a way that the switch makes pin 18 of the first chip low (and that of the other chip high) when in one position and vice versa. Thus, the chip with a low pin 18 will be selected and the control sequence stored therein.

In case more than 8 O/ P lines are required, two 2716 chips

should be used in such a way that all the I/ Ps are common (i.e. A0-A10), Chip Select (18) and Output Enable (20)). Thus both the chips will be selected simultaneously and we can control up to 16 lights (8 through each 2716 chip) in any combination.

Many traffic lights give 'green/ red' signal for crossing the roads to pedestrians also. This is also possible in our original circuit. (Refer to Figs 1 and 2.) The pedestrian should cross North-South road only when there is no movement of traffic on North-South road from any direction. This condition is true only when the traffic is moving in East-West (straight) direction. Or in other words, when lamp 7 is on. So, light for the pedestrian who wants to cross North-South road should be green only when lamp 7 is on, and should be red for rest of the time. Thus, the green light in this case can be connected in parallel to lamp 7 and an inverter can be connected from pin 4 of IC7 (Fig. 2) and the O/ P of this inverter can drive the driver circuit for controlling red light for pedestrian crossing. A similar addition will be required for the pedestrian who wants to cross East-West road. This is shown in Fig. 5.

All the components used in this traffic control circuit are easily available in local markets. The circuit can be easily wired on a general-purpose PCB. But some readers may find it difficult to get the 2716 EPROM programmed. If they do not have access to a PROM programmer, they may contact EFY for pre-programmed EPROMs containing data as per Table 1. □