

Model railway points controller and indicators

This project employs a capacitive discharge type power supply to drive the solenoid actuators in model railway points switchers. An add-on indicator unit can be used in conjunction with it to show which way points are switched at any time.

Jonathan Scott

THE IDEA of using a capacitive discharge supply to drive the solenoids in model railway points switchers is not new. Indeed, you can buy these at hobby shops for \$20 or so, if you are not inclined to build one for yourself. However, this project incorporates refinements you may not have seen, along with a system of indicating the state of the points modelled after the fashion of the 'professional' signal box lighted map.

The capacitive discharge supplies bought 'over the counter' generally charge a capacitor of one to two thousand microfarads via a current limiting resistor from a rectifier and an ac source. This is quite adequate, but can be refined. If you charge the capacitor from a constant current source, it charges somewhat faster and one can provide an 'unready' indication while it's charging. The little extra speed one gains in charging is handy as several points often need to be changed in a short space of time and one's fingers dance from button to button when doing so.

With either system, the current limiting arrangement protects the solenoids against burnout if the supply happens to be accidentally connected indefinitely. The simpler system almost invariably incinerates something if you get a short somewhere.

The idea behind the capacitive discharge method is simply that the point changes in the first hundred milliseconds or so, any other power delivered is wasted. The high momen-

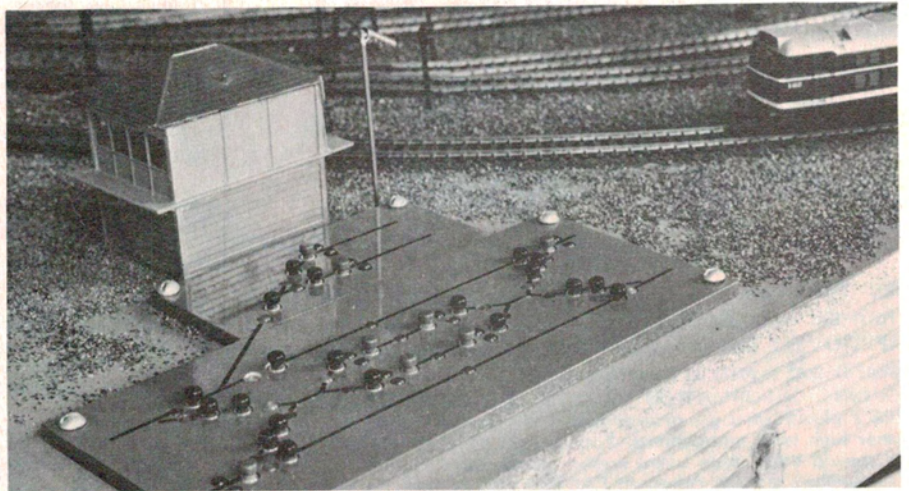

Signal map. This shows a view of one of my signal maps with the points pushbuttons and indicator LEDs installed.

much less than the current required to actuate the solenoid. Thus, the solenoid remains cool even if connected (by some accident or other) indefinitely, avoiding burnout of the solenoid.

The outline of a capacitive discharge supply is shown in Figure 1, along with the outline of a 'remote point indicator', or 'remoter'.

The remoter is simply a 'memory' circuit which records which way the point was last changed. I used a simple flip-flop for this. Two LEDs or lamps are used to indicate the point's condition. These may be built into a signal map panel. This is basically just a line diagram of a track layout, or part thereof, with lights and switches in the symbolic positions of the actual points on the track layout. Train signal lights are also usually included on the map along with train position sensors, if used.

There is, of course, no need to have remoters. They are purely conveniences, rather than necessary functional items. Remoters are primarily important if you wish to have a layout which is as much like the 'real' thing as possible. However, for the few dollars or so extra cost each, they add a very pleasing touch of realism.

You can have any number of points in your layout and you'll only need one capacitive discharge supply unit. The one described can easily drive three points simultaneously if you need to operate some points together. One remoter is needed for each set of points.

Construction

Construction is relatively brief. The only part we can really cover here is the assembly of the pc boards and with the usual exhortation "assemble the boards according to the overlays", it's nearly all over!

There are two pc boards: ETI-1510a is the capacitive discharge supply, and ETI-1510b is for the remoters. Let us take the supply board first. It is easiest to mount the diodes and resistors first, then Q1 and IC1, followed by the capacitors. Take care with the orientation of the diodes and transistors as well as C1 and C2. Note that Q1 and IC1 should have heatsinks attached. You can make these from a scrap of aluminium; each heatsink should be at least 25 sq. cm in area. They can be bolted straight to the metal face of each device, but don't forget to smear on thermal compound first.

You may or may not wish to mount the 'charging' LED (LED1 on ETI-1510a) off the

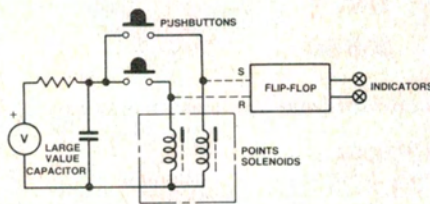

Figure 1. The controller/indicators scheme.

tary current capability of a capacitor means that the solenoid always moves quickly. When you connect the charged capacitor to the points solenoid it will deliver a very high current which rapidly subsides to nothing or, at worst, the charge current which can be

PARTS LIST — ETI-1510a

Resistors all 1/2 W, 5%
 R1 2R7
 R2 1k2

Capacitors
 C1 1000u/25 V RB electro..
 C2 3300u/25 V axial electro..
 C3 10u/6 V tant.

Semiconductors
 D1-D6 1N4001/2/3/4 etc
 LED1 TIL220R red LED
 IC1 7805
 Q1 BD140

Miscellaneous
 ETI-1510a pc board; hookup wire, etc.

Price estimate \$8 — \$10

PARTS LIST — ETI-1510b

Resistors
 R1, R2 see text, circuit
 R3, R4 see text, circuit
 R5, R6 100k
 R7, 8, 9, 10 47k

Capacitors
 C1, C2 100n greencap

Semiconductors
 LED1 TIL220Y yellow LED
 LED2 TIL220G green LED
 Q1, Q2 BC549

Miscellaneous
 ETI-1510b pc board; hookup wire, etc.

Price estimate \$4 — \$5

Capacitors

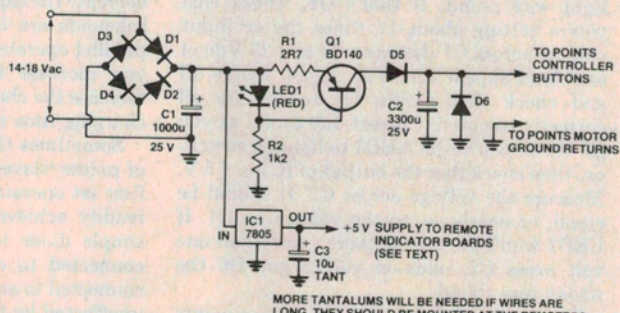
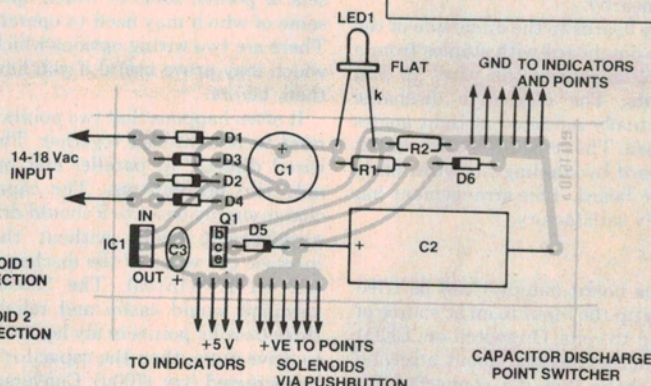
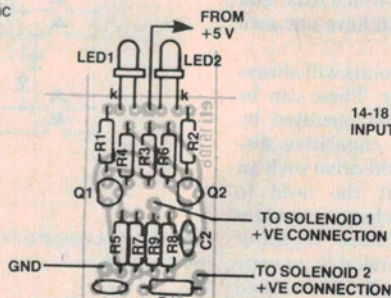
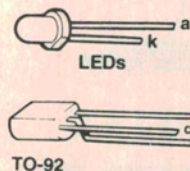
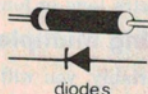
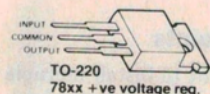
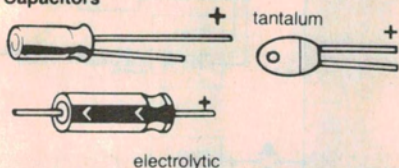

R1, R2	R3, R4
FOR +5 V 150R	22k
FOR +8 V 330R	33k
FOR +12 V 560R	47k

HOW IT WORKS — ETI-1510

There are two distinct parts to the project: the first is a capacitor discharge supply used to operate the point solenoids, the second is a remote indicator unit.

The capacitor discharge supply unit charges a capacitor which is then discharged into the point solenoid, which then operates the points. This unit is capable of changing one point every half second or so, and can power a large number of points together.

The remote indicator unit, or 'remoter', has the job of 'remembering' which way the point set was last switched and indicates the direction with a pair of LEDs mounted as part of a signal map.

Consider the capacitor discharge unit. Diodes D1-D4 rectify the 14-18 volt ac input to provide a dc supply. Capacitor C1 smooths this for IC1 which regulates the voltage supply for the remoters. Up to fifteen remoters can be run off the output of IC1.

Transistor Q1 and surrounding components form a current source which charges C2 via D5. LED1 forms the voltage reference and doubles as an indicator which illuminates for the time when the capacitor is being recharged

after use. Diode D5 prevents reverse biasing of the transistor when C2 is charged and C1 is below the peak input voltage value.

Using a current source for the charging element removes the need for a large series resistor and speeds up recharging as well as making the system short circuit proof.

Diode D6 is a "freewheel" diode which prevents possible reversing of the polarisation of C2 by the flyback voltage of a solenoid.

When a button is pressed, making a connection from the output of the unit to a point solenoid, C2 discharges into the coil, changing the point. After C2 is discharged the only current flowing through the coil is the recharge current of about 375 mA. When the button isolates the point solenoid, the current is free to charge C2, which takes about quarter of a second. When C2 reaches the input voltage, Q1 saturates, LED1 goes out, and the unit is ready to operate again.

The 375 mA charging current is insufficient to harm a solenoid if it is left connected for any reason. As the controller can withstand indefinite shorting itself, the whole system is protected against abuse and failure of

switches, etc.

Each remoter consists of an R/S type flip-flop formed by two transistors. Assume initially that Q1 is on, and Q2 off. The collector current of Q1, via R1, illuminates LED1, and the saturation collector voltage of Q1 ensures that Q2 remains off.

When a solenoid is activated by the discharge of the capacitor, a large voltage spike appears across it. Suppose that the voltage across the coil appears on R10. Capacitor C2 filters out brief induced spikes, so that no signal other than the correct one can affect the circuit. When the longer duration discharge pulse appears on R10 some current reaches the base of Q2, turning it on. This turns on LED2 via R2 and removes the base drive from Q1, and it turns off. Thus LED1 goes out, and the collector voltage on Q1 keeps Q2 turned on via R3. The reverse operation occurs when a pulse appears on R9.

Transistors are used rather than an IC as they have a higher output drive, are less intolerant of supply voltages and ICs normally have more than one flip-flop in each package and you waste the rest.

board; like on the front panel of your controller, for example. This is a good idea if other people are using your layout as it helps them allow for the necessary delay between point switching operations of about half a second or so. Make sure you wire in LED1 the right way round.

The remoter board (ETI-1510b) is quite straightforward. Best way to tackle this one is to mount the resistors and capacitors first. Then mount the two transistors making sure you get them the right way round. Finally, mount the two LEDs. Leave their leads long as the board can actually 'hang' from them. Alternatively, the LEDs may be mounted off the board and the board mounted somewhere conveniently nearby.

I secured my boards to the underside of the model railway baseboard with staples from a staple gun holding down the wires to and from the units. The capacitive discharge supply was actually mounted at right angles to the baseboard. The remoters were held flat on the baseboard by stapling the wires fairly close to the pc board. This arrangement has proved entirely satisfactory.

Trying out

The ETI-1510a board (supply) can be tried out first. Hook up the input to an ac source of between 14 and 18 volts. On switch-on, LED1 should light then extinguish about a second later. If not, check that it's connected the right way round. If that's OK, check that you're getting about 1/2 times the ac input voltage across C1 (between 20 and 25 Vdc or so should appear across it). If not, switch off and check that diodes D1 to D4 are all correctly oriented. Correct any faults as you go. When you've got LED1 to light on switch-on, then check that the output of IC1 is +5 V. Measure the voltage across C2. It should be equal, or nearly so, to the voltage on Q1. If LED1 won't go out, or there's less than one volt across C2, odds-on you've got D6 the wrong way round.

Temporarily hook up the supply to a points solenoid and see that it operates as expected.

You can check out the remoter(s) by temporarily connecting it to the +5 V from the supply board. One or other of the LEDs will light. Say LED2 on the remoter lights. Connect the 'SOLENOID 1' input momentarily to the positive terminal of C2 on the

supply. LED1 should light and LED2 should extinguish. If not, check transistor and LED orientations. If this works, then temporarily connect the 'SOLENOID 2' input to the positive terminal of C2 and the LEDs should swap over.

When wiring in the remoters, it may be necessary to add some extra supply bypassing to prevent random toggling of the LED indicators. Add a tantalum with a value between 4u7 and 10u. You'll need one of these per extra metre of cable length if the cable is a metre long or longer.

Wiring multiple points

Invariably, you will want to install multiple sets of points, some of which operate alone, some of which may need to operate together. There are two wiring options which exist and which may prove useful if you have not seen them before.

It often happens that two points will always need to be switched together. These can be wired directly in parallel and operated by only two pushbuttons. The capacitive discharge supply described should drive such an arrangement easily, without the need to increase the value of the discharge capacitor (C2 on ETI-1510a). The 3300u capacitor specified would easily and reliably operate three parallel points in my layout. If you need to drive more, then the capacitor's value can be increased (try 4700u). Conversely, you can decrease the capacitor's value if you find your solenoids are light ones and/or don't have parallel operated points. Don't forget that, if you increase the capacitor's value, you'll increase the charging time. If you decrease it, charging time speeds up.

Sometimes there is a need to have one set of points 'slaved' from another, but have the first set operated independently also. This is readily achieved by the inclusion of some simple diode logic. A diode with its anode connected to one solenoid and its cathode connected to another will leave the first point unaffected by the second when switched, but will ensure that when the first is switched, the second also operates. This can be implemented with ordinary silicon rectifier diodes such as EM401s, 1N4001s, etc.

The various wiring arrangements are illustrated in Figure 2.

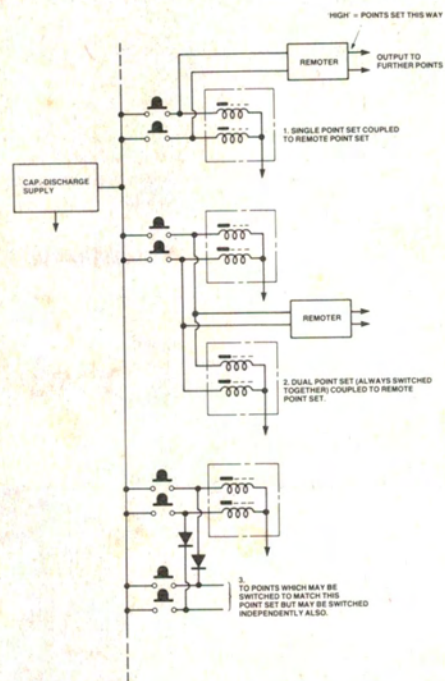

Figure 2. Showing the three fundamental schemes for wiring points.

Logic output

One advantage of remoters is that they can output the state of a point set as logic levels for feeding into a digital system or computer. Astute readers will have noticed a certain provision in these model railway projects for a computer interface. The collectors of the transistors in each remoter circuit give a 'low' voltage when the respective side is that one carrying the traffic. For a 5 V supply, the levels are TTL. This is the main reason that the remoters are run from a carefully regulated supply, apart from a desire to keep LED illumination level fairly constant. For those needing CMOS or other levels the resistor values for 8 V and 12 V supplies are shown on the diagrams. (R1-2 and R3-4 will vary.)

Coupled with position sensing systems, the remoters can allow a simple anticrash logic system to be hardware implemented!

Printed circuits. Full size artwork of the two pc boards.

