

Experimenter's Interface Device

Simple add-on device lets you explore electronic control with your home computer

By Kendra R. Bonnett
& Dovell M. Bonnett

Fighting off alien invaders, running household budgets, and playing music on your home computer certainly has appeal—at least initially. But once this attraction has worn off, some people may come to regard their home computer as little more than an expensive door-stop. If so, you may be ready for another dimension in home computing—electronic control. If you're imaginative, you'll soon find that the applications to which you can put your

computer are far-ranging. For example, you can use your computer as a digital multimeter, an electronic thermometer, a home security system, or even a computerized weather station, to mention just a few applications.

Applications to which you can put your computer are limited only by your imagination and technical expertise. All you need, aside from knowing what to do and how to go about doing it, is the data on your computer's input/output (I/O) port and an interface, such as the Experimenter's Interface Device that will be described here. This EID offers fully buffered I/O lines between the inter-

face and your computer, its own 5-volt dc power supply, a breadboarding area for building your own hardware projects, and an interface cable.

The Experimenter's Interface Device is designed to connect to the 24-pin user port of the Commodore 64 computer. However, it can easily be adapted to use with other home computers.

(1) Identifying User Port Pins

Before you can design an interface, you must determine the function of each pin on the input/output (I/O) port, direction of signal travel through each pin, and whether or not

Photo shows completed project, with interface cable attached. The large white area on top of box is a solderless breadboarding block on which experimental circuits are assembled. Smaller white blocks in cutout area are for distributing power and input/output lines per circuit requirements.

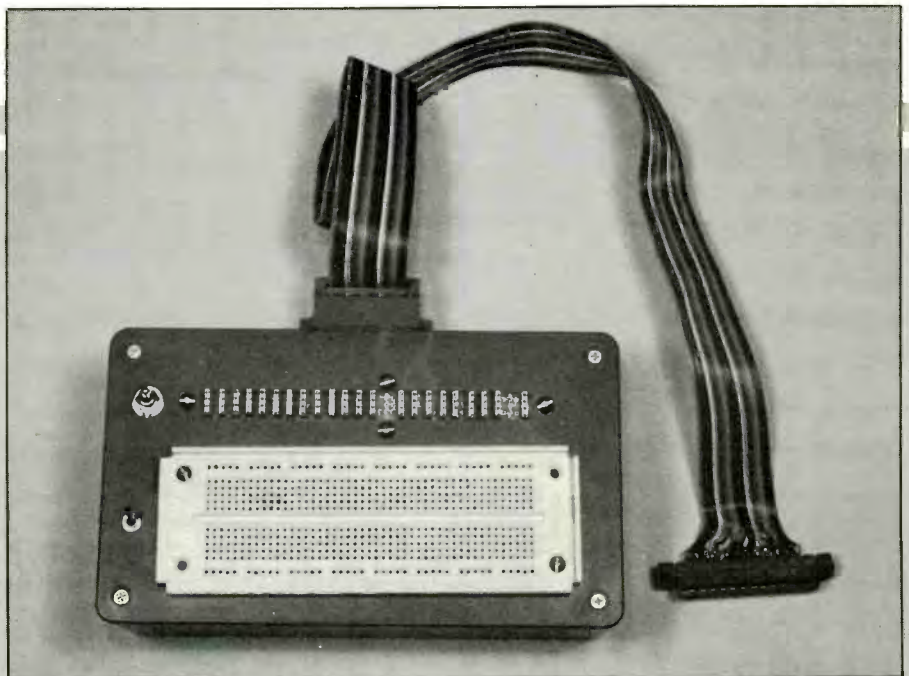

buffering is needed. It helps to keep a journal or notebook when starting a project like this.

Most of the information you need concerning the user port can be found on pages 360 and 421 of the *Commodore 64 Programmer's Reference Guide* (available from Commodore Business Machines, Inc. and Howard W. Sams). This information is summarized in Table I. Note in the table the shorthand notations "bi" and "uni" in the column headed "direction." Here, "bi" means bidirectional, indicating that data can travel from the computer to an external device and from the external device to the computer (but not both ways simultaneously). Similarly, "uni" means unidirectional, indicating that data can flow in only one direction, either into or out of the computer. Using conventional current-flow theory, the "in" will receive (sink) current into the computer, while "out" will transmit (source) current from the computer.

(2) Selecting The Buffer ICs

Because the four ground (GND), +9V, -9V, +5, and RESET pins are used to power other devices, and not

as control or data lines, they do not require buffering. All remaining pins, however, do require buffering—14 bidirectional and two unidirectional buffers in all. Two 74LS245 bidirectional and one 74LS367 unidirectional buffer ICs are almost ideal for this application.

One pin on the 74LS245 provides control over the direction in which data travels through the buffers. Both ICs have a pin that allows the chips to be enabled and disabled. By wiring these control pins to switches and powering the chips with a 5-volt power supply independent of the computer's 5-volt dc output (see Fig. 1), you can change the direction of signal flow and enable and disable the buffers with two switches.

Buffers serve two important purposes in the Experimenter's Interface Device. First, they protect the computer from any outside voltage that may occur as you're experimenting with external circuits on the project's breadboard. By isolating these voltages, you prevent your computer from damage simply by turning off (disabling) the buffers so that no voltage can enter the system. Second, long wires have resistances, which create voltage drops between the computer and external device. Buf-

PARTS LIST

Semiconductors

IC1—LM 340 5-volt regulator

IC2—74LS367 hex bus driver

IC3, IC4—74LS245 octal bus transceiver

Capacitors

C1—0.22- μ F epoxy

C2—0.1- μ F tantalum

Resistors

R1—1,000-ohm, 1/2-watt, 10% resistor

Miscellaneous

S1—Dpst toggle switch

S2—Spst toggle switch

Wire Wrap sockets (two 20-pin, one 16-pin); 9-volt dc, 500-mA ac adapter (Radio Shack No. 273-1651); subminiature jack (Radio Shack No. 274-297); experimenter's IC perfboard (Radio Shack No. 276-150); TO-220 heat sink (for IC1); solderless female DB-25 connector; chassis-mount male DB-25 connector; 24-contact pc-board edge connector; 36" or so 24-conductor ribbon cable; blank (no copper cladding) perforated board with 0.1" hole centers (one each 6" \times 4 1/2" \times 2 3/4"); large solderless breadboarding socket; 2 pks. 4-contact Klip-S-rip solderless terminal blocks (Vector Electronic No. T45-4DP); 7 1/2" \times 4 1/2" \times 2 1/2" plastic utility box; self-stick rubber feet; yellow, red and blue 30-gauge Kynar-insulated wire; red and black 22-gauge stranded hookup wire; Wire Wrap socket ID tags (optional); 5-32 machine hardware; plastic board separators (8); solder; etc.

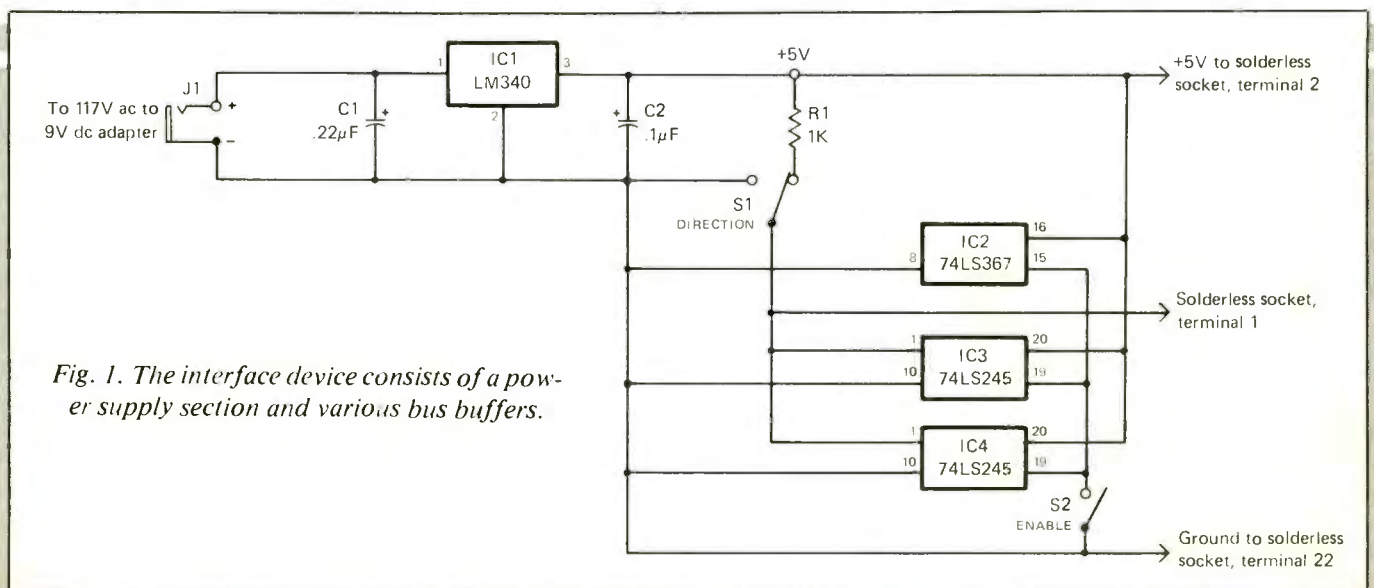

Fig. 1. The interface device consists of a power supply section and various bus buffers.

fers help keep signals true and actually amplify the signal if necessary.

Tri-state noninverting buffers, such as those specified in the Parts List, are a good choice because they can be enabled and disabled by a separate pin on the buffer ICs without having to physically disconnect the interface device from your computer.

(3) The 5-Volt Power Supply

According to the data sheets, the V_{cc} supply voltage required by the buffer ICs is 5 volts dc. For the 74LS245s, maximum current drain (I_{cc} is specified at 105 mA, while that for the 74LS367 is 24 mA. The maximum total current demand of the three ICs, then, is 234 mA ($105 + 105 + 24 = 234$ mA), which is more than twice the 100-mA current available from the C-64 computer at its +5-volt user-port pin. It should be obvious, then, that a 5-volt dc power supply, independent of the C-64's +5-volt line, is needed for the Experimenter's Interface Device.

You can make an independent +5-volt dc power supply with a commonly available dc adapter (see Parts List) that converts 117 volts ac to 9

PIN	FUNCTION	DIRECTION	BUFFER	REMARKS
1	GND	uni (in)	none	connect all grounds
2	+ 5 V dc	uni (out)	none	100 mA maximum
3	RESET	uni (out)	none	
4	CNT1	bi	74LS245	control line
5	SP	bi	74LS245	control line
6	CNT2	bi	74LS245	control line
7	SP2	bi	74LS245	control line
8	PC2	uni (out)	74LS367	control line
9	SERIAL ATN	bi	74LS245	control line
10	+ 9 V	uni (out)	none	
11	- 9 V	uni (in)	none	
12	GND	uni (in)	none	connect all grounds
A	GND	bi	none	connect all grounds
B	FLAG2	bi	74LS367	control line
C	PB0	bi	74LS245	data line
D	PB1	bi	74LS245	data line
E	PB2	bi	74LS245	data line
F	PB3	bi	74LS245	data line
H	PB4	bi	74LS245	data line
J	PB5	bi	74LS245	data line
K	PB6	bi	74LS245	data line
L	PB7	bi	74LS245	data line
M	PA2	bi	74LS245	data line
N	GND	uni (in)	none	connect all grounds

bi = bidirectional; uni = unidirectional

volts dc and a garden-variety 5-volt IC voltage regulator. This arrangement gives you 5 volts dc at 500 mA, which is more than enough for powering the buffer ICs.

Begin building the power supply

by drilling the four $\frac{3}{16}$ " holes in the corners of the experimenter's IC perfboard, as shown in Fig. 2. If your perfboard already has small holes in the corners, do *not* try to enlarge them with a drill. Instead, move in about $\frac{1}{4}$ " and start fresh. This done, lightly rub the copper traces with fine steel wool until they are shiny bright, to remove oxides.

Bend the leads of voltage regulator *IC1* back toward the rear, about $\frac{1}{8}$ " from where they exit the body of the IC, forming a 90° angle with each. Then mount the heat sink to the back of the IC with its fins pointing up. Use a 6-32 \times $\frac{1}{4}$ " machine screw and nut to secure it in place.

Insert the three regulator leads into three adjacent three-hole pads on the perfboard and solder them to the holes in the pads closest to the edge of the board. (This and all subsequent steps are illustrated in Fig. 2.)

With *IC2* in place on the board, the long multiple-hole bus nearest the pads to which it is soldered serves as the system ground bus. Connect and

Fig. 2. Drawing illustrates details for assembling power supply module.

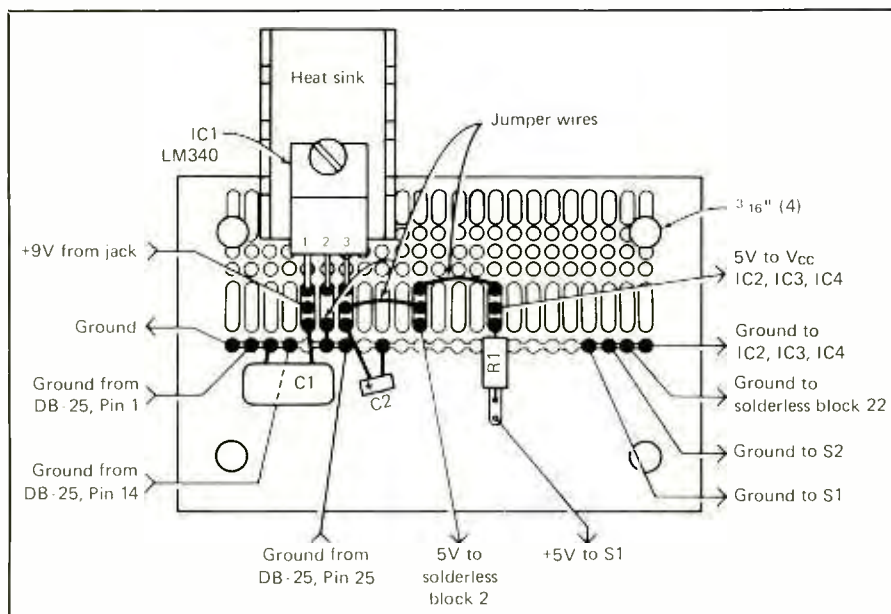

solder a short wire jumper from the IC2 pin 2 pad to the ground bus. Similarly, connect and solder C2 from the IC1 pin 1 pad to the ground bus and the long positive lead of C2 (the capacitor's case is also usually marked with a plus sign to identify the positive lead) to the IC1 pin 3 pad and the negative lead to the long multiple-hole ground bus.

Solder a short wire jumper from the IC1 pin 3 pad to another three-hole pad and a second wire jumper from the latter pad to yet another three-hole pad. Then install RI from the bottom hole in this last pad to another three-hole pad below the ground bus. (This is a current-limiting resistor, used to protect the ICs by limiting the current coming through direction control switch SI.)

Strip ¼" of insulation from two red and two black wires, each 7" long. Tightly twist together the fine wires at each end and tin with solder. Insert one end of the two black wires into one of the free holes at the left and right of the ground bus and solder. Solder one end of a red wire to the IC1 pin 1 pad and one end of the other red wire to the free hole in the pad to which RI and the wire jumper are connected. (The red wire connected to the IC1 pin 1 pad and black wire at the left end of the ground bus are the positive and negative leads, respectively, for the 9-volt adapter jack. The other red and black wires connected to the RI pad and right side of the ground bus are the +5-volt and ground outputs from the power supply to the buffers.)

The 9-volt dc adapter comes with two different types of plug sockets. Connect the ⅝" solid shaft one to the end of the adapter. Insert the shaft into the jack and plug the adapter into an ac outlet. (Don't worry, you won't get a shock.)

Set a dc voltmeter for a full-scale deflection of slightly greater than 9 volts. Connect the meter's common lead to one post on the jack and briefly touch the positive lead to the other

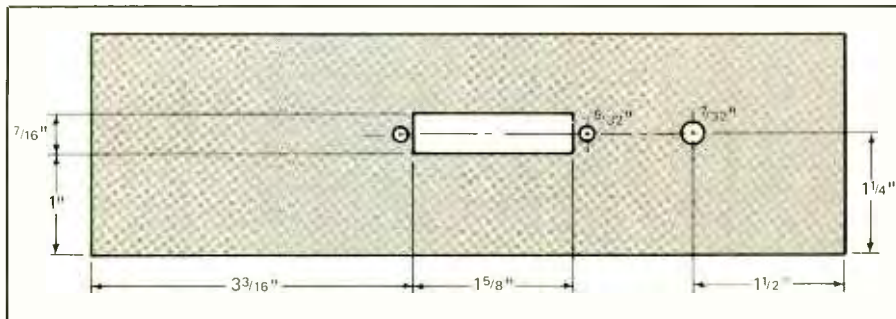

Fig. 3. One long wall of the box in which the interface device is housed must be machined to accommodate the D connector and ac adapter jack.

jack post. If you get a negative reading, reverse the leads. The indication you're looking for is +9 volts. When you get this, the common lead is connected to the negative jack post. Make a note of this. Then unplug the adapter from the ac outlet.

Solder the red wire coming from IC1 pin 1 to the positive jack post. Then solder the black wire from the left end of the ground bus to the other jack post.

Once again plug the adapter into an ac outlet and the adapter into the jack. Connect the voltmeter to the free ends of the other red and black wires (positive to red and common to black) and observe the meter reading. The reading should be close to 5 volts. (Warning: If you remove the small plug socket from the shaft of the ac adapter, be sure you replace it exactly as it was. Otherwise, you risk reversing the negative and positive leads and damaging your 5-volt dc power supply.)

Insert the short ends of the plastic separators into the four holes you drilled in the power supply board. Temporarily set aside the power supply module.

(4) Preparing The Box

The plastic box specified in the Parts List will readily accommodate all the parts that make up the Experiment er's Interface Device proper. A plastic box is recommended for two reasons. First, it is much easier to machine than metal. Second, it will not

short any circuitry or wiring that might come in contact with it.

Preparation of the box is detailed in Fig. 3. It consists of cutting a slot for a DB-25 connector and drilling its mounting holes and drilling the mounting hole for the adapter jack. After removing the top of the box, draw the outline of the connector slot and indicate where to drill the hole for the adapter jack. The slot cuts easily with a coping saw. To get started, drill a ¼" hole in the center of the slot area. Then use the saw to trim away all unwanted plastic. Finish the job with a file. (You want the connector to fit snugly in the slot. So don't overdo the sawing and filing.)

Set the chassis-mount male DB-25 connector into the slot and trace its mounting-hole outlines onto the box. Remove the connector and drill the two ⅜" holes. Change to a ⅜" bit and drill the hole for the adapter jack. Test fit the jack. If the fit is too light, use a reamer or small round file to slightly enlarge it. Don't mount the jack yet.

(5) The Buffer Section

Using Fig. 4 as a guide, drill the four ⅜" holes for the plastic separators and the two ⅜" board-mounting holes in the 6" × 4½" perforated board. Cut the long pins off the remaining four plastic separators and set aside the separators.

Set the power supply module on the perforated board, positioned so that the edges of the module line up

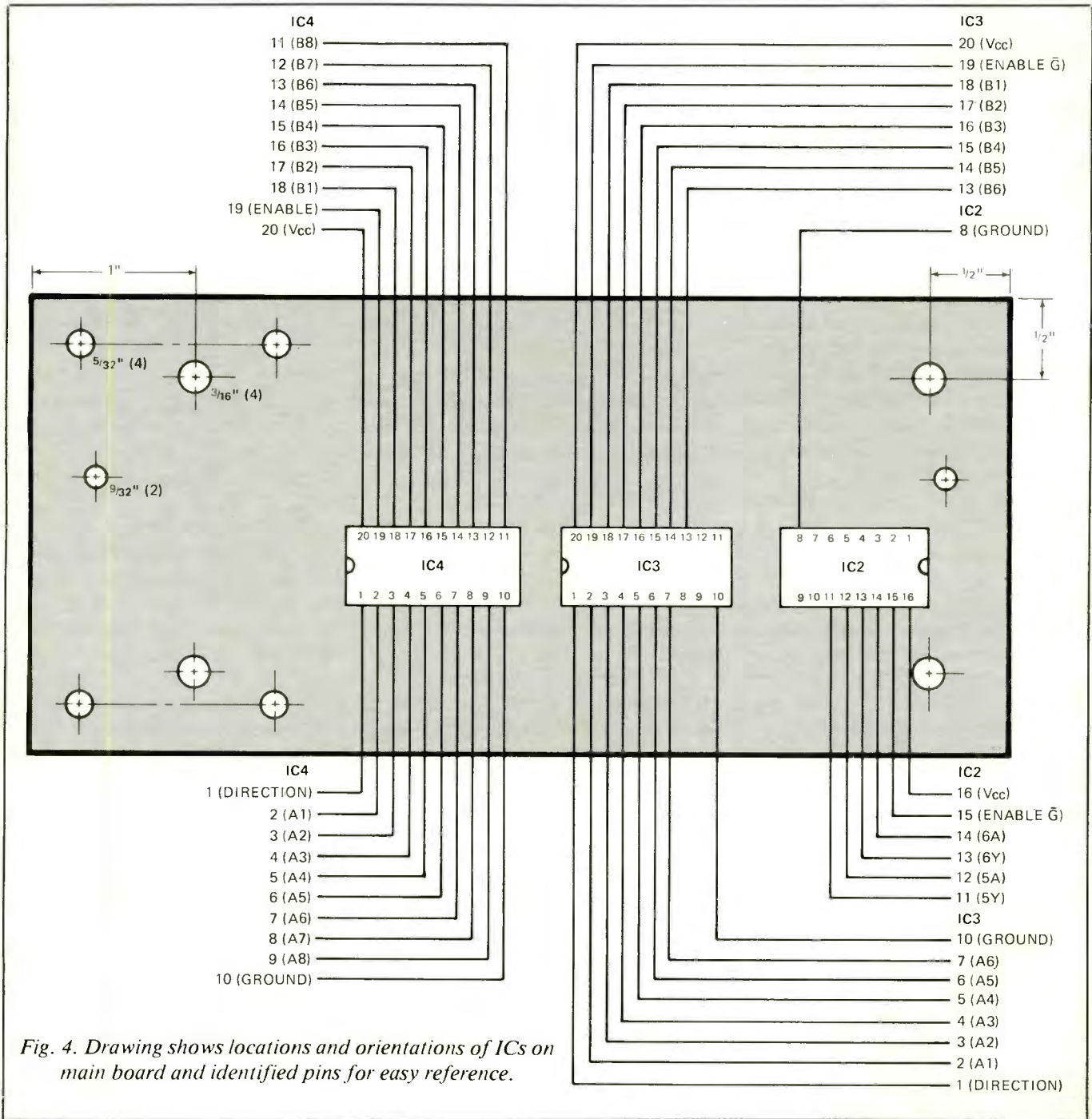

Fig. 4. Drawing shows locations and orientations of ICs on main board and identified pins for easy reference.

with the edges of the board. Each of the long pins of the module will sit in a hole on the board. Therefore, mark the locations of the separators on the board, remove and set aside the power supply module, and drill the four $5/32"$ holes at the marked locations on the perforated board.

Locate and drill the $1/4"$ holes at the

ends of the perforated board. The locations of these holes aren't critical. Just make sure the hardware used for the hole at the right end of the board will not touch the IC2 socket that will be mounted nearby.

Set the power supply module on the perforated board but don't push the pins of the plastic spacers home

yet. Orient the plastic box with the connector slot facing away from you. Place the perforated board and power supply inside the box, with the latter to your right. Make sure nothing touches the sides of the box. Holding the perforated board in place, remove and set aside the power supply module and trace the loca-

tions of the 1/4" holes onto the floor of the box. Remove the board and drill these holes.

(6) Wiring The Buffers

Wiring of the buffers is done in three stages, working first on the input, next on the output, and finally on the power supply and switch connections. In input and output wiring, keep the wires 7" long to provide enough slack for maneuvering parts when the circuit is disassembled.

Install a 20-pin Wire Wrap socket on the perforated board in the IC4 location (see Fig. 4). Orient the socket so that pin 1 is in the bottom-left corner with the layout shown. Insert the other 20-pin socket in the IC3 location and the 16-pin socket in the IC2 location. Note that pin 1 for IC3 is in the lower-left corner, while pin 1 for IC2 is in the upper-right corner. Leave enough space between the IC2 socket and the screw hole at the end of the board to prevent a washer and screw used here from touching the socket. You may want to slip Wire Wrap ID tags over the socket pins for easy identification during wiring.

Use yellow 30-gauge Kynar wire to interconnect the pins of the male DB-25 connector and the pins of the Wire Wrap sockets. (Refer to Figs. 4 and 5 and the Master Wiring Chart in Table II.) Strip 1/8" of insulation from one end of each wire that is to be connected to the DB-25 connector but leave the other ends as they are.

Keep in mind that bare wire exposed beyond the solder terminals on the connector could cause short circuits. So try to have the insulation come right up to the solder, and use only enough solder and heat to assure electrically and mechanically secure connections.

Feed the wires through the slot in the box to the connector and down through the holes from the top of the board in line with the pins on the IC sockets to which they are to connect. Use the holes located two spaces away from the pins.

Table II. Master Wiring Chart

Input	Output	Connect To	Function
IC4: pin 1		S1 toggle	direction control
pin 2		DB-25 pin: 23	PB0
pin 3		22	PB1
pin 4		21	PB2
pin 5		20	PB3
pin 6		19	PB4
pin 7		18	PB5
pin 8		17	PB6
pin 9		16	PB7
pin 10		power supply GND	IC ground
	pin 11	SB14	PB7
	pin 12	SB15	PB6
	pin 13	SB16	PB5
	pin 14	SB17	PB4
	pin 15	SB18	PB3
	pin 16	SB19	PB2
	pin 17	SB20	PB1
	pin 18	SB21	PB0
pin 19		S2 toggle	enable to ground
pin 20		power supply +5V	IC V _{cc}
IC3: pin 1		IC4 pin 1	Direction control
pin 2		DB-25 pin: 24	PA2
pin 3		9	serial ant
pin 4		7	SP2
pin 5		6	CNT2
pin 6		5	SP1
pin 7		4	CNT1
pin 10		IC4 pin 10	IC ground
	pin 13	SB4	CNT1
	pin 14	SB5	SP1
	pin 15	SB6	CNT2
	pin 16	SB7	SP2
	pin 17	SB11	serial ant
	pin 18	SB10	PA2
pin 19		IC4 pin 19	enable to ground
pin 20		IC4 pin 20	IC V _{cc}
IC2: pin 8		IC3 pin 10	IC ground
	pin 11	SB8	PC2
pin 12		DB-25 pin 8	PC2
	pin 13	DB-25 pin 15	FLAG2
pin 14		SB8	FLAG2
pin 15		IC3 pin 19	enable to ground
pin 16		IC3 pin 20	IC V _{cc}
		From	To
		DB-25 pin 3	SB3 RESET
		DB-25 pin 10	SB12 +9V
		DB-25 pins 1, 14, 25	power supply GND computer ground pins
		power supply GND	S2 enable
		power supply GND	S1 direction control
		power supply GND	SB22 ground
		+5V from R1	S2 direction control
		power supply +5V	SB2 interface +5-volt power
		S1 toggle	SB1 direction control

Note: SBn = solderless terminal block; n = the assigned number of the block.

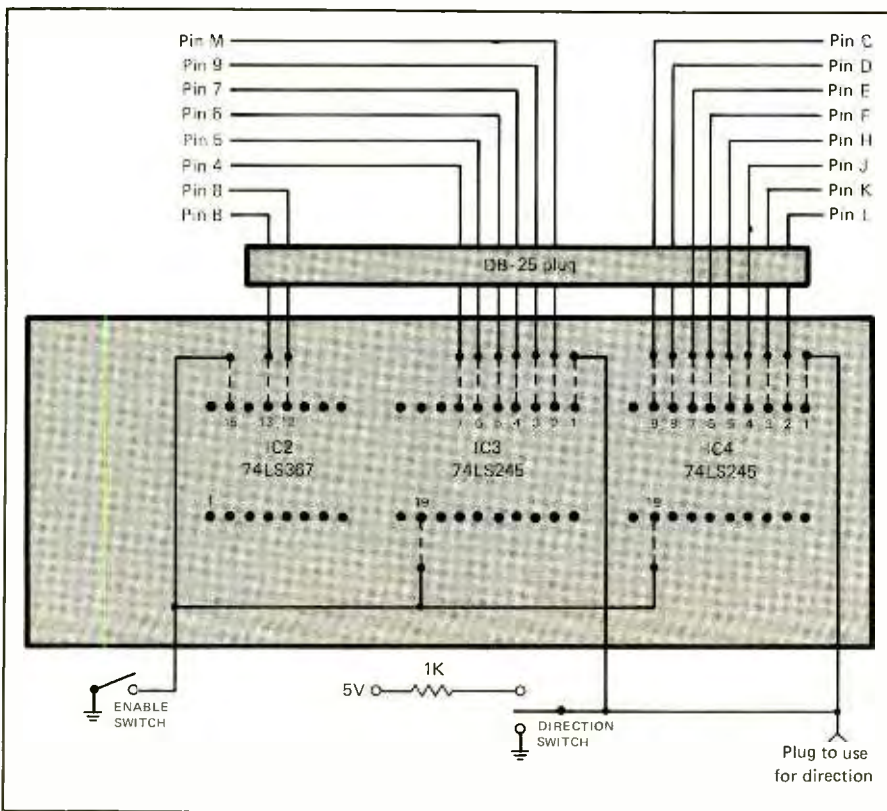

Fig. 5. Illustrated are details for wiring switches into circuit and interconnections between main board and DB-25 connector to edge connector.

Wrap the wires around the socket pins with a Wire Wrap tool. It's a good idea to wrap all wires to the input pins of the IC sockets and then tackle the soldering at the DB-25 connector end.

Use red Kynar wire to connect between the output pins of the IC sockets and the solderless terminal blocks on the top of the box. Strip $\frac{1}{4}$ " of insulation from one end of each of these wires but leave the other ends as they are. Wire Wrap the unprepared ends of these wires to the appropriate pins on the IC sockets (see Table II).

Feed the free ends of the wires up through the second row of holes in the perforated board, in line with the pins to which they're connected, just as you did for the input lines. The free ends of these wires will be connected to the lugs on the solderless terminal blocks later.

Wrap the red stranded wire com-

ing from the pad on the power supply module to which the top end of *R1* is connected around pin 20 of the *IC4* socket. Jumper a 3" red stranded wire from pin 20 of the *IC4* socket to pin 20 of the *IC3* socket and a second 3" red wire from pin 20 of the *IC3* socket to pin 16 of the *IC2* socket.

Wrap the free end of the black stranded wire coming from the right side of the ground bus in the power supply module to pin 10 of the *IC4* socket. Jumper a 3" black stranded wire from pin 10 of the *IC4* socket to pin 10 of the *IC3* socket and a second 3" black wire from pin 10 of the *IC3* socket to pin 8 of the *IC2* socket.

Carefully inspect all stranded-wire wrapped connections to make certain that they're connected to the appropriate pins on the sockets and that no wires are touching pins to which they shouldn't be connected. Then solder all wrapped connections. (See Figs.

2, 4 and 5 and Table II for all connection details.)

Strip $\frac{1}{4}$ " of insulation from one end of each of two 7" lengths of blue Kynar wire. Wrap the unprepared end of one of these wires around pin 1 of the *IC4* socket and connect and solder the other end to the center lug on *S1* (Fig. 5). Jumper a short blue Kynar wire from pin 1 of the *IC4* socket to pin 1 of the *IC3* socket. Wrap the unprepared end of the other 7" Kynar wire around pin 19 of the *IC4* socket and connect and solder the other end to either lug of *S2*. Jumper a short length of blue Kynar wire from pin 19 of the *IC4* socket to pin 19 of the *IC3* socket to pin 15 of the *IC2* socket.

Solder a 7" red stranded wire to one of the holes in the lower pad to which *R1* is connected in the power supply. Solder the end to one of the outer lugs on *S1*. Solder another 7" red stranded wire to the pad to which the jumpers from pin 2 of *IC1* and the top of *R1* connect. The other end of this wire will be connected later.

Trim away $\frac{1}{4}$ " of insulation from both ends of each of six 7" black stranded wires. Twist together the fine wires at each end and tin with solder. Insert one end of each of these wires into a free hole in the ground bus in the power supply module and solder. This done, solder the free ends of three of these wires to pins 1, 14 and 25 of the DB-25 connector. (Don't forget to route these wires through the slot.) Solder another of these wires to the other outer lug of *S1* and yet another to the lug of *S2* to which nothing is connected. The remaining wire will be connected later.

More To Come

Next month we will complete the construction details and tell you how to fabricate the cable and test the project.