

# RS232/DB9

## An RS232 to TTL Level Converter

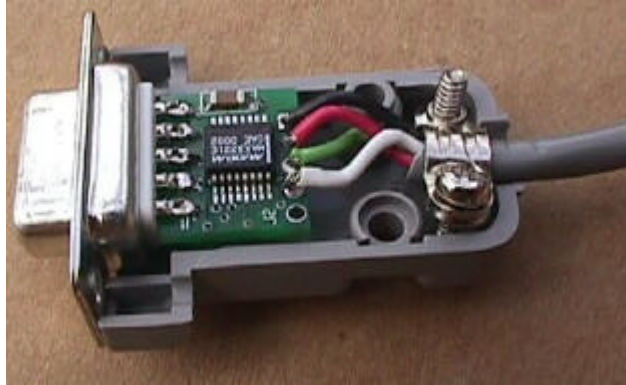

The RS232/DB9 is designed to convert TTL level signals into RS232 level signals. This cable allows you to connect a TTL level device, such as the serial port on a Micro-controller, to the serial port of a personal computer. The conversion circuit is housed inside the DB9 connector shell. Power is supplied from the Micro-controller board.

The board is based on the Maxim MAX3221CAE interface chip. This chip draws a mere 1 $\mu$ A of current when there are no RS-232 signals connected to the part.

With the exception of the DB9 connector and the wire, all parts on this board are surface mounted, and require care during assembly. The mounting of surface mount parts is not difficult, but does require a steady hand. A magnifying glass or other visual aid may be helpful. You also need some electronic paste flux.

### **Assembly Instructions for the RS232/TTL kit (DB9 version)**

- Apply Paste flux the pads for J1 (the DB9 connector).
- Insert board between the solder cups of the DB9 connector. One side of the connector has 5 pins and the other has four. Make sure the board is oriented correctly so there is a pad under each solder cup. Check the alignment and depth. Make sure there is a small amount of the solder pads extending beyond the solder cup, and that the solder cups align with the solder pads.
- To solder, I suggest using a fine tipped soldering iron. Clean the tip of any oxidation or solder by using a wet sponge and your solder flux or tip cleaner. The iron should be 'dry', which means as little solder as possible on the tip (none is best!).
- For the first two cups, I suggest soldering pad 6, 8, and 9, which are on the backside and farthest away from the small traces.
- To solder the cups to the solder pads, you want to heat both the pad and the solder cup on the DB9 at the same time. Place the solder iron on the little bit of exposed pad and touching the solder cup. The flux will help the solder flow up under the pad. You can add a small amount of solder while heating the pad by touching it to the solder pad.
- Pad 7 of the solder cup has a very short pad that really doesn't need to be soldered.
- Turn the connector board over. The pad in front of solder pads 4 and 5 need extra care, since you don't want to create a solder bridge there!
- Solder pads 1, 2, 3, 4, and 5 using the same technique used for the solder cups on the backside.
- Next we will attach the capacitors on the backside of the board. These are caps C1, C3, C4, and C5. Only cap C2 is on the 'TOP' side.

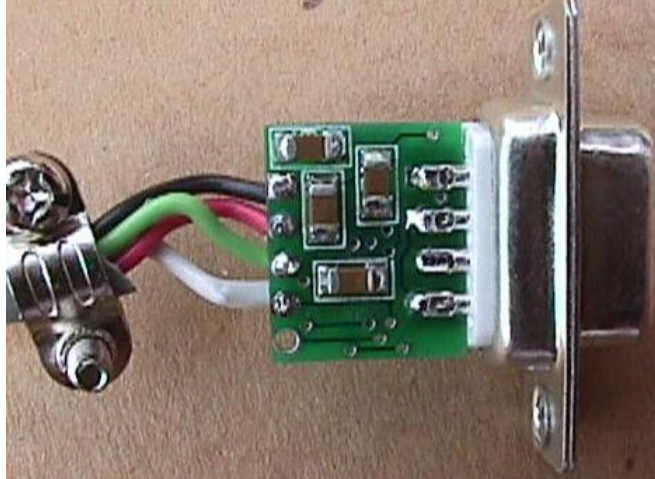

*The Bottom or Backside of the board showing the capacitors*

- These are ceramic chip capacitors. They are not polarized, so the direction they are mounted is not important. Take 1 capacitor at a time, and work carefully. I suggest following the order I use below, it appears to work best.
- Smear a thin coating of paste flux across the pads of the PCB. Don't worry if it gets on the fiberglass. I usually use a Q-Tip, and basically smear all of the pads on the board. Pickup C4 with a pair of tweezers or some other small tool. If you have nimble fingers, those work fine as well. Place it on the pads for C4. Note that the paste flux will help hold the part in place. If the part doesn't stick in the flux, you may need to add a little more.
- Remember that the trick to soldering surface mount parts is to use a dry solder iron to heat the solder that is already on the pads. Align C4 so it appears to be centered on its two solder pads. This should leave equal spaces around the chip on the pads. With C4 aligned on its pads, touch the tip of your soldering iron to the expose section of the solder pads and to the end of the capacitor. You will see the solder melt very quickly. Remove your iron, then move to the other side of the part and repeat. As a result, the part should be tacked down. Now that both sides are tacked, go back to each side and re-flow the solder slightly. This helps get you a solid connection.

On capacitors and resistors, I usually go back and add a very tiny amount of solder to the end of each pad. Heat the solder on the pad (the other side is already soldered and will keep it in place). Touch your solder to the part. See the picture below for the affect you are going for.

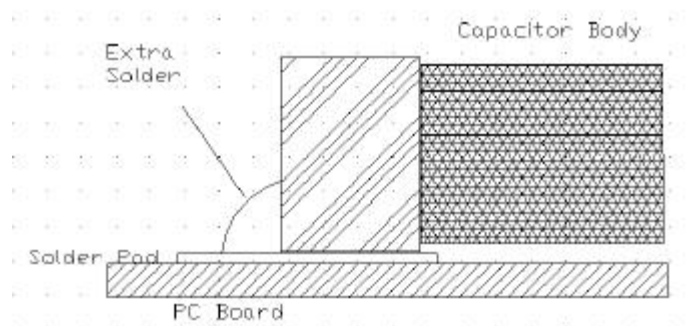

### **Extra Solder helps hold the part in place. Optional**

- Attach C1 next (back side)
- Attach C3 next (back side)
- Attach C5 next (back side)

- **STOP!**

- The next part to go on is the MAX3221 chip U1. **Don't put C2 on yet, as it will be in your way.** The MAX3221CAE is a 16-pin surface mount device. If you have it in your hand, you may notice that the chip is mighty small, with lots of little tiny pins! Please be careful with them as bending them out of alignment can cause extreme disaster! Alignment is critical on this part, and you should take your time to insure it is setup correctly. It isn't hard, but going fast can cost you a chip!

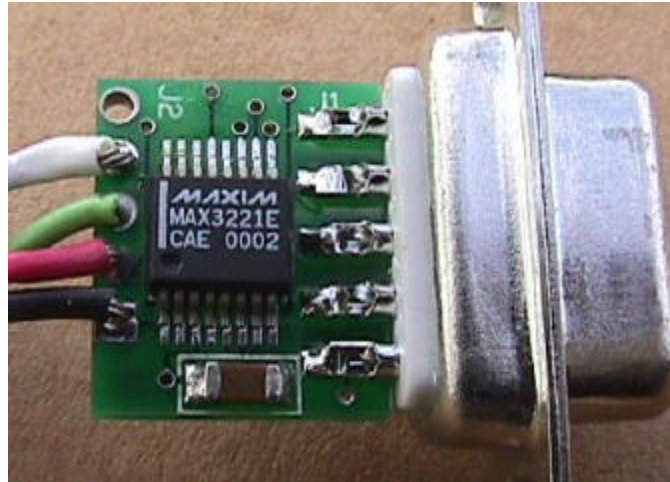

- To mount the chip, smear a coating of past flux to the top side of the board across the pads for U1. On the MAX3221CAE, pin 1 is marked with a small dot. Orient the part so that the small dot is aligned with PIN 1 as shown in the diagram. Note there are 2 axis to align to. You need to make sure the part is centered in both the X axis and Y axis on the board. There should be an equal amount of solder pad showing on both sides, and the pins should align squarely with the solder pads. A magnifying lamp or glass might be useful if you can't make out the individual pins.
- Using your solder iron, on PIN 1 ONLY, touch the iron, DRY and WITHOUT SOLDER to PIN 1 ONLY! You only need to heat it for a second or so. Remove your iron.
- Carefully recheck the alignment. Adjust so things are lined up, then touch the iron to the opposite corner (PIN 9 ONLY).
- Recheck the alignment and adjust by heating pins 1 or 9 as needed.
- Ok, now, recheck your alignment again! Once you start the next step, the chip is basically stuck on there, and you will need some luck and good tools to get it off.
- Carefully visit each pin with your solder iron, heating and re-flowing the solder that is already on the pad. DO NOT ADD MORE SOLDER TO THIS PART! It is tempting to do so, but you will get a solder bridge about 95% of the time.
- If your iron is dry, you can touch the pins to insure a good heating. 1 second is all that is required.
- Once all pins of the MAX3221 are attached, you can mount C2 just like the other capacitors.
- The last part soldered to the board is the cable. There are 5 wire pads with holes. Most people will only use 4 of them. The 5<sup>th</sup> pad is connected to the INVALID pin of the MAX3221. If you want to use it, then you should use a 5-conductor cable instead of a 4 conductor. I am assuming you are using a 4-conductor for these instructions.
- Pin 1 has the square pad.
- Strip about 1/2" to about 5/8" of the cables outer shell from the end of the cable. This should allow you enough room to work while leaving enough for the strain relief. If it is a little long (up to about 3/4"), you will be able to bend the wires slightly at the end to make them fit. From each individual wire, strip about 3/16" from the end. This is the wire that you will be inserting through the holes in the board.
- Insert all 4 wires at the same time, down from the top side of the board. I suggest pins 1 through 4 colored as Black (1), Red (2) Green (3) and White (4). If your cable has different colors, make a quick note of what color is wired to what hole. If you find it difficult to get the wire into the hole, you may

need to cut 1 or 2 of the little strands away flush with the insulation. This will make the wire fit into the .042" holes easier.

- Solder on the backside. Be careful not to damage or solder bridge the capacitors on the back.
- On the opposite end of the cable, attach the connector of your choice. BotBoards and the 68HC12 boards available from Kevin Ross all use the same 4 pin Molex KK series connector. Be sure to keep the coloring straight! (Black - 1 == GND, Red - 2 == +5v, Green - 3 == TX, White - 4 == RX)
- Attach the strain relief bracket around the outer cable near the end that you stripped off.
- Place the connector in one half of the DB9 shell. Insert the DB9 connection screws. Add the second half of the shell, and bolt together.

### ***Testing the Cable***

Assuming everything went well, your cable should now be ready for use. If you have purchased this along with a BotBoard Plus kit, then you should be able to download code to the BotBoard Plus using either dl11.exe on the BotBoard Plus diskette, or with PCBUG11.

## **Parts List**

Parts List for DB9 based RS-232/TTL Level Shifter	
<b>Part</b>	<b>Description</b>
J1	DB-9 Female Solder Cup Connector
J2	Wire holes - No part involved
U1	MAX3221CAE
C1,C2,C3 ,C4,C5	.1uf 50volt Ceramic Chip capacitor in 1206 sized case
PCB	Custom Printed Circuit Board
WIRE	4 conductor 22 gauge cable
1	DB9 Shell

PIN 5 OF J2 IS AN OPTIONAL CONNECTION. ITS OUTPUT INDICATES WHETHER A VALID RS-232 SIGNAL EXISTS ON J1.

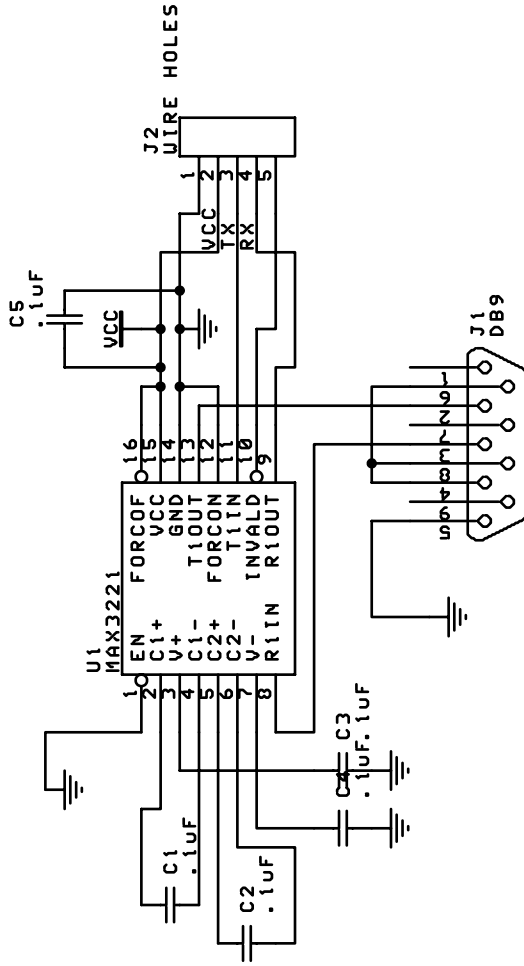

Title		DB9 based RS232/TTL converter designed to fit into DB9 shell.	
Copyright(c)		1999 Kevin U Ross	
Size	Number	Revision	
A	DB9CON.501		1.0
Date:	15-FEB-1999	Sheet	1 of 1
File:	C:\PROTEL\SCHMATIC	Drawn	BY: