

CAD FILE:

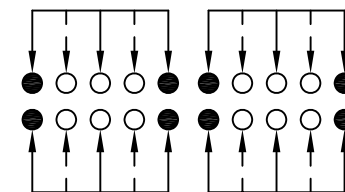

SCHEMATIC (SHORTING)

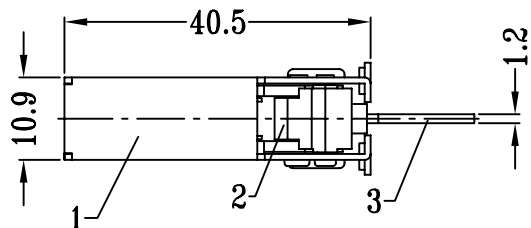
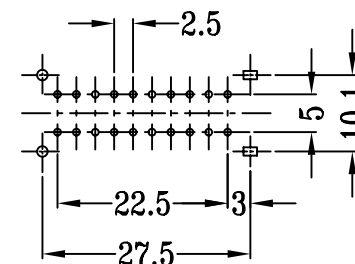
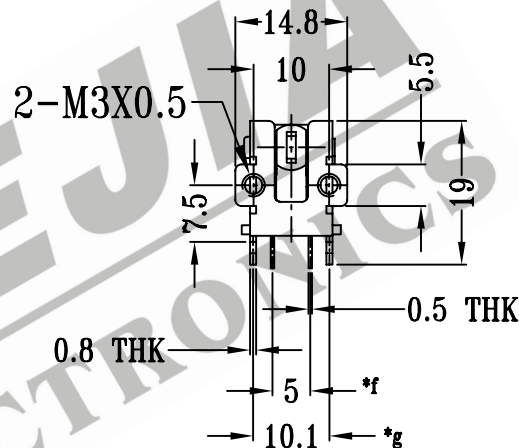
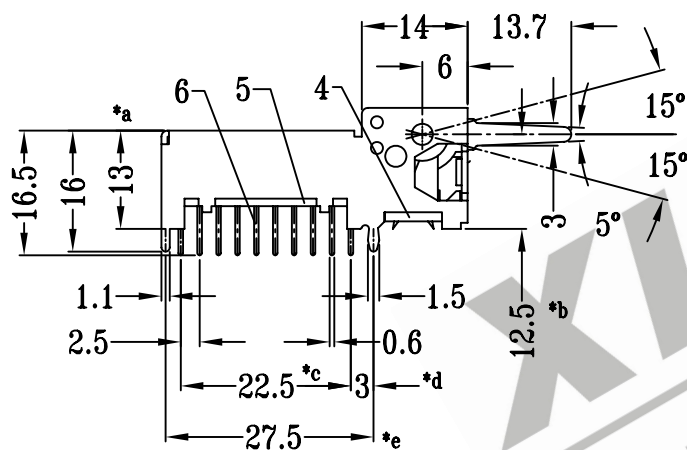

P.C.B LAYOUT

11	CONTACT(CLIP)	PBS	4	Ag CLAD
10	SLIDER	POM	1	BLACK
9	SPRING	STEEL WIRE	1	TEMPER
8	RIVET	COPPER	2	Ni PLATED
7	STEEL BALL	STEEL	1	NATURAL
6	TERMINAL	BRASS STRIP	20	Ag PLATED OVER Ni PLATED
5	BASE	PHENOLIC RESIN	1	NATURAL
4	POSITION PLATE	POM	1	BLACK
3	STEEL KNOB	STEEL STRIP	1	Ni PLATED
2	KNOB	POM	1	BLACK
1	FRAME	STEEL STRIP	1	Ni PLATED
NO.	PART NAME	MATERIAL	Q'TY	FINISHING

TOLERANCE UNLESS SPECIFIED		SHENZHEN XIEJIA ELECTRONICS CO.,LTD.			
WITHIN: 1.5±0.1mm		ISSUE	DATE	DESCRIPTIONS	APPD.
OVER : 1.5±0.2mm					
TITLE : TOGGLE SWITCH			UNIT : MM	DRWG NO.: XJ-DR-LS43E11-00	
MODEL: LS-43E11			SCALE: 1 : 1	DWN. ZHOUYU	2001-12-13
ALL MATERIALS MUST BE COMPLIANT TO ROHS				CHK'D FANGYING	2001-12-13
				APPD. KANGXINAN	2001-12-13

注:带"*"表示关键尺寸(7个)