

GAS MONITOR

ETI Project Team present a machine which nose when you're fuming, and which can be suitably alarming. Particularly useful to boat owners, and of value to all needing to keep an eye on the gases.

PETROL VAPOUR, closed space and electrical sparks are not ideal companions. Many a boat has been destroyed when the owner has switched on the ignition without realising there had been a petrol leak and the vapour content in the engine compartment is at a dangerous level. Unfortunately the circumstances also lead to injury and loss of life. Therefore any system which can prevent this is of great value.

This unit is designed to meet this requirement and uses a semiconductor gas detector (TGS cell) to monitor the atmosphere in the engine compartment and either prevent the engine being started or shut it down if a high vapour concentration occurs during operation.

Construction

This is relatively easy if the printed circuit board is used and the wiring diagrams are followed. Some precautions should be taken if the unit is to be used in a boat to prevent corrosion. The rear side of the board should be coated with a cellulose spray (dope, nail polish, etc.) and the box, while having to be near the control panel, should be shielded from direct spray. Although we have used a separate box the unit can be mounted behind the control panel if desired.

A small heatsink (about 25 mm square aluminium) should be bolted on to IC1 to keep it cool.

The relay should be capable of handling up to 5A and should have a 12V coil with a resistance of over 100 ohms.

Obviously the sensor must be mounted in the engine compartment and while it must be in free air it must also be protected against mechanical damage.

Installation and Adjustment

The sensor should be mounted in a position where vapour may be expected and should be mechanically protected against damage. The

connection to the sensor should be via a four core cable (on long runs use a shielded cable).

Note that the sensor is symmetrical in layout and also the fact that it will fit into a standard seven pin miniature valve socket.



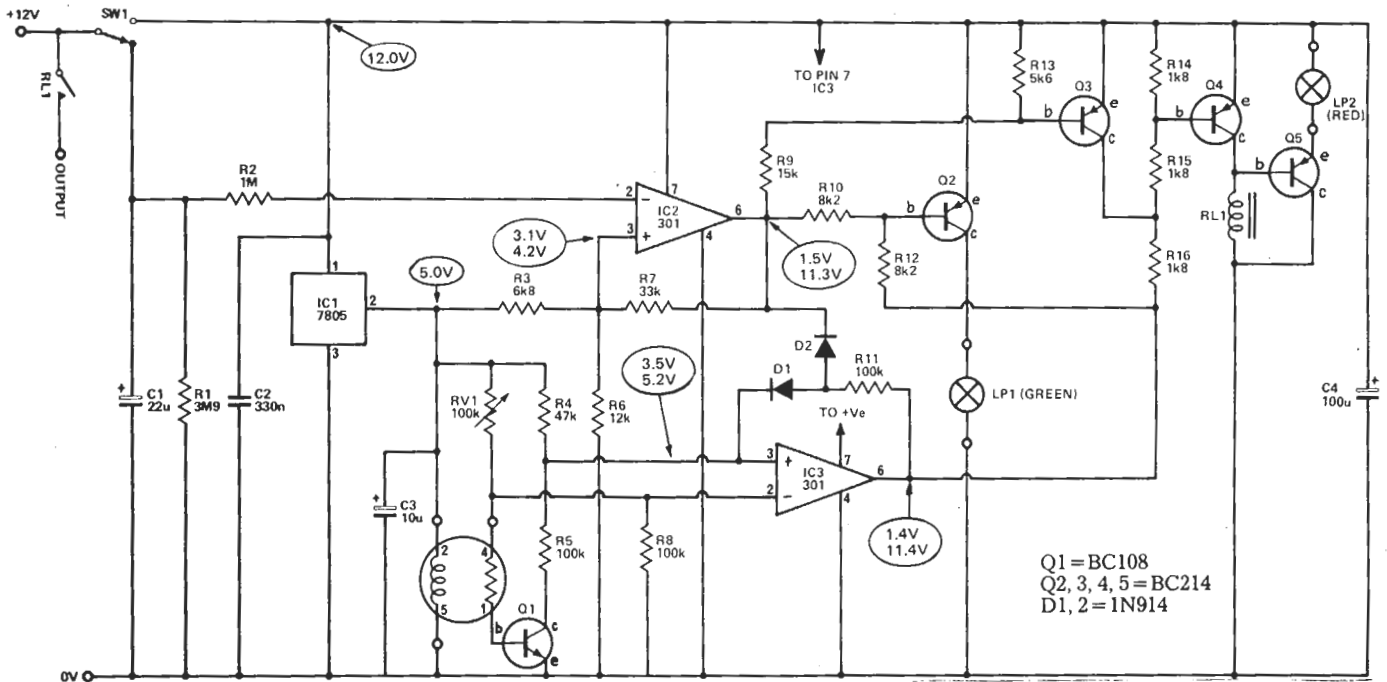

Fig 1. Full circuit diagram of the marine gas alarm.

HOW IT WORKS

This project is designed primarily to monitor the concentration of volatile gases inside the bilge of petrol-engined boats. The circuit provides an electrical cutout which prevents the engine from being started if fumes are present and also will remove all electrical power if fumes become present at any time.

The unit acts as a master switch and due to its warm up requirements, a two minute delay occurs on switch on. Two indicator lights indicate either "safe" or "fail" condition and in the initial warm up period both lights are on. The initial timing is performed by C1 and IC2. With the main switch off there is +12 V across C1. When it is switched on the

capacitor is allowed to discharge through R1. IC2 compares the voltage on C1 with that on pin 3 (about 3 V). During this period the output of IC2 will be about +2 V.

IC1 is a 5 V regulator and supplies the power for the heater of the sensor. The sensor's resistant element is in series with RV1 and this voltage is compared to the voltage set by R4/R5.

The transistor Q1 gives a fail safe operation and if the sensor is not connected this transistor will be off giving +5 V on pin 3 of IC3. Resistor R8 ensures that the voltage on pin 2 will always be slightly less than +5 V.

If vapour is present the sensor resistance will be low and the output of IC3 will be high. During the first two minutes the diodes D1 and D2 prevent the feedback loop (R11) operating. After two minutes if the output goes high the reference voltage on pin 3 of IC3 will go above 5 V and therefore the IC will latch in that position.

The relay is operated by Q4 and for it to close the output of IC3 must be low (no vapour) and also the output of IC2 must be high (more than two minutes after switch on). If the unit does switch off, or prevents initial switch on, it must be switched off and then on again (after clearing the fumes) and the two minute delay operates again.

The only adjustment is the sensitivity control and this is set by bringing a small container of petrol near the sensor and ensuring it operates. The adjustment should be as sensitive as possible without giving false operation.

Other Applications

By suitable choice of sensor from the TGS range (see data sheet this issue) the basic electronics, with perhaps a few modifications, can be used for a number of other applications — for example switching on an extractor fan if the carbon monoxide level in a garage reaches a dangerous level. No doubt numerous other applications for this project will occur to you.

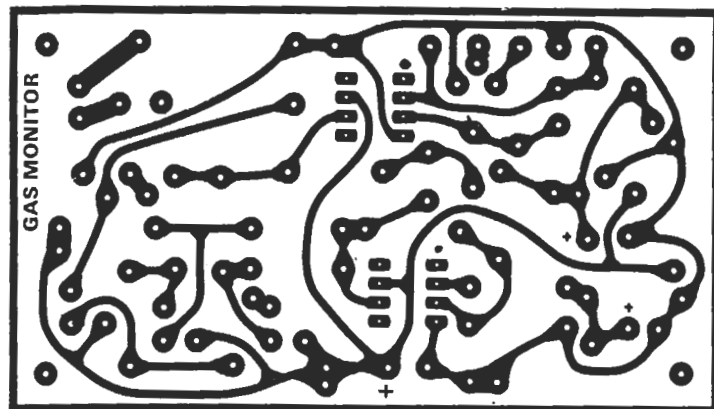

Fig 2. PCB pattern foil side shown full size (52 x 92 mm).

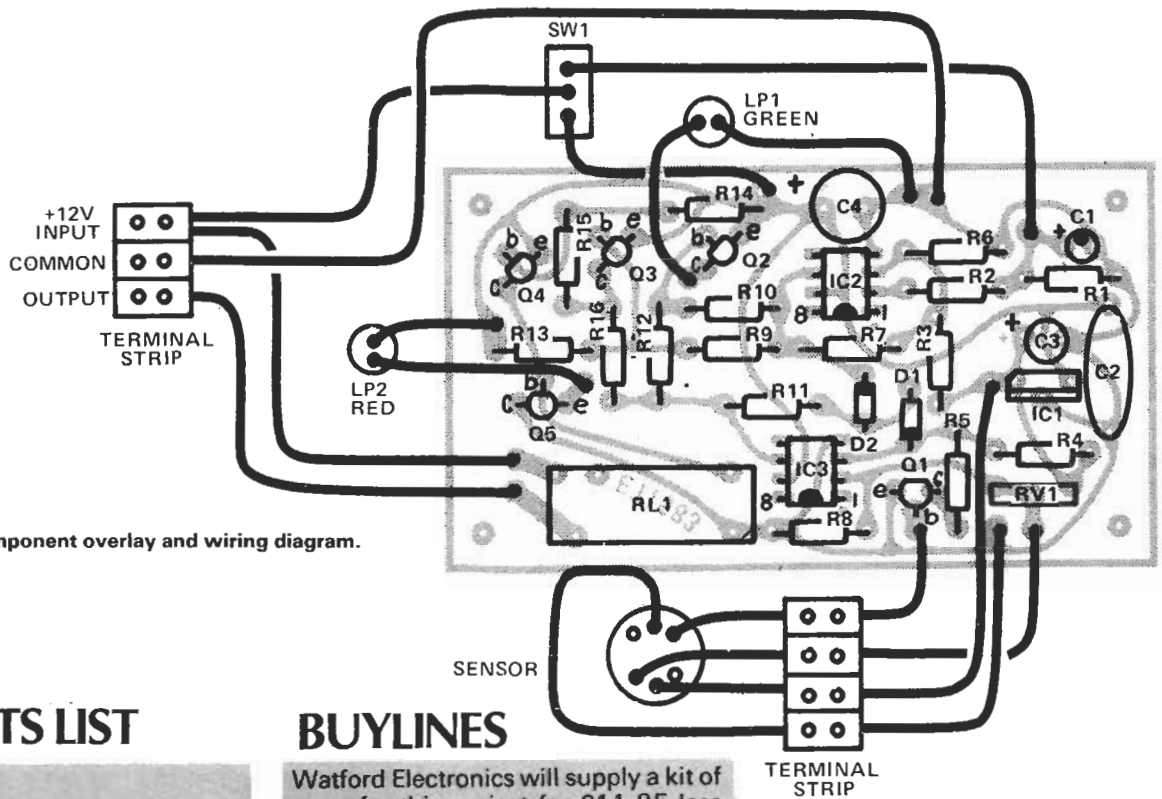

Fig 3. Project component overlay and wiring diagram.

PARTS LIST

RESISTORS

R1	3M9
R2	1M
R3	6k8
R4	47k
R5,8,11	100k
R6	12k
R7	33k
R9	15k
R10,12	8k2
R13	5k6
R14,15,16	1k8

POTENTIOMETERS

RV1	100k vert. preset
-----	-------------------

CAPACITORS

C1	22u 16V Tantalum
C2	330n Polyester
C3	10u 16V Electrolytic
C4	100u 25V Electrolytic

SEMICONDUCTORS

IC1	7805
IC2,3	LM301A
Q1	BC548
Q2,3,4,5	BC214

SENSOR

TGS	812 or 813
-----	------------

LAMPS

LP1,2	12V 100mA
-------	-----------

MISCELLANEOUS

Relay to suit application (min res 100R),
PCB as pattern, box etc.

BUYLINES

Watford Electronics will supply a kit of parts for this project for £11.95 less box which should be selected to suit the constructor's particular application, i.e. the expense of a die cast box would not be warranted unless the device needs to be waterproof.

Watford will also supply all parts separately, e.g. the sensor plus holder.

