

# Teleflex® 301

# Autopilot

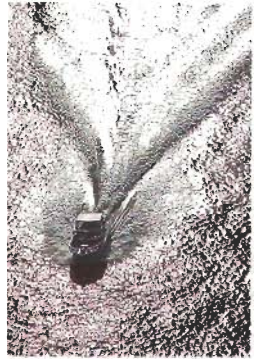

# Reliable, Precise Performance



## Features:

### Control Unit:

- Simple, user friendly keypad operation
- Rotary course change knob
- Waterproof
- Flush or bracket mounting

### Operation:

- Unsurpassed course keeping
- Two pre-sets for fast or slow operation
- Automatic course acquisition or pre-select
- Automatic trim
- Automatic self test
- Automatic switch to "ghost rudder" if reference is lost
- Current limiting

### Display:

- 8 character alpha numeric Displays
  - Compass Heading
  - Rudder Angle
  - Nav cross track error
  - Fault codes
- Backlit with adjustable light level

### Fluxgate Compass:

- Special high acceleration design for high speed or high seas
- Automatic compass deviation correction
- Adjustable compass damping
- Output to navigator

### Navigator Interface:

- Completely integrated
- Adaptable to full range of NMEA 0180 to 0183 codes



### Installation/Set Up:

- Fully programmable control system
- Select pre-sets for different boat types
- Automatically loads fast/slow settings for selected boat types
- Simple connection system for all units including options
- Electronic rudder limits

### Alarms:

- Off course
- Loss of navigator input
- Low voltage
- Self test system fault codes

### Options:

- Full second station
- Dodge remote
- Power steering remote

### Drive Units:

- Quiet, efficient Hydraulic Power Packs
- Built in RF noise suppression
- Other options such as linear actuators

### Warranty:

- One year limited

# The Teleflex 301 Autopilot:

Cast off with confidence when you have the ultimate Autopilot course control system aboard. The Teleflex 301 is state-of-the-art, yet simple to operate and price competitive.

The Teleflex 301 will greatly increase the pleasure of boating by relieving you of the tedious chore of steering a course over long runs. Your hands are left free to tend fishing lines or you can simply sit at the helm, observe the way ahead and enjoy the ride. With a navigator attached the system can take you automatically to your destination, directly or via a series of waypoints.

You can relax knowing that the Teleflex 301 Autopilot is a leader in safety and reliability.

Designed for all power boats in the 30 to 75 foot range, the Teleflex 301

features a state-of-the-art electro-hydraulic system, a powerful microprocessor and the most recent compass technology. You will enjoy a fully pre-programmed operation while still maintaining the security of being able to use manual adjustments when desired.

A full range of additional features are included with the Teleflex 301. A multi-function display, fully adaptable navigator interface, automatic compass deviation correction, automatic self test and alarm system and dual station capability are all standard features.

Teleflex is North America's leading supplier of marine control systems. We are unsurpassed in our commitment to innovation, quality and customer support.

Our years of research and experience in marine systems including

mechanical steering, engine controls, instruments and hydraulic steering have led us to the development of the Teleflex 301 Autopilot, the last word in course control and true simplicity of operation.

## Operation

Holding your boat on course has never been so easy. With the Teleflex 301, all you do is press the "Autopilot" key. The system takes over and steers you along your existing course.

Heading adjustments are made by simply turning the rotary knob, in effect giving you the ability to steer with your fingertips.

You can also pre-select an exact course by using the rotary knob and the digital display.

All keypad controls do exactly what their labels say; there are no confusing,



# Powerful Microprocessor Control, Si

hidden functions. Even switching in and out of navigator control requires only single key strokes.

A convenient "Display" key can be used at any time to select displays for heading, rudder angle or navigator cross track error.

A second keyboard console can be fitted to give full control at two locations. Hand-held remotes for dodge/course change or power steering are also available.

## Pre-set Control

The Teleflex 301 introduces a new concept in ease of operation.

A simple key stroke allows you to select the setup for fast or slow speed. No performance and time are lost while attempting to adjust the full system manually or automatically to changing conditions. The optimum settings are loaded instantly from memory.



There is no simpler way to maintain true optimum course keeping at full speed, when trolling or slowing down in rough weather.

If you prefer to adjust the system manually, rudder gain and system response are easily accessed by a second touch of the "Adjust" key. Trim, or standing rudder, is adjusted automatically.

## Installation

We have designed ease of installation into the Teleflex 301 Autopilot. Our 30 years experience in marine steering systems combined with a simple plug-in wiring system, automatic compass deviation correction and our unique new pre-programmed system set-ups have significantly simplified installation.

The high degree of sophistication of this autopilot provides a considerable number of adjustable parameters for adapting to specific boats. Performance has not been sacrificed by reducing available adjustments to simplify or fully automate the system.

In order to streamline the installation setup procedure while retaining system power and flexibility we have pre-programmed an entire range of boat data. Eight different adjustments for two speed ranges are set by simply selecting your boat type during installation.

These pre-sets can also be adjusted for special boat types while retaining the simple operating procedure.

## Safety

The Teleflex 301 has been designed to the most exacting safety standards. Quality and reliability are built into the entire system.

The Teleflex 301 system constantly monitors itself and displays an alarm to help alert you if you're off course, if navigator data is lost, or if voltage is low. If problems are detected in individual components, it will also signal automatically with a variety of fault codes. The Teleflex 301 even switches control auto-

matically to "ghost rudder" to get you home safely if rudder feedback is lost. In an emergency, a push of the separately wired "Power Off" key returns you to manual steering no matter what the status of the microprocessor.

## Navigator Interface

Standard with the Teleflex 301, is an interface that is fully adaptable to the full range of NMEA 0180 to 0183 formats used in Loran and Satnav systems. No additional boxes are required, the interface is built in.

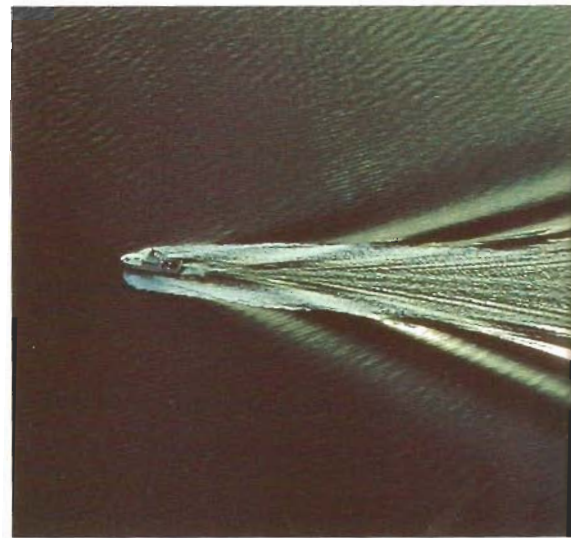

## Fluxgate Compass

A key component in the Teleflex 301 system, the Fluxgate compass, is the latest development from the leader in this technology. It was created specifically for the demands of the Teleflex 301 Autopilot system. Only this type of compass can handle the rough motion of high speed boats or heavy sea conditions while constantly producing accurate heading information. It can even send heading data to your navigation system.

## Drive Systems

The Teleflex 301 gives you a full range of drive options including our new line of hydraulic power packs. Our hydraulic steering designers have used their extensive experience in this area to create significant advances in performance and ease of installation.

# mplicity of Operation

## Keyboard Console

Ease of operation with no sacrifice in system performance or flexibility.

**STANDBY  
On**

Engages "Standby" mode. The operator retains manual steering but the display indicates that the Auto-pilot is ready to take over.

HEAD 068

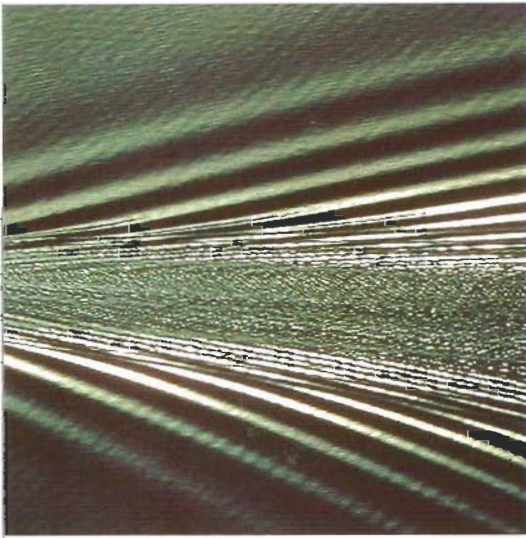

**AUTO  
PILOT**

Engages "Autopilot" control on the present indicated heading. The display changes to show the set course.

AUTO 068

**NAV  
PILOT**

Transfers control to a "Navigation System" which is transmitting data to the Autopilot. The display will indicate course to waypoint.

NAV 290

**DISPLAY  
Set**

Select alternate displays at any time such as Rudder Angle.

RUDDER ANGLE 12.5

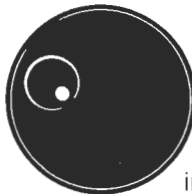

"Course Changes"

in Autopilot mode or allows "Course To Steer" to be pre selected before engaging Autopilot. Display shows new course selected until adjustment complete.

CTS 340

**ADJUST  
SELECT**

Select Fast or Slow boat speed presets via a single push. Further adjustments are normally not required.

SET FAST

Additional keystrokes provide the option, when desired, of adjustments to available manual controls or the pre-sets.

GAIN --- 12



# Teleflex 301

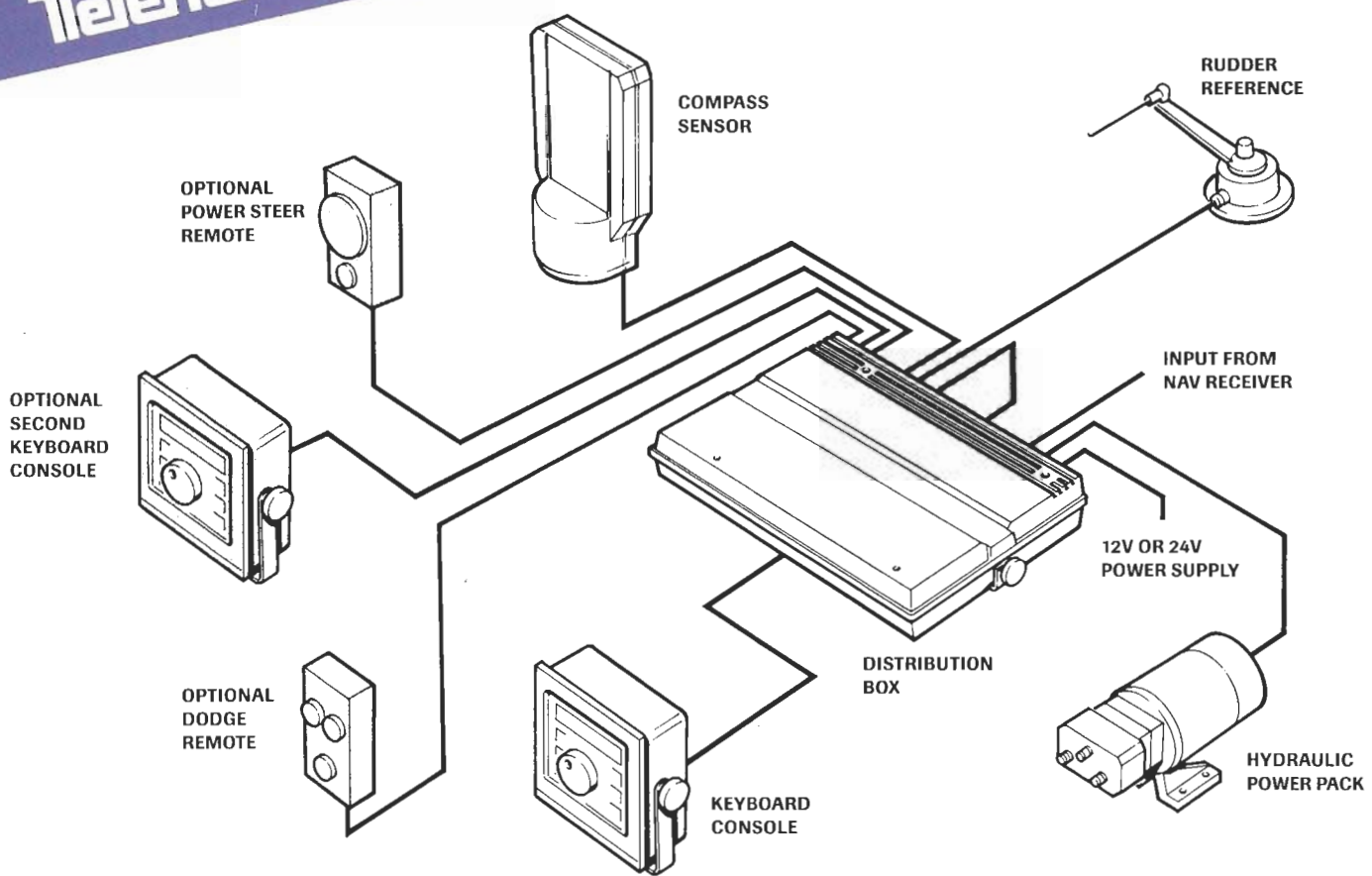

## Part Numbers for Ordering

### Basic System Components:

Model:	Description:
AP2577	Compass
AP2618	Distribution Box
AP2727	Keyboard Console
AP2807	Rudder Reference
See chart*	Power Pack

### Optional Components:

Model:	Description:
AP2727	Second Keyboard Console
AP2717	Remote—Power Steer
AP2797	Remote—Dodge & Course Change

All components include a minimum of 10' (3M) of cable. Miscellaneous hardware not included.

## Power Packs for Boats with Hydraulic Steering\*

Planing		Displacement	
Cylinder Volume Range	Cylinder Volume Range	Voltage	Model
7–13 in <sup>3</sup>	7–19 in <sup>3</sup>	12V	AP0110
115–210cc	115–310cc	24V	AP0210
13–19 in <sup>3</sup>	13–29 in <sup>3</sup>	12V	AP0116
210–310cc	210–475cc	24V	AP0216
19–31 in <sup>3</sup>	19–41 in <sup>3</sup>	12V	AP2102
310–508cc	310–675cc	24V	AP2112

This is a guide only. Actuators are available for other types of steering. Contact your Teleflex Autopilot Dealer for details.

