



WINDSCREEN WIPER CONTROL



THIS device, which can only be used with those windscreen wiper motors having a self-parking system since the system serves to turn-off the thyristor, can provide sweep delays of from 2 to 35 seconds.

The circuit is very simple, see Fig. 1, and uses few components. The original was constructed in a 35mm film can with switch S1 mounted on the variable resistor VR1. The control transistor is a UT46 or equivalent (2N2646) and the thyristor uses the can as a heatsink.

If the vehicle is negative earth with the windscreen wiper motor switched in the earth lead then the can may be earthed and only two leads are needed. One for positive supply and one for the positive supply to the wiper motor. As the thyristor is in parallel with the wiper motor polarity must be observed with care or triggering will not occur.

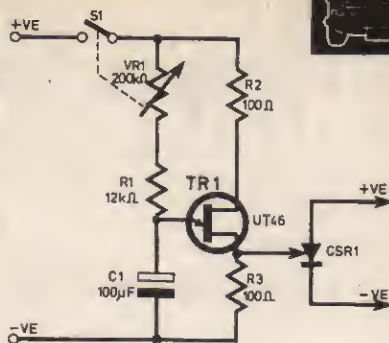

Fig. 1. Windscreen wiper delay circuit

The thyristor should be a high p.i.v. version, in the original a 7A 50V p.i.v. type was used.

C. M. Calver,
Melton Mowbray

ENGINE TEMPERATURE CONTROLLER

The circuit of Fig. 1 includes a stabiliser section, TR1, R1, R3, C1 and D1. This supplies power for the remainder which is basically a Wheatstone bridge circuit in which the thermistor TH1 forms one arm.

Balance of the bridge determines when the transistor TR2 cuts off. The vehicle fan is switched by RLA1.

For operation the normal "Temperature High" warning indicator is replaced with a thermistor. In practice the circuit is fail safe in that if TR2 goes open circuit for any reason then the fan is automatically switched on.

When the engine is cool the thermistor has a high resistance which puts TR2 in the ON condition. As temperature increases and resistance decreases the bias voltage across the transistor decreases until TR1 cuts OFF. The level of cut-off is determined by VR1. The value of R3 is determined by measuring the bridge circuit resistance and making R3 equal it. R1 may need adjusting if R3 is high.

Manual over-ride and a form of test facility may be provided by replacing the link by a switch.

If required a temperature indicator can be added as shown in Fig. 2. The voltmeter must have a high resistance with respect to R2. The 6 volt Zener is used to hold the zero down by 6 volts. In practice the "normal" temperature will probably show as about 1 volt.

R. K. Todd,
Albrighton

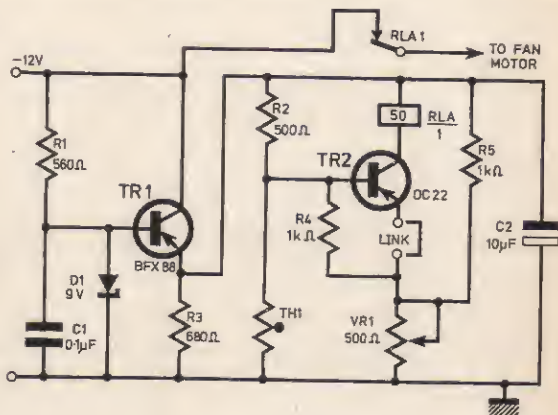
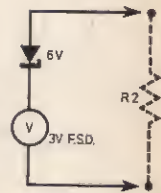

Fig. 1. Circuit for the temperature controller

Fig. 2. Adding a temperature gauge



BRAKE LIGHT MONITOR

INDICATION of the state of the brake lights on a vehicle may be obtained without inserting extra lamp bulbs in the brake light circuit by using a reed switch actuated by a specially wound double coil to actuate a panel indicator lamp.

The circuit shown in Fig. 1 indicates the simplicity of the idea. Two coils serve to actuate the one reed but they are counter-wound so that as long as the pair of brake lights operate the reed remains quiescent. If

one or other bulb fails then the reed is operated to give an indication at the dash board.

S. W. F. Morum
Chislehurst

Fig. 1. Brake light monitor

