



**MU-110 VERSION**

**INSTALLATION HAND BOOK**

**INSTITUTIONAL  
COMMUNICATION  
SYSTEM**

**IC-100**

Please follow the instructions in this manual to obtain the optimum results from this system.  
We also recommend that you keep this manual handy for future reference.

**TOA Corporation**

## FCC REQUIREMENTS

- (1) This equipment complies with Part 68 of the FCC rules. On the front panel of this equipment is a label that contains, among other information, the FCC registration number and ringer equivalence number (REN) for this equipment. If requested this information must be provided to the telephone company.
- (2)

USOC Jack	RJII Cor RJIIW
Service Order Code	9.OF
Facility Interface Code	02LS2
- (3) The REN is used to determine the quantity of devices which may be connected to the telephone line. Excessive REN's on the telephone line may result in the devices not ringing in response to an incoming call. In most, but not all areas, the sum of the REN's should not exceed five (5.0). To be certain of the number of devices that may be connected to the line, as determined by the total REN's contact the telephone company to determine the maximum REN for the calling area.
- (4) If the terminal equipment IC-100 causes harm to the telephone network, the telephone company will notify you in advance. But if advance notice is not practical, the telephone company will notify the customer as soon as possible. Also, you will be advised of your right to file a complaint with the FCC if you believe it is necessary.
- (5) The telephone company may make changes in it's facilities, equipment, operations, or procedures that could affect the operation of the equipment. If this happens, the telephone company will provide advance notice in order for you to make the necessary modifications in order to maintain uninterrupted service.
- (6) If trouble is experienced with this equipment IC-100, please contact TOA Electronics, Inc., 601 Gateway Boulevard, Suite 300, South San Francisco, CA. 94080, Phone (41 5) 588-2538 for repair and warranty information. If the trouble is causing harm to the telephone network, the telephone company may request you remove the equipment from the network until the problem is resolved.
- (7) This equipment may not be used on coin service provided by the telephone company. Connection to party lines is subject to state tariffs.
- (8) This equipment is hearing aid compatible.

## DOC NOTICE 1.

**“NOTICE:** The Canadian Department of Communications label identifies certified equipment. This certification means that the equipment meets certain telecommunications networks protective, operational and safety requirements. The Department does not guarantee the equipment will operate to the user's satisfaction.

Before installing this equipment, users should ensure that it is permissible to be connected to the facilities of the local telecommunications company. The equipment must also be installed using an acceptable method of connection. In some cases, the company's inside wiring associated with a single line individual service may be extended by means of a certified connector assembly (telephone extension cord). The customer should be aware that compliance with the above conditions may not prevent degradation of service in some situations.

Repairs to certified equipment should be made by an authorized Canadian maintenance facility designated by the supplier. Any repairs or alterations made by the user to this equipment, or equipment malfunctions, may give the telecommunications company cause to request the user to disconnect the equipment.

Users should ensure for their own protection that the electrical ground connections of the power utility, telephone lines and internal metallic water pipe system, if present, are connected together. This precaution may be particularly important in rural areas.

**Caution** : Users should not attempt to make such connections themselves, but should contact the appropriate electric inspection authority, or electrician, as appropriate.”

## **DOC NOTICE 2.**

“The Load Number (88) assigned to each terminal device denotes the percentage of the total load to be connected to a telephone loop which is used by the device, to prevent overloading. The termination on a loop may consist of any combination of devices subject only to the requirement that the total of the Load Numbers of all the devices does not exceed 100.”

## **DOC AVIS 1.**

“**AVIS** : –L’étiquette du ministère des Communications du Canada identifie le matériel homologué. Cette étiquette certifie que le matériel est conforme à certaines normes de protection, d’exploitation et de sécurité des réseaux de télécommunications. Le Ministère n’assure toutefois pas que le matériel fonctionnera à la satisfaction de l’utilisateur.

Avant d’installer ce matériel, l’utilisateur doit s’assurer qu’il est permis de le raccorder aux installations de l’entreprise locale de télécommunication. Le matériel doit également être installé en suivant une méthode acceptée de raccordement. Dans certains cas, les fils intérieurs de l’entreprise utilisés pour un service individuel à ligne unique peuvent être prolongés au moyen d’un dispositif homologué de raccordement (cordon prolongateur téléphonique interne). L’abonné ne doit pas oublier qu’il est possible que la conformité aux conditions énoncées ci-dessus n’empêchent pas la dégradation du service dans certaines situations. Actuellement, les entreprises de télécommunication ne permettent pas que l’on raccorde leur matériel à des jacks d’abonné, sauf dans les cas précis prévus par les tarifs particuliers de ces entreprises.

Les réparations de matériel homologué doivent être effectuées par un centre d’entretien canadien autorisé désigné par le fournisseur. La compagnie de télécommunications peut demander à l’utilisateur de débrancher un appareil à la suite de réparations ou de modifications effectuées par l’utilisateur ou à cause de mauvais fonctionnement.

Pour sa propre protection, l’utilisateur doit s’assurer que tous les fils de mise à la terre de la source d’énergie électrique, des lignes téléphoniques et des canalisations d’eau métalliques, s’il y en a, sont raccordés ensemble. Cette précaution est particulièrement importante dans les régions rurales.

**Avertissement.** –L’utilisateur ne doit pas tenter de faire ces raccordements lui-même; il doit avoir recours à un service d’inspection des installations électriques, ou à un électricien, selon le cas.”

## **DOC AVIS 2.**

“L’indice de charge (88) assigné à chaque dispositif terminal indique, pour éviter toute surcharge, le pourcentage de la charge totale qui peut être raccordée à un circuit téléphonique bouclé utilisé par ce dispositif. La terminaison du circuit bouclé peut être constituée de n’importe quelle combinaison de dispositifs, pourvu que la somme des indices de charge de l’ensemble des dispositifs ne dépasse pas 100.”

**WARNING : (For U.S.A. only)**

This equipment generates, uses, and can radiate radio frequency energy and if not installed and used in accordance with the instructions manual, may cause interference to radio communications. It has been tested and found to comply with the limits for a Class A computing device pursuant to Subject J of Part 15 of FCC Rules, which are designed to provide reasonable protection such interference when operated in a commercial environment.

Operation of this equipment in a residential area is likely to cause interference in which case the user at his own expense will be required to take whatever measures may be required to correct the interference.

## CONTENTS

### PART. 1. GENERAL DESCRIPTION

1. <b>Outline and Features</b> .....	6
1.1 Outline	
1.2 Features	
2. <b>System Configuration and Module Functions</b>	
2.1 System Configuration .....	7
2.2 Module Functions .....	8-9

### PART. II. INSTALLATION

1. <b>Installation and Adjustment Procedure</b> .....	10
2. <b>Equipment Installation</b>	
2.1 Installation Precautions .....	10
2.2 CK-100 Card Case	
(1) Rack Mounting .....	11
(2) Wall Mounting .....	12
2.3 Power Supply	
(1) Rack Mounting .....	13
(2) Wall Mounting .....	14
2.4 Sub-Station	
(1) RS-100 Switch Panel .....	15
(2) RS-110 Sub-Station Handset .....	15
(3) RS-120 Sub-Station .....	16
(3.1) Flush-Mount Electrical Box	
(3.2) Dimensional Diagram	
(4) RS-130 Sub-Station .....	17
(4.1) Flush-Mount Electrical Box	
(4.2) Dimensional Diagram	
2.5 Control Stations	
(1) Installation	
(1.1) AS-100A Control Station .....	18
(1.2) AS-110 Control Station .....	19-20
(2) External Speaker Connection .....	21-22
(3) Speaker Volume and Microphone Sensitivity Adjustment .....	22
(4) External Microphone or Headset Connection .....	22-23

<b>3. Line Installation</b> .....	24
<b>4. Interconnection</b>	
4.1 Card Installation and Connection .....	24~25
4.2 MU-110 Main Control Card Connection	
(1) External Input and Output Controls .....	26
(1.1) Program Source Input .....	26
(1.2) External Microphone All-Call Paging .....	26
(1.3) External Time Signal Source Input .....	26
(1.4) PA Paging .....	26
(1.5) External Bell Control .....	26
(1.6) External Time Signal Trigger .....	27
(1.7) Master Clock Synchronization .....	27
(2) Input/Output Terminals .....	27
(3) Input/Output Terminal Connection Example .....	28
(4) Jumper Setting and Volume Adjustment .....	29
(5) Cable Connection .....	30
4.3 LU Card and Control Station/Sub-Station Connection	
(1) LU Card Number Setting .....	30
(2) LU Card Connection .....	31
(2.1) Cable Connection .....	31
(2.2) Control/Sub-station Connection .....	32
(3) Control Station Connection and Number Setting	
(3.1) AS-100A Control Station .....	33
(3.2) AS-110 Control Station .....	34
(3.3) Control Station Number Setting .....	34
(4) RS-100 Switch Panel and RS-110 Sub-Station Handset Connection	35
(5) RS-120/RS-130 Sub-Station Connection .....	36
(5.1) Connection to the LU-100 (For 25V Line)	
(5.2) RS-120/RS-130 Part Description	
(6) RS-102 Sub-Station Connection	
(6.1) When Not Using Sub-Station Handset (Room Station Handset) .....	37
(6.2) When Using Sub-Station Handset (Room Station Handset) .....	38
4.4 CT-100 C/O & Tie-Line Card Connection	
(1) Tie-Line interface Connection .....	39~40
(2) C/O Line and PBX Extension Connection .....	41
4.5 PS-100 Power Supply Card Connection .....	42
<b>5. System Programing</b>	
5.1 Programable Functions .....	43~48
5.2 Programing Operation	
(1) Programing Mode Entry .....	49
(2) Function Reset .....	49
(3) Function Registration .....	50~54
5.3 Time Schedule Programing .....	55~56
5.4 Programing Examples .....	57~59
5.5 Operating Precautions .....	60
<b>6. Operation Check</b>	
6.1 Voice and Function Tests .....	60
6.2 Troubleshooting .....	61
<b>7. APPENDIX</b>	
7.1 Typical Input/Output Application .....	62
(1) Dry Contact (Non-voltage make contact) input example	
(2) Open Collector Output Examples	
7.2 External PA paging application for tie-line systems .....	63
(1) Simultaneous station and external PA paging output	
(2) Independent external PA paging output	

# PART 1. GENERAL DESCRIPTION

## 1. Outline and Features

### 1.1 Outline

The "IC-100 SYSTEM" is a computer-controlled, fully electronic institutional communication system specially designed to enhance administrative efficiency in schools, Correctional institutes, and other related facilities.

### 1.2 Features

- Modular construction facilitates installation, maintenance and system expansion.
- Rack- or wall-mountable exchange.
- Flexible configuration meets requirements of both small and large-scale installations.  
The smallest group configuration features 1 control station and up to 15 sub-stations. The system can be expanded in groups of the same size to include up to 8 control stations, 120 sub-stations, and two C/O (outside telephone) lines or one each of C/O line and PBX (internal telephone) extension can be connected per exchange, with tie-line interconnection possible for up to 9 exchanges.
- 8 speech links available.
- Built-in programmable clock (8 schedules x 32 events).
- Random broadcast programming capability for up to 10 sub-stations, 60 zones (\*1), or 9 combination zones.
- External PA paging capability.
- Call Forwarding, Speed Dialing, Redialing, Call Transfer, and Conference functions.

**[Note] : (\*1)** The available number of individual zones is limited to up to 59 when using the "time schedule" or "external time signal trigger" function.

## 2. System Configuration and Module Functions

### 2.1 System Configuration

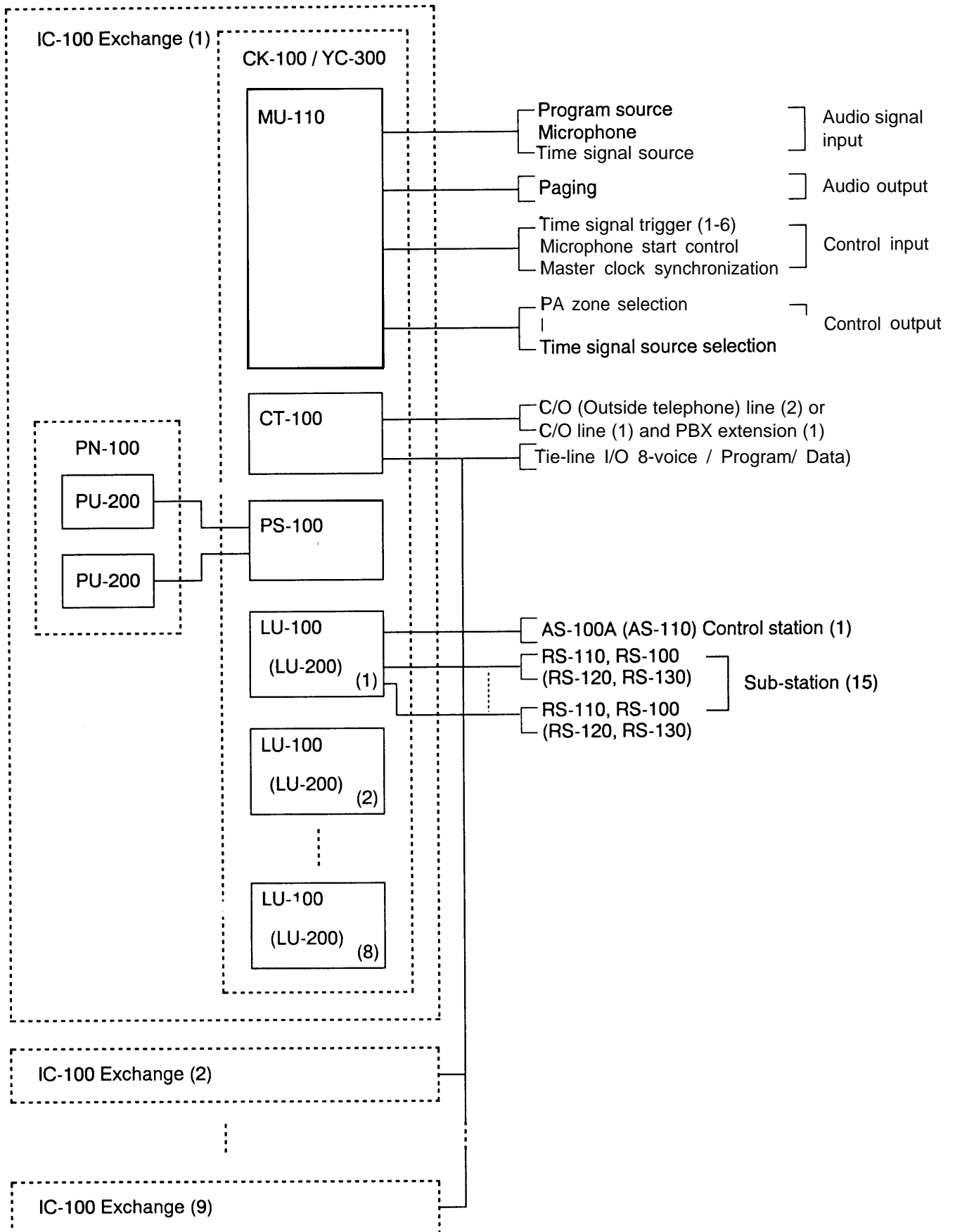

## 2.2 Module Functions

- **MU-110 Main Control Card**

Utilizing a Z80 CPU, the Main Control Card automatically controls speech path switching functions upon reception of either a dial signal from the control station or a “call” or “privacy” signal from any of the connected sub-stations. The card also generates time-programable signal tones, and provides computer communication capability through its RS-232C port.

- **CT-100 C/O& Tie-Line Card**

The C/O & Tie-line Card functions as both an outside telephone (C/O) line interface and a local tie-line interface. Its C/O line interface is compatible with both loop and ground start systems, and utilizes DTMF dialing signals for its 2 outside lines, which are in full compliance with FCC Part 68 regulations. (Either of the two lines can be connected to the PBX extension.) The tie-line interface permits interconnection of up to 9 exchanges, with 8 sets of voice input/output, 1 set of program input/output, and 1 set of control input/output.

- **LU-100 Line Card**

The LU-100 incorporates interface circuitry for control station connection, relay, talk-back, and hybrid circuitry for sub-station connection, and a speech path switch. It can drive 25V line sub-station speakers.

The control station interface outputs a dial signal to the Main Control Card upon control station dial signal reception. Other functions include FM signal demodulation, sound amplification, and power supply for control station and sub-station speaker output. One control station and up to 15 sub-stations can be connected per Line Card.

The sub-station interface features an AGC-equipped 15W power amplifier for sub-station speaker talk-back capability, relayed switching of up to 15 sub-stations, photocoupled reception of “call” and “privacy” signals, and hybrid circuitry for sub-station handset operation.

- **LU-200 Line Card**

The LU-200 incorporates interface circuitry only for one control station connection.

- **PS-100 Power Supply Card**

Receiving AC power from the PU-200 Power Transformer Unit, the PS-100 provides 5V, 15V, and 24V DC power output to all other cards in the exchange via its rectification and stabilizer circuitry. DC input is also provided for a standby battery to ensure full operating capability in case of power failure.

- **CK-100 Card Case / YC-300 Wall Mounting Frame**

The CK-100 houses all system boards. It can either be installed in an EIA standard 19" rack or independently wall-mounted in conjunction with the YC-300 Wall Mounting Frame.

- **PU-200 Power Transformer Unit**

The wall-mountable PU-200 provides two 20V/2.5A AC outputs to the PS-100 Power Supply Card to drive up to four LU Line Cards. A maximum of two PU-200's can be connected to the PS-100.



- **PN-100 Rack Mount Panel**

The PN-100 provides side-by-side rack mounting capability for up to two PU-200 Power Transformer Units.

- **AS-100A Control Station**

The AS-100A Control Station provides fully duplex communication with other control stations or handset sub-stations via its handset receiver. Also featured are “handsfree” communication capability, and 12-digit LCD display of connected sub-station No., dialed numbers, sub-station priority status, and a digital clock. It utilizes dual twisted pair cables.

- **AS-110 Control Station**

This control station is mounted in the console or wall.

- **RS-100 Switch Panel**

The RS-100 Switch Panel mounts two button switches, a red call button and a white privacy button, and controls the connected RS-110 Handset and/or a remote speaker. The flush-mount panel can be installed in a standard 1-gang electrical box and connected via a single-pair shielded cable.

- **RS-110 Sub-Station Handset (Room Station Handset)**

The RS-110 Sub-Station Handset provides fully duplex communication with the control stations or handset sub-stations. The wall-mount cradle can be installed in a standard 2-gang electrical box and connected via a single-pair shielded cable.

- **RS-120 Sub-Station**

Designed for wall mounting, this robust sub-station consists of a CALL button and a speaker.

- **RS-130 Sub-Station**

Designed for wall mounting, this sub-station consists of a CALL button and a speaker.

# PART II. INSTALLATION

## 1. Installation and Adjustment Procedure

Follow the below procedures when installing and adjusting the system.

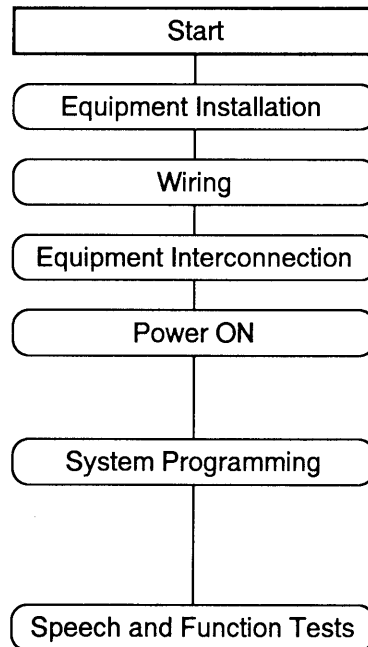

LED flashes after "Time setting" completion.  
(Refer to "Function Code 83" in "Section 5.2 (3) Function Registration".)

## 2. Equipment Installation

### 2.1 Installation Precautions

Observe the following precautions when installing the exchange.

- When mounting on the wall, confirm that the wall surface is strong enough to support the weight of the exchange. TOA cannot accept responsibility for accidents resulting from poor mounting conditions.
- Install in a location that affords easy maintenance and inspection.
- Avoid the following locations when installing equipment:
  - (1) Locations where equipment can be exposed to fire, excessive heat or sunlight.
  - (2) Locations where metal particles or dust accumulate.
  - (3) Locations in close proximity to chemicals or oil.
  - (4) Locations of high humidity or near windows where the equipment may be exposed to rain.
  - (5) Locations in close proximity to high-voltage equipment or strong electric fields.

\* Dimensional unit of drawings is indicated in millimeter in this installation handbook.

## 2.2 CK-100 Card Case

Follow the procedures below when installing the CK-100.

**[Note]** : The CK-100 must be connected to either the PU-200's case or ground.

### (1) Rack Mounting

- ① Attach the supplied rack mounting brackets to the unit.

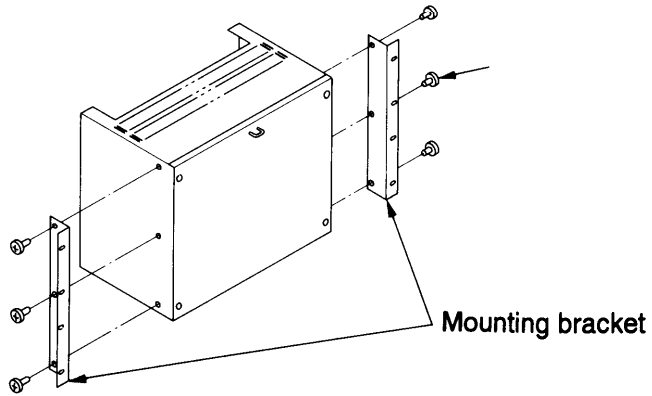

- ② Mount the unit in a standard equipment rack.

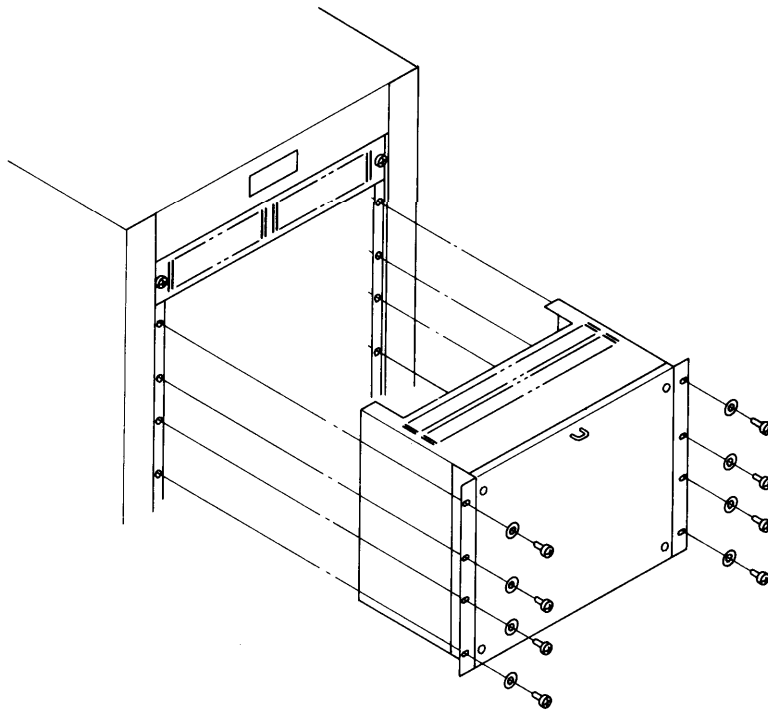

**(2) Wall Mounting** (Optional YC-300 Wall Mounting Frame required.)

- ① Attach the YC-300 frame to the wall.

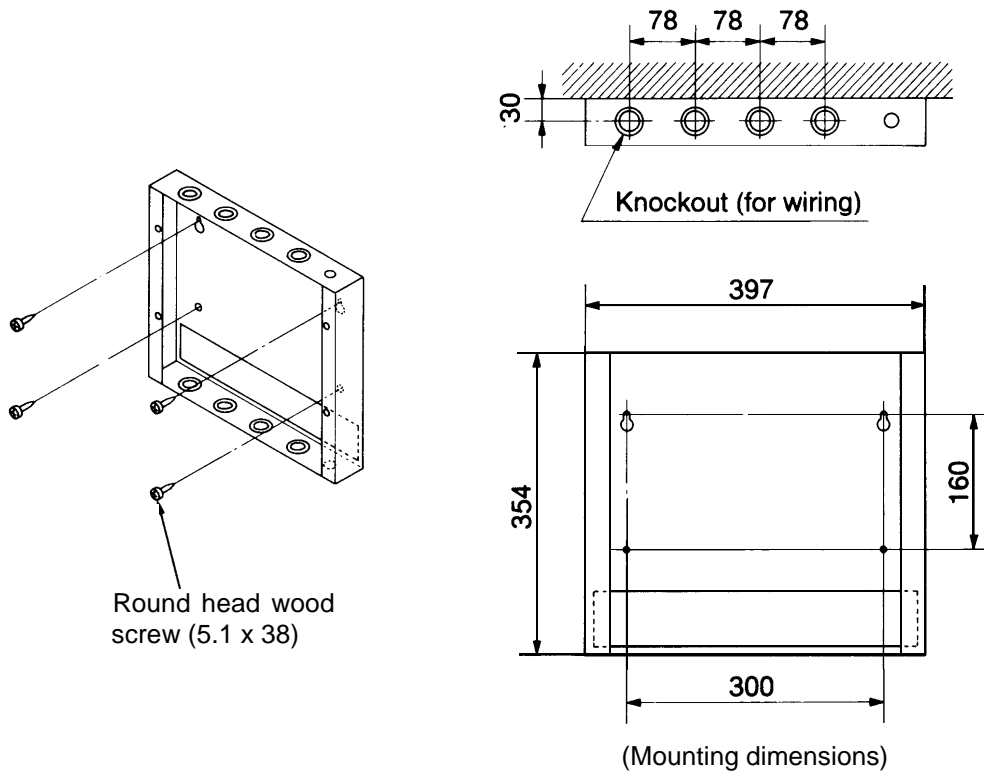

- ② After removing the CK-100's front panel, mount the unit on the Wall Mounting Frame.

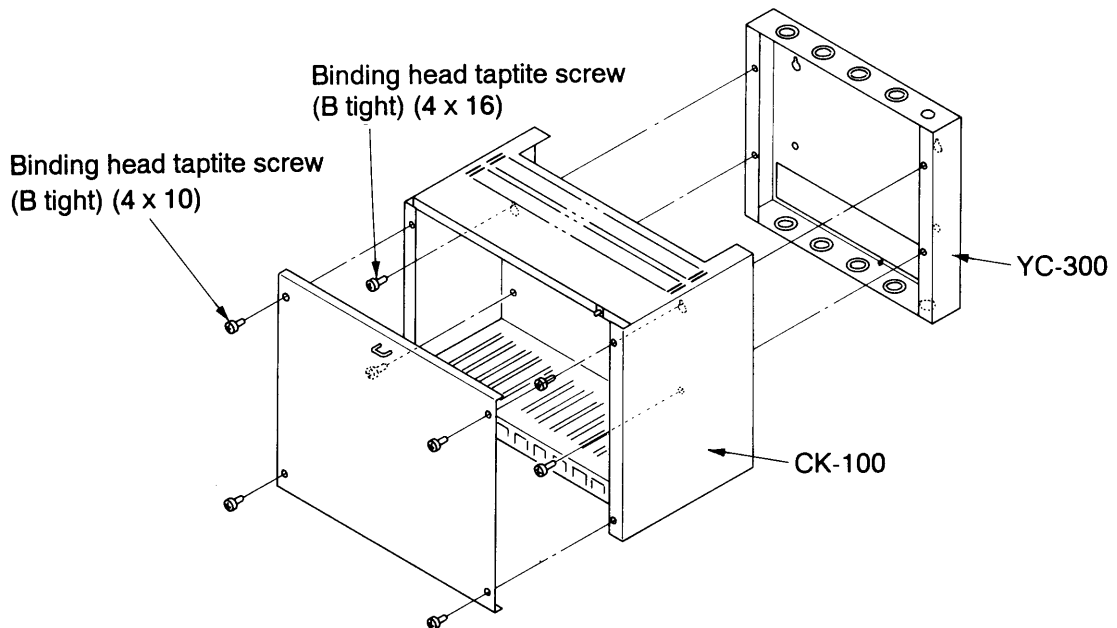

## 2.3 Power Supply

Follow the procedures below when installing the PU-200 Power Transformer Unit.

### (1) Rack Mounting (Optional PN-100 Rack Mount Panel required.)

- ① Remove the four mounting screws, then attach the supplied wall mounting kit to the unit using the removed screws.

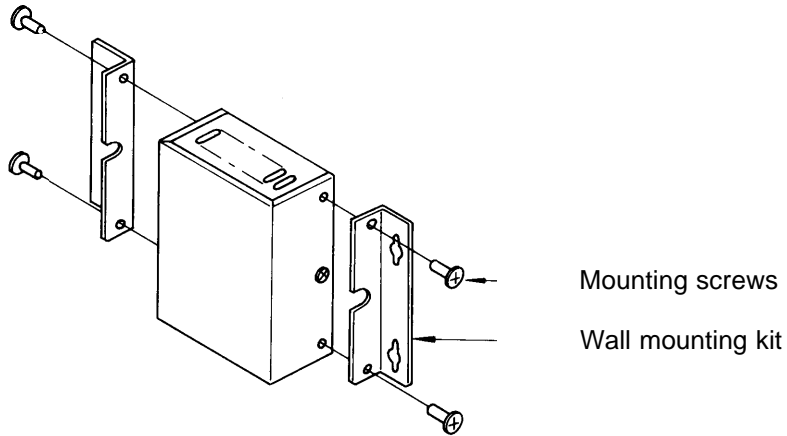

- ② Attach the PU-200 to the PN-100 panel.

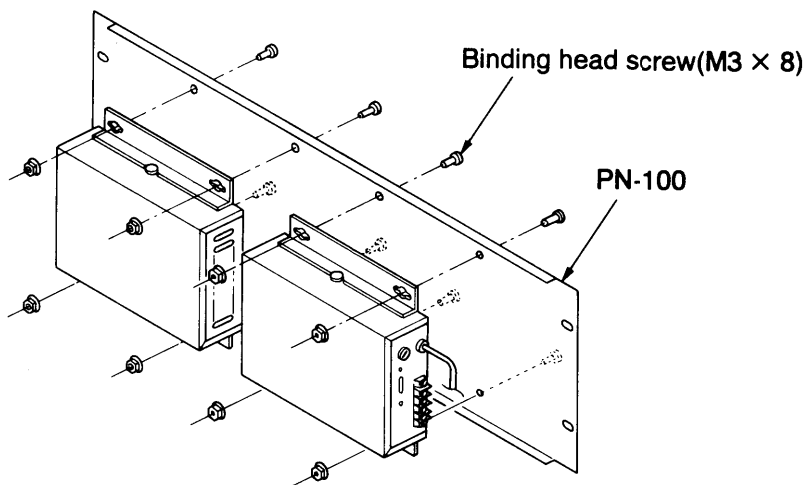

- ③ Mount the PN-100 in a standard equipment rack.

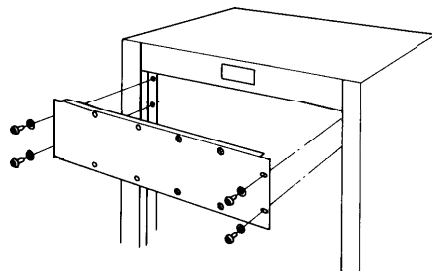

[Note] : Perform terminal wiring before mounting.

## (2) Wall Mounting

- ① Remove the four mounting screws, and attach the supplied wall mounting kit to the PU-200 using the removed screws.

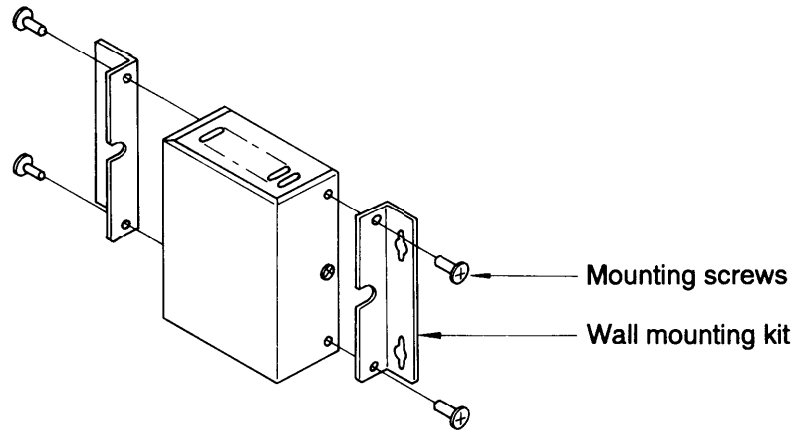

- ② Mount the unit on the wall using the supplied wood screws.

Round head wood screw (3.5 x 25)

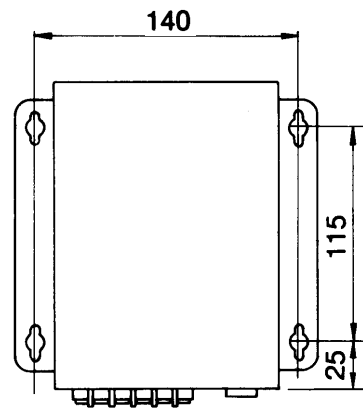
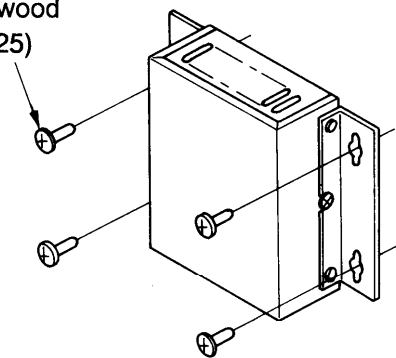

## 2.4 Sub-Station

### (1) RS-100 Switch Panel

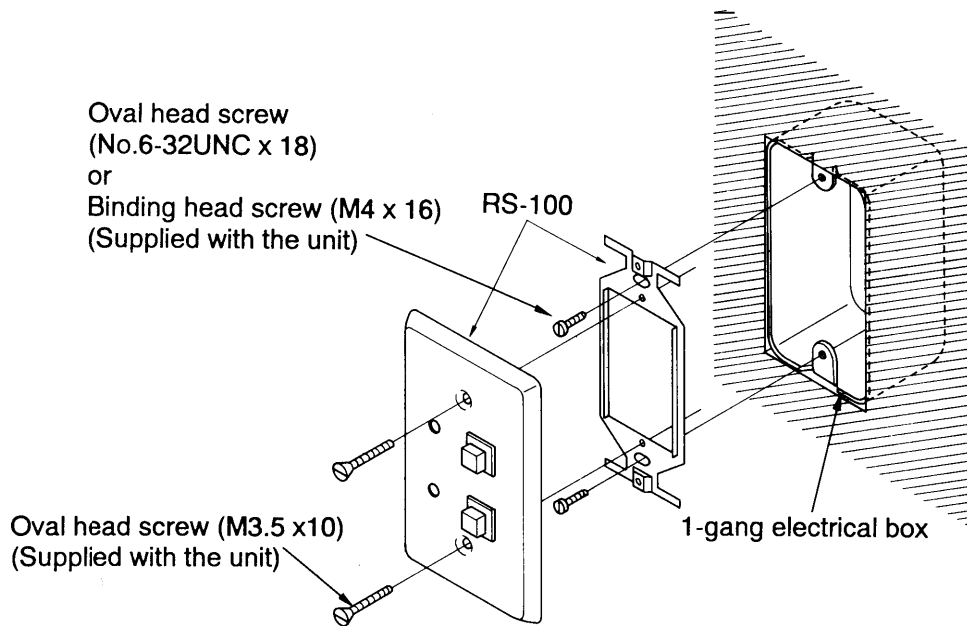

**[Note]** : Use M4 screws when the YC-301 is used.

### (2) RS-110 Sub-Station Handset

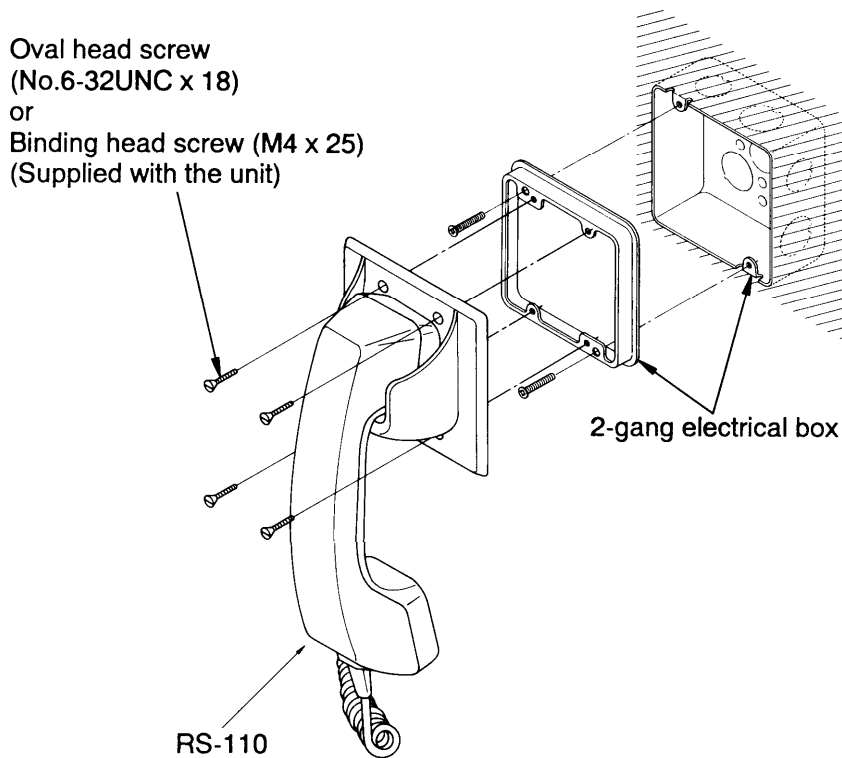

**[Note]** : Use M4 screws when the YC-302 is used.

### (3) RS-120 Sub-Station

#### (3.1) Flush-mount electrical box

<Mounting hole pitch and dimensions>

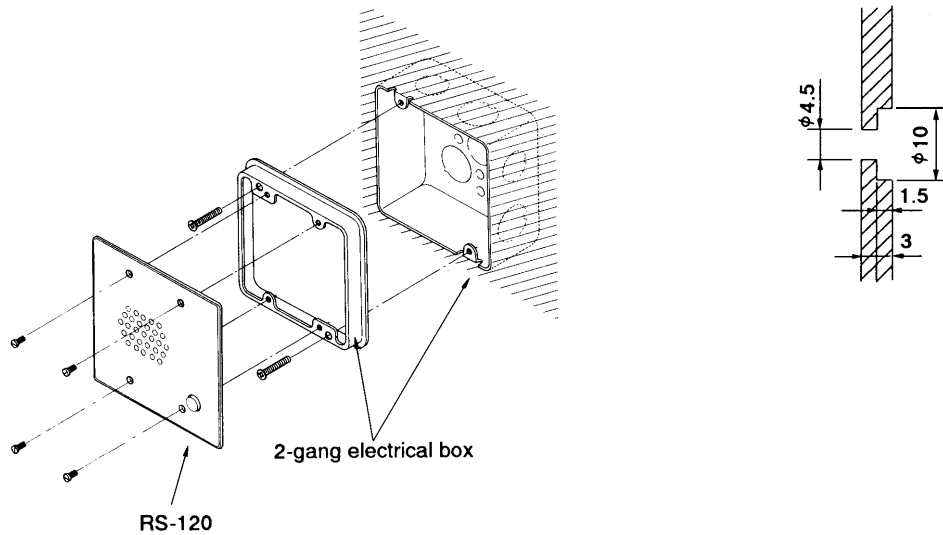

[Note] : Use M4 screws when the YC-302 is used.

#### (3.2) Dimensional diagram

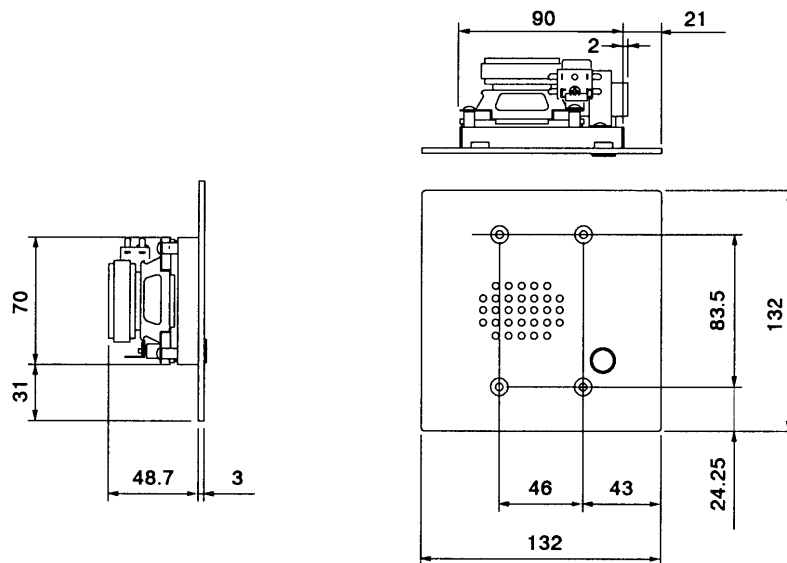



#### (4) RS-130 Sub-Station

##### (4.1) Flush-mount electrical box

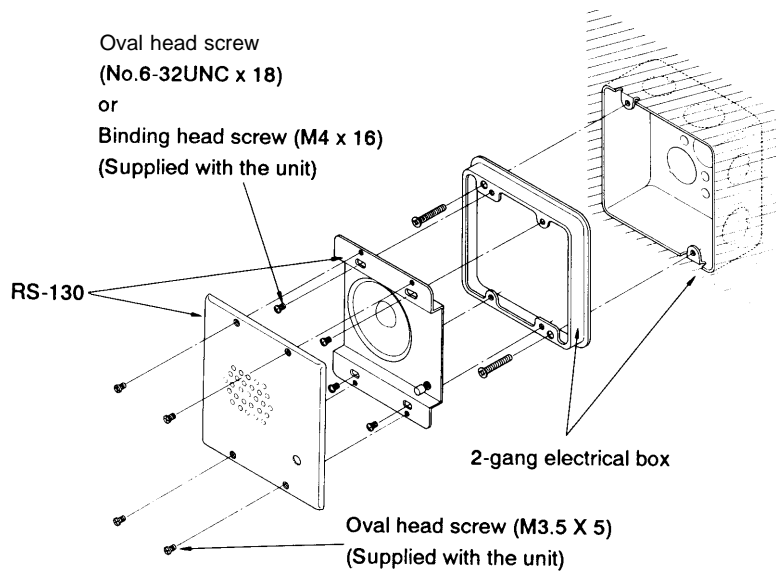

[Note] : Use M4 screws when the YC-302 is used.

##### (4.2) Dimensional diagram

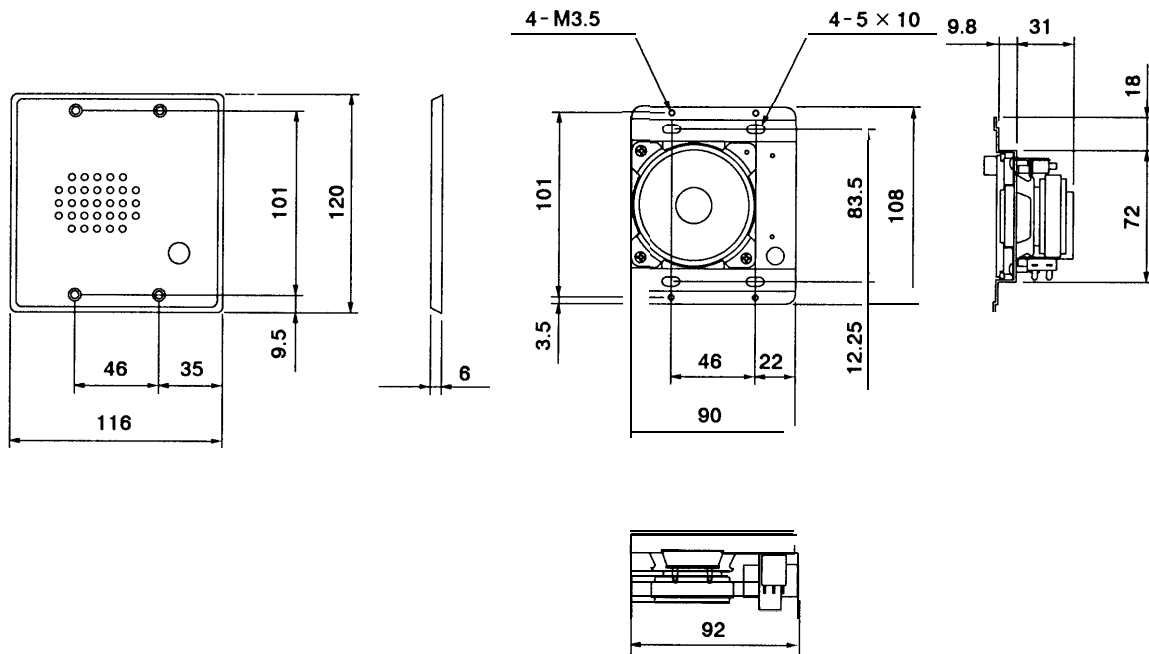

## 2.5 Control Stations

### (1) Installation

#### (1.1) AS-100A control station

- When mounting on the desk-top  
Connect the supplied modular cord.

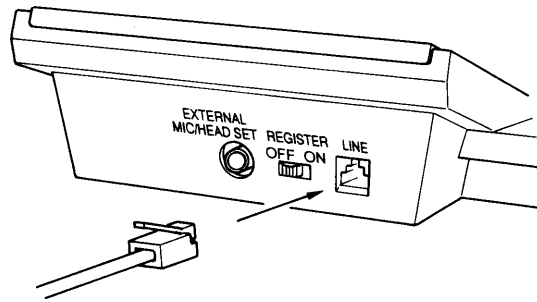

- When mounting on the wall  
Pull out, rotate, and reset the cradle hook.

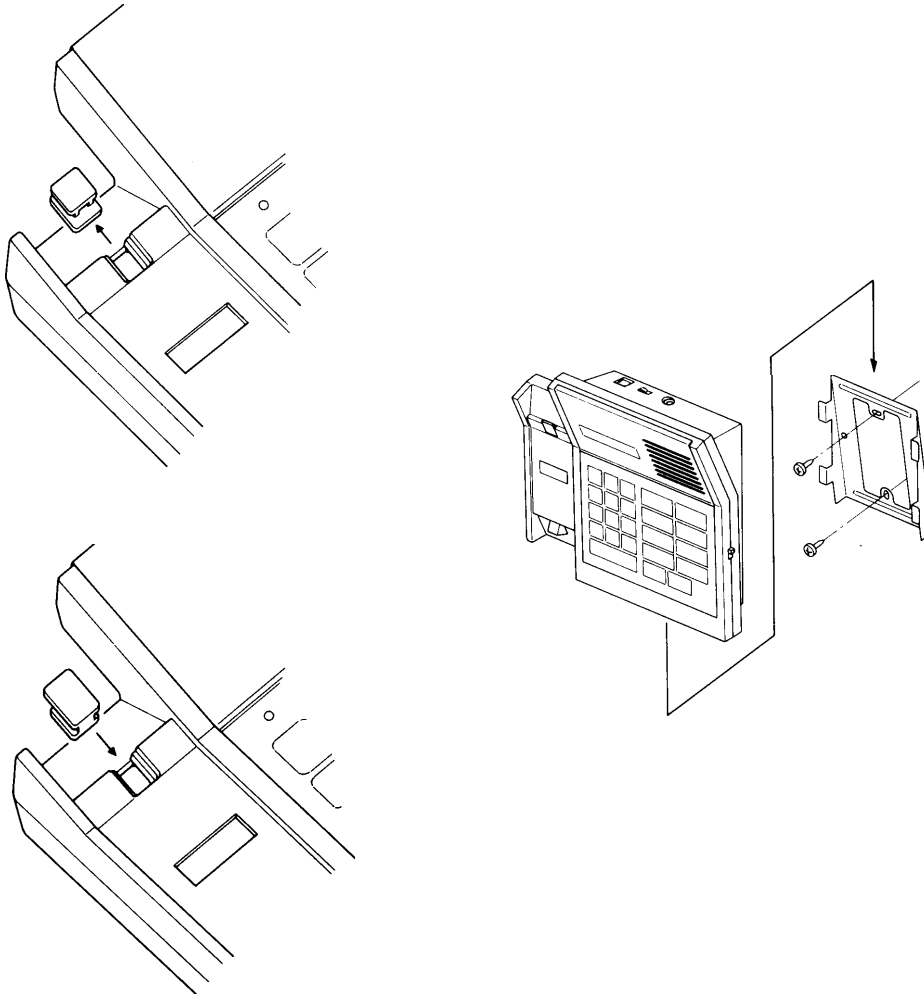

**(1.2) AS-110 control station**

**● When mounting in the console**

- ① Attach the supplied mounting kit to the AS-110.

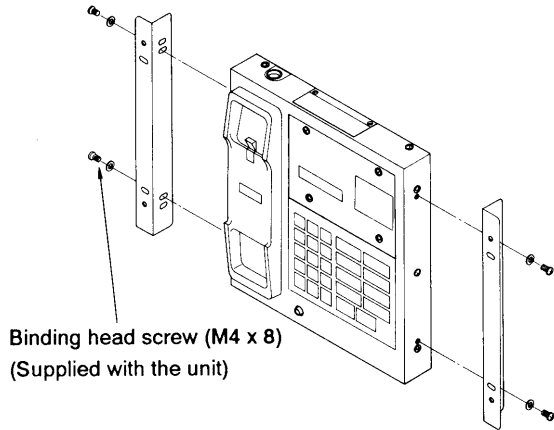

Binding head screw (M4 x 8)  
(Supplied with the unit)

Fix the AS-110 to the console.

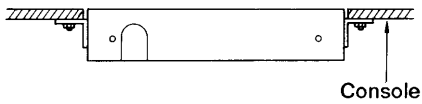

Console

**<Mounting hole pitch and dimensions>**

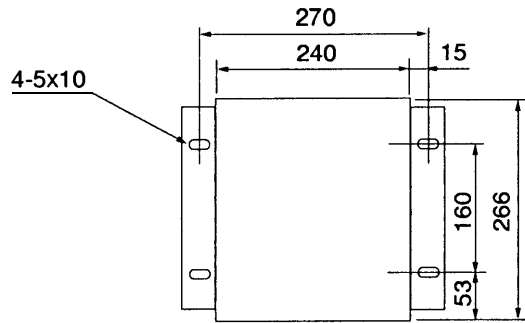

- ③ Bundle cables to be connected. (Refer to "When mounting on the wall ③" on the next page.)  
④ Fix the terminal cover. (Refer to "When mounting on the wall ⑤" on the next page.)

**● When mounting on the wall**

- ① Remove the front case.

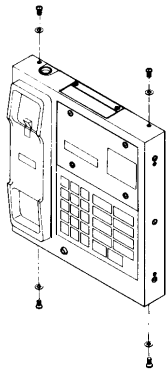

- ② Mount the remaining rear case to the wall with the supplied wood screws.

Round head wood  
(3.5 x 25)

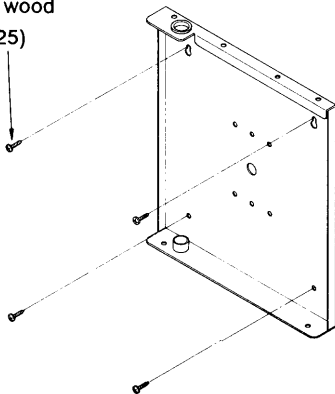

**<Mounting hole pitch and dimensions>**

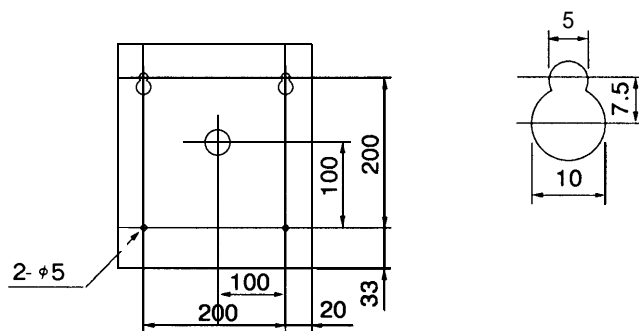

- ③ Bundle cables to be connected.

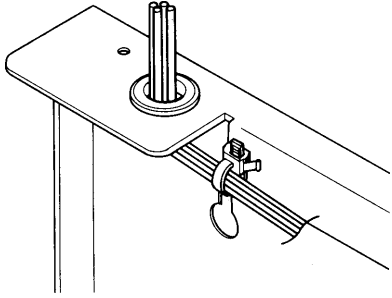

- ④ Replace the front case.

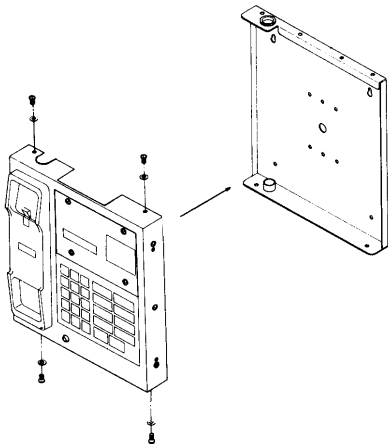

- ⑤ Connect cables to each terminal, then fix the supplied terminal cover in place.

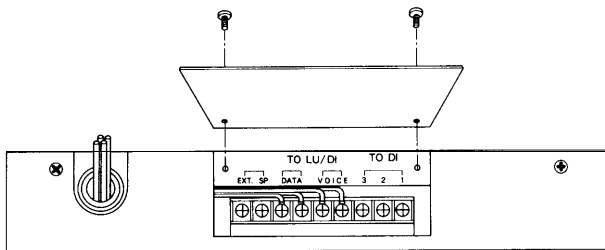

- ⑥ Remove a hook to reverse its direction, and replace it.

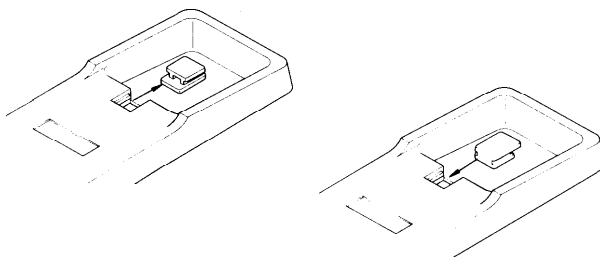

## (2) External Speaker Connection

Follow the procedures below to connect an external speaker (4-8 ohms) to the control station, when the volume level of the internal speaker is not enough.

- ① Open the case, and cut P3 or R82, located at the upper left hand corner of the p. c. card.

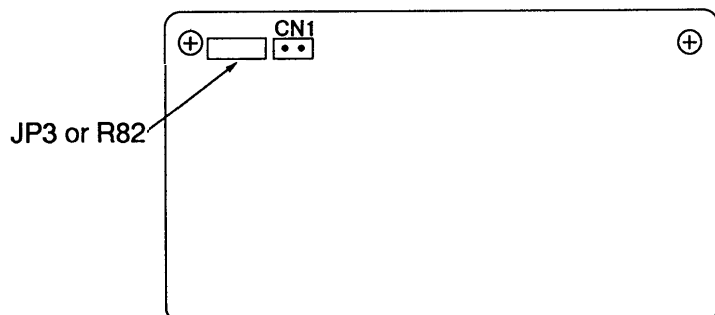

- ② Connect the speaker cable to EXT. SP terminals.

● AS-100A control station

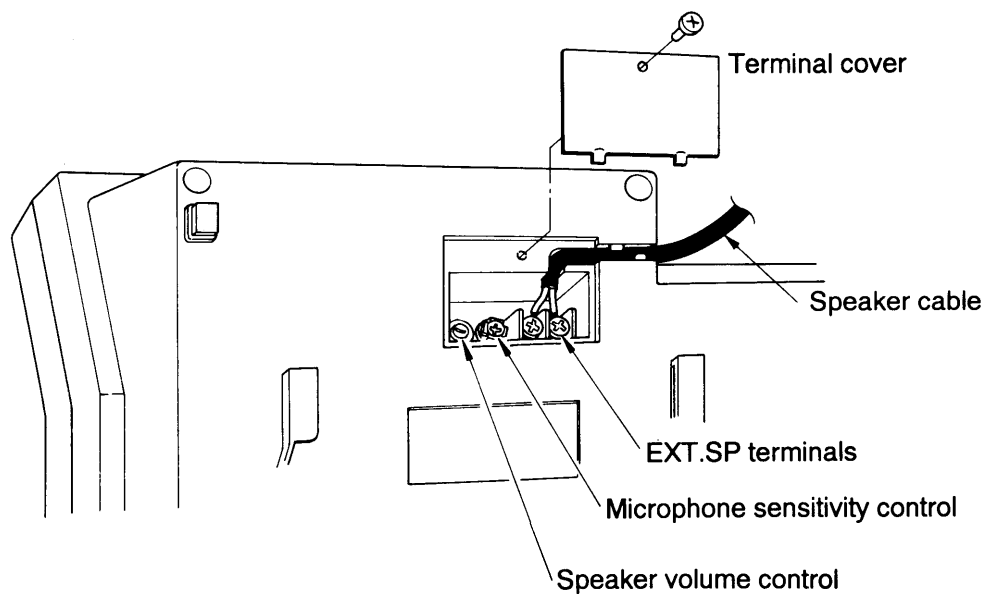

● AS-110 control station

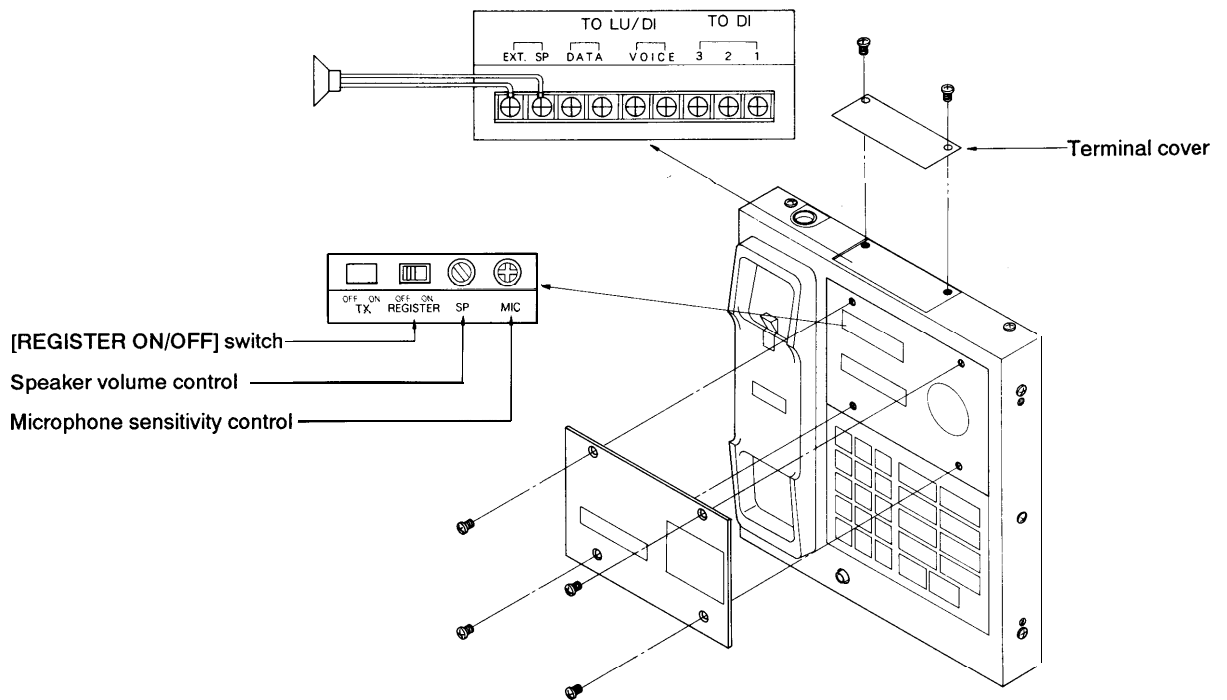

**(3) Speaker Volume and Microphone Sensitivity Adjustment**

The control station's speaker volume and microphone sensitivity can be adjusted at their respective controls, located under the terminal cover. Both controls are factory-preset to their maximum positions.

Refer to (2) "External Speaker Connection".

**(4) External Microphone or Headset Connection**

A microphone or headset can be connected for use instead of the handset. Refer to the illustration below for connection.

● AS-100A control station

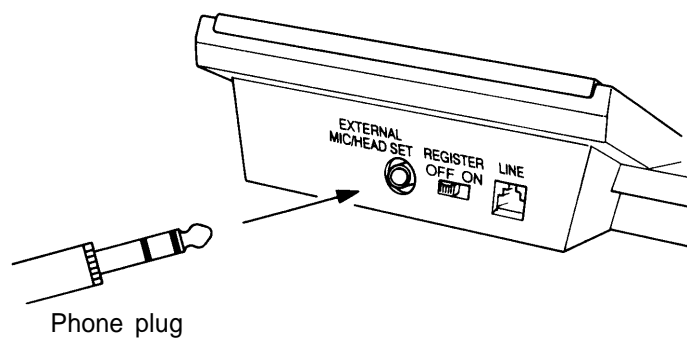

- AS-110 control station

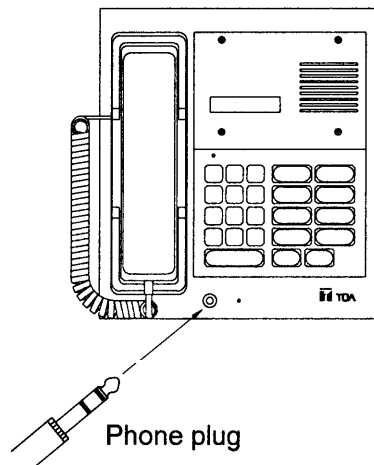

- Phone plug

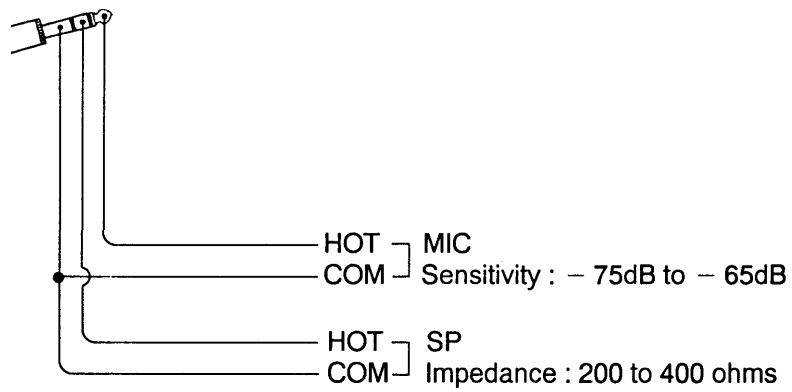

- When the control station's internal speaker volume stops at the headset use, cut JP4 on the internal p.c. board.

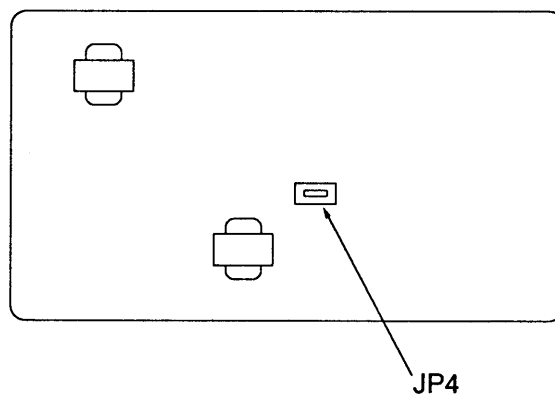

## Line Installation

- Be sure to use 2-pair twisted cable to wire the control stations, and single pair twisted cable with shield for the sub-stations.
- Ensure the control station and sub-station cables are isolated from power or data transmission lines.
- Refer to the following table for the maximum recommended length for each cable type.

Core Diameter	Control Station	Sub-Station
24AWG (0.52 mm)	3000ft (1000m)	1800ft ( 500m)
22AWG (0.65 mm)	4800ft(1500m)	2800ft ( 800m)
20AWG (0.82 mm)	6500ft (2000m)	4500ft(1300m)

## 4. Interconnection

### 4.1 Card Installation and Connection

- Be sure to install each card in the CK-100 in the following positions.

(When using CT-100)

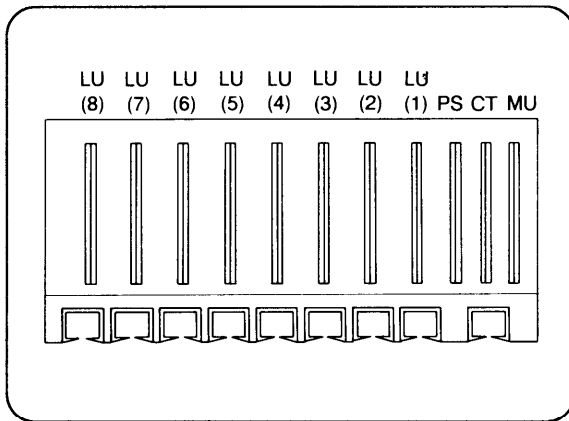

(Front view)

(When not using CT-100)

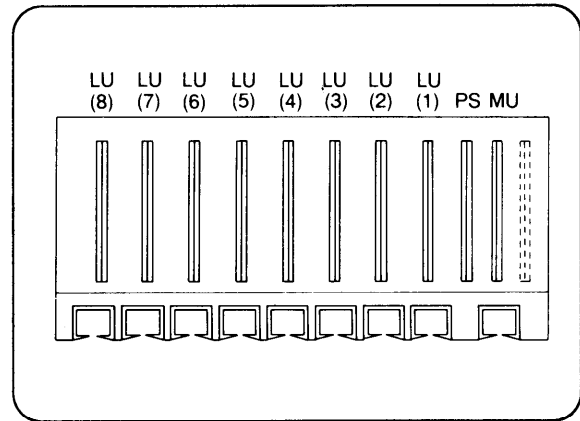

(Front view)



- Interconnect such units as the MU cards and LU cards as shown below.

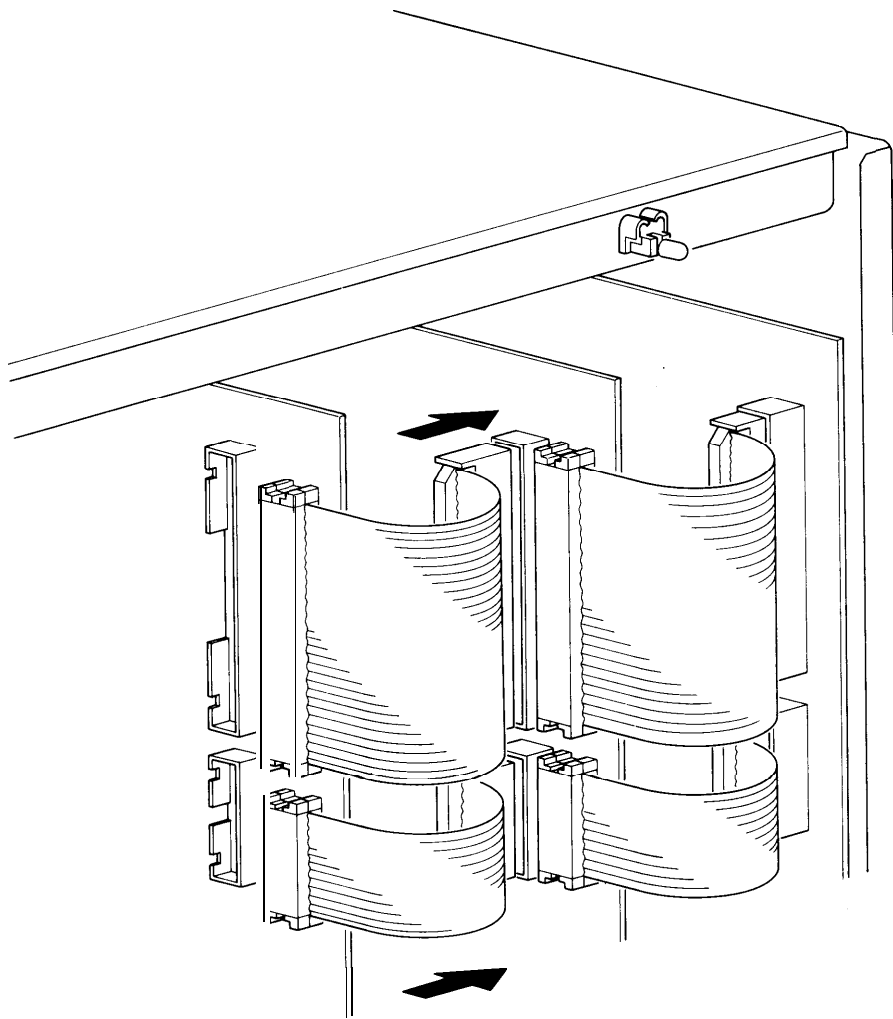

- Connect stations and C/O (outside telephone) lines to their respective cards as shown below.

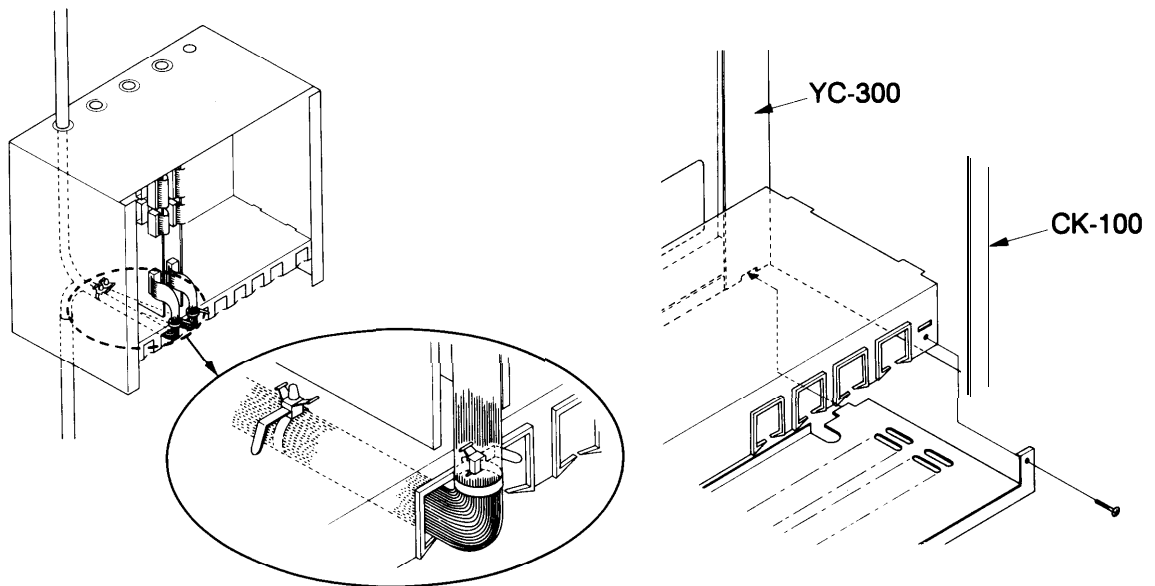

## 4.2 MU-110 Main Control Card Connection

### (1) External Input and Output Controls

The MU card interfaces the IC-100 system to external components to enable the following functions using I/O audio or control signals. Connect the MU card's I/O terminals to the external components, and perform required system programming.

#### (1.1) Program source input

Connect an external sound source to "Program Source Input" (CN4-1) for a single exchange system. Refer to Section 4.4 "CT-100 C/O & Tie-Line Card Connection" for a tie-line system.

#### (1.2) External microphone all-call paging

After connecting the microphone to "Microphone Input" (CN4-2), connect a microphone switch to "Microphone Start Control Input" (CN7-4). All-call paging can then be initiated by shorting the control input terminals. (Up to 8 seconds are needed before paging output depending on the number of exchanges in the case of a tie-line system.) This all-call paging is identical with that placed at the control station in priority level. When other all-call paging is already being made, if the control terminals are kept shorted, the external microphone all-call paging is allowed to go through upon completion of the current paging.

#### (1.3) External time signal source input

Up to three external sources can be connected to "External Time Signal Source Input" (CN4-3). To select one of them, control an external input source selector using the signal from "External Time Signal Source Selection Output" (CN5-4 & CN5-5).

Status	CN5-5	CN5-4
No source selected	0	0
Source No. 1	0	1
Source No. 2	1	0
Source No. 3	1	1

1: Transistor ON  
0: Transistor OFF

#### (1.4) PA Paging

Station paging can also be provided through a connected external PA system. Although there is only one PA paging output (CN4-4), an additional two-bit control output permits signal assignment to up to three different external PA zones, which can be selected by controlling an auxiliary selection device using "PA Zone Selection Output" (CN5-1 & CN5-2).

PA Zone Selection	CN5-2	CN5-1
No zone selected	0	0
Zone No. 1	0	1
Zone No. 2	1	0
Zone No. 3	1	1

Open collector output  
1: Transistor ON  
0: Transistor OFF

**[Note]** : Zone selection dialing operation corresponding to each status must be registered under "PA Paging Zone Assignment [Function Code 43]" of system programming. Refer to 7. Appendix 7.2 "External PA Paging" application for tie-line systems.

#### (1.5) External Bell Control

At the time of time signal output or external time signal trigger, an external bell can also be sounded by providing a control signal from "External Bell Control Output" (CN5 - 3). Refer to "System Programming [Function Code 51]".

### (1.6) External Time Signal Trigger

By shorting CN6-1/6-2, CN6-3/6-4, or CN7-1/7-2 terminals using one-shot (closure) control signals (Closure-edge trigger, pulse width : min. 10 msec.) from an external timer, time signals can also be output other than an internal timer (System Programming [Function Code 51]). Note that terminals CN7-1 and 7-2 cannot be used for this function if they are used for "Automatic C/O transfer by external start input" function.

### (1.7) Master Clock Synchronization

If "Master Clock Sync Input" (CN7-3) and COM terminals are shorted, seconds are reset to zero for an internal clock. (Closure-edge trigger, pulse width : min. 10 msec.)

## (2) Input/Output Terminals

CN3		Operation indication LED connector	
CN4	1	Program source input (-10 dBV, 33k Ω, unbalanced)	
	2	Microphone input (-70 dBV / 0 dBV, 3.3k Ω, unbalanced)	
	3	External time signal source input (-10 dBV, 10k Ω, unbalanced)	
	4	Paging output (-10 dBV, unbalanced)	
	5	COM	
CN5	1	} PA zone selection output 1 (*2)	
	2		PA zone selection output 2 (*2)
	3	External bell control output (*2)	
	4	} External time signal source selection output 1 (*2)	
	5		External time signal source selection output 2 (*2)
CN6	1	} External time signal trigger input 1 (*3)	
	2		External time signal trigger input 2 (*3)
	3		External time signal trigger input 3 (*3)
	4		External time signal trigger input 4 (*3)
	5	COM	
CN7	1 (*1)	External time signal trigger input 5 (*3)	
	2 (*1)	External time signal trigger input 6 (*3)	
	3	Master clock sync input (*3)	
	4	Microphone start control input (*3)	
	5	COM	

**[Note]** : (\*1) If "Auto-call C/O transfer" is selected under "External control input function selection" of System programming [Function code 57], the functions of terminals CN7-1 and 7-2 will be as shown in the following table:

CN7-1	Start of auto-call C/O transfer of control station No.15
CN7-2	Start of auto-call C/O transfer of control station No.31

(\*2) Open collector output 20 mA, +24 V max.

(\*3) Dry contact (No-voltage make contact) input

(\*2) and (\*3) refers to "7. Appendix (7.1) Typical Input/Output Application".

### (3) Input/Output Terminal Connection Example

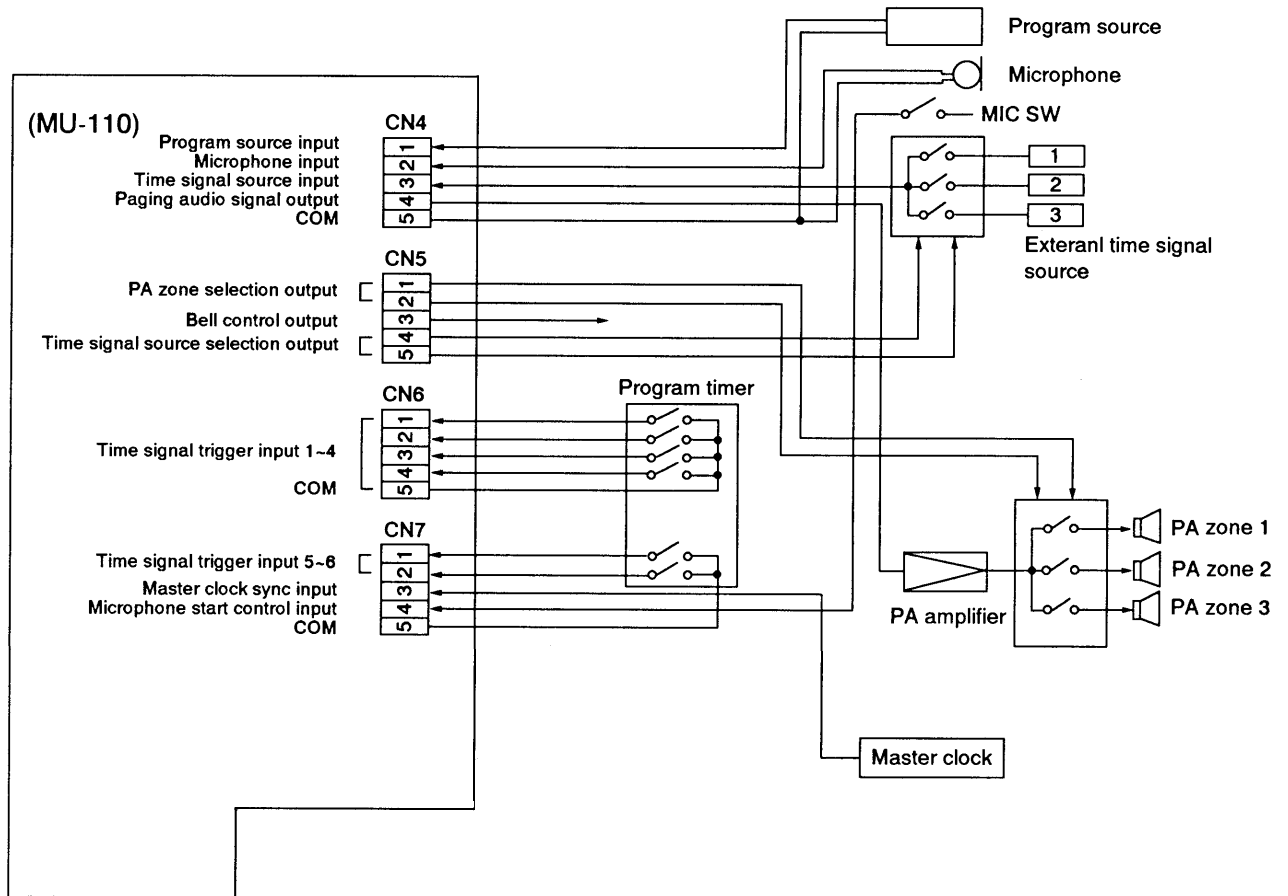

#### ● External time signal source connection for tie-line systems

[Applicable to “Time Schedule”, “External Time Signal Trigger”, and “Manual Time Signal Output” functions.]

- The external source must be connected to all exchanges having desired signal output zones.
- For the “Time Schedule” function, data may only be programed into the EX-1 exchange.

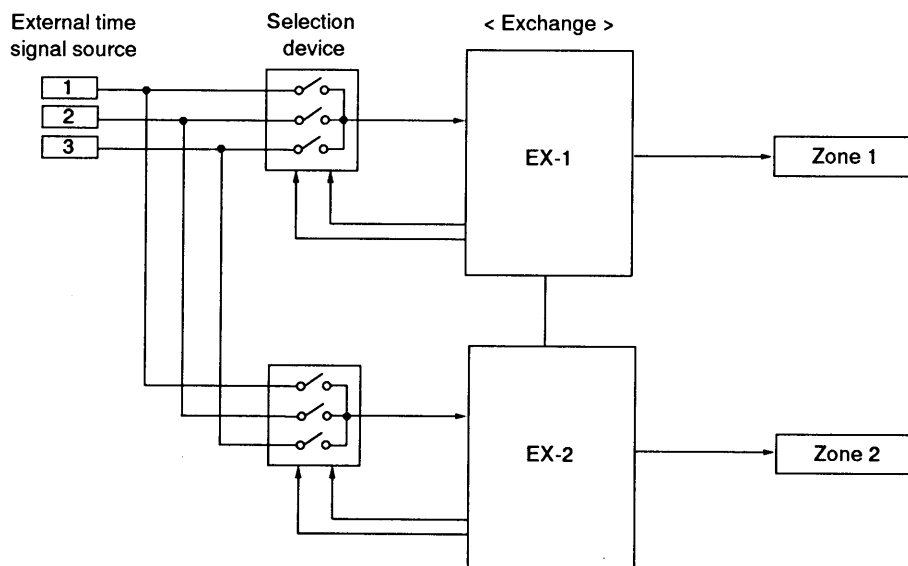

#### (4) Jumper Setting and Volume Adjustment

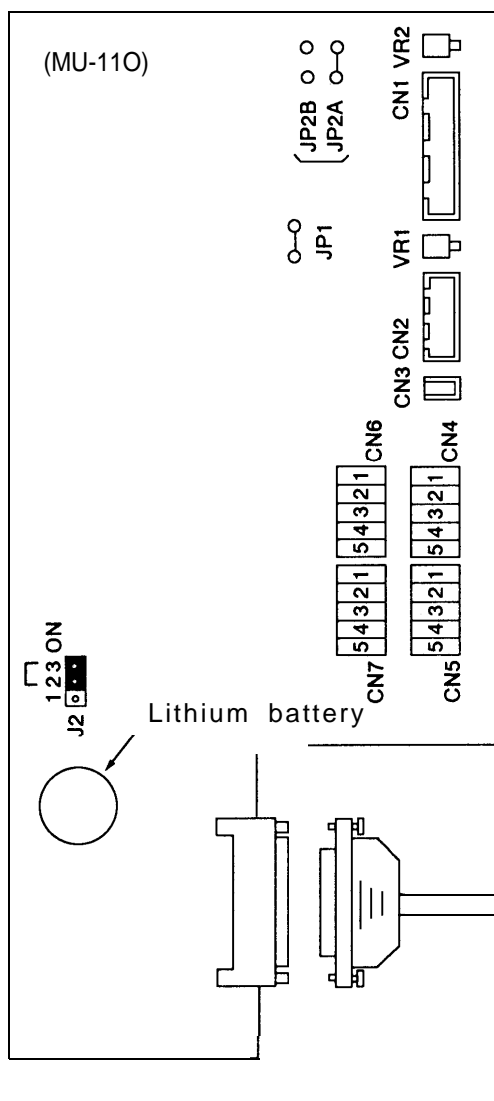

(4.1) VR1 (External time signal volume control)  
Turning this control clockwise increases the volume.

(4.2) VR2 (Sound source master volume control)  
Master volume control for  
1) External time signal,  
2) External microphone,  
3) 4-note chime (paging pre-announcement tone), and  
4) Westminster chime (time signal).  
Turn this control clockwise to increase the volume.

(4.3) Jumper JP1 (Program source ON/OFF)  
Refer to Section 4.4 "CT-100 Connection".

(4.4) Jumpers JP2A/JP2B (Microphone input sensitivity selection)  
Microphone input (CN4-2) sensitivity can be set to either  $-70\text{dBV}$  (factory-preset) or  $0\text{dBV}$ . Connect JP2A for  $-70\text{dBV}$  sensitivity, and JP2B for  $0\text{dBV}$ .

#### (4.5) Lithium Battery and Jumper J2 (Lithium battery ON/OFF)

- Jumper J2 for internal clock backup is factory-preset to OFF. Be sure to set to ON at the time of installation.
- The lithium battery keeps the internal clock in operation when the power of the system is switched off. Its approximate life is two to three years, but this changes depending on its environment and conditions of use. The control station displays inaccurate time as the battery reaches the end of its life. In such a case, replace the detachable battery with the same type of lithium battery.

## (5) Cable Connection

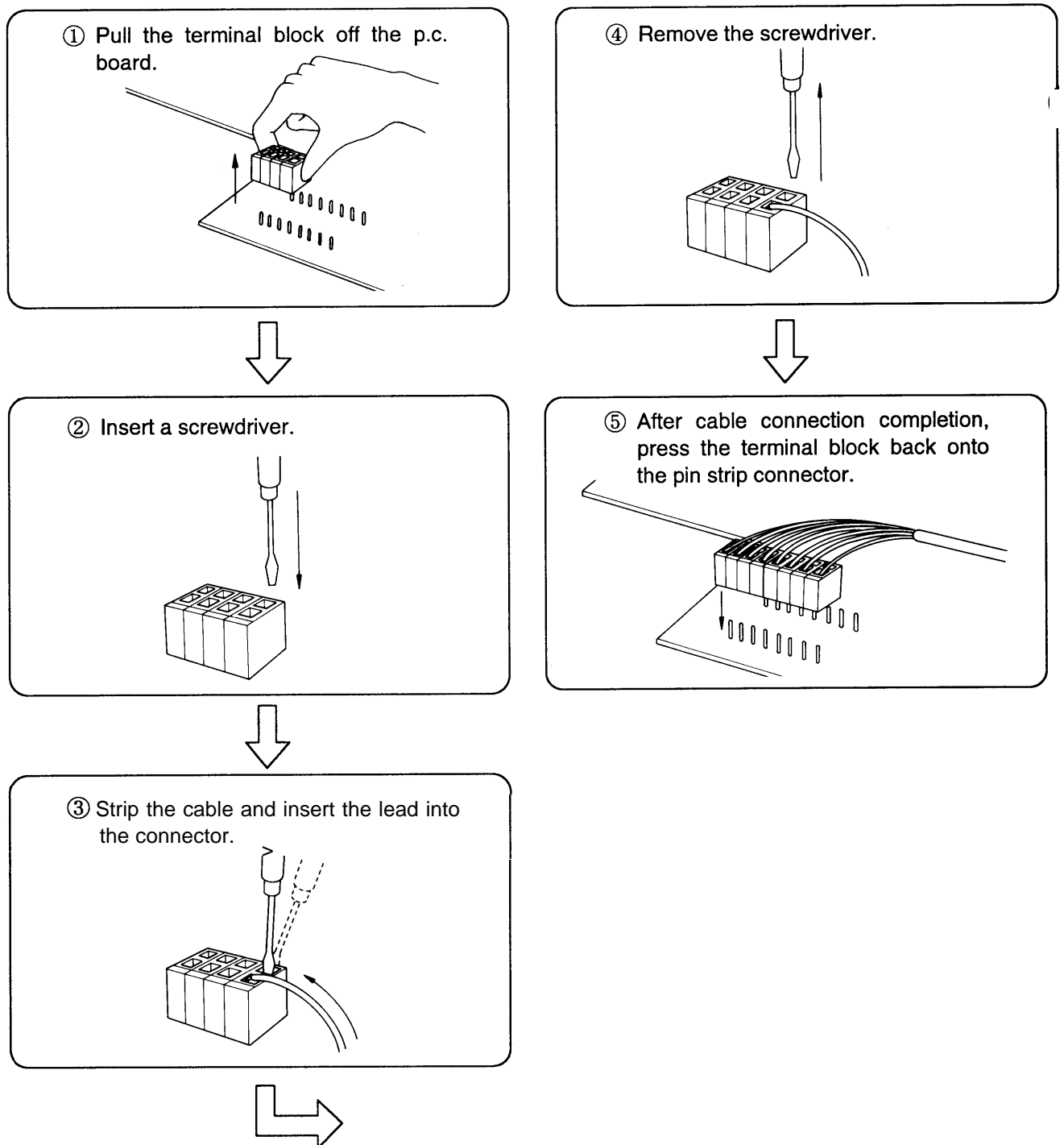

### 4.3 LU Card and Control Station/Sub-Station Connection

#### (1) LU Card Number Setting

One control station and up to 15 sub-stations can be connected to each LU card, and a maximum of eight LU cards can be installed in one CK-100 card case, thus permitting interconnection of a total of eight control stations and 120 sub-stations per exchange system.

Because the IC-100 system is designed to transmit control signals via a common bus, the LU card number (address) has to be established. Using pliers or tweezers, set switch SW1 on each LU card according to the connected station numbers as shown below. (SW1 is factory-preset to position "1".)

LU Card No.	Station Line No.		SW1 Position
	Sub-Station	Control Station	
1	000~014	015	
2	016~030	031	
3	032~046	047	
4	048~062	063	
5	064~078	079	
6	080~094	095	
7	096~110	111	
8	112~126	127	

**(2) LU Card Connection**

**(2.1) Cable connection**

① Pull the terminal block off the p.c. board.

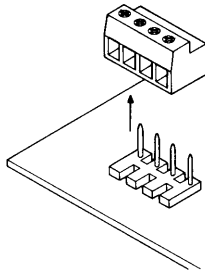

③ Strip the cable and insert the lead into the connector. Tighten the screw.

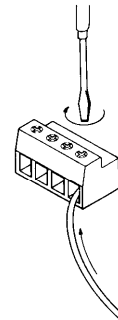

② Loosen the screw.

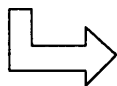
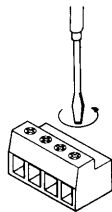

## (2.2) Control/sub-station connection

Connect the control station line to connector CN5 and the sub-station lines to connectors CN6 through CN20 as shown in the figures below.

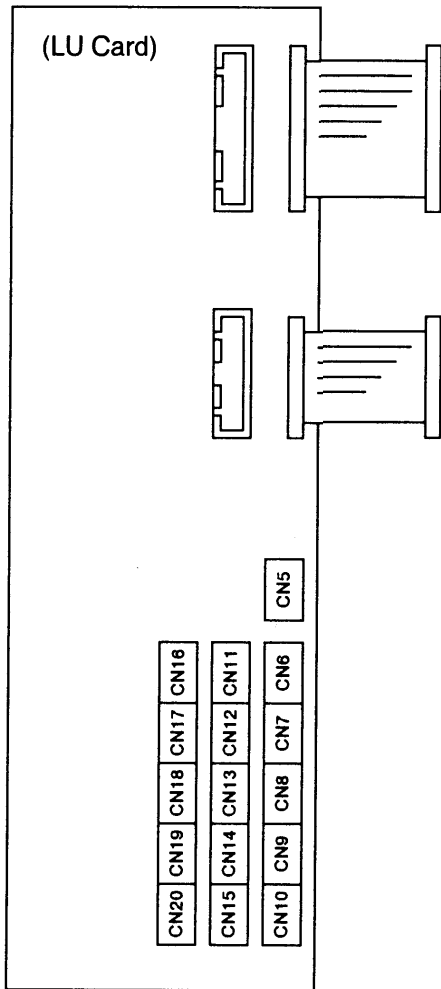

LU No. CN No.	Station Line No.							
	LU1	LU2	LU3	LU4	LU5	LU6	LU7	LU8
CN 6	000	016	032	048	064	080	096	112
CN 7	001	017	033	049	065	081	097	113
CN 8	002	018	034	050	066	082	098	114
CN 9	003	019	035	051	067	083	099	115
CN10	004	020	036	052	068	084	100	116
CN11	005	021	037	053	069	085	101	117
CN12	006	022	038	054	070	086	102	118
CN13	007	023	039	055	071	087	103	119
CN14	008	024	040	056	072	088	104	120
CN15	009	025	041	057	073	089	105	121
CN16	010	026	042	058	074	090	106	122
CN17	011	027	043	059	075	091	107	123
CN18	012	028	044	060	076	092	108	124
CN19	013	029	045	061	077	093	109	125
CN20	014	030	046	062	078	094	110	126
CN 5	015	031	047	063	079	095	111	127



### (3) Control Station Connection and Number Setting

#### (3.1) AS-100A control station

Connect the AS-100A as shown below using a 6-pin modular jack.

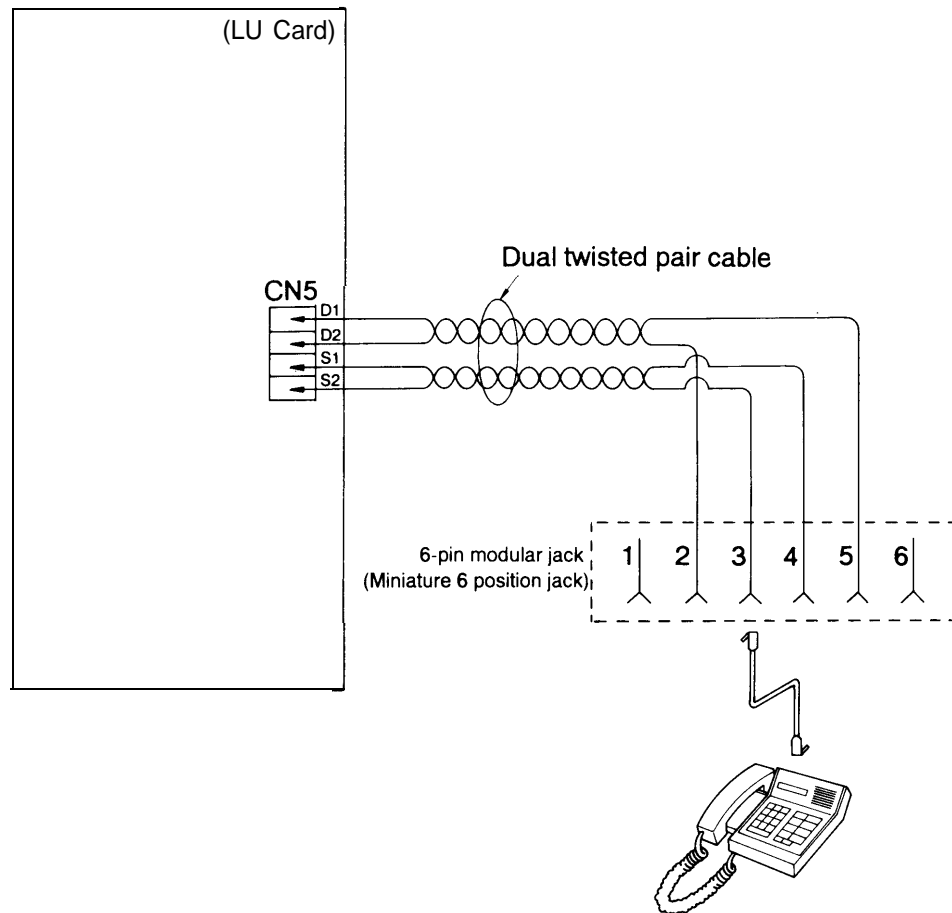
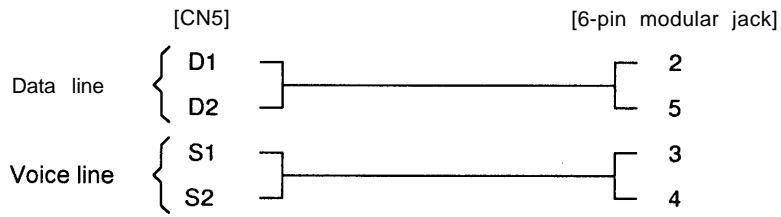

### (3.2) AS-110 control station

Connect the control station as shown below.

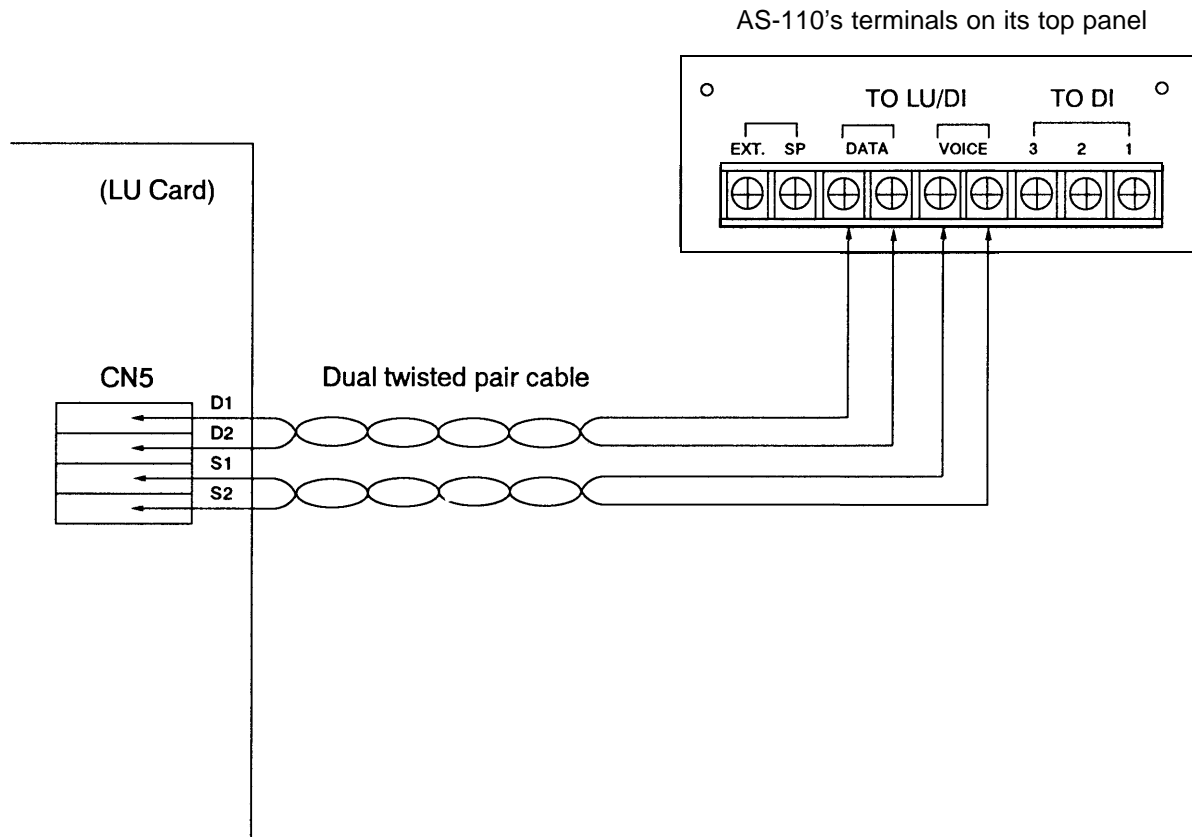

### (3.3) Control Station Number Setting

To enable the control station to properly operate, the same number as that of the LU card to which the control station is to be connected has to be registered for the control station. Follow the procedures below. (The control station is factory-preset to position "1".)

- (1) Connect the control station to the LU card.
- (2) Switch on the power of the system,
- (3) Set the [REGISTER] switch to ON.
- (4) Press the **PUSH TO TALK** key.
- (5) Dial the connected LU card's number. (Example No.3)
- (6) Press the **PUSH TO TALK** key.
- (7) Set the [REGISTER] switch to OFF.

Prog mode
St. addr 1
St. addr 3

**(4) RS-100 Switch Panel and RS-110 Sub-Station Handset Connection**

Connect the sub-station to the LU-100 as shown below. Ensure to install the MT-677 matching transformer when a 100V line speaker is used.

- When not using an RS-110 sub-station handset.

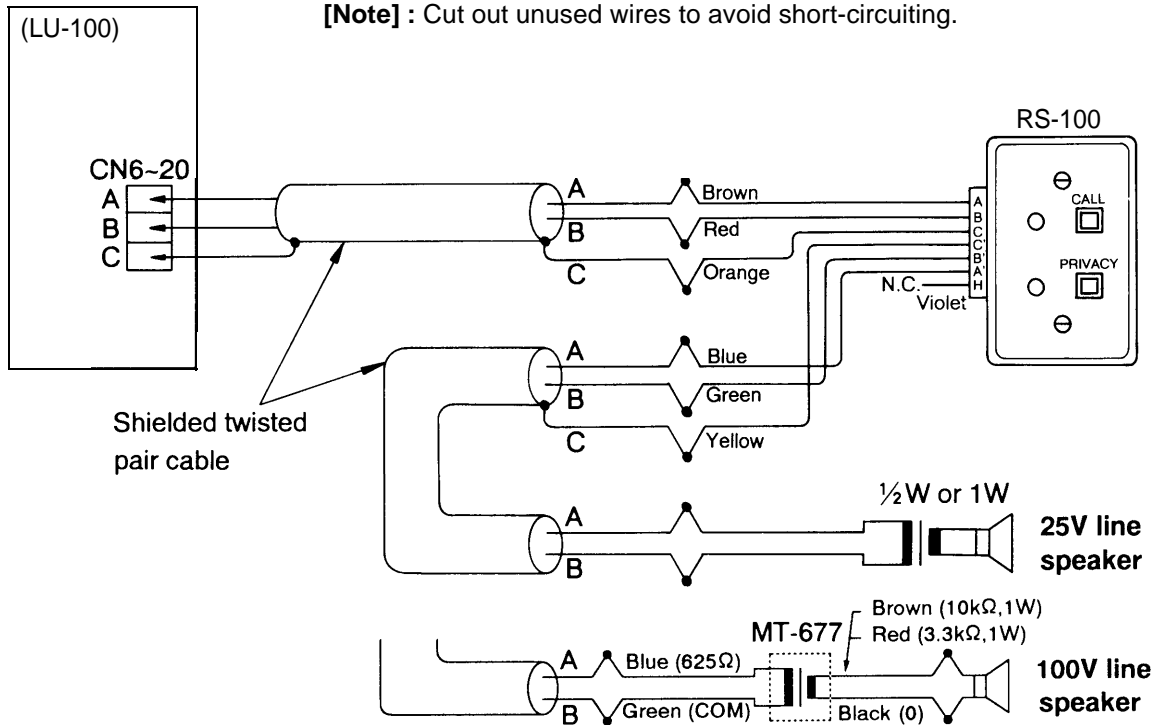

- When using an RS-110 sub-station handset.

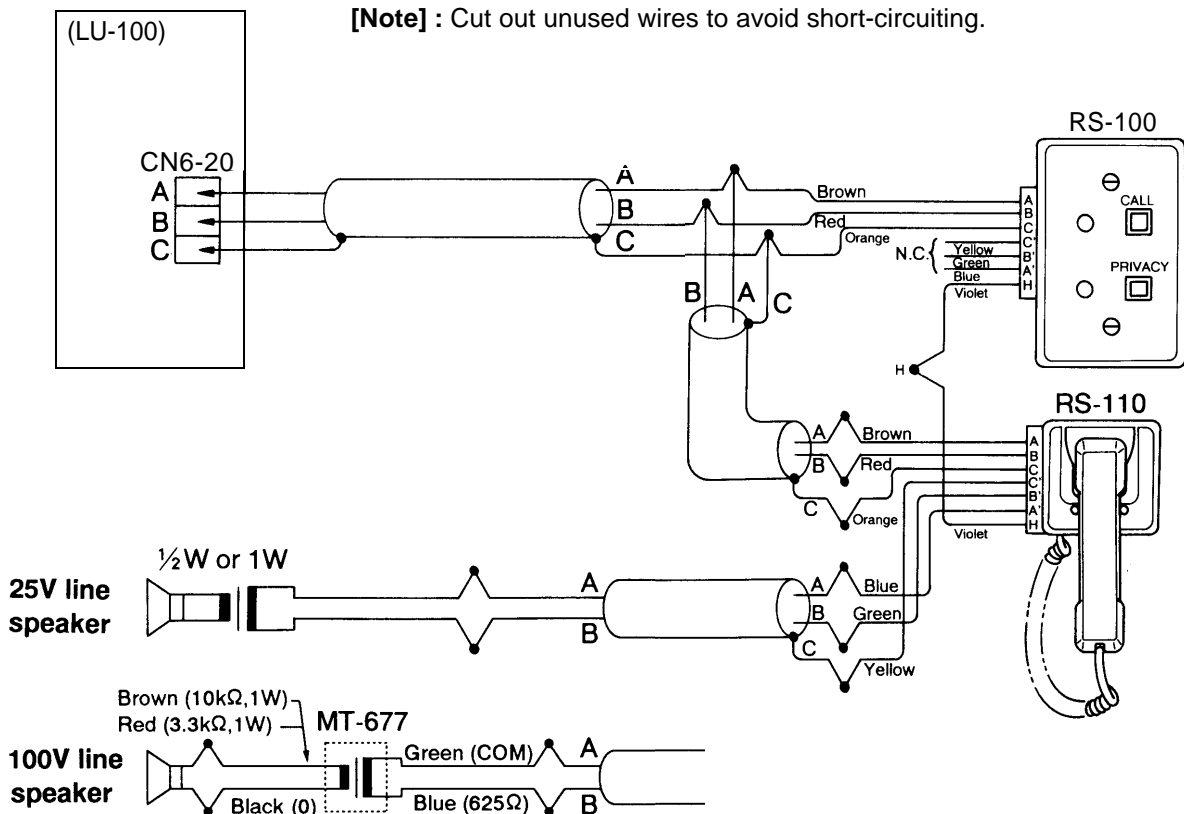

● Appearance of MT-677 Transformer

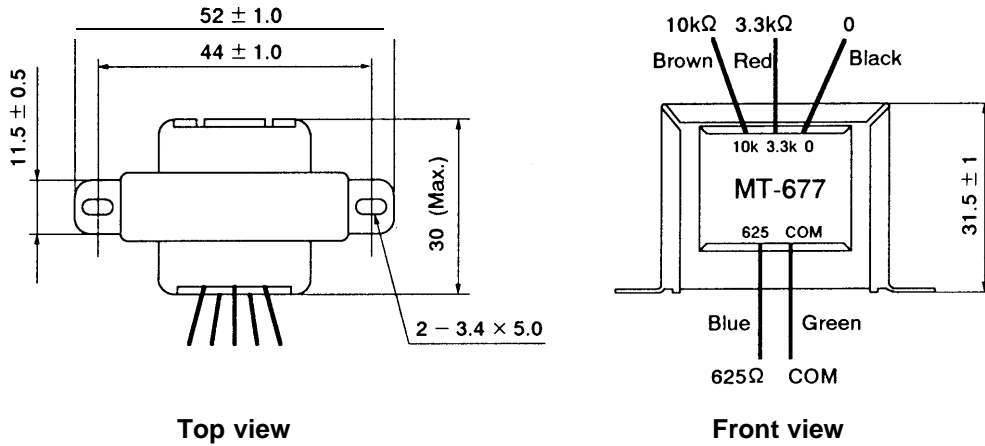

(5) RS-120/RS-130 Sub-Station Interconnection

(5.1) Connection to the LU-100 (for 25V line)

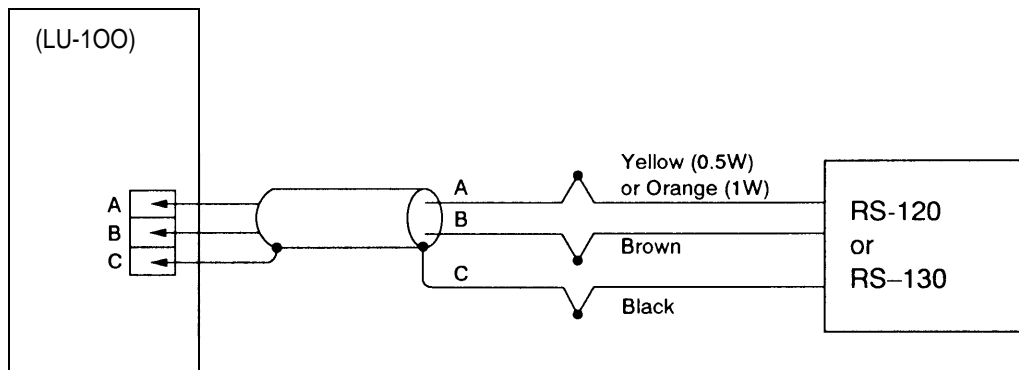

(5.2) RS-120/RS-130 part description

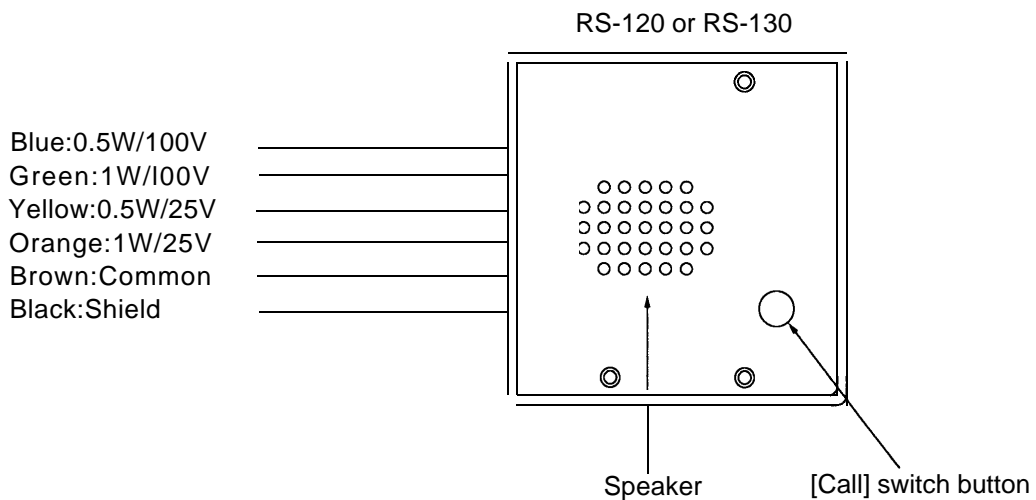

## (6) RS-102 Sub-Station Connection

The RS-102 sub-station is used when connecting the existing switches, speakers, LEDs, etc. to the IC-100 system.

### (6.1) When not using the sub-station handset (Room station handset)

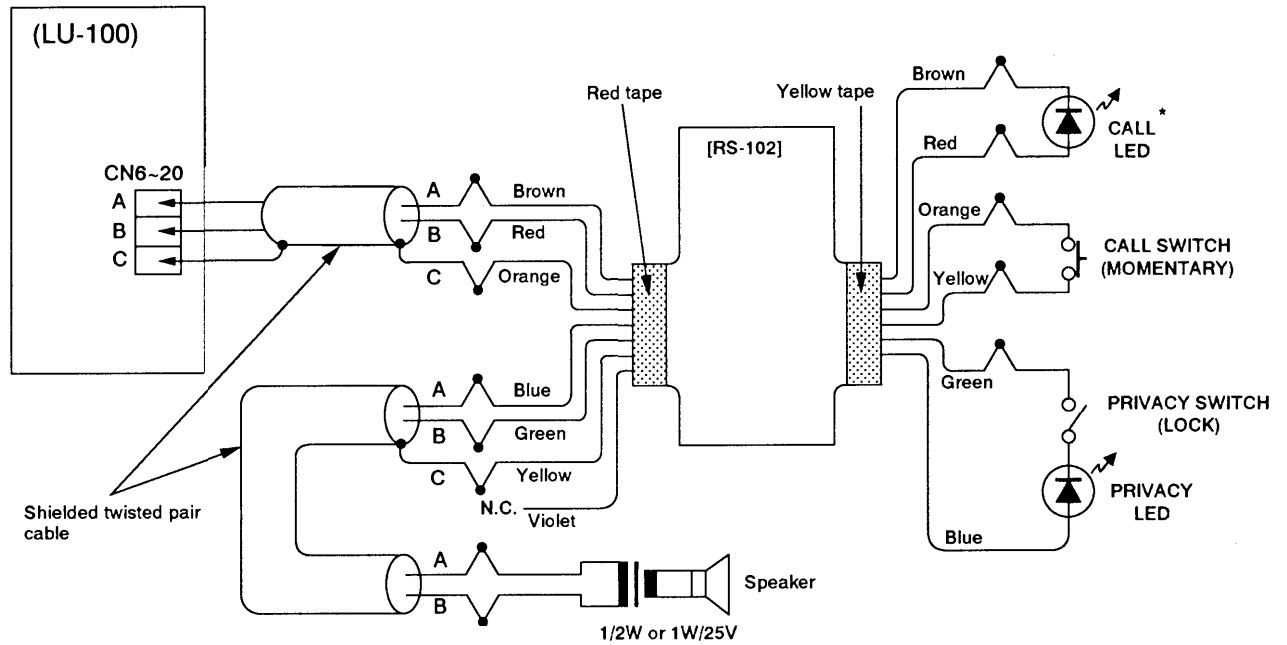

**[Note]** : When not using a CALL LED, short the yellow taped, brown and red leads together.

(6.2) When using the sub-station handset (Room station handset)

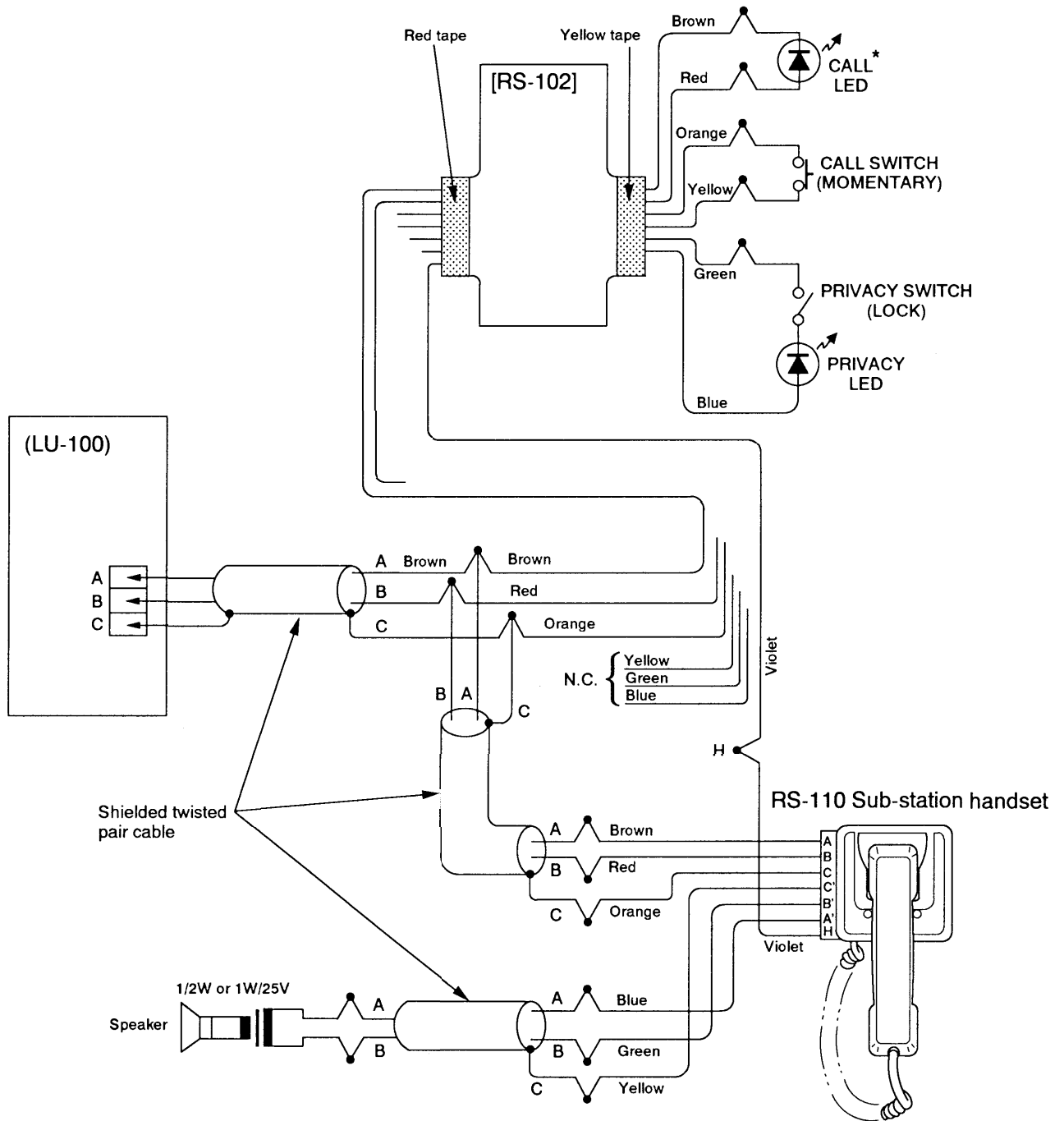

\* [Note] : When not using a CALL LED, short the yellow taped, brown and red leads together.

#### 4.4 CT-100 C/O & Tie-Line Card Connection

##### (1) Tie-Line Interface Connection

A maximum of 9 exchanges can be tie-line interconnected using the CT-100 card. Interconnect the CT-100 cards of each exchange system as shown below.

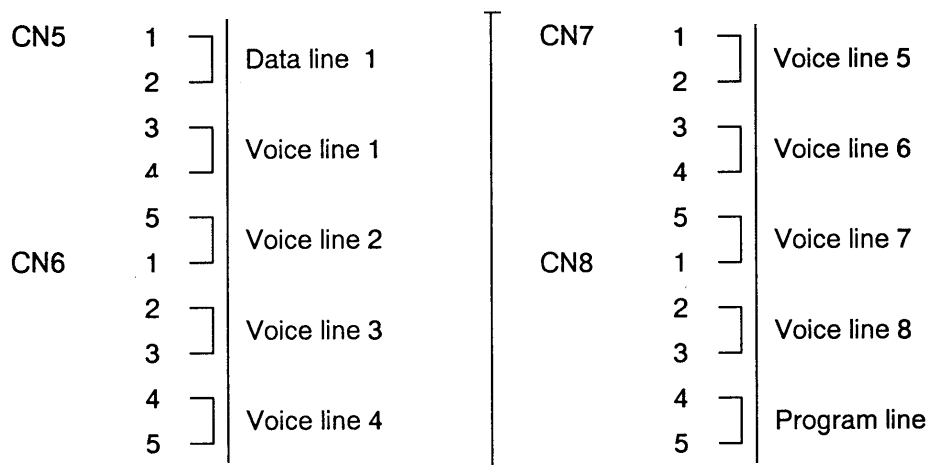

- Be sure to connect Data line 1.
- Relationship between Voice line number and Tie-line link number designated by system programming is shown below. Connect the Voice lines between exchanges corresponding to the employed Tie-line links.

**[Note]** : Be sure to use twisted pair cables for connection.

Tie-line link No.1	—	Voice line 1
	—	Voice line 5
Tie-line link No.2	—	Voice line 2
	—	Voice line 6
Tie-line link No.3	—	Voice line 3
	—	Voice line 7
Tie-line link No.4	—	Voice line 4
	—	Voice line 8

- Program line can be connected if the same program source is to be used for the entire tie-line system. In this case, the JP jumpers on the MU-110 cards on all the exchanges must be cut, except the exchange connected to the program source equipment.
- The JP1 jumpers on the CT-100 cards on all the exchanges must be cut, except the JP1 jumper of the first exchange.

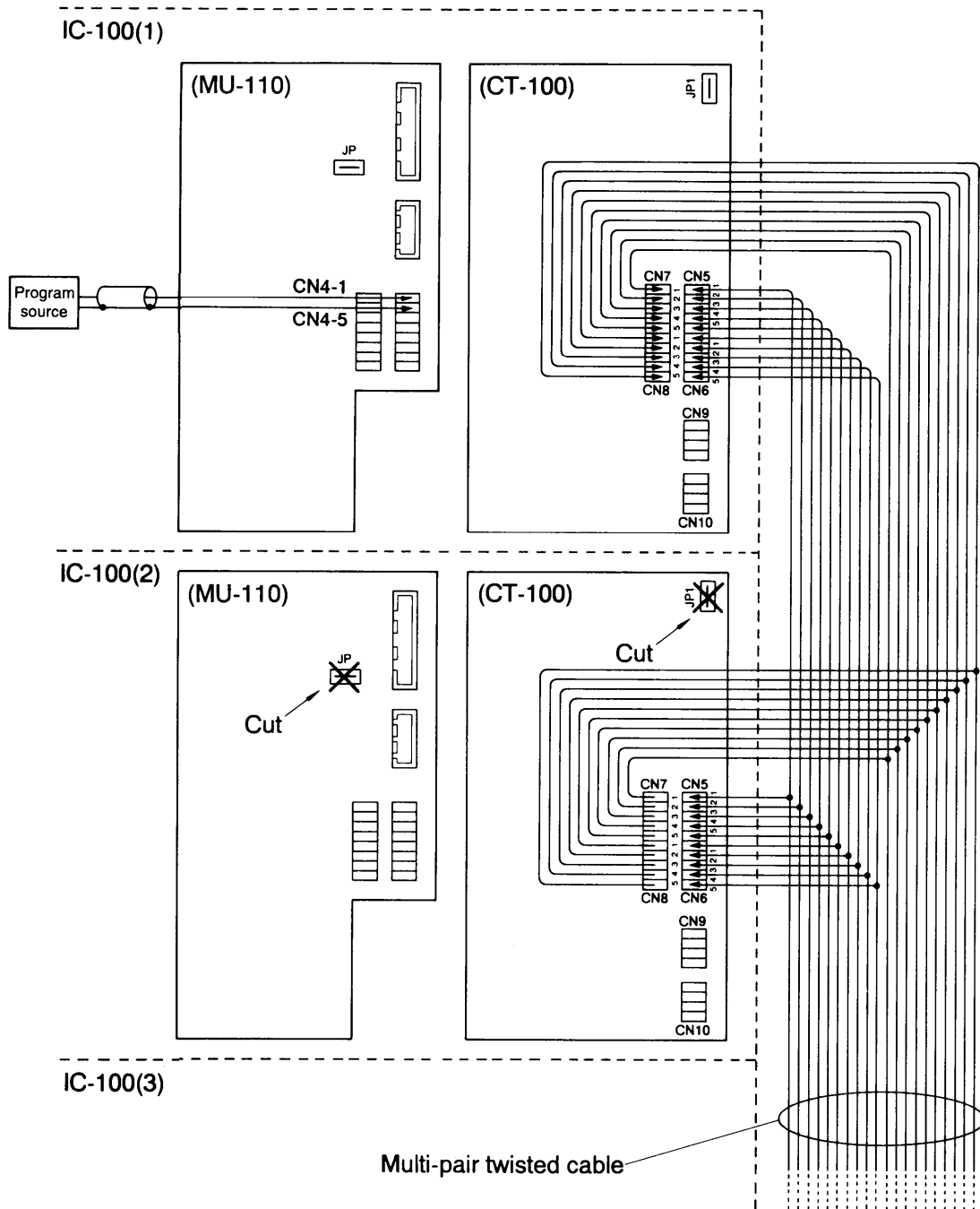



**(2) C/O Line and PBX Extension Connection**

The CT-100 can be interfaced with up to two outside (C/O) telephone lines. Using DTMF tone dialing, it is compatible with both loop and ground start systems. Connect as shown below.

CN9 & 10	1 T	} C/O Line
	2 R	
	3 GND (*1)	
	4 GND	

- Either of two outside lines, Lines No. 1 (CN9) and No. 2 (CN10), can be connected to the PBX extension. To do this, the outside line registration under Function Code 56 must be performed.

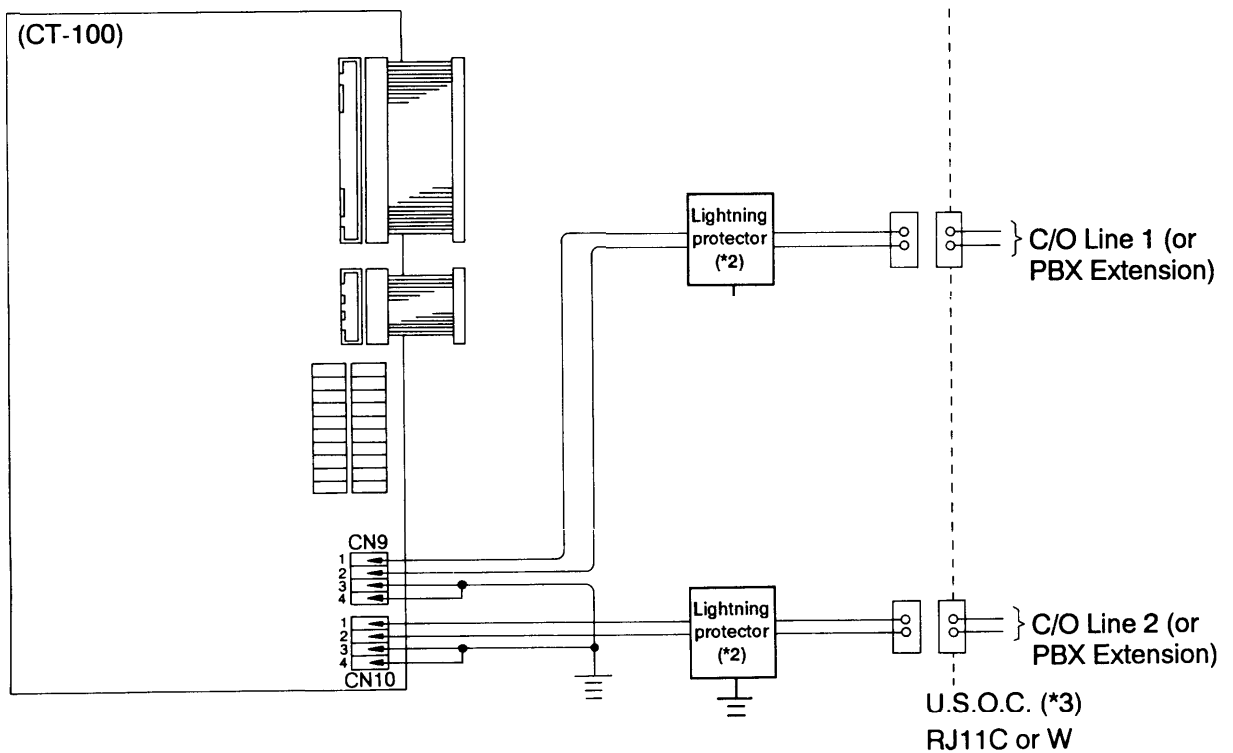

(\*1) Connect only when using ground start.

(\*2) Install a protector if not already installed by the telephone company.

(\*3) This terminal must be installed by the telephone company.

## 4.5 PS-100 Power Supply Card Connection

The PS-100 is supplied with one DC and four AC inputs. Connect as shown below.

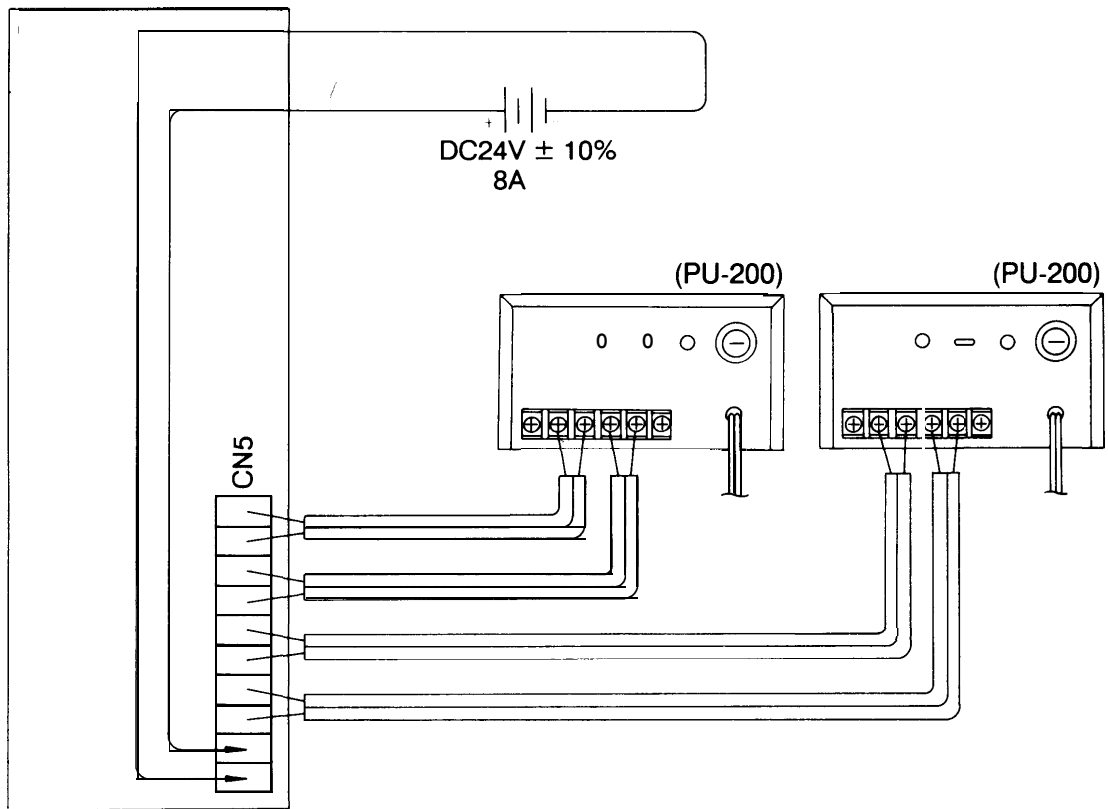

Refer to the illustration below for connection to CN5.

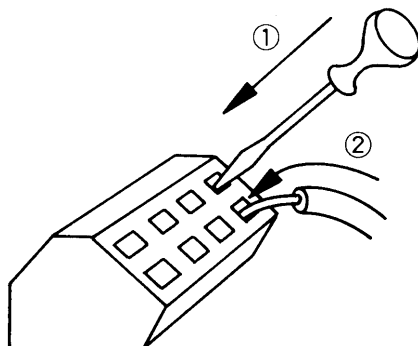

- ① Insert a screwdriver.
- ② Strip the cable and insert the lead into the connector.

## 5. System Programing

### 5.1 Programmable Functions

The IC-100 Institutional Communication System permits programing of a wide range of functions to meet user needs. Read the following explanations and complete the System Configuration Tables before commencement of programing.

#### <Function Group : S>

##### (1) Exchange Number [Function Code 01]

Individual exchange numbers must be assigned to each connected exchange in a tie-line system.

#### <Function Group : A>

##### (2) Station Digit Number [Function Code 11]

A 2-,3-, or 4-digit number can be selected for station numbering. Note that a 2-digit number cannot be used in tie-line systems.

##### (3) Paging Pre-Announcement Tone [Function Code 12]

A paging pre-announcement tone can be set for either a 4-note chime or brief single tone.

##### (4) Speed Dialing Digit Number [Function Code 13]

Select the number of digits (single or double digit), and designate the first digit (0 through 9).

##### (5) Zone Digit Number [Function Code 14]

Select either single (No.1 -9) or double digit (No.01 -60) zones for paging, time signal, and program outputs. (Note that zone No.60 is also used for broadcasting time signals to all zones under the "time schedule" and "external time signal trigger" functions, making the virtually available number of paging zones 59 for a double-digit system.)

##### (6) Westminster Chime Tempo [Function Code 15]

The speed of the Westminster chime used as a time signal source can be adjusted to one of five settings.

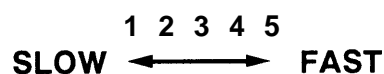

##### (7) Time Signal Source and External Bell Control [Function Code 16]

(a) A time signal can be sounded from seven selectable sources:

1. Internal sound source

1-1 Westminster chime - Long

1-2 Westminster chime - Medium

1-3 Westminster chime - Short

1-4 Trill tone

2. External sound sources 1,2, and 3

(b) External bell control can be set "ON" or "OFF".

The external bell can also be sounded alone, without using the sound source.

##### (8) Time Signal Source Duration Control [Function Code 17]

The output duration of a trill tone, external source signal (1, 2, or 3) and external bell can be set for 1-99 seconds. If Westminster chime is selected, the duration of the external bell is made the same as that of the Westminster chime

**(9) Paging Power Remote Delay [Function Code 18]**

Input to the paging amplifier can be delayed approximately 1 second to avoid sound losses caused by amplifier risetime delays when switched on.

**(10) Duress Alarm [Function Code 19]**

This handset-activated time-delay emergency function may be enabled for the entire system.

**<Function Group : B>**

**(11) Time Schedule [Function Code 21]**

Eight (A-H) 32-step time schedules can be programmed into the internal clock.

Up to nine time signal combination zones of nine or 60 individual zones, time signal source or external bell control can be independently selected for every step.

Note : <Simultaneous time signal output to ten or more individual zones>

To send a time signal to ten or more individual zones simultaneously, provisional zones must be established for programming combinations of such zones under "Station Zone Assignment" [Function Code 41]. The number of available individual zones (Max. 60) decreases for the number of provisional zones established. (Example. If zone No.60 is used as a provisional zone for simultaneous output to all zones, available individual zones are No.1 through No.59.)

**(12) Alert Tone Interval [Function Code 22]**

An alert tone can be transmitted to all in-use sub-stations at a variable interval of 10-990 seconds (in 10-second steps).

**(13) Conversation Time-Out [Function Code 23]**

Conversation time can be restricted to 10-990 seconds (in 10-second steps).

**(14) Calling Time-Out [Function Code 24]**

Call tone duration can be set for 10-990 seconds (in 10-second steps).

**(15) Paging Time-Out [Function Code 25]**

Paging can be automatically terminated following a variable interval of 10-990 seconds (in 10-second steps), in case manual paging termination has been forgotten.

**(16) PBX Conversation Time-Out [Function Code 26]**

PBX-to-system station communication can also be automatically terminated following a variable interval of 10-990 seconds (in 10-second steps).

**<Function Group : C>**

**(17) Station Numbering [Function Code 31]**

Station Nos. can be assigned 2-digit (00-99), 3-digit (000-999), or 4-digit (0000-9999) designations. In tie-line systems, the first station No. represents the station's exchange assignment, and is set under< Function Group: F>.

**Note:** The number of the fixed line leading to a station (as opposed to that of the station itself) is referred to as the "Station Line No." Station Line Nos. are used only in programming operations.

**(18) Station Type and Priority Level [Function Code 32]**

Four different types of stations can be selected:

- (a) Station without handset:  
Sub-station consisting of only switch panel and remote speaker.
- (b) Station with handset:  
Combination of switch panel, sub-station handset and remote speaker.
- (c) Control station with unrestricted function access:  
Control station with access to all available functions.
- (d) Control station with restricted function access:  
Control station with Variable Priority setting, Time Schedule selection, and time change functions disabled.

The sub-station's Fixed Priority can be set for "ALARM", "NORMAL", or "STAFF".

**(19) Sub-Station/Control Station Designation [Function Code 33]**

Any control station in a single or tie-line system can be designated as the called control station when a sub-station call button is pressed.

**(20) Sub-Station/PBX Station Provisional Number Designation [Function Code 33]**

The sub-station can be connected directly to a designated PBX station when its handset is lifted or its [CALL] key is pressed. Provisional PBX station numbers (No.1 -8) must be registered beforehand, and their relationships to corresponding PBX station numbers established under <Function Group E> [Function Code 58].

**[Note]** : This function cannot be used if the sub-station's exchange has no CT-100 card.

**(21) Emergency Call [Function Code 34]**

This function can be independently enabled or disabled for each sub-station.

**<Function Group D>**

**(22) Station Zone Assignment [Function Code 41]**

Up to nine (single digit) or 60 (double digit) individual broadcast zones can be established for paging, time signal, and program source. Arbitrary stations can be assigned to each zone at random, regardless of whether they are connected to different exchanges or the same station number is assigned to multiple zones.

The maximum number of broadcast zones that can be established within a tie-line system is also nine or 60. Register the zone number to be assigned to each exchange under <Function Group F> [Function Code 62].

**[Note]** : Zone No. 60 does not function as an individual zone because it is used for all-zone time signal broadcast. Refer to Section (5) Zone digit number.

**[Example]**

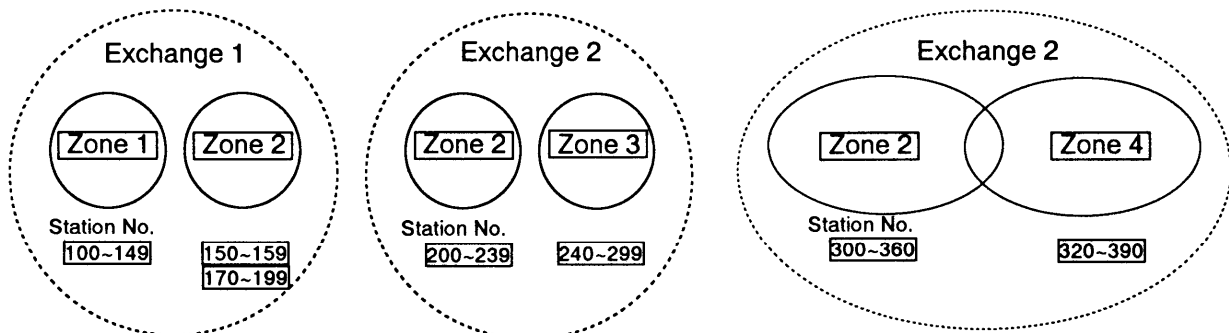

**(23) Combination Zones [Function Code 42]**

Any arbitrary zones in a single-exchange or tie-line system can be combined into one of up to nine combination zones.

**[Example]**

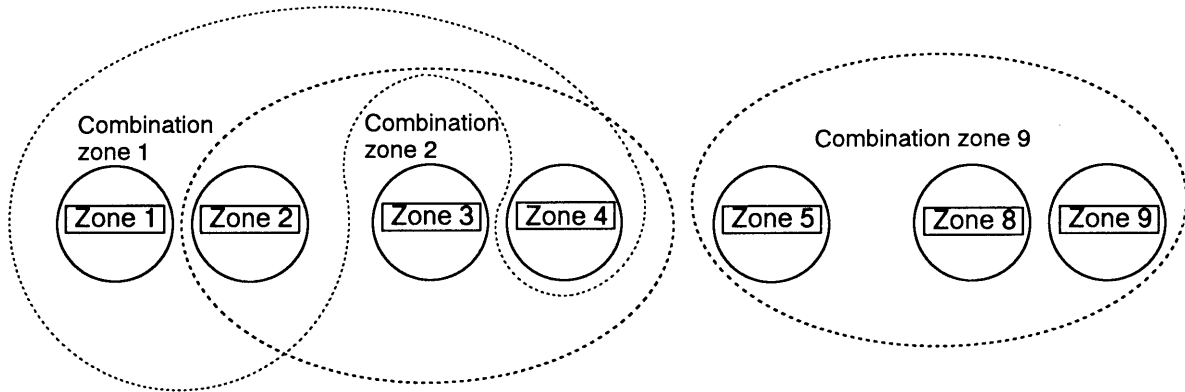

**(24) PA Paging Zone Assignment [Function Code 43]**

All-call, zone, and combination paging dialing operations can be assigned to each of three, 2-bit selectable PA zone outputs.

**(25) Temporary Station Output Disable [Function Code 44]**

Individual stations can be temporarily designated not to receive control station paging (time signal, program source) output. This function has three selectable modes ;

- (a) Total Output Disable  
Totally omits stations from their assigned broadcast zones, with no access to outputs from any control station in the system.
- (b) Limited Output Disable (Without automatic reset)  
Omits stations from their registered control station output.  
Output from other control stations can still be received. (Remains in effect until cancelled by a dialing operation.)
- (c) Limited Output Disable (With automatic reset)  
Omits stations from their registered control station output  
Output from other control stations can still be received, (Automatically cancelled with voice or signal tone transmission.)

**<Function Group : E>**

**(26) External Time Signal Trigger [Function Code 51]**

Time signal transmission can be activated by the external trigger sources such as a switch or timer. Six external trigger inputs are made available, with up to nine combination of nine or 60 zones assignable to each trigger input. Sound source and external bell control settings can also be determined for each external trigger input.

**Note :** Refer to note on (11) Time Schedule [Function Code 21 ].

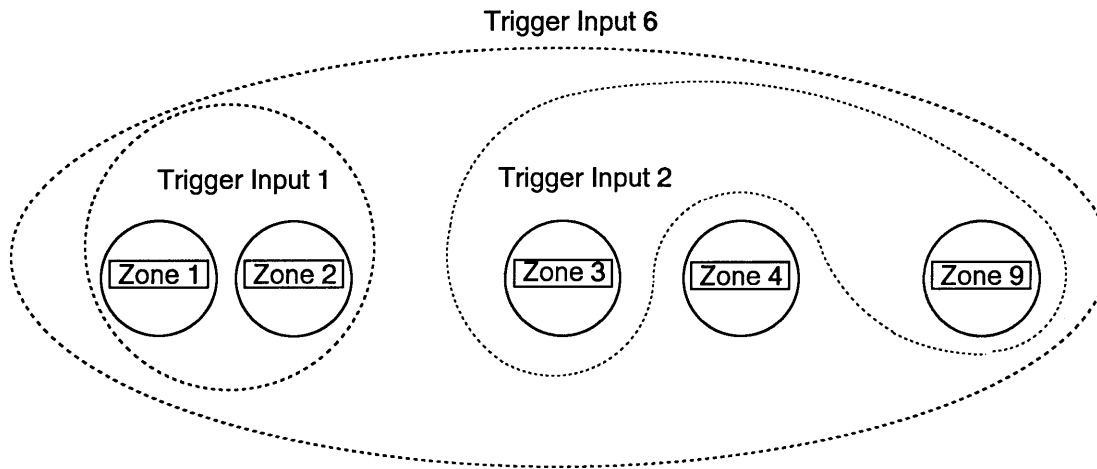

**(27) Outgoing C/O (Telephone) Line Access [Function Code 52]**

The outside and control station line numbers of an exchange can be registered to provide access to outside C/O lines for outgoing calls.

**(28) Incoming C/O (Telephone) Call Access [Function Code 53]**

Control station line numbers can be registered to receive incoming outside calls. Up to eight station line numbers on an exchange can be registered per outside line.

**(29) Auto-Call C/O Transfer [Function Code 54]**

This function permits handset sub-station calls to be automatically forwarded to a programmed C/O telephone number when the corresponding control station is registered for this function. Auto-call C/O transfer telephone numbers must be pre-programmed for this system.

**(30) Control Station Group Call [Function Code 55]**

Control stations for the same group can be simultaneously called from a sub-station. Up to eight control station group calls can be pre-programmed.

**(31) Outside C/O Line and PBX Extension [Function Code 56]**

Each exchange features two outside line terminals which can be registered for either C/O line or PBX extension use. Only one outside line may be connected to the PBX extension. Following PBX extension registration, the PBX stations can be registered for "Restricted" or "Unrestricted" functions.

**(32) External Control Input Function Selection (CN7-1, CN7-2) [Function Code 57]**

External control input terminals CN7-1 & CN7-2 can be set for either "Time signal trigger 5 & 6" or "Control station No.15 (AS1) & No. 31 (AS2) auto-call C/O transfer".

**(33) PBX Station Provisional Numbers and PBX Station Numbers [Function Code 58]**

PBX station provisional numbers (No.1-8) can be assigned PBX station numbers to actually be called. Provisional station numbers are determined with function code 33.

**<Function Group : F>**

**(34) First Station No. Exchange Registration [Function Code 61]**

In a single-exchange or tie-line system, the prefix number assigned to an exchange dictates the first station number and grouping of its assigned station numbers.

**[Example]**

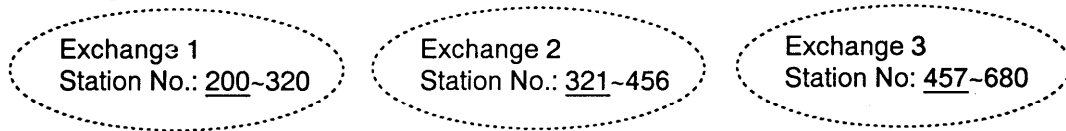

**(35) Exchange Zone Assignment [Function Code 62]**

Individual zone numbers can be assigned to each exchange in a tie-line system. The same zone number can be assigned to several exchanges in the same system.

**[Example]**

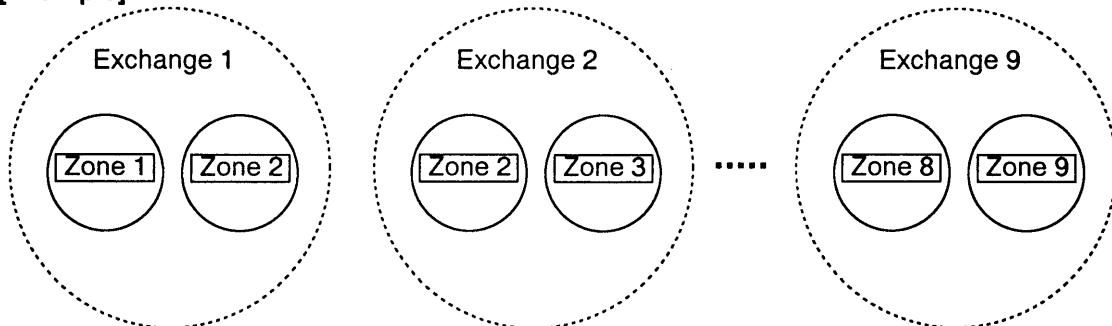

**(36) Tie-Line Link [Function Code 63]**

The tie-line links (1-4) to be used in a tie-line system must be registered.

**<Function Group: H >**

**(37) Speed Dialing Memory Deletion [Function Code 81]**

All speed dialing memory data can be deleted.

**(38) Call Forwarding Memory Deletion [Function Code 82]**

Call Forwarding data and auto-call C/O transfer are returned to initial status.

**(39) Time Setting [Function Code 83]**

The internal clock's time and hour designation (12hr or 24hr), as well as the day of the week can be set.

**(40) Time Schedule [Function Code 84]**

"A-H" or "No schedule" time schedules can be designated.

**<Function Group : I >**

**(41) Password [Function Code 99]**

A 4-digit password can be assigned to restrict entry to the system programming mode, thus protecting the registered system programming data. No password is assigned when the system is shipped from the factory.



## 5.2 Programing Operation

### (1) Programing Mode Entry

\* Tie-line systems require the programing operation in this section to be performed for all exchanges.

KEY OPERATION	DISPLAY
① Set the [REGISTER] switch of the control station corresponding to Station Line No. 15 (connected to the first LU-100) to ON.	Prog mode
② Press the [PUSH TO TALK] key.	St. addr 1
③ Dial [1] if the control station's address is not 1.	
④ Press the [PUSH TO TALK] key.	*

The display changes as shown at right, indicating that the control station is in the programing mode.

### (2) Function Reset

To reset a function group to its initial settings, depress the [ \* ] key and enter the group's function code followed by the [C/#] and [PUSH TO TALK] keys. A confirmation tone will then sound to indicate reset completion.

#### ① Exchange number settings

##### (A) For "Single-exchange system"

\* 0 0 C/# PUSH TO TALK

Confirmation tone

( Function Group "S" reset for Single-exchange system )

##### (B) For "Tie-line system"

\* 0 1 X Y

Total Exchange Nos.

Exchange No.

Confirmation tone

( Function Group "S" reset for Tie-line system )

② \* 1 0 C/# PUSH TO TALK

Confirmation tone

(Function Group "A" reset.)

③ \* 2 0 C/# PUSH TO TALK

Confirmation tone

(Function Group "B" reset.)

④ \* 3 0 C/# PUSH TO TALK

Confirmation tone

(Function Group "C" reset.)

⑤ \* 4 0 C/# PUSH TO TALK

Confirmation tone

(Function Group "D" reset.)

⑥ \* 5 0 C/# PUSH TO TALK

Confirmation tone

(Function Group "E" reset.)

⑦ \* 6 0 C/# PUSH TO TALK

Confirmation tone

(Function Group "F" reset.)

⑧ \* 7 0 C/# PUSH TO TALK

Confirmation tone

(Function Group "G" reset.)

⑨ \* 8 0 C/# PUSH TO TALK

Confirmation tone

(Function Group "H" reset.)

⑩ \* 9 9 C/# PUSH TO TALK

Confirmation tone

(Function Group "I" reset.)

To reset an individual function:

⑪ \* X Y C/# PUSH TO TALK

Confirmation tone

(Designated function reset.)

Function Code

X : 0-9

Y : 1-9

### (3) Function Registration

Function Group	Function	Function Code	Key Operation	Initial Setting <sup>*1</sup>
<b>S</b>	Exchange Number	0 1	1. Single-exchange system : * 0 1 1 2. Tie-line system : * 0 1 X Y X : Total exchange numbers Y : Exchange No.	Single-exchange system
<b>A</b> <sup>*3</sup>	Station Digit Number	1 1	* 1 1 <input type="text"/> 2:2 digits 3:3 digits 4:4 digits	3 digits
	Paging Pre-Announcement Tone	1 2	* 1 2 <input type="text"/> 1 : 4-note chime 2: Single tone	4-note chime
	Speed Dialing	1 3	* 1 3 <input type="text"/> <input type="text"/> 1:1-digit dialing 1st digit No :0-9 2: 2-digit dialing	Disabled
	Zone Digit Number	1 4	* 1 4 <input type="text"/> 1:1 digit (Zone No.1 -9) 2:2 digits (Zone No,O1 -60)	1 digit
	Westminster Chime Tempo	1 5	* 1 5 <input type="text"/> 1-5 1 : Slow, 5: Fast	3
	Time Signal Source and External Bell Control	1 6	* 1 6 <input type="text"/> <input type="text"/> Sound source : External bell control : 0 : No sound source <sup>*1</sup> 0 : OFF 1 : Long Westminster chime 1:ON 2: Medium Westminster chime 3: Short Westminster chime 4: Trill tone 5: External sound source 1 6: External sound source 2 7: External sound source 3 <sup>*1</sup> : Select external bell control [1] when sound source is set to [0].	Sound source: 1 (Long Westminster chime) External bell control : 0(OFF)
	Time Signal Source Duration Control	1 7	* 1 7 <input type="text"/> <input type="text"/> 01-99 sec.	1 sec.
	Paging Power Remote Delay	1 8	* 1 8 <input type="text"/> 0: OFF, 1:ON	Disabled
DuressAlarm	1 9	* 1 9 <input type="text"/> 0: OFF, 1:ON	Disabled	
<b>B</b>	Time Schedule <sup>*4</sup>	2 1	Refer to Section "5.3 Time schedule programing".	—
	Alert Tone Interval <sup>*3</sup>	2 2	* 2 2 <input type="text"/> <input type="text"/> 00-99 00: No alert, 01-99:10-990 sec.	No alert
	Conversation Time-Out <sup>*3</sup>	2 3	* 2 3 <input type="text"/> <input type="text"/> 00-99 00: No limit, 01-99:10-990 sec.	No limit
	Calling Time-Out <sup>*3</sup>	2 4	* 2 4 <input type="text"/> <input type="text"/> 00-99 00: No limit, 01-99:10-990 sec.	No limit

Function Group	Function	Function Code	Key Operation	Initial Setting <sup>*1</sup>
<b>B</b>	Paging Time-Out <sup>*3</sup>	2 5	* 2 5 <input type="text"/> <input type="text"/> 00~99 00: No limit, 01~99:10~990 sec.	No limit
	PBX Conversation Time-Out	2 6	* 2 6 <input type="text"/> <input type="text"/> 00~99 00: No limit, 01~99:10~990 sec.	1 min. (60 sec.)
<b>C</b>	Station Numbering	3 1	1. Single number registration * 3 1 <input type="text"/> <input type="text"/> <input type="text"/> <input type="text"/> Line No. Station No. (000~127) (00-99, 000-999, 0000-9999) 2. Consecutive number registration * 3 1 <input type="text"/> <input type="text"/> <input type="text"/> PUSH TO TALK <input type="text"/> <input type="text"/> <input type="text"/> <input type="text"/> First line No. First station No. Last line No.	<Single-exchange> Station No: 100~27 <Tie-line system> EX1: No.100~199 EX2: No.200~299 EX3: No.300~399 EX9: No.900~999 <sup>*2</sup>
	Station Type and Priority Level	3 2	* 3 2 <input type="text"/> <input type="text"/> <input type="text"/> <input type="text"/> ALL <input type="text"/> Line No. Station type Priority 0 : ALARM 1: NORMAL 2: STAFF Station type: 0 : No station connected. 1 : W/o handset 2: W/handset 4: Unrestricted control station 5: Restricted control station control (* ) No priority level registration required when control station selected.	For sub-station : Station type: W/o handset Priority : NORMAL For control station : Unrestricted control station
	Sub-Station/Control Station Designation	3 3	1. Single number registration * 3 3 <input type="text"/> <input type="text"/> <input type="text"/> <input type="text"/> ( <input type="text"/> * ) <input type="text"/> <input type="text"/> Sub-station Exchange No. Control station line No. line No. (1~9) (015~127) (000~126) 2. Consecutive number registration * 3 3 <input type="text"/> <input type="text"/> <input type="text"/> PTT ( <input type="text"/> * ) <input type="text"/> <input type="text"/> <input type="text"/> <input type="text"/> Sub-station Ex No. Control station Last sub-station line No. (1~9) line No. line No. (* ) Registration only required for tie-line systems,	All sub-stations connected to Line No.15 control station of each Exchange.
Sub-Station/PBX Station Provisional Number Designation	3 3	1. Single number registration * 3 3 <input type="text"/> <input type="text"/> <input type="text"/> ( <input type="text"/> * ) <input type="text"/> <input type="text"/> Sub-station Sub-station PBX station provisional No. line No. exchange No. (128 : No.1) (129 : No.2) (000~126) (1~9) (130 : No.3) (131 : No.4) (132 : No.5) (133 : No.6) (134 : No.7) (135 : No.8) 2. Consecutive number registration * 3 3 <input type="text"/> <input type="text"/> <input type="text"/> PUSH TO TALK ( <input type="text"/> * ) <input type="text"/> <input type="text"/> First sub-station Sub-station PBX station line No. (000~126) exchange No. provisional (1~9) No.(128~135) ... <input type="text"/> <input type="text"/> Last sub-station line No. (000~126) (* ) Registration only required for tie-line systems.	No registration	

Function Group	Function	Function Code	Key Operation	Initial Setting <sup>*1</sup>
C	Emergency Call	3 4	1. Single number registration <input type="text" value="*34"/> <input type="text" value=""/> <input type="text" value=""/> Sub-station 0: OFF line No. (000~126) 1: ON  2. Consecutive number registration <input type="text" value="*34"/> <input type="text" value=""/> <input type="text" value=""/> <input type="text" value=""/> <input type="text" value=""/> <input type="text" value=""/> <input type="text" value=""/> <input type="text" value=""/> First sub-station 0: OFF Last sub-station line No. (000~126) 1: ON line No. (000~126)	Disable
	Registration and Display	3 1 3 2 3 3 3 4 Common	1. Registration and display <input type="text" value="*3X"/> <input type="text" value=""/> <input type="text" value=""/> <input type="text" value=""/> <input type="text" value=""/> <input type="text" value=""/> Line No. Operation ⇒ Displays the registered data of next line number. to register  2. Display only <input type="text" value="*3X"/> <input type="text" value=""/> <input type="text" value=""/> <input type="text" value=""/> <input type="text" value=""/> <input type="text" value=""/> <input type="text" value=""/> <input type="text" value=""/> Line No. DISPLAY CALLS ⇒ Displays the registered data of next line number. X: 1,2,3,4	—
D	Station Zone Assignment	4 1	<input type="text" value="*41"/> <input type="text" value=""/> <input type="text" value=""/> <input type="text" value=""/> <input type="text" value=""/> <input type="text" value=""/> Individual 0: Cancellation First line Last line zone No. 1: Registration No. No. No. (01~60) (000~127) (000~127)  ... <input type="text" value=""/> <input type="text" value=""/> <input type="text" value=""/> <input type="text" value=""/> <input type="text" value=""/> <input type="text" value=""/> 0: Cancellation First line Last line <input type="text" value=""/> <input type="text" value=""/> <input type="text" value=""/> 1: Registration No. No. <input type="text" value=""/> <input type="text" value=""/> <input type="text" value=""/> <input type="text" value=""/> <input type="text" value=""/> <input type="text" value=""/>	No registration
	Combination Zones <sup>*3</sup>	4 2	<input type="text" value="*42"/> <input type="text" value=""/> <input type="text" value=""/> <input type="text" value=""/> <input type="text" value=""/> <input type="text" value=""/> Combination 0: Cancellation First zone Last zone zone No. (1~9) 1: Registration No. (01~60) No. (01~60)  ... <input type="text" value=""/> <input type="text" value=""/> <input type="text" value=""/> <input type="text" value=""/> <input type="text" value=""/> <input type="text" value=""/> 0: Cancellation First zone Last zone <input type="text" value=""/> <input type="text" value=""/> <input type="text" value=""/> 1: Registration No.(01~60) No.(01~60)	No registration
	PA Paging Zone Assignment	4 3	<input type="text" value="*43"/> <input type="text" value=""/> <input type="text" value=""/> PA zone Zone No. (Dial operation) No. (1~3) 00: All-call 01~60: Individual zone 61~69: combination zone No,I-9	No registration
	Temporary Station Output Disable	4 4	<input type="text" value="*44"/> <input type="text" value=""/> 1: Total output disable 2: Limited output disable (Without automatic reset) 3: Limited output disable (With automatic reset)	Total output disable
E	External Time Signal Trigger	5 1	<input type="text" value="*51"/> <input type="text" value=""/> <input type="text" value=""/> <input type="text" value=""/> <input type="text" value=""/> <input type="text" value=""/> Trigger 0: Cancellation First Last input No. (1~6) 1: Registration zone No. zone No. (01~60) (01~60)  ... <input type="text" value=""/> <input type="text" value=""/> <input type="text" value=""/> <input type="text" value=""/> <input type="text" value=""/> <input type="text" value=""/> 0: Cancellation First Last <input type="text" value=""/> <input type="text" value=""/> <input type="text" value=""/> 1: Registration zone No. zone No.	No registration
			Sound source : External bell control 0: No sound source*1 0: OFF 1: Long Westminster chime 1: ON 2: Medium Westminster chime 3: Short Westminster chime 4: Trill tone 6: External sound source 2 5: External sound source 1 7: External sound source 3 *1: Select external bell control [1] when sound source is set to [0].	No registration





### 5.3 Time Schedule Programing

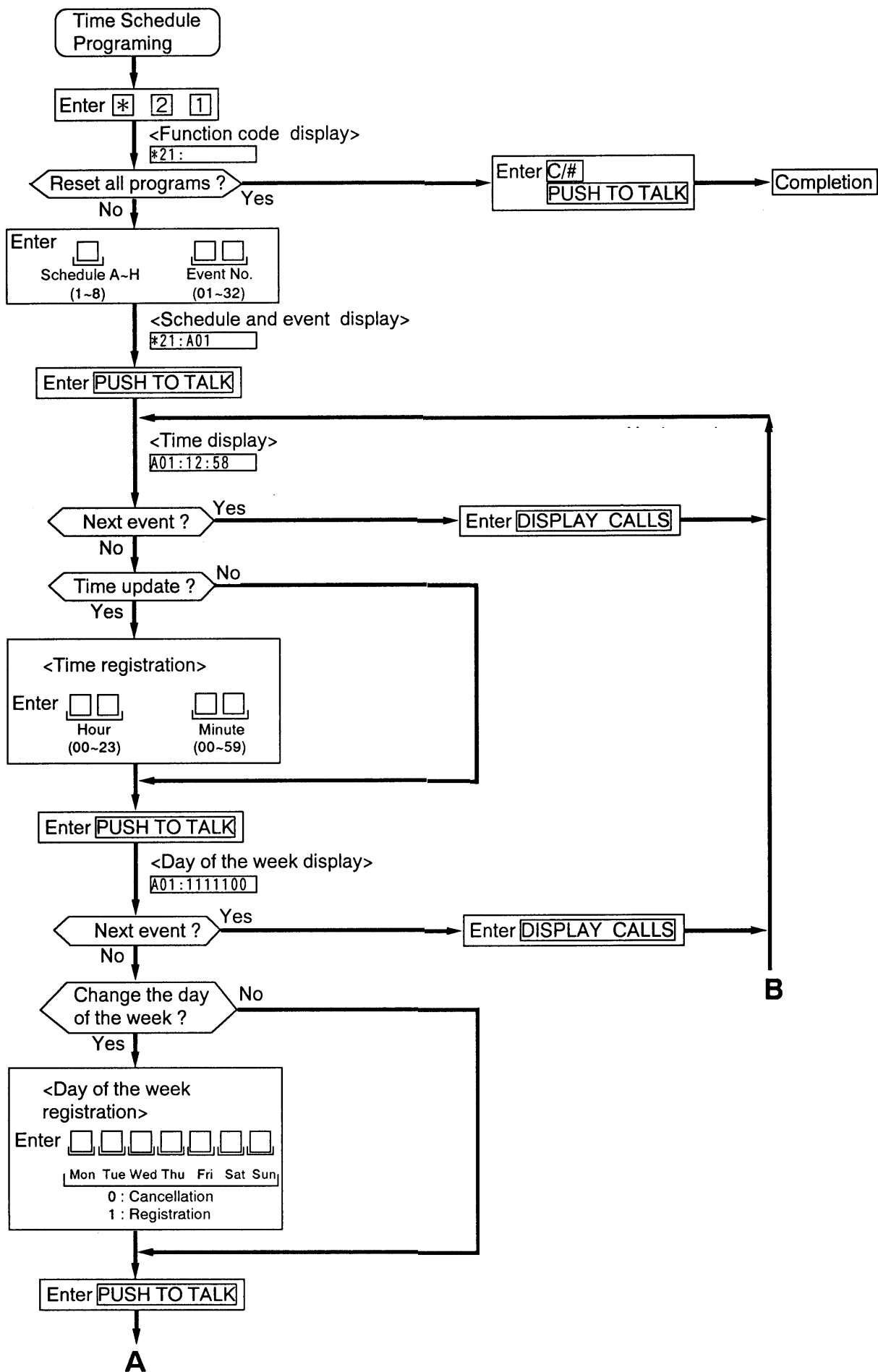

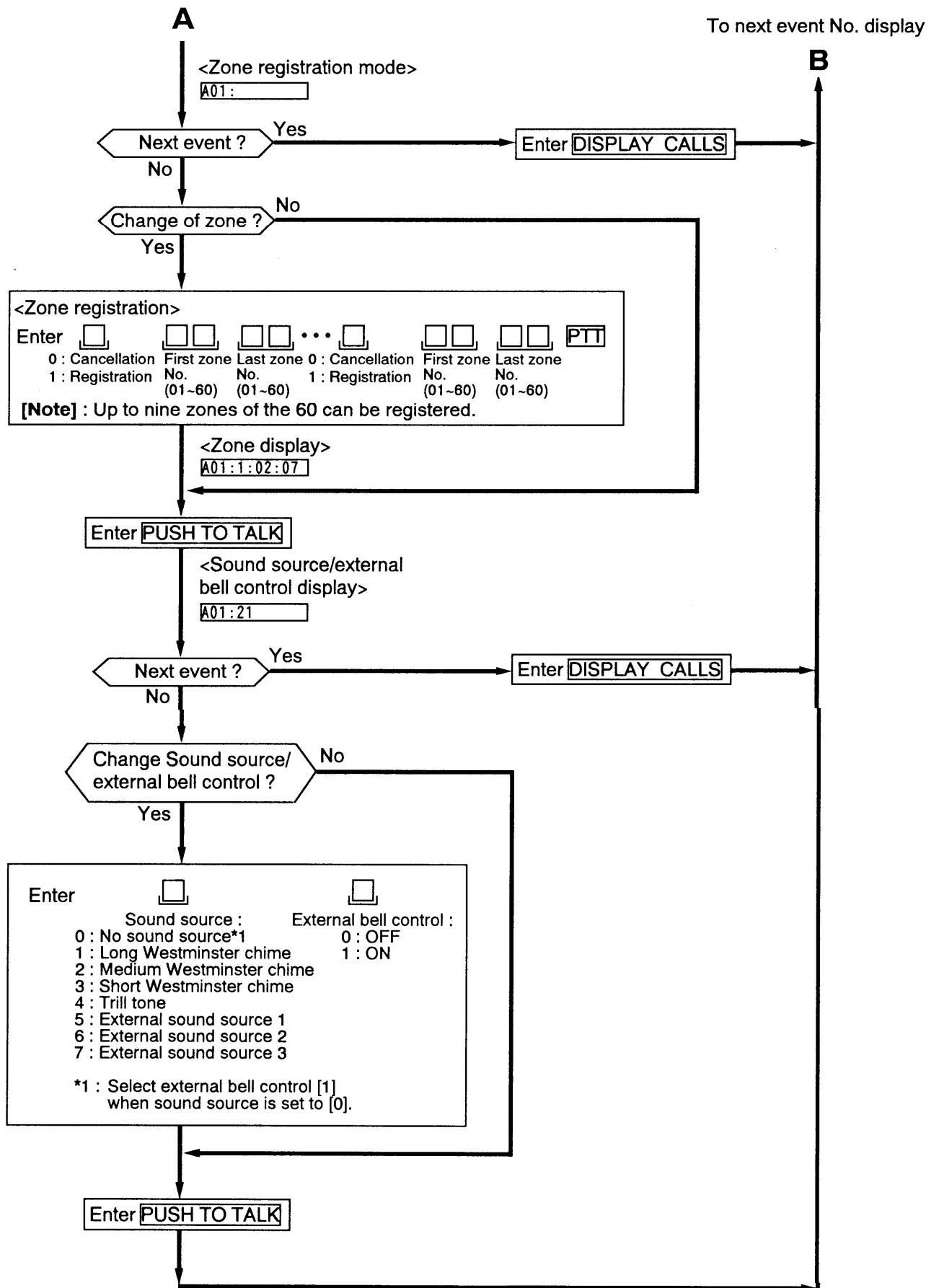



## 5.4 Programing Examples

(1) Register time schedules using the following tables.

Event No.	Time	Day of the week							Zone No. (Max. 9 zones)									Time signal source	External bell control
		Mo	Tu	We	Th	Fr	Sa	Su	①	②	③	④	⑤	⑥	⑦	⑧	⑨		
1	8:45	O	O	O	-	-	-	-	Z1	Z2	-	-	-	-	-	-	-	2	1
2	10:00	O	-	O	O	-	-	O	-	-	Z3	Z4	-	-	-	-	-	2	1
3	11:00	O	O	O	O	O	O	-	Z1	Z2	Z3	Z4	-	-	-	-	-	2	1
4	12:00	O	O	O	O	O	O	O	Z1	Z2	Z3	Z4	Z5	Z6	-	-	-	4	0

### <Example>

To program data of event No.1, follow the procedures below.

#### DIAL OPERATION

#### DISPLAY

①	<input type="text" value="*"/> <input type="text" value="2"/> <input type="text" value="1"/>	<input type="text" value="*21:"/>
②	<input type="text" value="1"/> Schedule A selected.	<input type="text" value="*21:A"/>
③	<input type="text" value="0"/> <input type="text" value="1"/> Event No.01 selected.	<input type="text" value="*21:A01"/>
④	<input type="text" value="PUSH TO TALK"/> Registered time display.	<input type="text" value="A01:12:58"/>
⑤	<input type="text" value="0"/> <input type="text" value="8"/> <input type="text" value="4"/> <input type="text" value="5"/> New time set.	<input type="text" value="A01:08:45"/>
⑥	<input type="text" value="PUSH TO TALK"/> Registered "day of the week" display	<input type="text" value="A01:1111100"/>
⑦	<input type="text" value="1"/> Monday ON	<input type="text" value="A01:1"/>
⑧	<input type="text" value="1"/> Tuesday ON	<input type="text" value="A01:11"/>
⑨	<input type="text" value="1"/> Wednesday ON	<input type="text" value="A01:111"/>
⑩	<input type="text" value="0"/> <input type="text" value="0"/> <input type="text" value="0"/> <input type="text" value="0"/> Thursday - Sunday OFF	<input type="text" value="A01:1110000"/>
⑪	<input type="text" value="PUSH TO TALK"/> To zone registration	<input type="text" value="A01:"/>
⑫	<input type="text" value="1"/> Registration mode selected.	<input type="text" value="A01:1:"/>
⑬	<input type="text" value="0"/> <input type="text" value="1"/> First zone No.01 registered.	<input type="text" value="A01:1:01:"/>
⑭	<input type="text" value="0"/> <input type="text" value="2"/> Last zone No.02 registered.	<input type="text" value="A01:1:01:02"/>
⑮	<input type="text" value="PUSH TO TALK"/> Registered sound source/ external bell control display	<input type="text" value="A01:10"/>
⑯	<input type="text" value="2"/> Medium Westminster chime registered.	<input type="text" value="A01:2"/>
⑰	<input type="text" value="1"/> External bell control ON	<input type="text" value="A01:21"/>
⑱	<input type="text" value="PUSH TO TALK"/> Next event No.02 display	<input type="text" value="A02:"/>

(2) Register the following station numbers.

Station Line No.	Station No.
000	200
001	203
002	210
003	211
004	212
005	213
006	214
007	215

**DIAL OPERATION**

- ① \* 3 1
- ② 0 0 0
- ③ 2 0 0
- ④ 2 0 3
- ⑤ PUSH TO TALK
- ⑥ 2 1 0
- ⑦ 0 0 7

Line No.  
 Station No.  
 Station No.  
 Consecutive No.  
 registration mode  
 First station No.  
 Last line No.

**DISPLAY**

- \*31:
- \*31:000:
- \*31:000:200
- \*31:001
- \*31:001:203
- \*31:002
- 002:
- 002:210
- 007:
- 007:215

(3) Register connected tie-line system control stations and sub-stations.

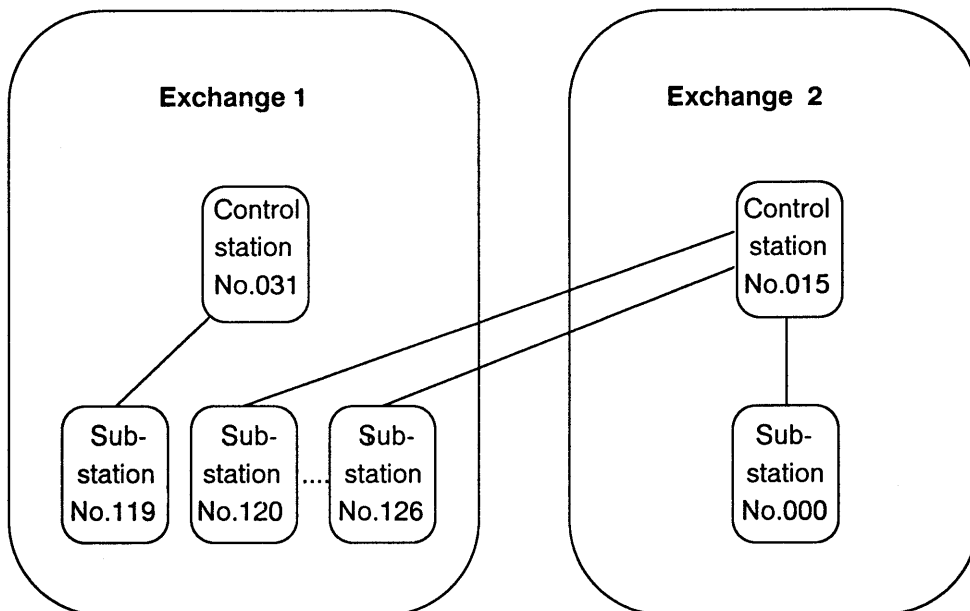

● From Exchange 1, Control station Line No. 15

**DIAL OPERATION**

- ① \* 3 3
- ② 1 1 9
- ③ 1 0 3 1
- ④ PUSH TO TALK
- ⑤ 2 0 1 5
- ⑥ 1 2 6

Sub-station's Line No.  
 Exchange No. and  
 Control station's line No.  
 Consecutive No.  
 registration mode  
 Exchange No. and  
 Control station's line No.  
 Last Sub-station's line No.

**DISPLAY**

- \*33:
- \*33:119:
- \*33:119:1031
- \*33:120
- 120:
- 120:2015
- 126:
- 126:2015

- From Exchange 2, Control station Line No. 15

DIAL OPERATION

- ① \* 3 3
- ② 0 0 0
- ③ 2 0 1 5

Sub-station's Line No.  
Exchange No. and  
Control station's line No.

DISPLAY

*33:
*33:000:
*33:000:2015

- (4) Register the following tie-line system exchange zones.

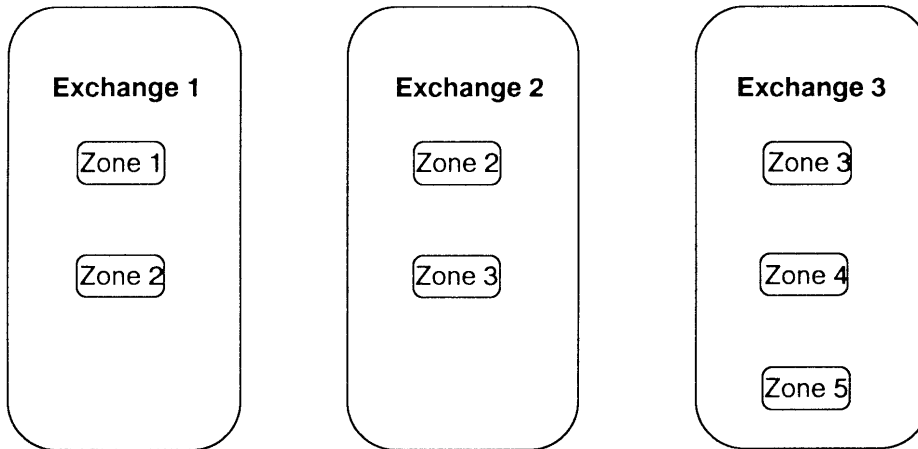

- Program the same data into all the exchanges.

DIAL OPERATION

- ① \* 6 2
- ② 1 Exchange No.1
- ③ 1 Registration mode selected.
- ④ 0 1 First zone No.01
- ⑤ 0 2 Last zone No.02
- ⑥ PUSH TO TALK
- ⑦ 2 Exchange No.2
- ⑧ 1 Registration mode selected.
- ⑨ 0 2 First zone No.02
- ⑩ 0 3 Last zone No.03
- ⑪ PUSH TO TALK
- ⑫ 3 Exchange No.3
- ⑬ 1 Registration mode selected.
- ⑭ 0 3 First zone No.03
- ⑮ 0 5 Last zone No.05
- ⑯ PUSH TO TALK

DISPLAY

*62:
1:
1:1:
1:1:01:
1:1:01:02
*62
2:
2:1:
2:1:02:
2:1:02:03
*62
3:
3:1:
3:1:03:
3:1:03:05
*62

## 5.5 Operating Precautions

- (1) If an error occurs during programing, enter [ \* ] [X] [Y] and restart from the beginning.  
Function  
Code
- (2) No programing can be performed during conversation (or while the in-use indicator lamp remains lit) even if the [REGISTER] switch is turned ON. Enter the programing mode after terminating the conversation.
- (3) All incoming calls to the station in programing mode will be ignored. (Emergency calls can still be displayed.)
- (4) Do not switch power off for at least one minute after programing completion ([REGISTER] switch OFF).
- (5) If an emergency all-call paging is received during programing operation, turn the [REGISTER] switch OFF and restart from the beginning after the emergency all-call paging is terminated.

Perform operation checks from all connected control stations and sub-stations after system programing completion. Be sure to write the test results in the installation registration chart for future reference.

## 6. Operation Check

### 6.1 Voice and Function Tests

#### ● Voice Test

Communicate between the control station and its designated sub-stations, and also between the control station and other control stations to check the sound volume and quality.

Adjust the control station's microphone sensitivity or speaker volume using its semi-fixed volume control.

#### <Test Procedure>

- (1) Call the sub-station from the control station.
- (2) Press the [PUSH TO TALK] key to initiate manual half-duplex conversation.
- (3) Pick up the control station's handset to initiate automatic voice-activated semi-duplex conversation.
- (4) Pick up a sub-station handset to initiate full-duplex conversation.
- (5) Replace both handsets.
- (6) Press the sub-station's [CALL] switch to call the control station.
- (7) Pick up the control station handset for conversation.
- (8) Replace the control station's handset.
- (9) Press the sub-station's [PRIVACY] switch.
- (10) Call the sub-station from the control station.

#### ● Function Test

Referring to the operation manual, check to confirm that the functions to be used operate correctly. Check also for correct system programing, such as paging zone assignment.

## 6.2 Troubleshooting

When troubles occur during installation, refer to the following checklist to determine the cause.

Symptom	Cause
LED does not flash when sub-station's [CALL] switch is pressed.	Improper connection of A- or C-wire.
LED does not light when sub-station's [PRIVACY] switch is pressed.	Improper connection of B- or C-wire.
Emergency call is made to control station without pressing sub-station's [CALL] switch.	Short of A- and C-wires or A-wire and ground.
Station is put in privacy mode without pressing sub-station's [PRIVACY] switch.	Short of B- and C-wires or B-wire and ground.
Emergency call is made when sub-station's [PRIVACY] switch is pressed.	Connection of A- and B-wires reversed.
Sub-station's LED does not light when handset is lifted.	Improper H-wire connection.
No characters on control station LCD.	Improper voice line connection.
Inaccurate time display.	Improper data line connection.
In-use lamp does not light when control station dialed.	Improper setting of LU-card's SW1 or control station numbers.
Noise heard at sub-station when called from control station.	Improper sub-station connection.
No speaker output, although call can be made from sub-station.	B-wire is not connected.
CK-100's front-mounted LED does not flash.	Power cord is not plugged in AC outlet.

## 7. Appendix

### 7.1 Typical Input/Output Application (MU-110 Card)

#### (1) Dry Contact (Non-Voltage Make Contact) Input Example

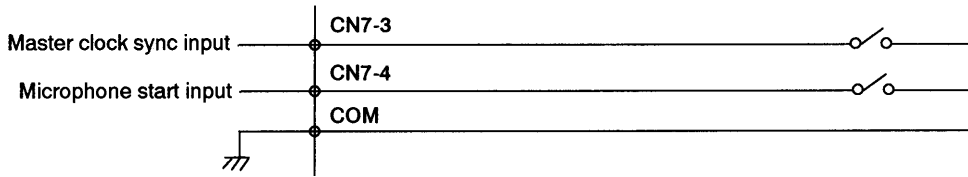

#### (2) Open Collector Output Examples

##### ● Two PA zones

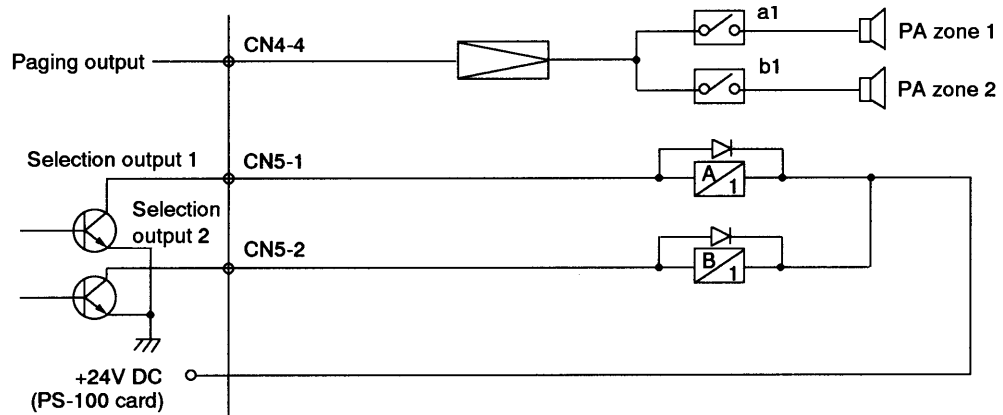

##### ● Three PA zones

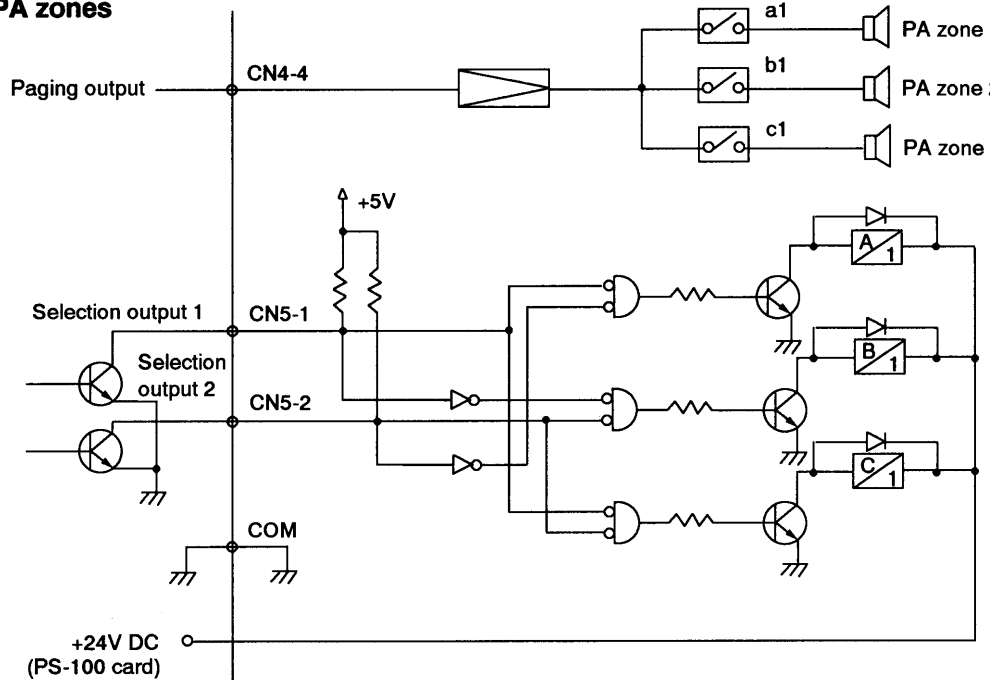

**[Note]** : The PS-100'S power voltage (24V DC) fluctuates from 22V to 30V. When using the PS-100 to supply power to the relay, therefore, care must be given to the relay's operating voltage.

## 7.2 “External PA Paging” Application for Tie-Line Systems

### (1) Simultaneous station and external PA paging output

Perform system programming under “PA paging zone assignment” [Function code 43] to establish the relationship of the station zone to PA zone for the exchange having the station zone assigned under “Exchange zone assignment” [Function code 62]. (The external PA zone must not be assigned to the station zone not assigned to the exchange.)

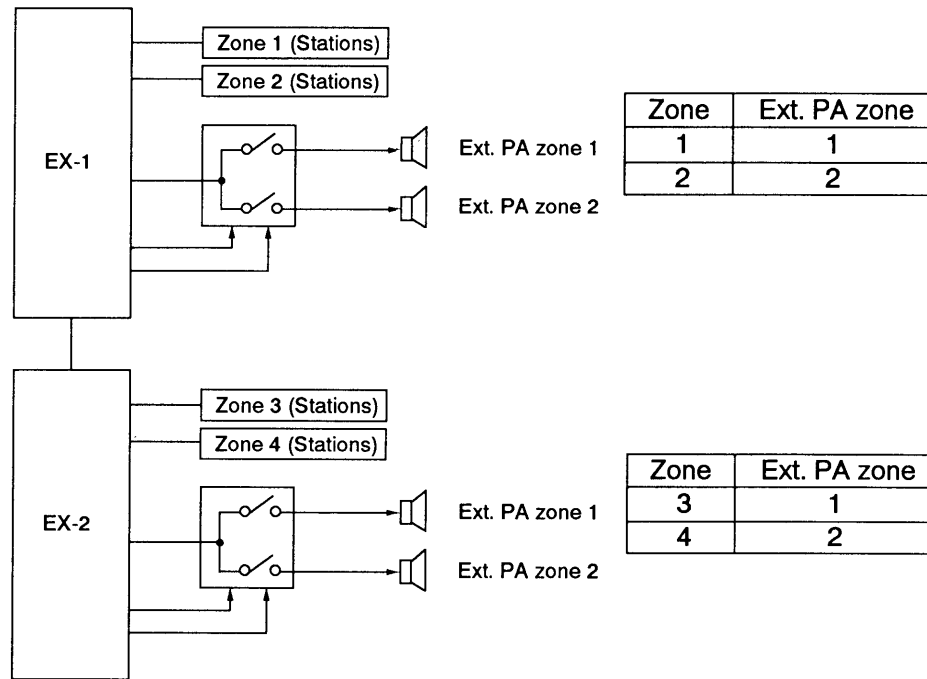

### (2) Independent external PA paging output

Even when broadcasting only external PA paging, the “provisional zone” having no station must be registered under “Exchange zone assignment” [Function code 62].

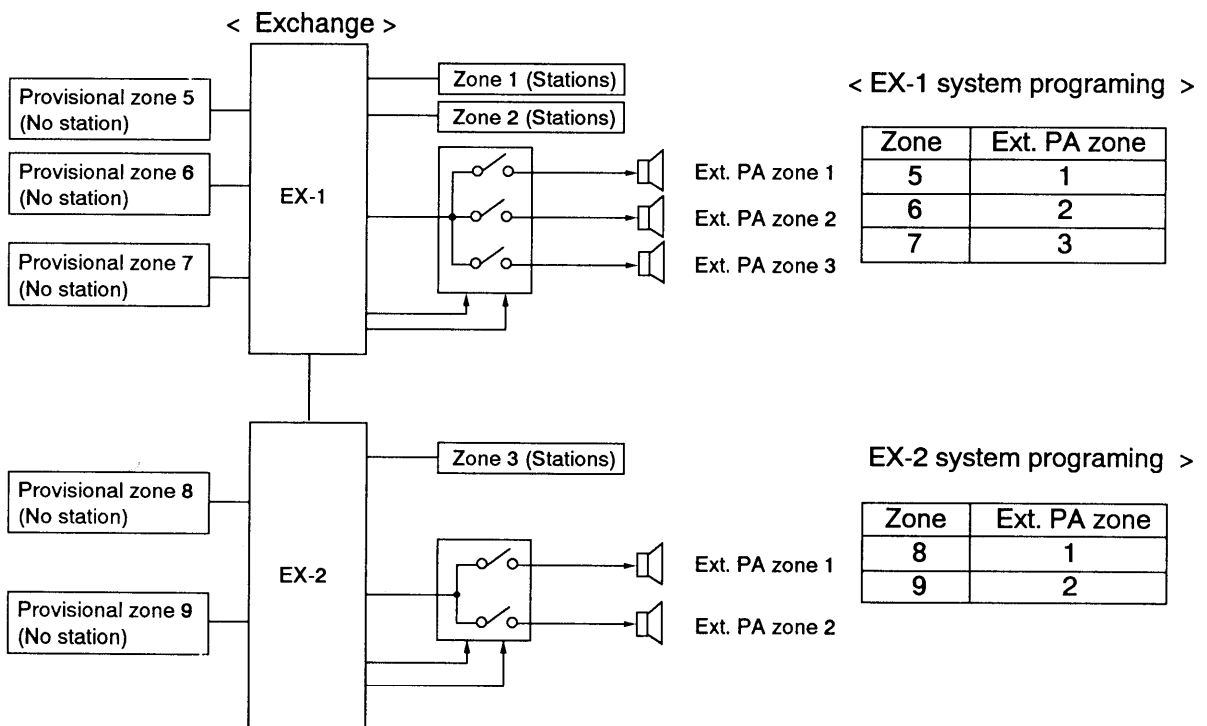



TOA Corporation

E3.1

Printed in Japan  
133-06-179-0E