

TOA NEW 900 SERIES MIXER POWER AMPLIFIER

A-903A
A-906A
A-912A

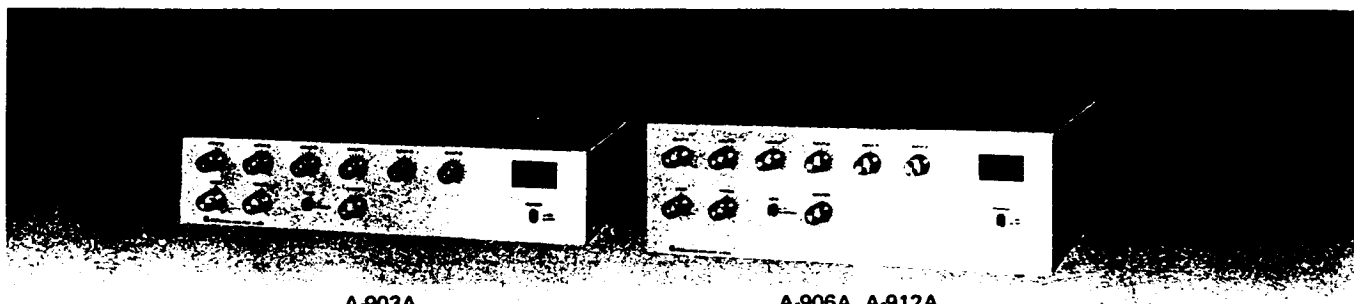

A-903A

A-906A, A-912A

Features

- 1 6-channel mixer power amplifier
- 2 Wide frequency response; 20 – 20,000Hz, ± 1 dB
- 3 Low distortion and noise level
- 4 Excellent output regulation
- 5 Bass and treble controls
- 6 Bridging input/output
- 7 Signal processing input/output
- 8 Self-protecting circuitry design
- 9 Varied output impedances; 4 and 8 ohms, 25 and 70 volts
- 10 A full range of plug-in modules
- 11 Portable or rack-mounting type

General Description

The TOA A-903A, A-906A and A-912A Mixer Power Amplifiers control and mix up to six independent input signals. The A-903A delivers up to 30 watts of output power, the A-906A 60 watts and the A-912A 120 watts. Optional accessory modules are available for use with the A903A, A-906A and A-912A to provide versatility for a wide range of operating applications. Edge connectors on the rear of the unit permit the selection of the TOA plug-in modules: The H-01 series, H-02 series and H-03 series Microphone Preamplifiers, the E-01 and E-11 Mag. Phono Preamplifiers, the X-01 series and X-11 series Auxiliary Preamplifiers for high-level sources, the B-01 series and B-11 series Bridging Transformers for bridging high-impedance lines, the L-01 series Line Matching Transformers for matching 600-ohm lines, I-01 Paging Input for combining with TOA Intercom Systems EXES-1000, EXES-5000 and EX-16, T-01 series Line Outputs for matching 600-ohm lines and the S-01, S-02 and S-03 Tone Signal Generators for generating attention-getting signals and 1 kHz sine wave for testing within the total system. Other features include a muting function. Sources fed to particular input module accessories are muted by short-circuiting at MUTE TERMINALS on the rears. To perform this function, Module E-11, X-11 series or B-11 series is required.

The TOA A-903A, A-906A and A-912A Mixer Power Amplifiers have output terminals to match 4- or 8-ohm speaker systems, or speaker distribution systems may be connected to the 25- or 70-volt terminals. The A-903A, A-906A and A-912A can be rack mounted by using Rack-mounting Bracket accessories MB-921 (for A-903A) or MB-931 (for A-906A and A-912A). The PF-911 Perforated Panel (1.73 inches, 1 rack unit) accessory provides suitable ventilation, finished in color to match the A-903A, A-906A and A-912A.

TOA NEW 900 SERIES

Front Panel Controls and Features

A-903A

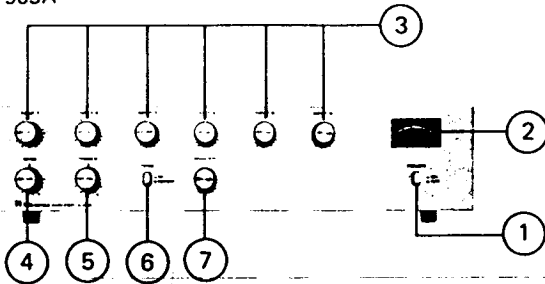

A-906A, A-912A

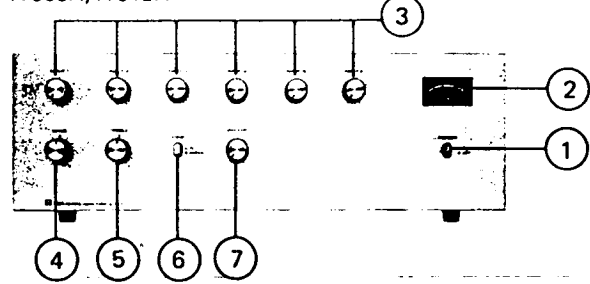

Item	Name	Function/Description
1	POWER ON-OFF SWITCH	Applies line power. Two-position push button switch for on-off modes.
2	METER	Indicates the output level of the amplifier. At rated output, it shows 0 VU (at continuous sine-wave signal input). When power is turned on, meter illuminates.
3	INPUT VOLUME CONTROLS	Adjust gain of INPUT #1 - #6 respectively.
4	BASS CONTROL	Adjusts bass response. Turn clockwise (CW) to boost and counterclockwise (CCW) to attenuate the bass response. Tone is flat at center.
5	TREBLE CONTROL	Adjusts treble response. Turn CW to boost and CCW to attenuate the treble response. Tone is flat at center.
6	TONE SWITCH	Selects IN/DEFEAT of the BASS and TREBLE Controls. When this button is depressed (IN), the BASS and TREBLE Controls are active. (IN) When pressed again (DEF), they become inactive to make tone flat. (TONE DEFEAT)
7	MASTER VOLUME CONTROL	Adjusts overall gain of unit.

Block Diagram

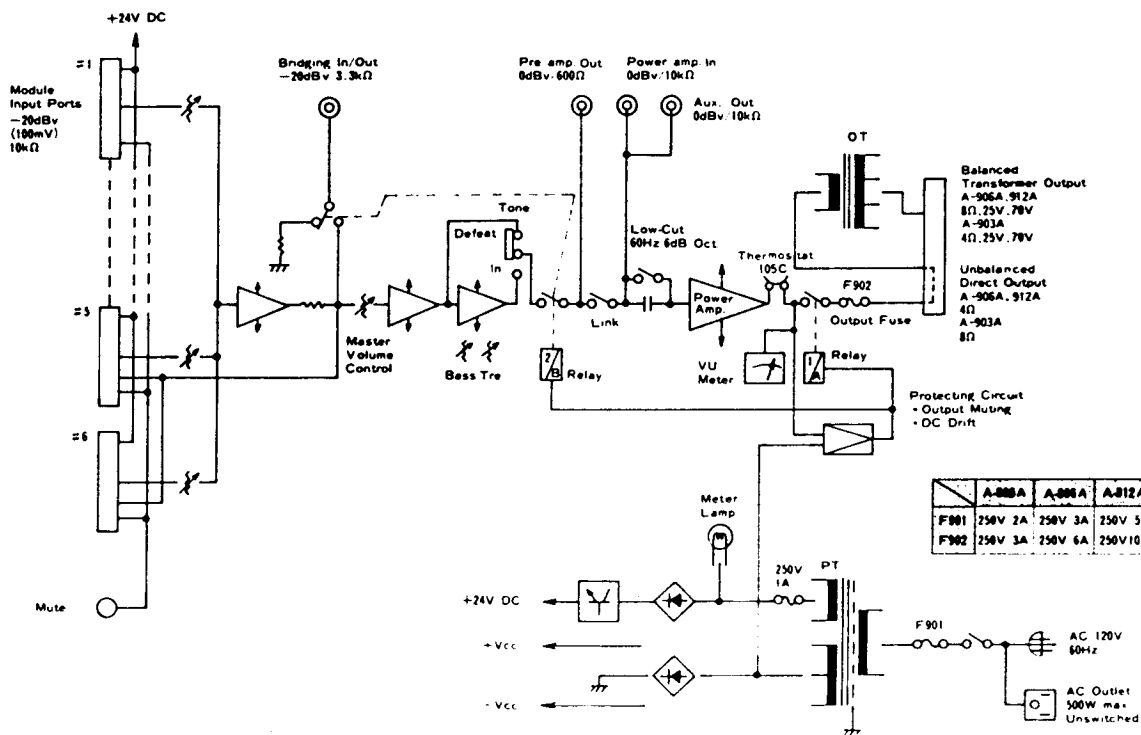

Rear Panel Controls and Features

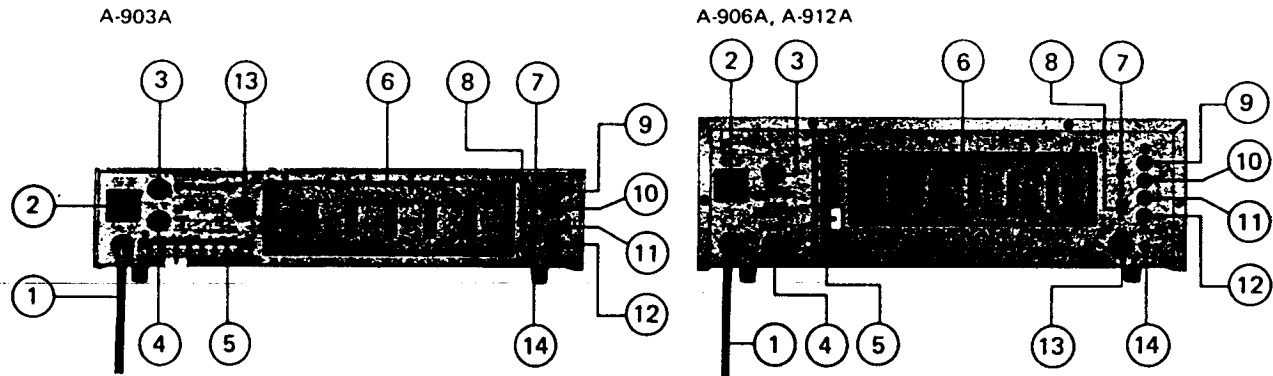

AC POWER SUPPLY CORD	Connects to power source.												
AC OUTLET (Unswitched)	Provides AC power for auxiliary equipment with power consumption of up to 500W.												
AC FUSE OUTPUT FUSE	Prevents excessive current flow. <table border="0"> <tr> <td></td> <td>(A-903A)</td> <td>(A-906A)</td> <td>(A-912A)</td> </tr> <tr> <td>AC FUSE</td> <td>250V 2A</td> <td>250V 3A</td> <td>250V 5A</td> </tr> <tr> <td>OUTPUT FUSE</td> <td>250V 3A</td> <td>250V 6A</td> <td>250V 10A</td> </tr> </table>		(A-903A)	(A-906A)	(A-912A)	AC FUSE	250V 2A	250V 3A	250V 5A	OUTPUT FUSE	250V 3A	250V 6A	250V 10A
	(A-903A)	(A-906A)	(A-912A)										
AC FUSE	250V 2A	250V 3A	250V 5A										
OUTPUT FUSE	250V 3A	250V 6A	250V 10A										
OUTPUT TERMINALS	Connect to speakers.												
MODULE INPUT PORTS	Accept PLUG-IN MODULES which are optionally available. Module selection is determined by application.												
LOW-CUT SWITCH	Cuts off unnecessary low frequency.												
LINK SWITCH	Disconnects between preamplifier and power amplifier when this switch is turned to the "OUT" side, and other equipment can be connected.												
AUX OUT	Provides connections for a booster amplifier or a tape recorder. The input impedances of the equipment should be of more than 10k ohms.												
POWER AMP IN	When using this terminal, set LINK SWITCH to "OUT" position.												
PREAMP OUT	Connects to a signal processing equipment such as a limiter, an equalizer etc. The input impedances of the equipment should be of more than 600 ohms. In this case, the LINK SW should be set in the "OUT" position.												
BRIDGING INPUT/OUTPUT	This terminal is used as a mixing bus. Mixing is achieved when the similar terminal of another amplifier is connected to this terminal. The output level taken from this terminal is independent of the MASTER VOLUME CONTROL, BASS and TREBLE CONTROLS so that the terminal can also be used as recording output. The input impedances of the equipment to be connected here should be of more than 10k ohms.												
MUTE TERMINAL	With modules employing muting function, which are optionally available, the input signals fed to the modules are muted by short-circuiting at this terminal.												
EARTH TERMINAL	Normally connects to a record player's ground.												

TOA NEW 900 SERIES

Input Connections

- This unit has six INPUT PORTS for PLUG-IN MODULES. Select the desired ones for each application.
- Plug the modules into INPUT PORTS, sliding them between the guide rails, and secure each with two screws.

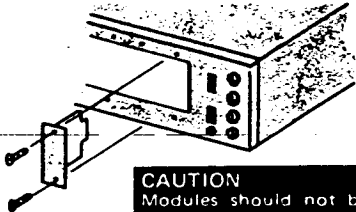

CAUTION
Modules should not be inserted or removed while the amplifier is turned on.

- When not all INPUT PORTS are occupied, cover the vacant PORTS with blank panels, and secure them with screws.
- PLUG-IN MODULES are provided in the following:

Balanced low impedance microphone	H-01, H-21, H-31
premp module (with presettable low-cut filter, high-cut filter and gain controls)	
Balanced low impedance microphone	H-02, H-22, H-32
premp module (with presettable low-cut filter and gain controls)	
Equalized mag. phono preamp. module	E-01, E-11
(with presettable gain control)	
Unbalanced high impedance auxiliary	X-01, X-11, X-21
preamp module (with presettable gain control)	
Balanced 10kΩ bridging transformer module	B-01, B-11
Balanced 600Ω line matching	L-01, L-11, L-41
transformer module	
Balanced paging input module	I-01
(with presettable gain control and MUTE Delay)	
Balanced 600Ω line output module	T-01
(with presettable gain control)	
Signal tone generator module	
(with presettable output level control)	
1kHz sine wave	S-01
Yelp and huzzrr	S-02

Output Connections A-903A

The speaker outputs of the amplifier are 4Ω, 8Ω, 25V (21Ω) and 70V (167Ω).

Connect speakers to one of these outputs.

Class 2 wiring may be used.

Since these outputs consist of 4Ω, 25V and 70V via the output transformer (matching transformer) and direct output of 8Ω, the connecting method differs in each case.

See the following diagrams.

Note: Impedances indicated below imply total speaker system (load) impedances.

- When connecting speakers to any one of the outputs of 4Ω, 25V or 70V (BALANCED TRANSFORMER OUTPUT):

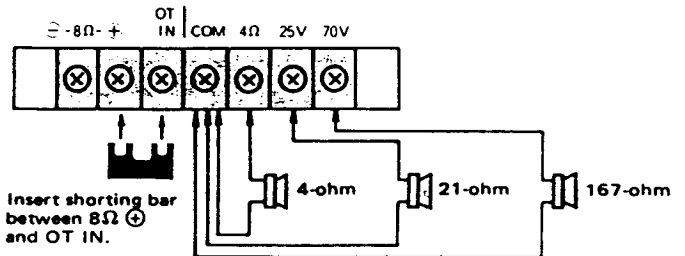

Note:
In this case, the LOW-CUT SWITCH should be in "CUT" position. This amplifier is characteristically flat even in the low frequency range. Therefore, in TRANS OUTPUT, the acoustic effect and frequency-response characteristics may be altered. In TRANS OUTPUT, cut off unnecessary low frequency to obtain the best acoustic condition.

Place the LOW-CUT SWITCH in "CUT" position

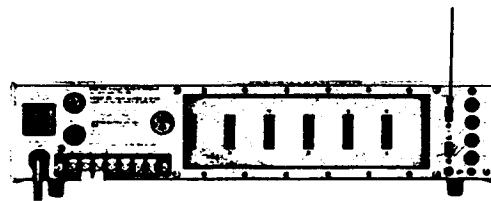

Output Connections A-906A, A-912A

The speaker outputs of the amplifier are 4Ω, 8Ω, 25V and 70V. Connect speakers to one of these outputs. Class 2 wiring may be used.

Since these outputs consist of 8Ω, 25V and 70V via the output transformer (matching transformer) and direct output of 4Ω, the connecting method differs in each case. See the following diagrams:

Note: Impedances indicated below imply total speaker system (load) impedances.

- When connecting speakers to any one of the outputs of 8Ω, 25V or 70V (BALANCED TRANSFORMER OUTPUT):

(A-906A)

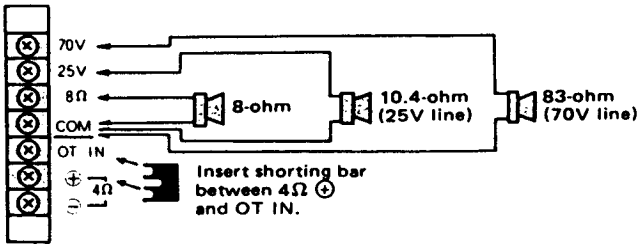

(A-912A)

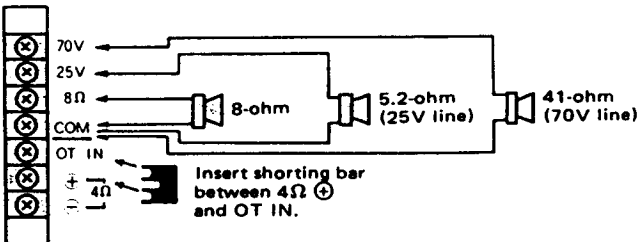

Note:

In this case, the LOW-CUT SWITCH should be in "CUT" position. This amplifier is characteristically flat even in the low frequency range. Therefore, in TRANS OUTPUT, the acoustic effect and frequency-response characteristics may be altered. In TRANS OUTPUT, cut off unnecessary low frequency to obtain the best acoustic condition.

Place the LOW-CUT SWITCH in "CUT" position

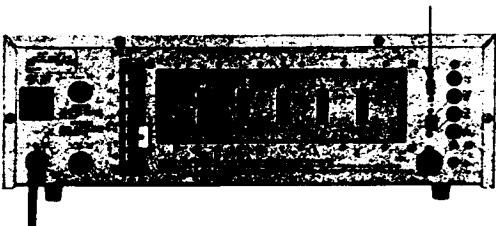

- When connecting speakers to the 4Ω output. (UNBALANCED DIRECT OUTPUT):

(A-906A, A-912A)

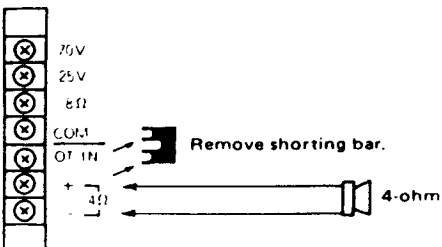

Installation

- Do not block cover ventilation holes.
- The amplifier should not be placed in areas:
 - 1 with poor ventilation.
 - 2 exposed to direct sunlight.
 - 3 with high ambient temperature or adjacent to heat-generating equipment.
 - 4 with high humidity or dust levels.
 - 5 susceptible to vibration.

CAUTION:

Do not remove the case or you may encounter an electric shock.

Note:

When the temperature of heat sink exceeds 105°C, the protection circuit is activated and the output is disconnected from the circuit. The signal automatically begins to be output as the temperature goes down. In such a case, confirm whether or not unit is overloaded or operated on an excessive output.

TOA NEW 900 SERIES

Operation

When all connections are completed, turn power switch on. Then, the meter is illuminated. Approx. 5 seconds after switching power on, the amplifier comes into operation.

ADJUSTMENT OF VOLUME

Adjust the individual input and master volume controls to obtain appropriate output level. In normal use of BGM playing or announcement; the deflection of the meter is recommended to be within the range as indicated in the drawing. Tone quality will be considerably deteriorated if the pointer indicates around 0 VU.



ADJUSTMENT OF TONE QUALITY

When adjusting tone quality, place the TONE SWITCH in "IN" position, thus activating the BASS and TREBLE CONTROLS. Each control provides frequency-response characteristics of flat in center, boost in CW and attenuation in CCW positions.

When tone controls are unnecessary, place the TONE SWITCH in "DEFEAT" mode.

●Output fuse

Each amplifier has an output fuse to protect the amplifier from short-circuiting at the output or overloading. Check the fuse when speakers connected do not sound even if the meter deflects normally. If the fuse blew, replace with the same type fuse after confirming the following points.

- 1 Speaker cables are not short-circuited or the load does not exceed the rating specified.
- 2 Wiring is correctly done at the output terminal board.

Rack Mounting

To mount the amplifier in a standard 19-inch equipment rack, use the MB-921 or MB-931 Rack-mounting Bracket accessory. (OPTION)

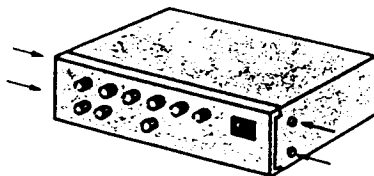

Remove 4 screws securing case.

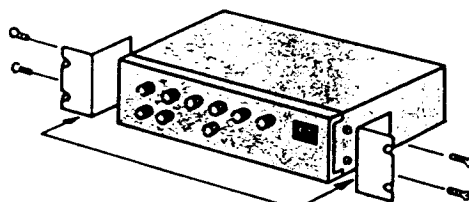

Fix the brackets with attached 4 screws. The length of the screws should not exceed 12mm (1/2 inches).

A-903A (MB-921)

A-906A) (MB-931)
A-912A)

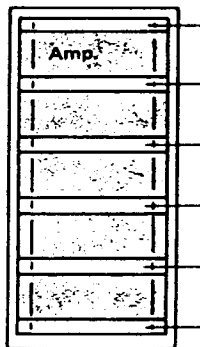

PF-911 (OPTION)

If two or more amplifiers are mounted in an equipment rack, space should be provided between the units for ventilation. The PF-911 Perforated Panel is recommended for this purpose.

Servicing

●Unpacking

Upon receipt of the amplifier shipment, please inspect for any damage incurred in transit. If damage is found, please notify your local TOA representative and the transportation company immediately.

State date, nature of damage, whether any damage was noticed on the shipping container, prior to unpacking. Please give waybill number of shipping order.

●Failure

Should amplifier fail, contact your nearest TOA authorized contractor or service center.

Specifications

	A-903A	A-906A	A-912A
Type	6-channel mixer power amplifier		
Output Power	30 watts RMS	60 watts RMS	120 watts RMS
Power Band Width	(D) 20 – 20,000 Hz, 0.5% THD (T) 50 – 20,000 Hz, 0.5% THD		
Frequency Response	(D) 20 – 20,000 Hz, ±1 dB (T) 20 – 15,000 Hz, ±1 dB (T) 20 – 20,000 Hz, +1 dB -3 dB		
Total Harmonic Distortion	0.02% at 1 kHz, rated output		
Inputs	Six Input Ports: Each port accepts any input module except T-01. Use T-01 only in port #5 or #6. One Bridging Input/Output		
Input Sensitivity/Impedance	Input Ports #1 to #6 : 100 mV/10k ohms Bridging Input/Output: 100 mV/3.3k ohms		
Promo OUT/Power Amp IN	1,000 mV into 600 ohms/1,000 mV, 10k ohms		
Outputs (D) – Direct (T) – Transformer	Main(T): 4 ohms, 25 & 70 volts balanced Main(D): 8 ohms, unbalanced Aux : 10k ohms, 1,000 mV	Main (T) : 8 ohms, 25 & 70 volts, balanced Main (D) : 4 ohms, unbalanced Aux : 10k ohms, 1,000 mV	
Output Regulation (1 kHz)	(D) Less than 0.5 dB, no load to full load (T) Less than 1.0 dB, no load to full load		
Signal to Noise Ratio (Band Pass 20 – 20,000 Hz) Tone Controls Centered	Master volume min. : 90 dB Master volume max. : 77 dB Power amplifier only: 105 dB		
Tone Controls	Bass: ±10 dB at 100 Hz: Treble: ±10 dB at 10 kHz		
Controls	6 Input gain controls 1 Bass tone control	1 Master gain control 1 Treble tone control	

TOA NEW 900 SERIES

Plug-in Modules and Accessories

(OPTION)



The TOA PLUG-IN MODULES are suitable for TOA 900 SERIES MIXER POWER AMPLIFIERS A-901A, A-903A, A-906A, and A-912A MIXER PREAMPLIFIER M-900A, and POWER AMPLIFIERS P-906A, P-912A and P-924. Owing to wide selection of MODULES, the desired applications will be obtained. The various types of connectors can also meet the needs of equipment to be connected. MICROPHONE PREAMPLIFIER H-01 series, H-21 and H-31 incorporates controls for high-cut, low-cut and gain, H-02 series, H-22, H-32 and H-03 series controls for low-cut and gain. A gain control is built in MAG. PHONO PREAMPLIFIERS E-01 and E-11 series, AUXILIARY PREAMPLIFIERS X-01 and X-11 series and X-21, PAGING INPUT I-01 and LINE OUTPUT T-01 series. T-01 series is an output module with transformer, serving as a line output for recording, etc.











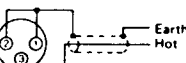

PAGING INPUT I-01 is specially designed to associate with TOA INTERCOM SYSTEMS. It accepts paging signals from the intercom station.

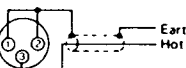
A group of special signal generating modules is also available for catching-attention before announcement and testing within the total system. ALL PLUG-IN MODULES have handles on their front for easy insertion and removal.

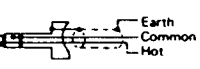
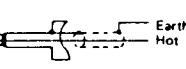
Features:

1. Wide dynamic range
2. Low noise and distortion
3. Wide frequency response
4. Built-in remote volume control circuit (available for models having 20's in its model number such as H-21)
5. Built-in muting circuit to mute incoming signal when MUTE TERMINAL is grounded. (available for modules having 10's in its model number such as X-11)
6. Built-in muting circuit to deliver output signal when MUTE TERMINAL is grounded. (available for modules having 30's in its model number such as H-31)
7. Built-in signal activated muting function (L-41)
8. Presettable gain control (except for B-01, B-11, L-01 and L-11)
9. Microphone modules furnished with tone controls (H-01, H-02, H-21, H-22, H-31, H-32 and H-03)

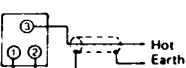
(INPUT CONNECTIONS T & I OUTPUT CONNECTION)

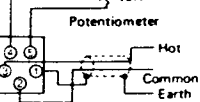
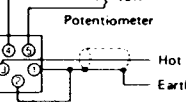
MODEL Connection	PLUG-CONNECTIONS	
	Balanced Connection	Unbalanced Connection
 CANNON XLR-3-13 (Female) type	 CANNON XLR-3-12 (Male) type	 CANNON XLR-3-12 (Male) type
 CANNON XLR-3-14 (Male) type	 CANNON XLR-3-11 (Female) type	 CANNON XLR-3-11 (Female) type
 Phone Plug (Double Pole)	 Phone Plug (Double Pole)	 Phone Plug (Single Pole)
 RCA Phono Jack (20)		 RCA Phono Jack
 3P Screw Terminal (20)	 Hot Common Earth	 Hot Earth
 5P Screw Terminal (20)	 10K Potentiometer Hot Common Earth	 10K Potentiometer Hot Earth

Plug-in Modules

Applications		Module Types	Specifications					
			Source Impedance	Input Sensitivity for Rated Output (100mV)	Gain	Max. Before Clip into 10k-ohm load at less than 0.5% THD (1kHz) [Output Voltage: S-01, S-02, S-03]	Frequency Response ± 1 dB	Noise Level (equivalent input noise or S/N)
Microphone Preamp	Low Z MIC with Low & High filters	H-01 series	Balanced 200 ohms	nominal 1.0 mV adjustable 0.25~25 mV	nominal 40 dB adjustable 52~32 dB	6.3 V (+16 dBv)	25~20,000 Hz	-126 dBm 200 ohms terminated
	Low Z MIC with Low & High filters and remote volume control facilities	H-21						
	Low Z MIC with Low & High filters and MUTE	H-31						
	Low Z MIC with Low-cut filter	H-02 series						
	Low Z MIC with Low-cut filter and remote volume control facilities	H-22						
	Low Z MIC with Low-cut filter and MUTE	H-32						
Mag. Phono Preamp	—	E-01 series	Unbalanced 50k ohms	nominal 3.2 mV adjustable 2.0~5.0 mV	nominal 34 dB adjustable 34~26 dB	6.3 V (+16 dBv)	RIAA Equalized	S/N 70 dB
	with MUTE	E-11 series						
Auxiliary Preamp	—	X-01 series	Unbalanced 220k ohms	nominal 100 mV adjustable 100~3,200 mV	nominal 0 dB adjustable 0~-30 dB	6.3 V (+16 dBv)	20~20,000 Hz	S/N 90 dB
	with MUTE	X-11 series						
	with remote volume control facilities	X-21						
Bridging Transformer	—	B-01 series	Balanced 10k ohms	125 mV	-1 dB	—	20~20,000 Hz	—
	with MUTE	B-11 series						
Line Matching Transformer	—	L-01 series	Balanced 600 ohms	125 mV 125mV [Min. 15 mV to activate] mute function	-2 dB	—	20~20,000 Hz	—
	with MUTE	L-11						
	with Signal Activating Mute	L-41						
Paging Input		I-01	Balanced 600 ohms	nominal 3.2 V adjustable 3.2~10 V	nominal -30 dB adjustable -30~-40 dB	—	500~20,000 Hz Low-cut 250 Hz	—
Line Output		T-01 series	[Output Balanced 600 ohms]	—	nominal 20 dB (1.0 V output) adjustable 20~4 dB (1.0 V~158 mV)	6.3 V (+16 dBv) 4.7 V (+13.4 dBv) into 600-ohm load	30~20,000 Hz	S/N 80 dB
Tone Signal Generator	1kHz Sine Wave	S-01	—	—	—	0.5 V (-6dBv) 0.5% THD	—	S/N 80 dB
	Buzzer/Yelp	S-02	—	—	—	1V peak to peak	—	S/N 80 dB
	One Tone / Continuous Chime	S-03	—	—	—	1V peak to peak	—	S/N 80 dB

• FRONT PANEL CONTROLS AND FEATURES

Modules with built-in controls are provided in the following five types.

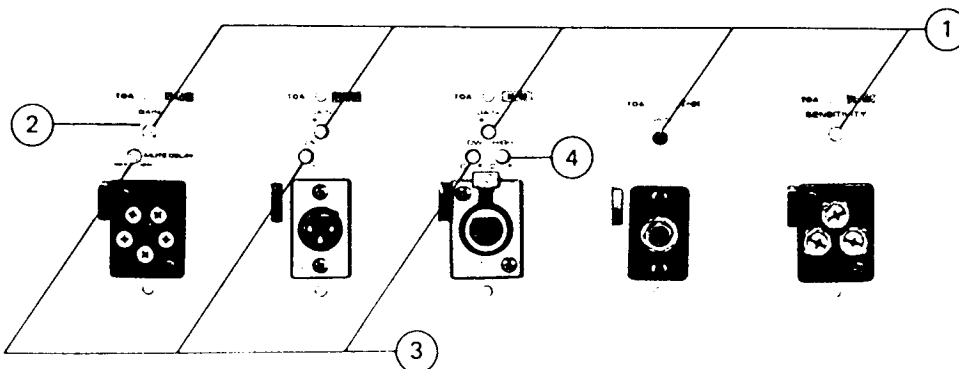

① GAIN CONTROL

This adjusts gain. Turn clockwise (CW) to increase and counterclockwise (CCW) to reduce gain.







Set the gain as low as possible, thereby noise can be reduced, and the maximum permissible input level is raised.

SENSITIVITY CONTROL (L-41S)

This adjusts sensitivity for muting other modules having MUTE function. Turn CW to raise and CCW to lower sensitivity. Setting position should depend on the equipment connected with L-41S.

② NOMINAL POSITION MARK

⊙ The left figure shows nominal setting of controls.

Specifications						Connector					
Frequency Response ± 1 dB	Noise Level equivalent input noise or S/N*	Signal Muting Level	Remote volume control range (Use 10k ohms potentiometer)	Controls (pre-settable)	Weight (max.)	 XLR-3-13 (F) Type	 XLR-3-14 (M) Type	 Phone Jack (P)	 RCA Phono Jack (R)	 3P Screw Terminal(S)	 5P Screw Terminal(S)
25~20,000 Hz	-126 dBm 200 ohms terminated	60 dB	—	1-Low cut 1-High cut 1-Gain	105 gr (3.71 oz)	H-01F	H-01M	H-01P	—	H-01S	—
			0~ -60 dB		100 gr (3.53 oz)	—	—	—	—	—	H-21S
			—		105 gr (3.70 oz)	—	—	—	—	H-31S	—
		—	0~ -60 dB	1-Low cut 1-Gain	100 gr (3.53 oz)	H-02F	H-02M	H-02P	—	H-02S	—
					95 gr (3.35 oz)	—	—	—	—	—	H-22S
					105 gr (3.70 oz)	—	—	—	—	H-32S	—
20~20,000 Hz	S/N 70dB	—	—	1-Low cut 1-Gain	60 gr (2.12 oz)	—	H-03P	H-03R	—	—	
RIAA Equalized	S/N 70 dB	—	—	1-Gain	50 gr (1.76 oz)	—	—	—	E-01R	E-01S	—
		60 dB			55 gr (1.94 oz)	—	—	—	E-11R	E-11S	—
20~20,000 Hz	S/N 90 dB	—	—	1-Gain	70 gr (2.47 oz)	X-01F	—	X-01P	X-01R	X-01S	—
		60 dB			75 gr (2.65 oz)	X-11F	—	X-11P	X-11R	X-11S	—
		—			65 gr (2.29 oz)	—	—	—	—	—	X-21S
20~20,000 Hz	—	—	—	—	90 gr (3.17 oz)	B-01F	—	B-01P	—	B-01S	—
		60 dB			95 gr (3.35 oz)	B-11F	—	B-11P	—	B-11S	—
20~20,000 Hz	—	—	—	—	90 gr (3.17 oz)	L-01F	—	L-01P	—	L-01S	—
		60 dB			95 gr (3.35 oz)	—	—	—	—	L-11S	—
—	—	—	—	1-Sensitivity	95 gr (3.35 oz)	—	—	—	—	L-41S	—
500~20,000 Hz Low-cut 250 Hz	—	—	—	—	1-Mute 1-Gain	100 gr (3.53 oz)	—	—	—	—	I-01S
30~20,000 Hz	S/N 80 dB	—	—	—	1-Gain	100 gr (3.53 oz)	—	T-01M	T-01P	—	T-01S
		60 dB			1-Output	55 gr (1.94 oz)	—	—	—	—	S-01S
—	S/N 80 dB	—	—	—	1-Output	60 gr (2.12 oz)	—	—	—	S-01S	—
—	S/N 80 dB	—	—	—	1-Output	70 gr (2.47 oz)	—	—	—	S-03S	—

* 0 dBv = 1 volt \approx +2 dBm.

* Specifications are subject to change without notice.

• SPECIFICATIONS IN COMMON

Load impedance : 10k-ohms
 Mounting : Card-edge connector
 Dimensions in mm (inches) : 78(3.07)x35(1.38)x88(3.48)
 (H) x (W) x (D)

CAUTION:

* Modules model E-11, X-11, B-11, L-11, L-41, H-31, H-32, and T-01 should be used exclusively with models A-903A, A-906A, A-912A and M-900A.

adjusts gain. Turn clockwise (CW) to increase and counterclockwise (CCW) to reduce gain.

adjusts the gain as low as possible, thereby, the gain can be reduced, and the maximum possible input level is raised.

adjusts sensitivity for muting other modules having MUTE function. Turn CW to raise and CCW to lower sensitivity.

mounting position should depend on the element connected with L-41S.

The left figure shows nominal setting of controls.

③ LOW-CUT FILTER CONTROL
 330Hz, 6dB/oct (max. attenuation)

MUTE DELAY CONTROL (I-01S)

④ HIGH-CUT FILTER CONTROL
 4.2kHz, 6dB/oct (max. attenuation)



This provides flat characteristics at full CW position and attenuation in low frequency by turning CCW. Adjust it to obtain proper tone quality. With low-cut, tone becomes clear.

This adjusts MUTE delay time which is the duration from signal input to its output. Turn CW to shorten and CCW to lengthen the time.

This provides flat characteristics at full CW position and attenuation in high frequency by turning CCW. Adjust it to obtain proper tone quality. With high-cut, tone becomes soft.

TOA NEW 900 SERIES

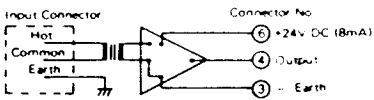
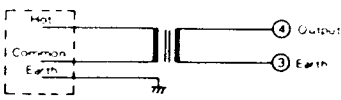
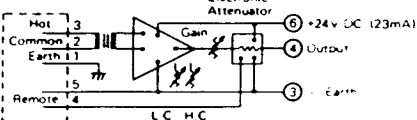
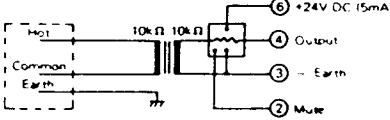
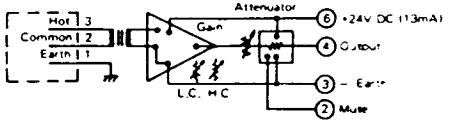
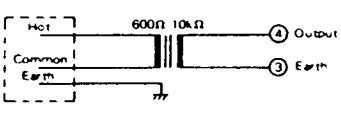
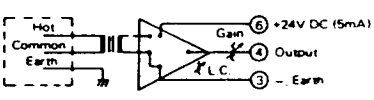
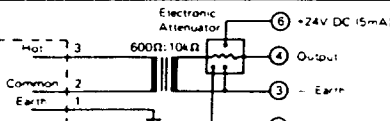
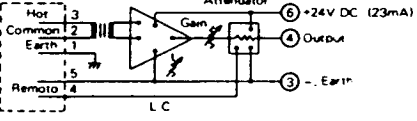
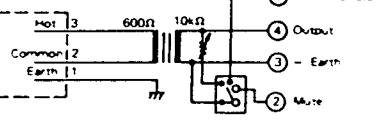
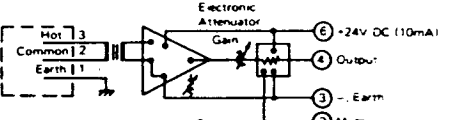
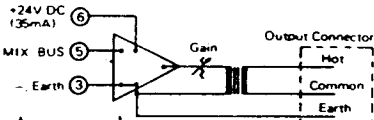
Block Diagrams (Plug-in Modules)

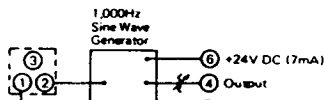
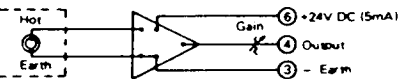
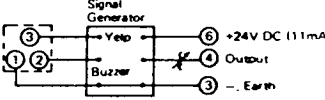
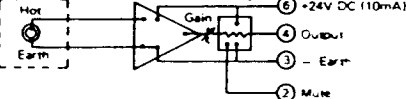
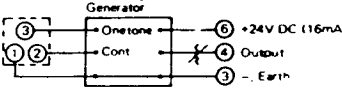
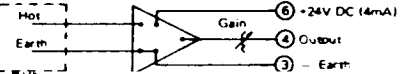
<p>H-01 Series</p> 	<p>B-01 Series</p> 
<p>H-21S</p> 	<p>B-11 Series</p> 
<p>H-31S</p> 	<p>L-01 Series</p> 
<p>H-02 Series</p> 	<p>L-11S</p> 
<p>H-22S</p> 	<p>L-41S</p> 
<p>H-32S</p> 	<p>T-01 Series</p> 
<p>H-03 Series</p> 	<p>S-01S</p> 
<p>E-01 Series</p> 	<p>S-02S</p> 
<p>E-11 Series</p> 	<p>S-03S</p> 
<p>X-01 Series</p> 	<p>I-01S</p>

Operation and Connections (Plug-in Modules)

- E-11, X-11, L-11, B-11 Series, H-31 and H-32 (with mute)

Connections

(M-900A, A-903A, A-906A, A-912A)

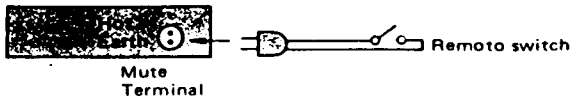

Operation

When the switch is closed,:

- the signal fed to E-11, X-11, L-11 and B-11 are attenuated by approx. 60dB. Accordingly a microphone can have a priority at a time of announcement.
- the signal fed to H-31 and H-32 are delivered to the amplifier. (While the switch is opened, the signals are attenuated.)

- L-41 (with signal activated muting facilities)

When this module accepts the input signal, the mute terminal is grounded automatically without connection of the remote switch to the MUTE TERMINAL. It causes the other modules with mute function, like X-11, to be muted. Accordingly the signal fed to the L-41 can have a priority.

- H-21, H-22 and X-21 (Remote volume control facilities)

Connections

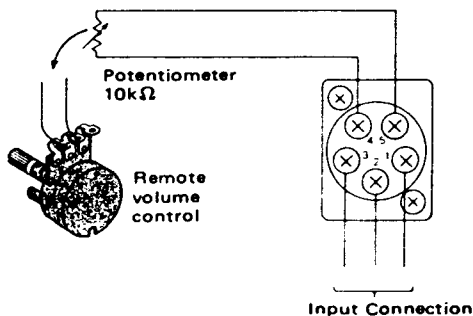

Operation

Preset the gain control of module and the input volume control of the corresponding input so that an appropriate sound level may be obtained through the remote volume control.

CAUTION

Use the potentiometer of 10K ohms.
Make wiring lest the interference from external noise should occur.

- T-01 SERIES (BALANCED 600-ohm LINE OUTPUT MODULES)
- This series of modules, of rated output level 1 volt, is used for transmitting mixing signals of amplifiers to external equipment and as a REC out.

It is provided with a presettable gain control.

T-01 Series should be used exclusively for TOA 900 series, A-903A, A-906A, A-912A and M-900A. Use it only in Input Port #5 or #6 of the above models. It will not operate when connected into other PORTS.

Approx. 5 seconds after power has been supplied to these modules, the output signal is transmitted.

- S-01 (1,000Hz SINE WAVE)

Connections

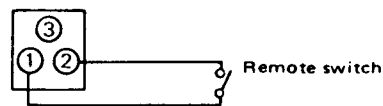

It is operated by closing the remote switch.

- S-02 (YELP AND BUZZER)

Connections

Yelp signal

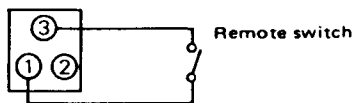

Buzzer signal

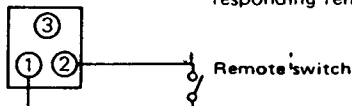

Each signal is generated by closing corresponding remote switch.

- S-03 (ONE-TONE CHIME AND CONTINUOUS ONE-TONE CHIME)

CONNECTIONS

One-tone chime

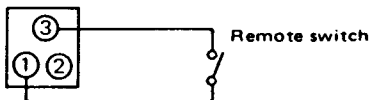

By closing the remote switch, chime sounds once.

Continuous one-tone chime

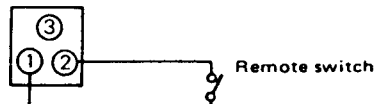

By closing the remote switch, one-tone chime sounds continuously during the closure of the switch.

TOA NEW 900 SERIES

• I-01S (BALANCED PAGING INPUT MODULE)

This module is used for connecting TOA intercom Systems (EXES) for paging. By connecting this module to the exchange in place of an intercom station, paging is possible. It is provided with a pre-settable gain control. The I-01S is applicable to the TOA EXES-1000, EXES-5000 and EX-16 Intercom Systems.

CONNECTIONS

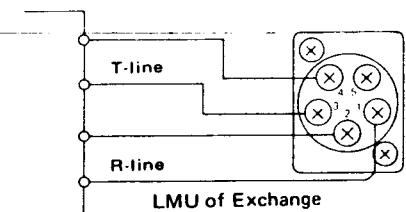

LMU (Line Modem Unit)

This unit is composed of a modulator to receive signals from stations, a demodulator to send signals to the station and a scanning circuit.

Summary Specifications of R and T Lines

R-line: Approx. 9mA DC plus audio signals of +30dBm max.

T-line: Approx. 9mA DC

HOW TO USE:

Paging is possible from other station by dialing the station number assigned to this module. To prevent a calling tone from being sounded through the paging speaker, the module is designed to override paging output during a period of time that the calling tone signal is transmitted. The length of time to mute the paging output is adjustable between zero and three seconds. During paging, background music (the input signal fed to E-11, X-11, L-11 or B-11 module) is muted.

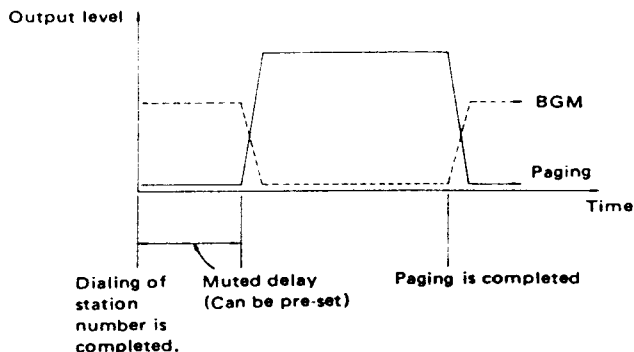

Optional Accessories

Rack-mounting Brackets (Silver)



MB-931A



MB-921A

A-906A
A-912A
P-906A
P-912A
P-924

M-900A
A-903A

Perforated Panel (Silver)



PF-911

Volume Control Cover

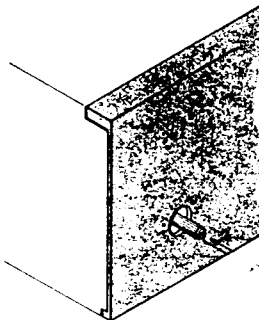

YA-910 (BLACK)

