Planning and Installation KI-1681D

CTL1 Telecenter[®] 1100 Telephone Interface Module



Rauland-Borg Corporation

Issued: 07/02/98

Page 1 of 12

Copyright 1994 by Rauland-Borg Corporation, all rights reserved.

This document contains user's information on technology that is proprietary to Rauland-Borg Corporation. Permitted transmittal, receipt, or possession of this document does not express license or imply any rights to use, sell, design or manufacture this information. No reproduction, publication, or disclosure of this information, in whole or in part, shall be made without prior written authorization from an officer of Rauland-Borg Corporation.

©Rauland-Borg Corporation

Rauland-Borg Corporation
3450 West Oakton Street
Skokie, Illinois 60076-2958
(847) 679-0900
www.rauland.com

Table of Contents

GENERAL INFORMATION	4
<i>“D” and “S” Series Systems</i>	<i>4</i>
DOCUMENT REVISION HISTORY	4
DRAWINGS, DIAGRAMS, AND OTHER GRAPHICS	4
SOFTWARE AND CODE REVISION HISTORY	5
PACKING LIST	5
SYSTEM EQUIPMENT.....	6
<i>Standard System Equipment</i>	<i>6</i>
<i>Optional Central Equipment.....</i>	<i>7</i>
<i>Room Stations.....</i>	<i>8</i>
CABLING.....	9
INSTALLATION.....	10
LOCATION.....	10
PROGRAM CHIPS	10
PROGRAMMING	11
<i>CTL1 and Single-Button-Answering Enable.....</i>	<i>11</i>
<i>No Remote Phone or Monitoring or Auto-Answering</i>	<i>11</i>
CTL1 CHIME-TONE AND PREAMP LEVELS.....	11
APPENDIX A.....	12
ILLUSTRATIONS AND DIAGRAMS	12

1

General Information

This module enables an individual DTMF telephone or an electronic key system to control a Telecenter® 1100 communications system. The telephone user can dial individual rooms, answer call-ins by pressing a single push button, and use the keypad to select paging zones and distribute audio programs. Room stations can have non-dialing telephones as well as speakers.

“D” and “S” Series Systems

In both “Dial-up” and “Switch-bank” Systems, all the above functions can be controlled by a DTMF telephone. In “Switch-bank” Systems, room-selector panels offer a second way of distributing audio programming and provide two audio program sources.



Important:

Refer to the attached wiring diagrams for the descriptions given in this section.

Document Revision History



This is the fifth release of this manual. Earlier editions were issued on 11/91, 2/93, 6/94, and 10/95.

Drawings, Diagrams, and Other Graphics



This document includes the following drawings, diagrams, and/or supplemental graphics:

- ✓ 2524 Program Chips and Header for CTL1 (IL0360)

- ✓ CTL1 Potentiometers and Header for 2524 (IL0360)
- ✓ CTL1 Mounting Telephone PCBs for Telecenter 1100 Systems (IL0408)
- ✓ CCOM D-Series Wiring Diagram (KM1033)
- ✓ CCOM System Wiring Diagram with 2-Wire Adapter—TW25 (KM1042)
- ✓ CCOM System Wiring Diagram with PLA1 (KM1045)
- ✓ CCOM S-Series Wiring Diagram (KM-1032)

Software and Code Revision History



This 5.6 version offers “fixes” for the following bugs:

Known Bug	Fix Status
If an external all page was in progress and a call-in was placed, the system locked up.	The system no longer locks up.
If a zone page was in progress and an external page was performed, on hangup the zone page was cancelled.	The zone is restarted once the all page is completed.
The seven segment LED display did not display BUDY when an external page was performed.	The system flashes BUSY when an external page is performed.

Packing List



The CTL1 module is meant to extend the functions of a Telecenter 1100 communications system. The enhanced functions also require some additional equipment:

Quantity	Part	Part Number
2	EPROMs labeled “U1” and “U2”—these replace the standard software chips in the 2524 Master Clock and Intercom Controller, to add the CTL1 telephone functions.	U1, U2
4	Stand-offs (feet) with adhesive tape for module surface mounting	n/a
1	34-pin flat cable and two connectors, for linking the module with the 2524. In early units, these came unassembled	n/a

System Equipment

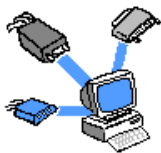

The following sections present information on both Standard and Optional system equipment:



Important:

Be sure to set the DIP switch in each TC4110 or TC4130 panel—see the 2524 installation manual, KI-1628.

Standard System Equipment

2524 Master Clock and Intercom Controller: This provides the basic control functions for intercom as well as full master-clock functions (updating secondary clocks, ringing bells, providing music during class changes, and controlling lights and equipment via relays).



Important:

The 34-pin ejector header for the flat cable from the CTL1 is not installed on early 2524 units. This SM0316-34 header can be ordered directly from Rauland.

Speaker-Control Panels: Rauland switch and relay panels can each handle 25 room stations.

In “D” Series systems, TC4130 rack-mount relay panels switch room speakers individually for intercom functions, and in groups for sending pages and distributing audio programs.

In “S” Series systems, which can control program distribution by manual switches as well as by dialing, use a combination of SW25 switch panels and TC4110 relay panels. The SW25 has a three-position toggle switch for each room, which allows the manual selection of two different audio sources.

Intercom Amplifier: The Rauland TC4160 Intercom Amplifier enables a telephone to talk with a room speaker. The Intercom Amplifier is normally in the “listen” mode, so that the administrative telephone can hear the room. However, when the administrative telephone’s user begins speaking into the mouthpiece, the Intercom Amplifier automatically switches to the “talk” mode. Only one module is needed in a system.

Administrative Telephone: The CTL1 will accept one line for DTMF telephones. This line can serve a single DTMF (dual-tone, multiple-frequency) phone, or it can accept a line from the trunk port of an electronic key system.

Display: To give the user essential feedback (the number of a room calling in, zones selected, etc.), each control telephone should have a display. A TC4222 Vacuum Fluorescent Display can be mounted on a wall, where its large, bright display can serve more than one telephone (see KI-1683). Alternatively, TC4221 Digital Displays can be attached to individual telephones (see KI-1698). Consult these manuals for the limits on the number of displays that can be used, the DIP switch settings, and on their distance from the central system.

Power Amplifiers: Sending paging announcements requires a power amplifier capable of driving all room speakers at once. An amplifier wired to the CTL1’s “Amp In” output will handle both program material from one audio source and paging announcements. Adding a second program source in an “S” Series system would require a second power amplifier. Good amplifier choices would be Rauland’s DAX60, DAX120, and FAX250 models.

Optional Central Equipment

The following equipment provides enhancements beyond the basic intercom functions:

Audio Program Sources: Almost any program source that can drive a standard “auxiliary” input can be used. A versatile choice is the Rauland MCX300 AM/FM Tuner and Tape Cassette Player. This unit comes with its own power supply and is designed for rack-mounting. Each program channel requires its own power amplifier. As explained in the preceding subsection, the amplifier used for paging doubles as the “A-Channel” program amplifier.

MTG100 Multi-Tone Generator: The CTL1’s built-in chime-tone generator provides a class-change signal. The MTG100 will supply this tone and three additional tones (e.g., European siren) that can be sounded at will by dialing the appropriate code.

PLA1 Priority Line Adapter: Adds another phone line to the CTL1 system which has priority over the normal line. Off-hook sensing causes the priority line (instead of the normal line) to switch to the CTL1. When the priority line senses an off-hook, a busy signal sounds on the normal line. After the priority call is complete,

the system disconnects the room speaker and sends a dial tone through the normal line.

TW25 Two-Wire Adapter: Allows room call-in using a shielded two-wire cable. Special restrictions apply for use with the CRT3 classroom phones. See the attached drawing, KM1042, for wiring information.

Room Stations

A speaker enables a room to carry on two-way conversations with the administrative telephone. Even if staff telephones are used, speakers are needed to signal calls. Any of Rauland's standard room speakers that have transformers and center-tap connections can be used. Representative examples are the US0188 eight-inch speaker and the RS505 speaker module.

A normal call-in can be sent by either pressing a momentary-contact push-button or lifting the receiver on a room Staff telephone. The system will also accept emergency call-ins. However, privacy switches cannot be used on the standard TC1100 system until a modification is made. The CTL1 board has a jumper located near Xtall for either phone or privacy switch. The jumper is a sleeve that is placed over the two pins on phone for standard units from the factory. If the Staff telephones are not used then the jumper can be moved to the other position for use with privacy call switches (such as P2307). This privacy function applies only to systems without TW25 boards using two wire call-in.



Important:

Adding this privacy function to earlier systems shipped before 1997 required an internal modification to the PC board. For further details, please contact the Rauland-Borg Sales Engineering department.

A dial-less phone, like Rauland's CRT3, makes an ideal staff phone. It is recommended that you install a 1342 Limiter Module across the "T" and "R" terminals of each staff telephone's modular jack. This will protect the user's hearing: incorrect wiring or a fault (a short or an open) could create an unbalanced audio line, which, in turn, could cause an excessively loud sound in a telephone receiver during paging or tone signaling.

Aside from the privacy switch, which cannot be used in standard TC1100 systems, you can follow the room-station wiring diagram (KM1014) in the 2524 installation manual (KI-1628).

Cabling

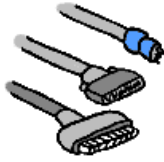

Flat Cables: As stated in the parts list, the CTL1 comes with the 34-pin cable and connectors. Note that this cable must be no longer than 1.5 feet.

The relay panels come with 26-pin connectors, but the customer must supply the flat cable. All these panels should be daisy-chained on this cable.

Speaker and Telephone Lines: Use a twisted pair and a single conductor in an overall shield. The room-station wiring diagram (KM1014) in the 2524 installation manual lists the maximum lengths for the common wire gauges.

Display Cables: Use a shielded pair, and observe the distance restrictions listed in the pertinent display manual.

2

Installation

Most of the information needed is on the attached wiring diagrams. Here is additional information:

Location

In factory-assembled Telecenter 1100 systems, the CTL1 board mounts onto the A3774 metal chassis. This chassis also holds other Telephone PCB's (e.g., TCS4530, MTG100, TC4160, VC6381, PLA1, and TCS4531) for the Telecenter 1100 and other systems. Each board strategically mounts into the chassis using the supplied plastic stand-offs. IL0408 shows three examples of the chassis depicting the proper placement of each board.

The CTL1 board has to be close enough to the 2524 for the 18-inch flat cable to link the two units. This means placing the chassis on top of the 2524 or next to it, on the inner side of the rack. Place the module away from sources of magnetic radiation, such as large power transformers.

An alternate method, for field installations, is to mount the board with the four plastic stand-offs. Snap them into the corner holes of the board, peel the plastic sheets from the bottom of the feet, then press the board in place for a moment, to allow the adhesive to take hold. Carefully align the module before touching the feet to a surface, because they hold firmly once they have contacted a surface.

Mount the optional PLA1 Circuit Board near the CTL1 board using four plastic stand-offs. Refer to the wiring diagram KM1045 for more information.

Program Chips

Replace the two program EPROMs on the 2524 PC board with the "U1" and "U2" chips supplied with the CTL1 (see the attached IL0360).

Programming

What follows is the special programming required by the TC1100 system. For the rest of the intercom programming and all of the clock programming, follow the instructions in the 2524 programming manual (KI-1629).

CTL1 and Single-Button-Answering Enable

Enter Comm Mode 3 in the programming sequence. Select LED 7 to enable the 2524 to use the CTL1 module. Select LED 8 to activate the single-button-answering function.

No Remote Phone or Monitoring or Auto-Answering

Since a Telecenter 1100 system cannot have a remote telephone, use the monitoring function, or auto-answer priority call-ins, the system will ignore any programming for them.

CTL1 Chime-Tone and Preamp Levels

The two potentiometers on the CTL1 can be adjusted by hand or with a narrow-bladed screwdriver. Turning them clockwise increases the output.

- ✓ RP1, to the right of the terminal strip (as viewed from the rear), adjusts the output of the built-in preamp, which is used for paging functions.
- ✓ RP2, to the left of the terminal strip (as viewed from the rear), adjusts the output of the built-in chime-tone generator.

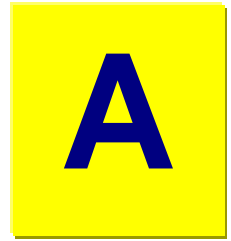

Appendix A

Illustrations and Diagrams



Appendix A contains the following illustration and diagrams:

- ✓ 2524 Program Chips and Header for CTL1
- ✓ CTL1 Potentiometers and Header for 2524
- ✓ CTL1 Mounting Telephone PCBs for Telecenter 1100 Systems
- ✓ CCOM D-Series Wiring Diagram
- ✓ CCOM System Wiring Diagram with 2-Wire Adapter (TW25)
- ✓ CCOM System Wiring Diagram with PLA1
- ✓ CCOM S-Series Wiring Diagram

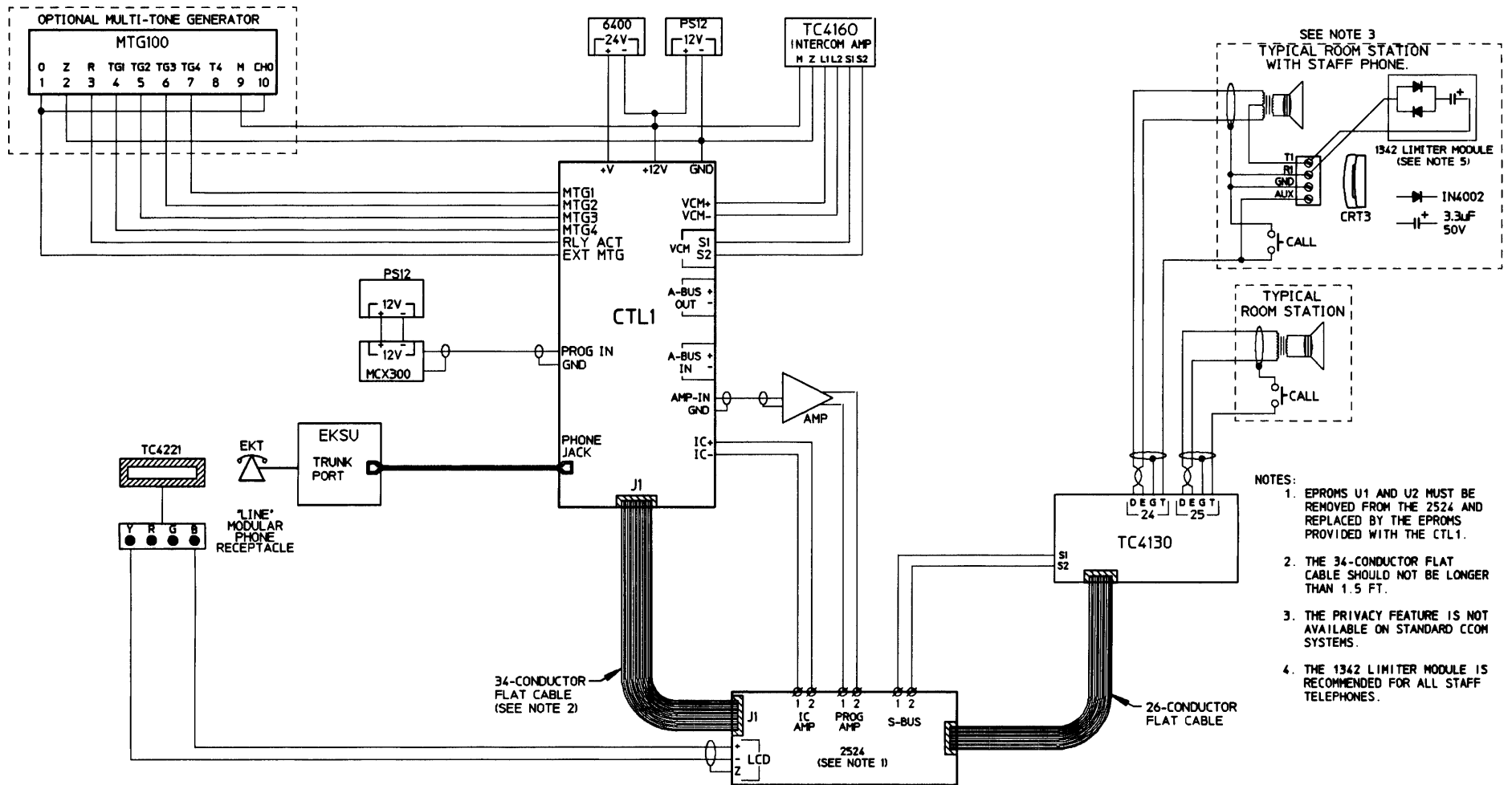

- NOTES:
1. EPROMS U1 AND U2 MUST BE REMOVED FROM THE 2524 AND REPLACED BY THE EPROMS PROVIDED WITH THE CTL1.
 2. THE 34-CONDUCTOR FLAT CABLE SHOULD NOT BE LONGER THAN 1.5 FT.
 3. THE PRIVACY FEATURE IS NOT AVAILABLE ON STANDARD CCOM SYSTEMS.
 4. THE 1342 LIMITER MODULE IS RECOMMENDED FOR ALL STAFF TELEPHONES.

CCOM D-SERIES WIRING DIAGRAM

CCOM D SERIES
WIRING DIAGRAM
RAULAND-BORG CORP.
SKOKIE, IL, U.S.A.
KM1033 - B

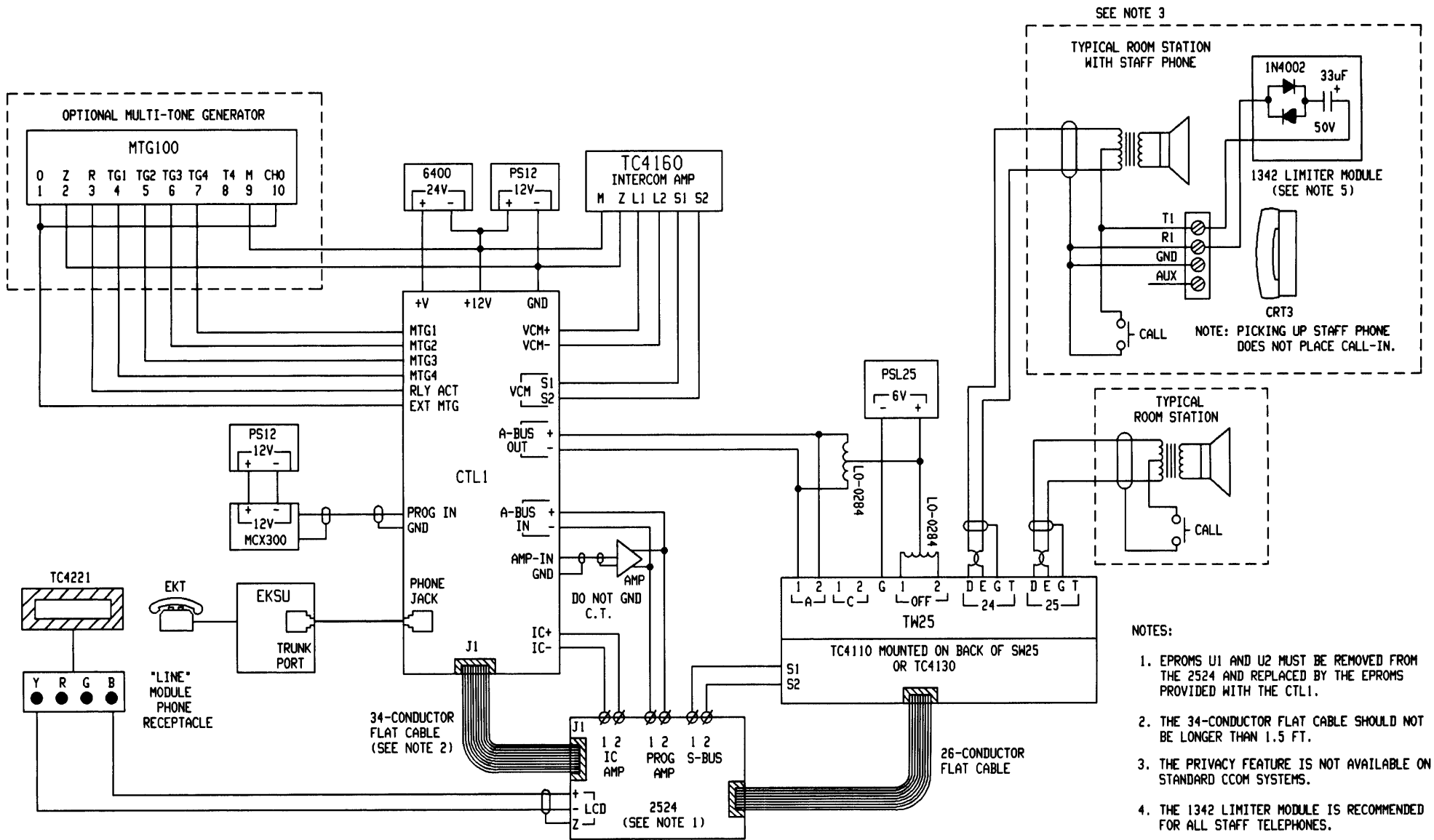

CCOM SYSTEM WIRING DIAGRAM WITH 2-WIRE ADAPTER (TW25)

CCOM SYSTEM
WIRING DIAGRAM
WITH 2 WIRE ADAPTER (TW25)
RAULAND-BORG CORP.
SKOKIE, ILL, USA
KM1042 - B

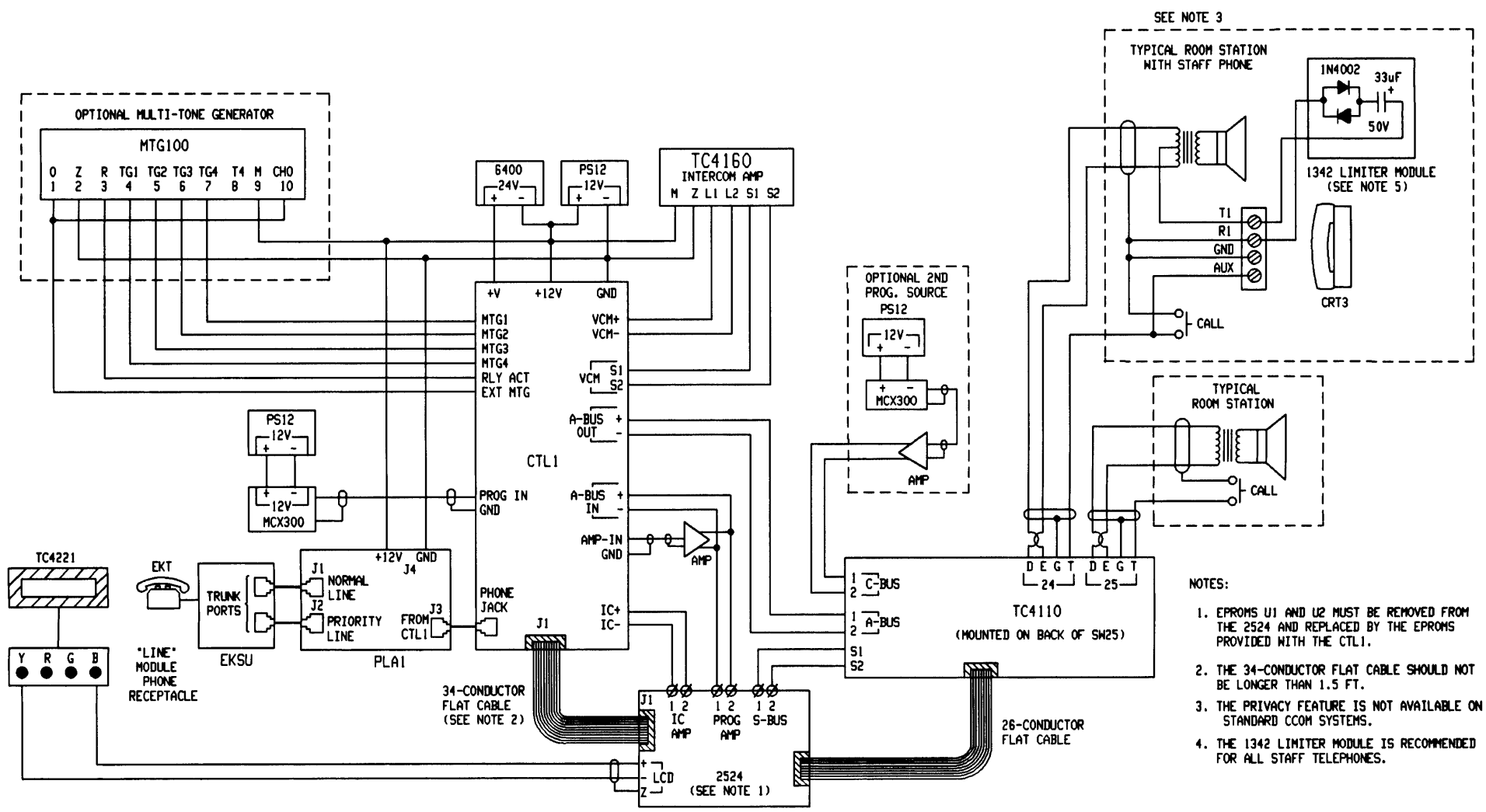

CCOM SERIES WIRING DIAGRAM WITH PLA1

CCOM SERIES
 WITH PLA1 WIRING DIAGRAM
 RAYLAND-BORG CORP.
 SKOKIE, ILL, USA
 KM1045 - B

