



SW25 & SWL25 Room-Selector Panels Installation

Rauland-Borg Corporation • 3450 West Oakton Street, Skokie, Illinois 60076-2951 • (847) 679-0900

General Information

Description

The SW25 and SWL25 panels are used with all Director® Series sound and communications systems. These panels let you selectively connect up to 25 rooms to either the program or the intercom channel. There is also a center OFF position. Color-coded directions identify each channel: green for program, and orange for intercom.

The SW25 offers room selection only (no call-in signal).

The SWL25 also provides a call-in signal. When a call is made from a switch in the classroom, an LED lights next to the corresponding number on the panel and a tone alerts the console operator to the call. The LED lamp remains lit until the operator answers the call, at which time the lamp automatically shuts off.

Installation

Cabling Requirements

Systems using the SW25 (no call-in signal) require one twisted pair in a shield for each speaker station. Systems using the SWL25 (call-in signal) require one additional conductor within the shielded cable for each speaker station. Use #22-AWG solid or stranded conductors with 22-AWG drain wire. If you're using insulation-piercing connectors, the outside diameter of any wire, including its insulation, must not exceed 0.095".

slots in the connector shells for loop-throughs between switchbanks.

Recommended Terminations

Insulation-piercing connectors are the fastest, most reliable way to terminate wire to the switchbank. These connectors must be ordered separately. Order one SK-2522 Connector Kit for each switchbank. The kit contains 25 four-terminal connectors for 22-AWG wire. The attached manual, KI-1564, tells how to install these connectors.

Cable Routing and Strain Relief

Route the cables as shown in the diagram. Secure them with three plastic cable ties through the guide loops in the rear bracket. Leave service loops in the cables used to interconnect the equipment panels and at least a one-inch slack in each cable. This permits reconnection when required.

Alternative Method #1

Modified wire wrapping may be used to terminate 22- or 24-AWG solid conductors. Strip back wire about 1" and use a wire-wrapping tool that provides one complete turn of insulation around the terminal pin. This modified wire wrap provides the required strain relief.

Connect the twisted pair to terminals *D* and *E*, and the drain wire to terminal *G* for each line circuit. On Model SWL25 only, connect the third conductor for call-in to terminal *T* (Trigger).

Alternative Method #2

Crimped connectors may be used where there is a mixture of wire gauges (18-24 AWG) in the system, or where preferred. Multiple-gauge crimped connectors and an adapter shell are required for this termination method. Order one CTA25 Terminal Adapter Kit for each switchbank in the system. The kit contains 25 four-terminal adapter housings and 100 crimp connectors. Hand Tool G2501 (or the older G317A) is required to crimp the connectors onto the wires.

Connector or Bus Wiring

There are three terminals (OFF, A, C) at the ends of the switchbank that will be interconnected in a factory-wired system. These interconnections provide loop-through for common functions, especially between multiple switchbanks. For wiring details, read the instruction manual for the proper program and intercom equipment panel. When you're wiring to these end terminals, you may need to cut

Strip away about 1¼" of the cable sheathing and shield, then strip the individual wires about ¼". Crimp each terminal onto a wire using Molex Model HTR-2445-A

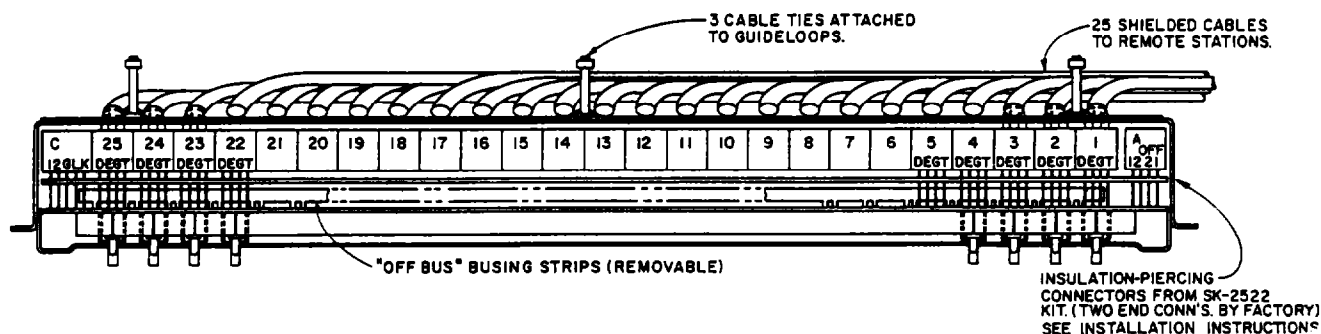

Cable Installation (from KM0520A)

(Molex Part No. 11-01-0026); a reliable connection *cannot* be made using another tool. Insert each crimped terminal into an adapter housing.

Special Applications

It is possible to modify the panels' *OFF* and *C* buses for special applications. For example, you can isolate the *OFF* lines to prevent the distribution of the ALL-CALL function to the isolated remote speaker lines.

To access the buses: Carefully remove the front dress panel by removing its two finish screws and pulling it off. Then remove the eight small Phillips screws on the front of the sub-panel and the two hex-head sheet-metal screws holding it to the rear of the chassis, and pull it off (you will have to spread its sides a bit to clear the PC board). Carefully spread the two main PC boards apart (they are joined at one edge by multiple wires).

The *OFF* bus is a small PC board that is perpendicular to the board with the selector switches. Note that each switch is connected to a trace on either side of this bus board. Cut the traces as needed, and make any connections to the solder pads on the bus board.

The *C* bus conductors can be easily cut with a sharp knife to isolate the *C* lines for multiple-master operation. Use the low-numbered switches (1,2,3, etc.) for master stations. Make a $\frac{1}{32}$ " cut through the top and bottom circuit board conductors where the split is needed. Make the *C* bus connections for low-numbered switches by soldering a pair of wires to the two pads provided at the upper left corner of the circuit board (as viewed from the front). Make the *C* bus connections for the other side of the split to the regular *C* terminal pins. To operate with multiple-channel remote stations, you must split the *C* bus and completely cut both sides of the *OFF* bus.

Pre-1987 SWL25 Units:

If you change a silicon-controlled rectifier (Rauland Part No.ETS008), make sure that the associated R2 is 330 ohms.

Interconnections

There are certain restrictions and specific interconnections to be made, depending upon the associated modules used in the system. For more details, read the instructions provided with that equipment.

DRG NO.	KC1334	A
DATE	5-31-78	
ISSUE	CHANGE	
A	ADDED NOTE ABOUT PAD SCREENING. 4-19-88	

USE XC1, XC2 PADS TO CONNECT TO "AUX C BUS"
WHEN C BUS CONDUCTORS ARE CUT BETWEEN SWITCHES IN MULTI-
MASTER APPLICATIONS (THE PADS ARE NOT SCREENED ON ALL PCBs).

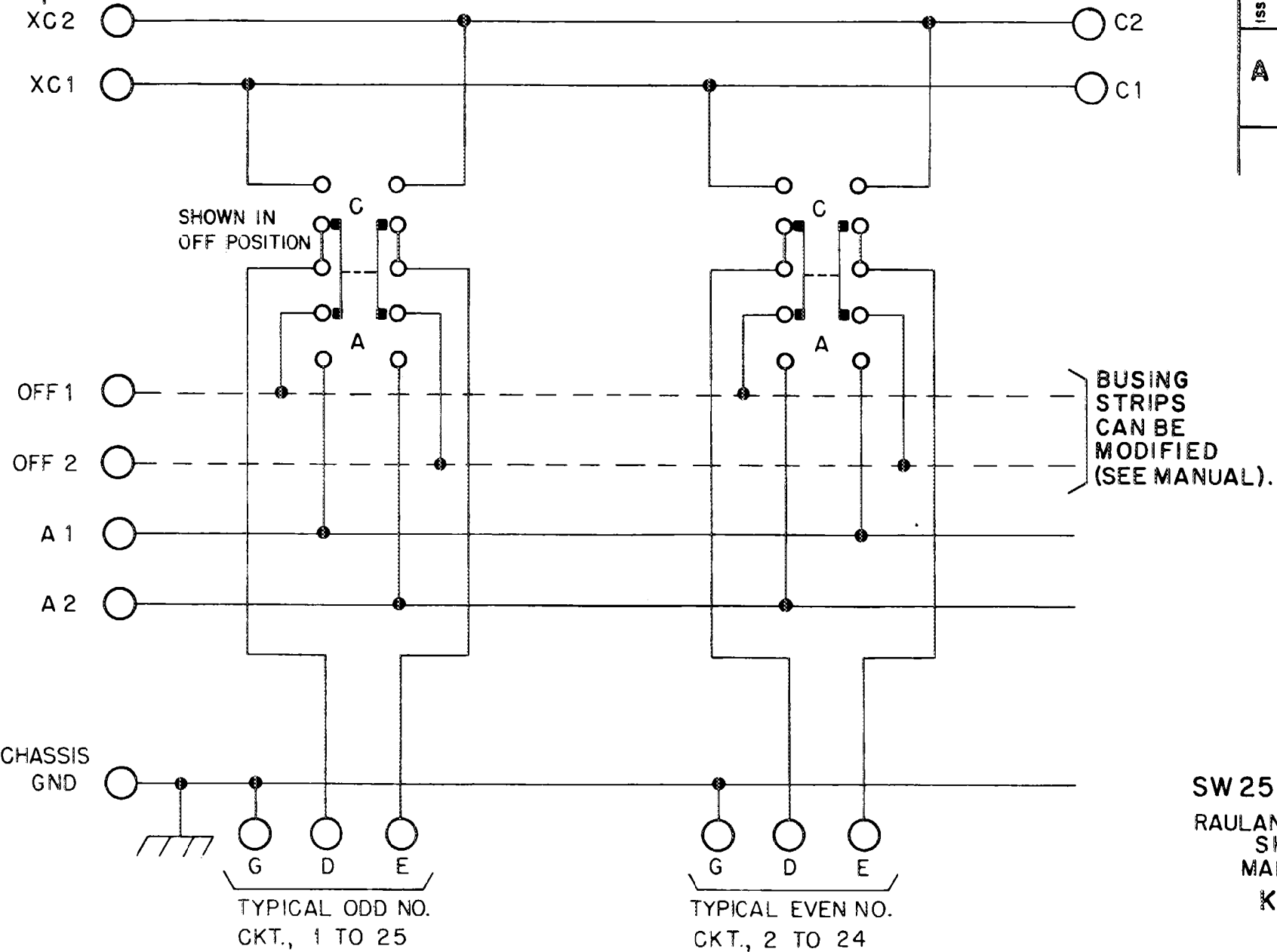

SW 25 SWITCHBANK
RAULAND-BORG CORP.
SKOKIE, ILL.
MADE IN U.S.A.
KC1334 **A**

Dwg. No.		KC1335	B
...	CHANGE		
A	R2 WAS 150.		
	1-26-87		
B	ADDED NOTE ABOUT PAD SCREENING.		
	4-20-88		

USE XC1, XC2 PADS TO CONNECT "AUX C BUS" WHEN C BUS CONDUCTORS ARE CUT BETWEEN SWITCHES IN MULTI-MASTER APPLICATIONS. (PADS NOT SCREENED ON ALL PCB'S)

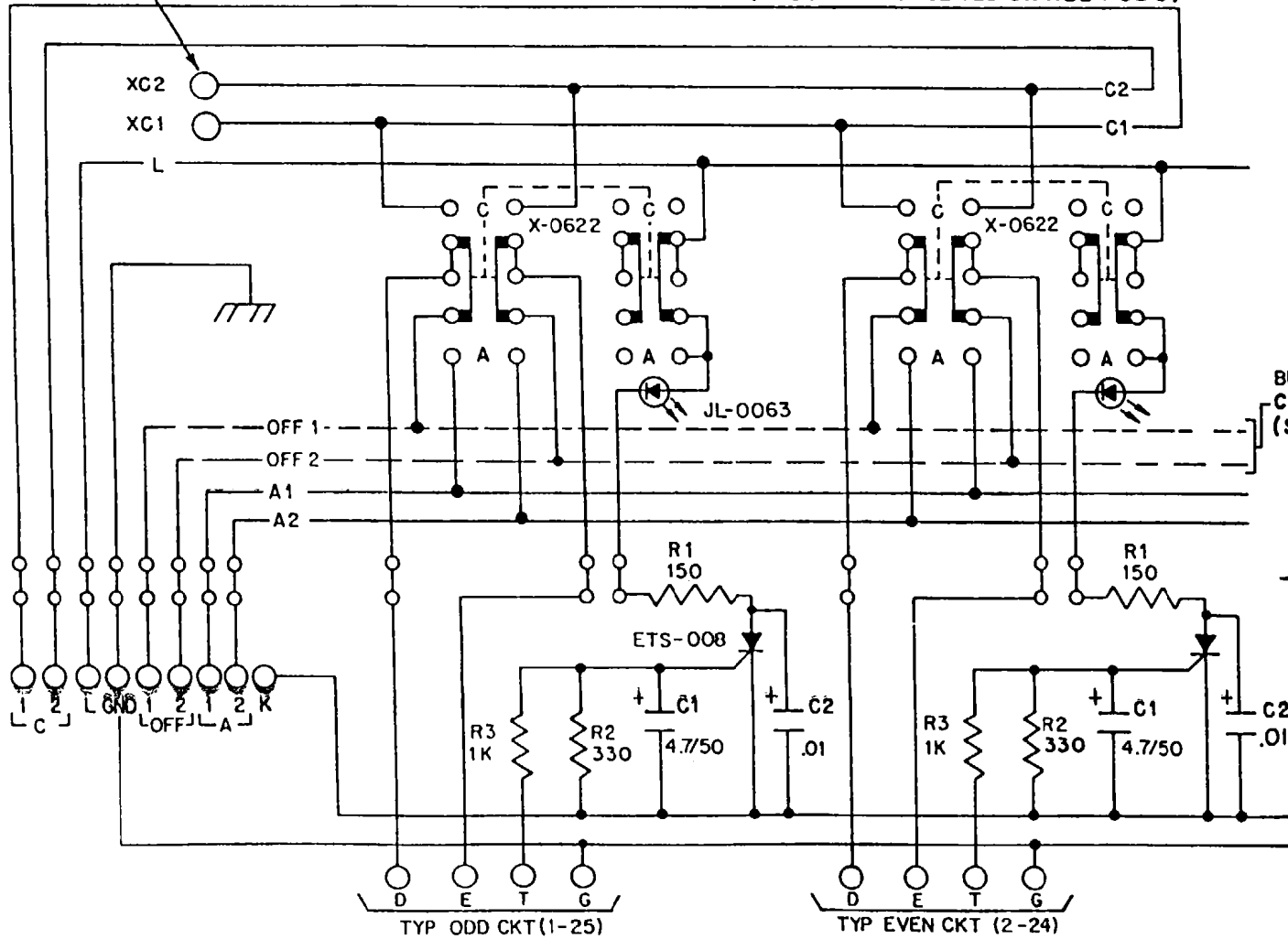

BUSING STRIPS CAN BE MODIFIED (SEE MANUAL).

FRONT P.C. ASSEMBLY
 REAR P.C. ASSEMBLY

SWL 25 SWITCHBANK
 RAULAND-BORG CORP.
 SKOKIE, ILL.
 MADE IN U.S.A.
 KC1335 [B]