



DAX60 60-WATT POWER AMPLIFIER
 DAX120 120-WATT POWER AMPLIFIER
 INSTALLATION AND SERVICE

RAULAND-BORG CORPORATION • 3450 West Oakton Street, Skokie, Illinois 60076-2951 • (708) 679-0900

GENERAL DESCRIPTION

The Rauland DAK Series amplifiers are designed for use with Rauland's institutional program and communication systems. They offer high-quality sound and dependability. They can be driven to their rated power output by an input signal as low as **0.3** volts. Their transformer-isolated, 25-volt balanced output matches the output of Rauland's communication panels; they also have a 70.7-volt balanced output. Their outputs can operate with a split center tap with Rauland's Telecenter® 5000 and Responder® 3000 systems. The amplifiers are listed by Underwriters Laboratories,

The DAX amplifiers offer helpful power connections for related equipment: three 120-VAC three-pin grounded outlets, and a floating auxiliary DC power output (28 VDC, 1.2 A) that can be used for Rauland's Director Series control panels, preamplifiers, graphic equalizer, and other equipment.

The amplifiers come with black-enamel face panels. Optional brushed-chrome dress panels--the RP2525 (DAX60) and RP2700 (DAX120)--are available.

UNPACKING

The amplifier was thoroughly checked at the factory. Inspect the amplifier, the enclosed parts, and the shipping container for signs of improper handling during shipment. In case of damage, immediately place a claim: with the dealer or distributor from whom you purchased the unit or--if the unit was shipped directly to you--with the carrier.

The following parts are included with the amplifier:

<u>Description</u>	<u>Rauland Part No.</u>
4 Rack-Mounting Screws for tapped holes (10-32 x ½" hex-head, SEMS, unslotted, machine).	WA202
4 Rack-Mounting Screws for untapped holes (10 x ½" pan-head, slotted, thread-forming).	WA102
4 #10 Tinnerman "U" type Speed Nuts, for untapped rack holes.	AB1889

INSTALLATION

The amplifier should be rack-mounted where there is adequate ventilation, a moderate temperature, an AC power outlet, and provisions for grounding.

The rack should have the standard 19-inch width and a vertical space of at least 5¼ inches (DAX60) or 7 inches (DAX120). It is recommended that addition-

al space be left above and below the amplifier to prevent hum from being introduced into adjacent equipment (such as preamplifiers), to provide additional ventilation, and to allow easier access for servicing. Adding an inch of space behind the amplifier for connections, the rack should have a total depth of seven inches. A cooling fan is recommended when the rack is enclosed and any of the following conditions obtains:

- (a) The combined rated output power of all the equipment exceeds 250 watts RMS; OR
- (b) The input from the AC power line exceeds 500 watts; OR
- (c) Restricted air flow in the rack may create extreme heat.

CAUTION

FAILURE TO OBSERVE THE PRECEDING PRECAUTIONS COULD RESULT IN OVERHEATING THAT COULD DAMAGE THE EQUIPMENT OR CREATE A FIRE HAZARD.

Rack-Mounting

The DAK Series amplifiers are designed to be mounted into a standard 19-inch rack. #10 "U" nuts (AB1889) and two kinds of mounting screws are supplied with each amplifier.

- A. If the rack's holes are untapped, select the #10 thread-forming screws (WA102). Push the #10 "U" nuts, their flat side facing outward, onto the proper holes in the rack (you may have to leave the "U" nuts off if the holes are extruded).
- B. If the rack's holes are tapped, select the #10 machine screws (WA202).

Turret-Mounting (DAX60 only)

The rack-mounting procedures can be used to install the DAX60 in a Rauland Control Turret. However, if the turret's internal rails are used and the amplifier is oriented with its front panel facing the rear of the turret, an optional MK10 Mounting Kit will be needed. This special-order kit must be installed by the factory.

WARNING

DO NOT CONNECT AC POWER TO THE AMPLIFIER UNTIL ALL OF THE NECESSARY INPUT AND OUTPUT CONNECTIONS HAVE BEEN COMPLETED.

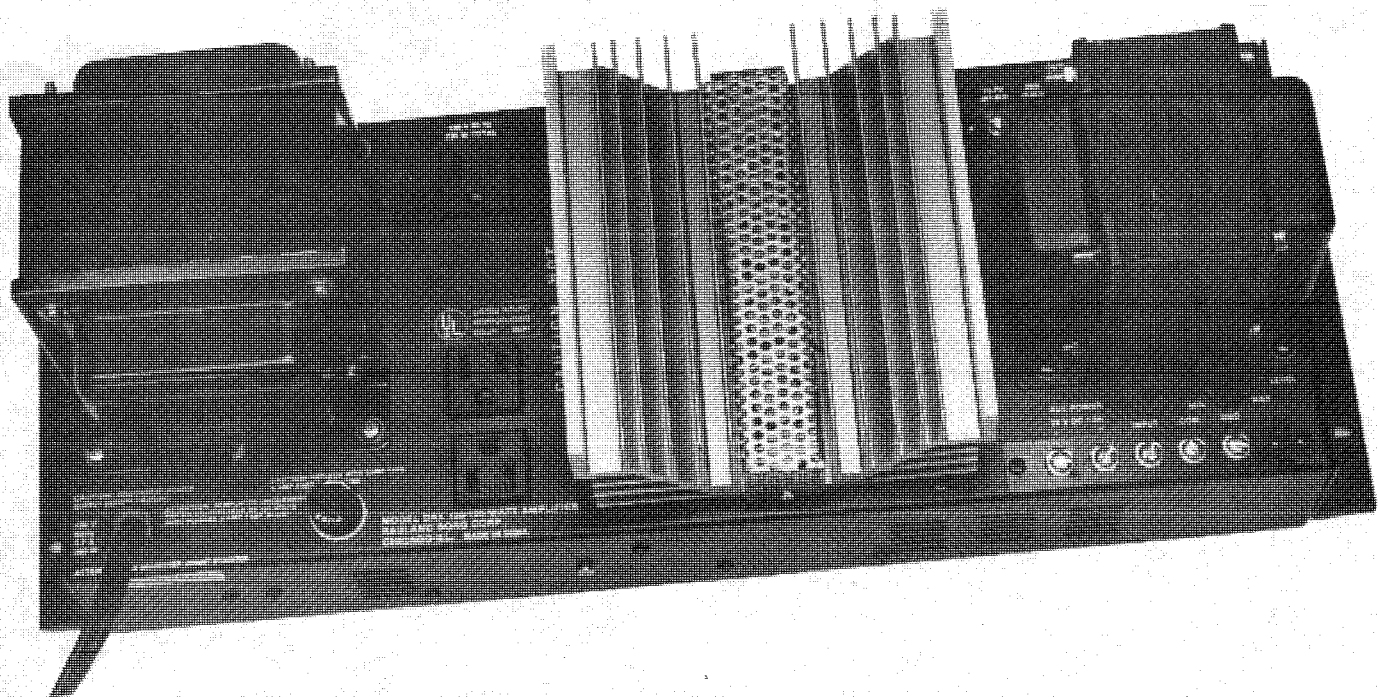

Figure 1. DAX120 Power Amplifier (rear view)

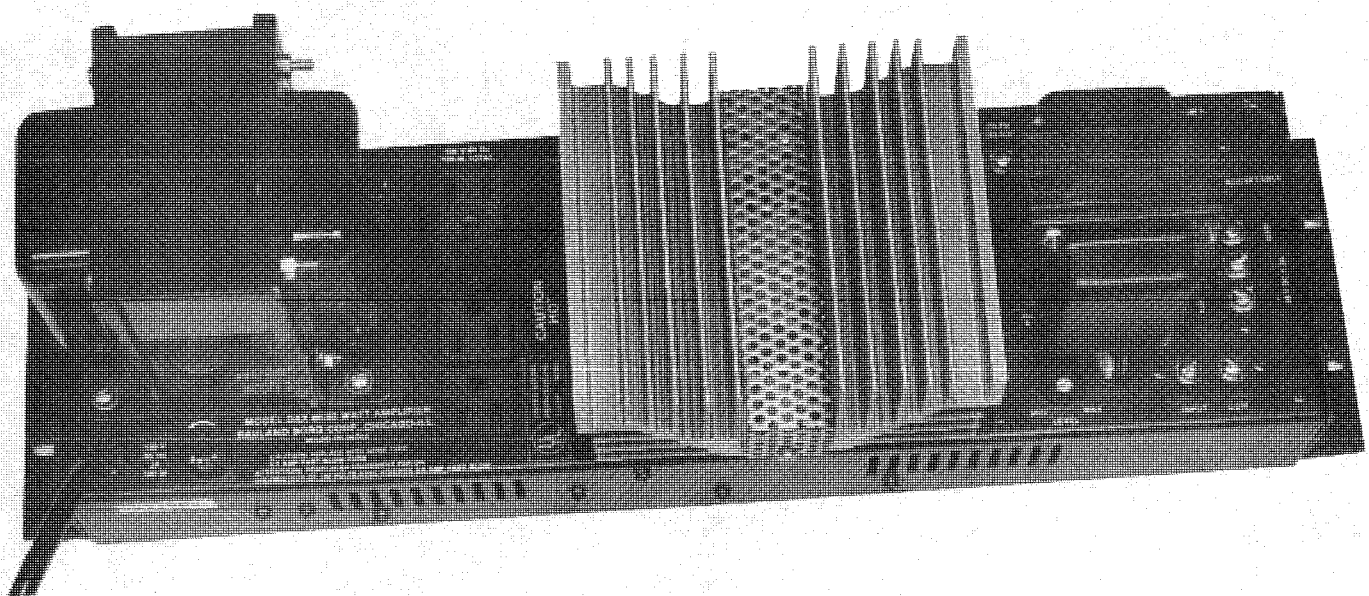

Figure 2. DAX60 Power Amplifier (rear view)

Grounding

CAUTION

DO NOT DISCONNECT THE THIRD WIRE ON THE POWER PLUG. THIS WIRE GROUNDS THE AMPLIFIER'S CHASSIS TO PREVENT A POSSIBLE SHOCK HAZARD. IF AN ADAPTER IS USED TO CONNECT THE PLUG TO A TWO-PRONG SOCKET, MAKE SURE THAT THE AMPLIFIER'S CHASSIS IS CONNECTED TO A PROVEN EARTH GROUND.

INPUT CONNECTIONS

The input is unbalanced. The input screw terminals are labeled "COM" (-) and "INPUT" (+), respectively. The terminal strip is located on the lower right corner, as viewed from the rear of the chassis. The signal source should deliver at least 300 millivolts into a 13-kilohm load.

Route the input cables as far from the speaker cables as possible, to prevent coupling.

OUTPUT CONNECTIONS

The output screw terminals are located on the upper right corner, as viewed from the rear of the chassis. The following illustration shows how the output transformer's split windings are connected with a factory-installed link for most applications (for applications with the link removed, see "Split-Center-Tap Operation," below).

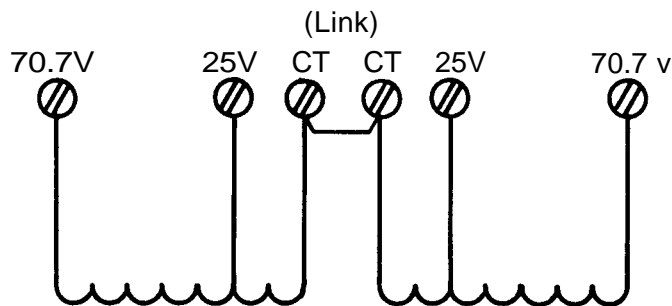

VOLTAGE TAPS OF THE DAX SERIES AMPLIFIERS
IL0252

The output impedances are as follows:

DAX60: 70.7V = 83.3 ohms; 25V = 10.4 ohms.

DAX120: 70.7V = 41.6 ohms; 25V = 5.2 ohms.

Selecting Balanced or Unbalanced Output Connections

The balanced outputs for 70.7 volts and 25 volts are for speakers designed for constant-voltage lines. Each speaker must have a line-matching transformer, and the speakers must be connected in parallel. The impedance taps on the primaries of the line-matching transformers indicate how much power will be taken from the line. Speakers can be added as required until the total wattage absorbed by all of the transformers is equal to the rated power output of the amplifier. However, it is good practice to allow an amplifier a headroom of 10% to 20%. For a 60-watt amplifier, the maximum speaker load should be approximately 50 watts; for a 120-watt amplifier, the maximum speaker load should be approximately 100 watts.

For unbalanced operation, place a jumper between one of the speaker terminals you are using and "GND." Do not ground the center tap when you use unbalanced operation.

Grounding the Center Tap

If required by the installation, the center-tap terminals may be jumpered to the "GND" terminal when the BALANCED speaker output is used. The "GND" terminal is next to the negative "AUX POWER" terminal on the DAX60; on the DAX120, the "GND" terminal is next to the "COM" input terminal. When the two center-tap terminals are linked together, either one of them may be connected to the "GND" terminal.

DO NOT INSTALL A JUMPER BETWEEN "GROUND" AND "CT" WITH THE UNBALANCED SPEAKER CONNECTION: CONNECTING BOTH POINTS TO "GROUND" WOULD CREATE A SHORT CIRCUIT ACROSS THE OUTPUT TRANSFORMER.

Split-Center-Tap Operation

The amplifier output transformer can be configured for split-center-tap operation with symmetrical output voltages on both sides of the center tap. This is intended for special applications with Rauland systems such as the Telecenter 5000 and the Responder 3000. When a DAX amplifier is used with the TC5000 or the NCS3000, (a) no more than 50 watts of power may be drawn through the system, and (b) a TC5007 Transformer Module is required (see KI-1486).

If the installation requires an isolated, split-center-tapped output, remove the supplied link from the two "CT" terminals: this will separate the two halves of the output windings (see "OUTPUT CONNECTIONS," above, and the attached KM0780).

Note: There is a large capacitor inside the TC5000 and the NCS3000 that provides a low AC impedance across the center taps. The split windings are not designed to be used independently.

Auxiliary DC Power Supply

The 28-VDC terminals (on the right side of the DAX60, below the output transformer of the DAX120) can provide up to 1.2 Amperes to preamplifiers, Director Series control panels, and other auxiliary devices requiring DC power. Since this supply is floating, it can also be used for devices requiring an

isolated power source, such as Rauland's Model 6430 Pink-Noise Source and Model 6431 1/3-Octave Equalizer. Do not mix floating and grounded accessories.

POWER CONNECTION

Plug the power cord into a 120-V, 60-HZ, three-wire grounded outlet that can provide at least 935 watts (DAX60) or 1105 watts (DAX120). Although the amplifier circuits by themselves consume no more than 175 watts (DAX60) or 345 watts (DAX120), connecting another device to the DC output could consume another 40 watts of power, and a total load of 720 watts could be connected to the three AC sockets. Check the local regulations before installing permanent AC lines and plugging in the equipment.

Converting the Amplifiers to 240 VAC

If operation from a 240-VAC power source is desired, remove the front cover and locate the "120V/240V" switch inside the amplifier, on the right. Use a small screwdriver to slide the switch to the "240V" side. Resecure the front cover. Replace the fuse with a fast-blow, 240-volt fuse with half the current rating of the supplied fuse; the new value would be 1.25 Amps for the DAX60, 2.5 Amps for the DAX120 (see "REPLACING THE FUSE," below). Replace the plug on the power cord with one approved for 240-VAC operation.

CAUTION: When the amplifier is connected to a 240-volt supply, its three "120 VAC" convenience outlets will supply 240 volts. Accordingly, they should not be used when the amplifier is connected to 240 volts.

SETTING THE "INPUT LEVEL" CONTROL

The input-level control, marked "LEVEL" on the rear chassis below the output transformer (see Figure 1), can be adjusted with a ¼-inch flat-blade screwdriver: turning the control clockwise will increase the output level. This control should be set so that the maximum possible input signal will not cause the output to clip. After this control has been adjusted by the installer, it should be left alone.

REPLACING THE FUSE

A current surge during operation may cause the fuse to blow. To restore power to the amplifier, first ascertain what the problem is and correct it before replacing the fuse. Use a fast-blow fuse: 2.5 Amps for the DAX60, 5 Amps for the DAX120 (but only half of these values if the amplifier is operating from a 240-VAC line).

The fuse holder is on the rear of the amplifier, below the power transformer. You will need a Phillips screwdriver to remove the center plug; you may find a scissors-nosed pliers helpful in removing the fuse. If the replacement fuses continue to blow, unplug the amplifier and consult a qualified service representative.

INITIAL TROUBLESHOOTING

<u>Problem</u>	<u>Possible Causes</u>
1) Low volume or distorted sound.	<p>(a) Check whether all the input and output connections are properly made and securely fastened.</p> <p>(b) If the sound is distorted, check whether the speakers are being overdriven (e.g., does the distortion go away when the level control is turned down?).</p>
2) The amplifier does not operate.	<p>(a) Make sure that the power cord is plugged in and that there is power in the outlet.</p> <p>(b) Examine the input and output lines for (1) obvious shorts (among themselves and between them and the chassis or surrounding equipment) and (2) broken connections.</p> <p>(c) If everything appears in order, try replacing the fuse. If the amplifier still fails to respond, unplug the power cord and contact your local Rauland distributor.</p>
3) The 28-VDC output cycles off and on, or it remains off.	<p>(a) There are two circuit breakers protecting this output. CB2 is a 1.6-Amp thermal breaker that shuts down the circuit when the DC current flow significantly exceeds the output's 1.2-Ampere rating, then automatically resets. It will continue cycling off and on until the problem is corrected. If the amplifier remains off, CB1 (3.15 Amps) may have tripped. Check for a short in the connections, then try manually resetting CB1 by poking a small screwdriver through the access hole in the front cover (at the upper left corner of the DAX60, or the lower left corner of the DAX120)).</p> <p>(b) If the problem does not lie in the load or the connections, one of the breakers may be defective. Disconnect the load and call your Rauland distributor.</p>

SERVICING INFORMATION

THE INFORMATION THAT FOLLOWS IS INTENDED FOR QUALIFIED SERVICE TECHNICIANS.

Locating the Test Points

Whenever possible, take the voltage readings on the large connector on the main printed circuit board. You will have to remove the front cover to access it.

The DAX60 has a single 16-pin connector labeled "T" on the schematic; the pins are numbered from bottom to top on the board.

The DAX120 has two 16-pin connectors: the top connector and the top half of the bottom connector are referred to as "J1" on the schematic, and the rest of the bottom connector is referred to as "J2" on the schematic. The pins are numbered 1-24 and 1-8, from top to bottom on the board.

Measuring DC Voltages

DC voltages are printed in rectangular boxes at various points on the schematic. When measuring these voltages on the amplifier, use a DC meter with a resistance of 1 megohm per volt and proceed as follows:

Step 1. Place the amplifier on a suitable work surface and make sure that no signal is present at the input terminals. Disconnect the speakers and connect a suitable resistive load in their place:

DAX60: The load should have at least a 60-watt power rating and a value of 10.4 ohms across the 25-volt output or 83.3 ohms across the 70.7-volt output).

DAX120: The load should have at least a 120-watt power rating and a value of 5.2 ohms across the 25-volt output or 41.6 ohms across the 70.7-volt output).

Step 2. Plug the amplifier into a 120-VAC, 60-HZ source.

Step 3. On the DAX60: Connect the meter's negative lead to the amplifier common at Connector "T-14." As you locate each DC voltage on the schematic, note the number of the nearest "T" terminal in that leg of the circuit and, if possible, take the readings between such a "T" terminal and "T-14."

On the DAX120: Connect the meter's negative lead to the amplifier common at Connector "J1-13." As you locate each DC voltage on the schematic, note the number of the nearest "J" terminal in that leg of the circuit and, if possible, take the readings between such a "J" terminal and "J1-13."

Measuring AC Voltages

AC voltages are printed without boxes at various points on the schematic. When measuring these voltages on the amplifier, use an AC meter with a one-megohm impedance and proceed as follows:

Step 1. Place the amplifier on a suitable work surface. Disconnect the speakers and replace them with a suitable resistive load:

DAX60: The load should have at least a 60-watt power rating and a value of 10.4 ohms across the 25-volt output (or 83.3 ohms across the 70.7-volt output).

DAX120: The load should have at least a 120-watt power rating and a value of 5.2 ohms across the 25-volt output or (41.6 ohms across the 70.7-volt output).

Step 2. Disconnect any input device and connect a one-kilohertz signal source in its place. The source should be able to provide an amplitude of approximately 300 millivolts. Leave its output level turned down.

Step 3. Plug the amplifier into a 120-VAC, 60-HZ source. Turn the input-level control fully clockwise, for maximum gain.

Step 4. Connect the test leads across the 25-V or 70.7-V outputs. Slowly increase the output from the 1-KHz signal source until you obtain the rated output voltage from the DAK. Check the input level required to obtain the rated output: a reading of 300 millivolts or less is an indication that the amplifier gain is functioning properly.

Step 5. On the DAX60: Connect the meter's negative lead to the amplifier common at Connector "T-14." As you locate each AC voltage on the schematic, note the number of the nearest "T" terminal in that leg of the circuit and, if possible, take the readings between such a "T" terminal and "T-14."

On the DAX120: Connect the meter's negative lead to the amplifier common at Connector "J1-13." As you locate each AC voltage on the schematic, note the number of the nearest "J" terminal in that leg of the circuit and, if possible, take the readings between such a "J" terminal and "J1-13."

Locating the Driver and Power Transistors

On both amplifiers, driver transistors Q505 and Q506 are screwed to the "L" bracket that is fastened to the large heat sink from inside the chassis. The power transistors (Q507-Q508 on the DAX60, Q501-Q504 on the DAX120) are fastened directly to the large heat sink from the outside (to access them, remove the protective cover). The transistors are numbered in ascending order, with the lowest number at the bottom.

Removing and Replacing Transistors

Transistors are inherently long-lived devices that normally should not need replacement. If, however, systematic troubleshooting indicates a problem, observe these precautions when removing and replacing transistors:

- (1) Transistors can be damaged by excessive heat, so use a small soldering iron when removing or replacing a transistor with solder connections.
- (2) Transistors come with a wide variety of cases and leads. To avoid a costly mistake, make a careful sketch of the lead connections before removing a transistor from a printed circuit board or tie points.

(3) Before installing a power transistor (Q507-Q508 on the DAX60, Q501-Q504 on the DAX120), obtain an appropriate Silpad® insulator. If a mica insulator is used instead, coat both sides of it with silicone grease (Dow-Corning DC4 or an equivalent). Fit the insulator between the transistor and the heat sink, as shown below.

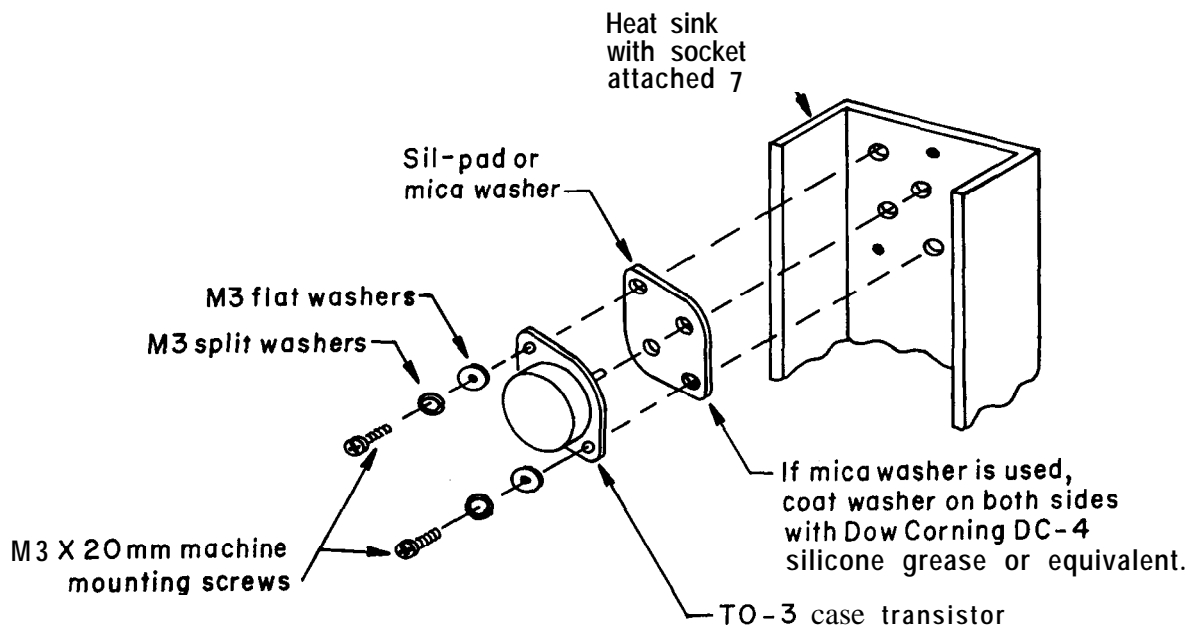

1L0253

After installing a power transistor, check for a short circuit:

Step 1. On the DAX120, isolate the circuit common from the chassis by disconnecting the wire between the negative side of C503 (the large electrolytic capacitor nearest the auxiliary 120-VAC outlets) and the star connector at the right end of the amplifier (as viewed from the front). This capacitor is not grounded to the chassis in the DAX60.

Step 2. Use an ohmmeter to check for a short between the transistor case and the heat sink. If there is a low-resistance reading, check the insulator, the screws, etc., as possible causes.

Step 3. After obtaining a high-resistance reading (at least 100 kilohms) between each transistor case and the heat sink, re-establish the connection between the negative side of C503 and the star connector (DAX120 only).

Testing Transistors

The best way to test a transistor is to use a transistor tester. However, if one is not available, use an ohmmeter. Most failures result in a short or an open circuit between the collector and the emitter.

Connect the ohmmeter's leads to the collector and the emitter, then use the low ohm range **to** read the resistance. If the reading in this range remains the same when the leads are reversed, the transistor is shorted. If the readings are "infinite" for both connections, the transistor is open.

DAX60 Circuit Description

Refer to the attached schematic, KC1546, to trace the circuit descriptions that follow.

Input and Preamplifier Circuits: Resistor R1 and Capacitors C1 and C507 reject Radio Frequency Interference (RFI). RV1 is the input LEVEL control (potentiometer), which controls the signal level that is applied to the DAX's preamplifier circuits. Capacitors C2 and C8 govern the low-frequency response of the input signal, to protect horn-type speakers. Transistor Q1 is a common-emitter amplifier that provides the preamplifier gain. It is also a common-base inverter for the feedback entering its emitter.

Power-Amplifier Circuits: Transistor Q2 is a high-voltage-gain amplifier that drives Transistors Q3 and Q4. The latter are phase splitters that form a unity-gain configuration. Diode D503 is a negative-temperature-coefficient device mounted on the heat sink. This diode controls the DC bias for the drive and the output transistors. Transistors Q505 and Q506 are current amplifiers (drivers) that supply high base current to the output transistors, Q507 and Q508. The latter are push-pull power amplifiers that drive the output transformer. Capacitor C506 blocks DC from the output transformer and limits the low-frequency output to protect horn-type speakers.

Protective Circuits: There are several protections against excessive current. Resistors R16 and R19 are current limiters; if a short occurs across the audio output, each resistor will drop 10 VDC. An excessive current surge will cause the fuse to open. In the 28-VDC supply, a short circuit on the DC output or a DC load that draws significantly more current than 1.2 Amperes will cause Thermal Breaker CB2 to open within 70 seconds. It will try to reset within 15 seconds, then continue opening and closing until the short or the excessive load is removed, at which time it will remain closed for normal operation. A more serious problem will cause CBI to open; it must be reset manually.

DAX120 Circuit Description

Refer to KC1547 (attached) to trace the circuit descriptions that follow.

Input and preamplifier circuits: Resistor R1 and Capacitors C1 and C507 filter Radio Frequency Interference (RFI). RV1 is the input LEVEL control (potentiometer), which controls the signal that is applied to the preamplifier circuits. Capacitors C2 and C9 govern the low-frequency response of the input signal, to protect horn-type speakers. Transistor Q1 is a common-emitter amplifier that provides the preamplifier gain. It is also a common-base inverter for the feedback entering its emitter. Q2 is an emitter follower.

Power-amplifier circuits: Transistor Q3 is a high-voltage-gain amplifier that drives Transistors Q5 and Q6. The latter, operating as phase splitters in a unity-gain configuration, provide the drive for Transistors Q505 and Q506. Q505 and Q506 are the drivers for the output transistors (Q501-Q504). Diode D503 is a negative-temperature-coefficient device mounted on the heat sink. This diode controls the DC bias for the driver and output transistors. Transistors Q501 through Q504 are push-pull power amplifiers that drive the output transformer. Capacitor C505 blocks DC from the output transformer and limits the low-frequency output to protect horn-type speakers.

Protective circuits: There are several protections against excessive current. Transistors Q4 and Q7 are current limiters. If a short occurs across the audio output, the following sequence of events will occur: (1) the DC voltage across Resistors R29 and R32 will drop; (2) this drop will drive Transistors Q4 and Q7 into conduction; (3) the output of Q4 and Q7 will limit the drive to Transistors Q5 and Q6; and (4) the reduced output from Q5 and Q6 to the power transistors will reduce the overall gain (and, thereby, the total power) of the amplifier. An excessive current surge will cause the fuse to open. In the 28-VDC supply, a short circuit on the DC output or a DC load that draws significantly more current than 1.2 Amperes will cause Thermal Breaker CB2 to open within 70 seconds. It will try to reset within 15 seconds, then continue opening and closing until the short or the excessive load is removed, at which time it will remain closed for normal operation. A more serious problem will cause CB1 to open; it must be reset manually.

SPECIFICATIONS

Rated Power Output: DAX60: 60 watts RMS. DAX120: 120 watts RMS.

Frequency Response: ±1.5 db from 40 Hz to 15 kHz at -3 db from RPO.

Harmonic Distortion: Less than 3% from 60 Hz to 15 kHz.

Noise Level: -84 dB with LEVEL control at maximum setting.
 -90 dB with LEVEL control at minimum setting.

Input Impedance: 13 kilohms.

Input Sensitivity
for Rated Power Output: 0.3 v.

Power Requirements: DAX60: 105-130 VAC, 60 Hz, 935 watts (including the
 AC and DC outputs).
DAX120: 105-130 VAC, 60 Hz, 1105 watts (including the
 AC and DC outputs).

Auxiliary DC Output: Supplies 1.2 Amperes at 28 VDC.

AC Power Consumption: With 28 VDC Auxiliary Output Disconnected:

	DAXGO	DAX120
No signal	12 watts	12 watts
1/3 RPO	105 watts	210 watts
Full RPO	175 watts	345 watts

With 28 VDC Auxiliary Output Fully Loaded:

	DAXGO	DAX120
No signal	50 watts	50 watts
1/3 RPO	145 watts	250 watts
Full RPO	215 watts	385 watts

AC Convenience Outlets: 720 watts maximum.

Operating Temperature: 0" F to 130" F (-17.8" C to 54.4" C).

Line Protection: Fast-blow fuse: 2.5A (DAX60), 5A (DAX120).

28 VDC Protection: 1.6-Amp thermal breaker, automatically reset;
 3.15-Amp breaker, manually reset.

Size: DAXGO: 19" W, 5-1/4" H, 6-1/2" D (48.3 cm x 13.3 cm x
 16.5 cm).
DAX120: 19" W, 6-3/4" H, 6-1/2" D (48.3 cm x 17.2 cm
 x 16.5 cm).

Unit Weight: DAXGO: 23 lb. (10.42 kg). DAX120: 27 lb (12.23 kg).

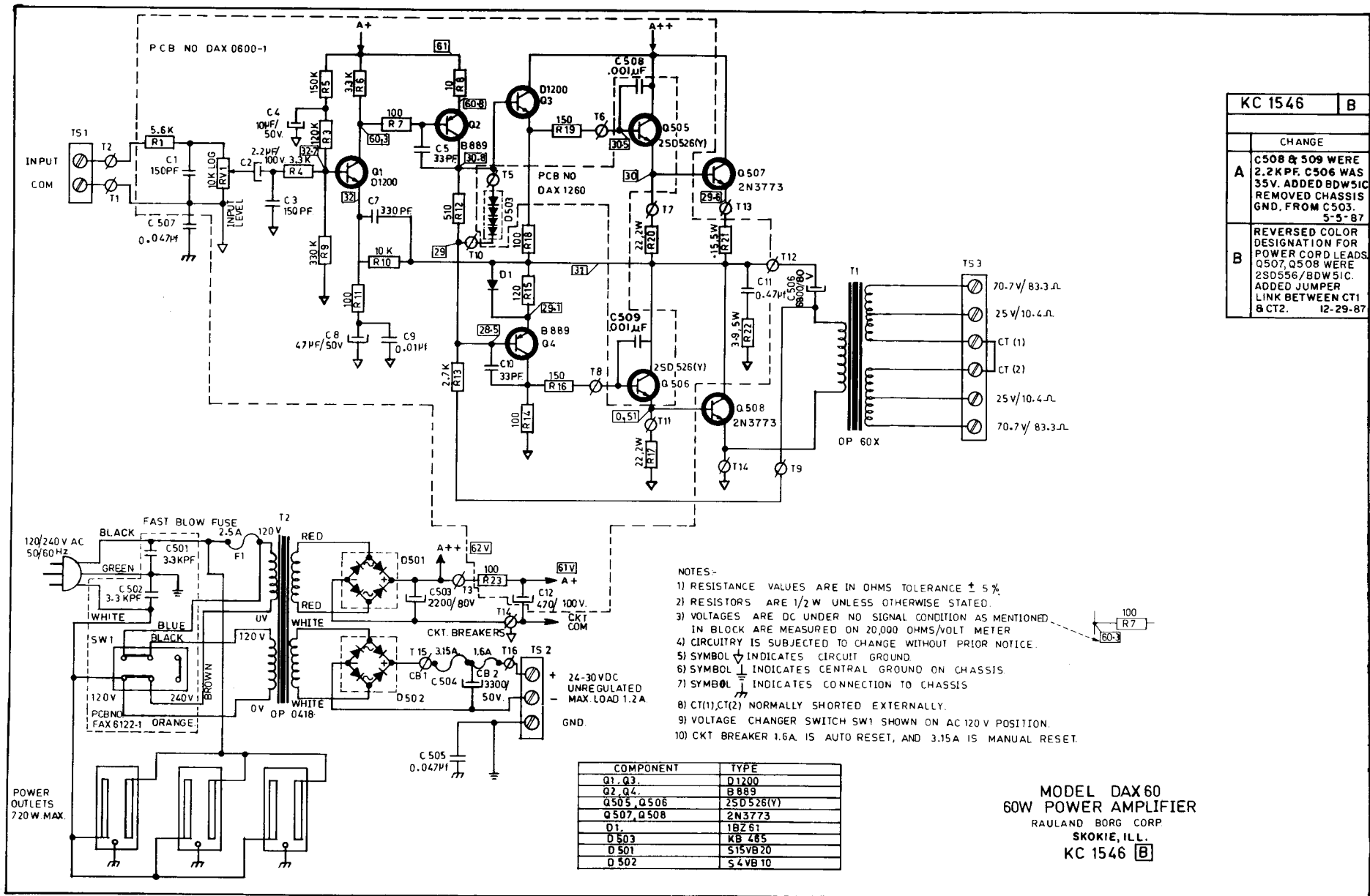

KC 1546		B
CHANGE		
A	C508 & 509 WERE 2.2K PF. C506 WAS 35V. ADDED BDW51C REMOVED CHASSIS GND. FROM C503. 5-5-87	
B	REVERSED COLOR DESIGNATION FOR POWER CORD LEADS. Q507, Q508 WERE 2SD556/BDW51C. ADDED JUMPER LINK BETWEEN CT1 & CT2. 12-29-87	

- NOTES-
- 1) RESISTANCE VALUES ARE IN OHMS TOLERANCE $\pm 5\%$
 - 2) RESISTORS ARE 1/2 W UNLESS OTHERWISE STATED.
 - 3) VOLTAGES ARE DC UNDER NO SIGNAL CONDITION AS MENTIONED IN BLOCK ARE MEASURED ON 20,000 OHMS/VOLT METER
 - 4) CIRCUITRY IS SUBJECTED TO CHANGE WITHOUT PRIOR NOTICE.
 - 5) SYMBOL ∇ INDICATES CIRCUIT GROUND
 - 6) SYMBOL \perp INDICATES CENTRAL GROUND ON CHASSIS
 - 7) SYMBOL \oplus INDICATES CONNECTION TO CHASSIS
 - 8) CT(1), CT(2) NORMALLY SHORTED EXTERNALLY.
 - 9) VOLTAGE CHANGER SWITCH SW1 SHOWN ON AC 120 V POSITION.
 - 10) CKT BREAKER 1.6A IS AUTO RESET, AND 3.15A IS MANUAL RESET.

COMPONENT	TYPE
Q1, Q3.	D1200
Q2, Q4.	B889
Q505, Q506	2SD526(Y)
Q507, Q508	2N3773
D1.	1BZ61
D503	KB Z85
D501	S15VB20
D502	S4VB10

MODEL DAX 60
 60W POWER AMPLIFIER
 RAULAND BORG CORP.
 SKOKIE, ILL.
 KC 1546 B

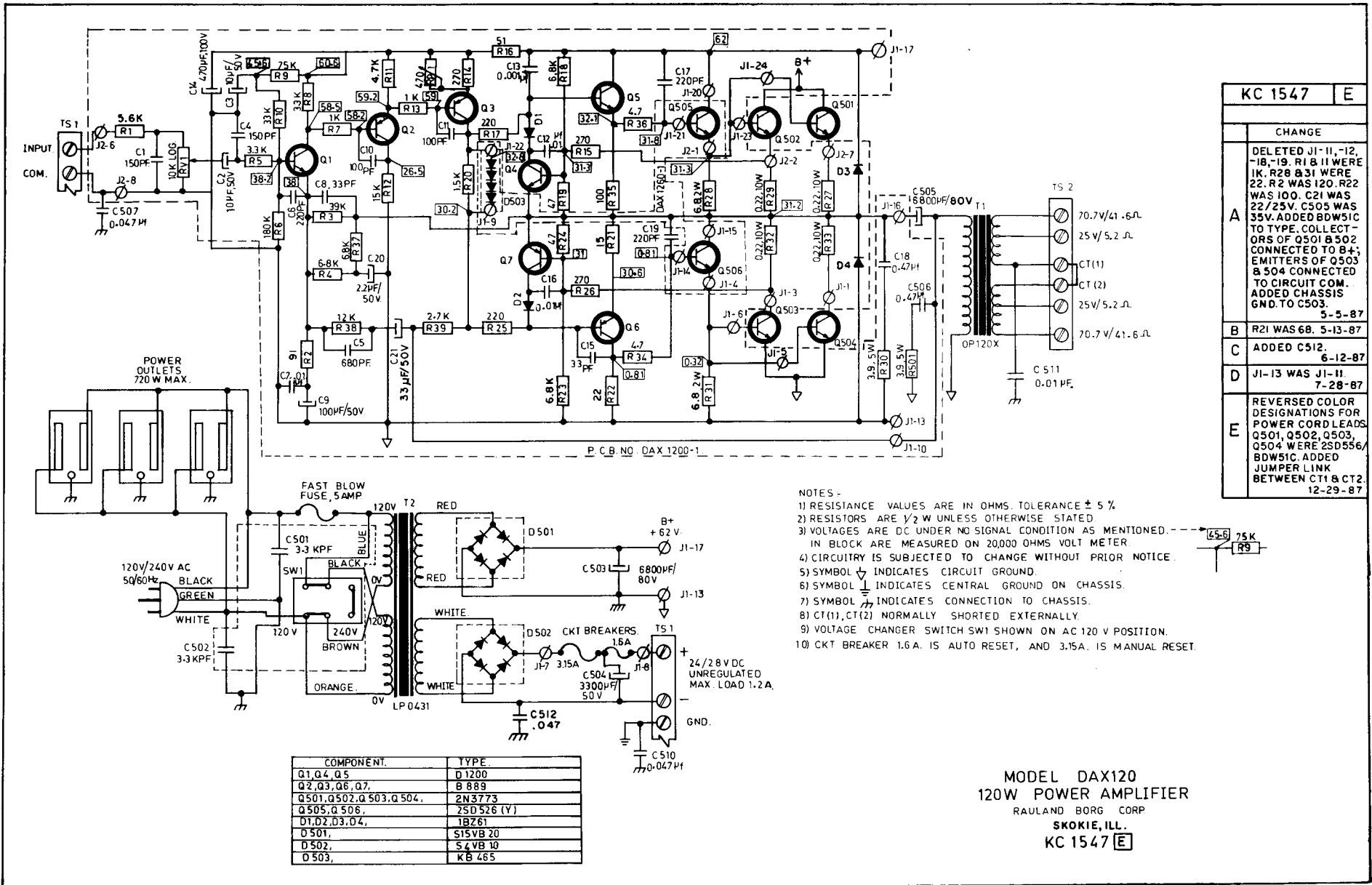

KC 1547		E
CHANGE		
A	DELETED J1-11, -12, -18, -19. R1 & R11 WERE 1K. R28 & R31 WERE 22. R2 WAS 120. R22 WAS 100. C21 WAS 22/25V. C505 WAS 35V. ADDED BDW51C TO TYPE. COLLECTORS OF Q501 & Q502 CONNECTED TO B+; EMITTERS OF Q503 & Q504 CONNECTED TO CIRCUIT COM. ADDED CHASSIS GND TO C503.	5-5-87
B	R21 WAS 68.	5-13-87
C	ADDED C512.	6-12-87
D	J1-13 WAS J1-11.	7-28-87
E	REVERSED COLOR DESIGNATIONS FOR POWER CORD LEADS. Q501, Q502, Q503, Q504 WERE 2SD556/BDW51C. ADDED JUMPER LINK BETWEEN CT1 & CT2.	12-29-87

- NOTES -
- 1) RESISTANCE VALUES ARE IN OHMS. TOLERANCE $\pm 5\%$
 - 2) RESISTORS ARE $\frac{1}{2}$ W UNLESS OTHERWISE STATED
 - 3) VOLTAGES ARE DC UNDER NO SIGNAL CONDITION AS MENTIONED. --- IN BLOCK ARE MEASURED ON 20000 OHMS VOLT METER
 - 4) CIRCUITRY IS SUBJECTED TO CHANGE WITHOUT PRIOR NOTICE.
 - 5) SYMBOL ∇ INDICATES CIRCUIT GROUND.
 - 6) SYMBOL \perp INDICATES CENTRAL GROUND ON CHASSIS.
 - 7) SYMBOL --- INDICATES CONNECTION TO CHASSIS.
 - 8) CT(1), CT(2) NORMALLY SHORTED EXTERNALLY.
 - 9) VOLTAGE CHANGER SWITCH SW1 SHOWN ON AC 120 V POSITION.
 - 10) CKT BREAKER 1.6A IS AUTO RESET, AND 3.15A IS MANUAL RESET.

MODEL DAX120
120W POWER AMPLIFIER
RAULAND BORG CORP
SKOKIE, ILL.
KC 1547 E

DRG. NO.		KM0780		B	
DATE		10-3-86			
ISS		CHANGE			
A		CHANGED SHIELDED WIRE NOTE TO UNBALANCED & BALANCED INPUT. SPN 7-14-87			
B		ADDED TC5000 NOMENCLATURE SPN 2-3-88			

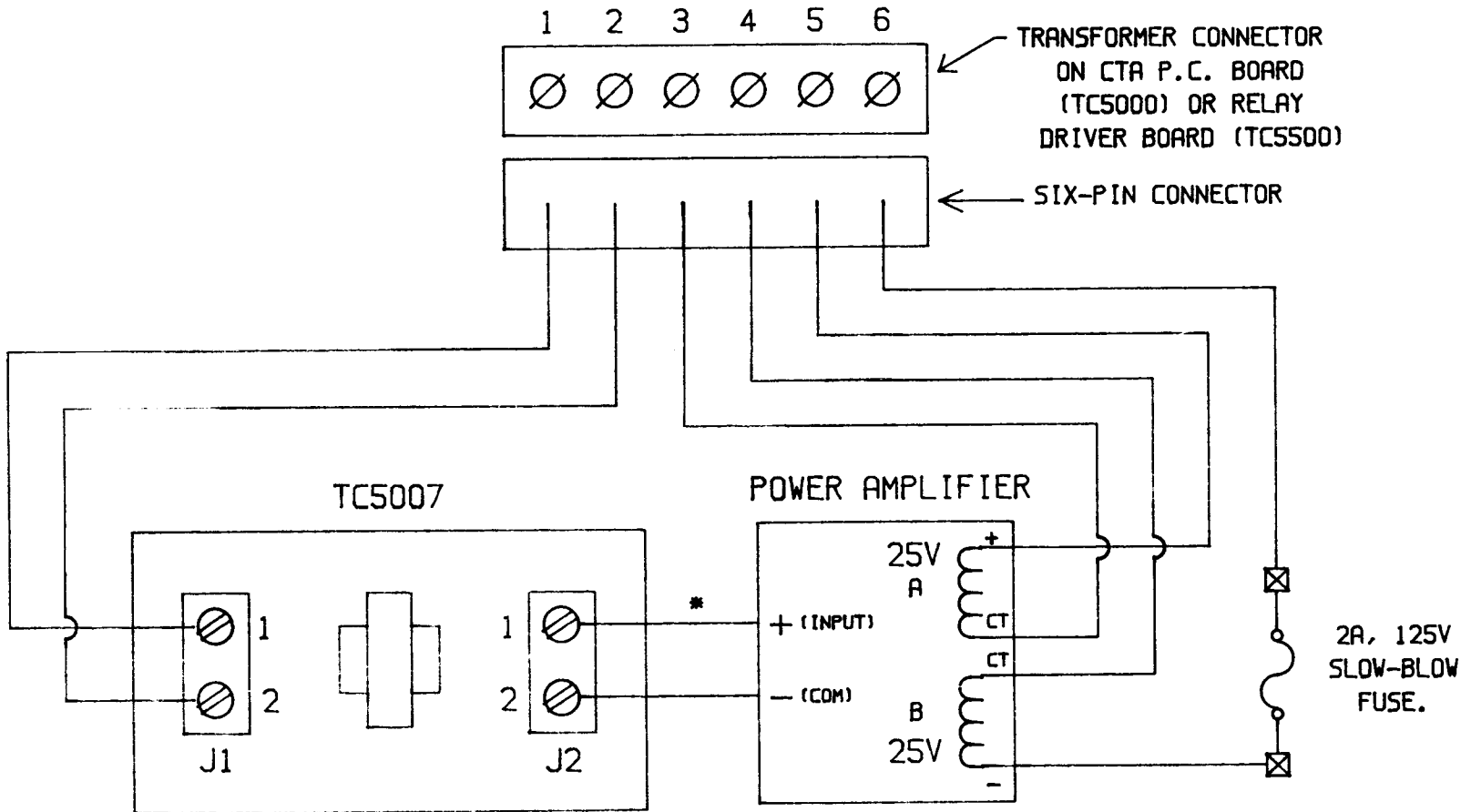

* **UNBALANCED INPUT:** USE A SINGLE SHIELDED WIRE; CONNECT THE SHIELD TO "COMMON."

BALANCED INPUT: USE A SHIELDED PAIR; TIE THE SHIELD TO THE AMPLIFIER CHASSIS.

IMPORTANT:
 MOST AMPLIFIERS DO NOT HAVE A SPLIT-WINDING OUTPUT TRANSFORMER. TO USE A CONVENTIONAL AMPLIFIER OUTPUT, CONNECT A TC5008 BETWEEN IT AND THE TC5000 (SEE KI-1487).

USING A TC5007
 TRANSFORMER MODULE
 TO CONNECT
 AN EXTERNAL PAGING AMPLIFIER
 TO THE TC5000 OR TC5500
 KM0780-B