

OPERATING INSTRUCTIONS

POWER

Depress POWER ON button to turn on tuner. Turn off tuner by depressing button again to release it to the out position.

AM RECEPTION

Depress AM button. Turn TUNING knob until pointer indicates desired station on AM (bottom) dial. Adjust TUNING knob until needle on tuning meter shows maximum deflection to right.

FM RECEPTION

Depress FM and FM MUTE buttons. Turn TUNING

knob until pointer indicates desired station on FM (top) dial. Carefully adjust TUNING knob until needle on tuning meter is at the center of the tuning dial, exactly on the circle above the letters "FM".

NOTE

Muting removes the annoying noise between FM stations. The muting circuitry may prevent the receiver from distinguishing a very weak signal from interstation noise. To tune in very weak stations, defeat the mute circuit by releasing the FM MUTE switch to the out position.

SPECIFICATIONS

FM TUNER SECTION

TUNING RANGE: 87.5 MHz to 108.5 MHz @ 300 Ω
QUIETING SENSITIVITY: 1.5 μ V for 30 db @ 72 Ω
0.5 μ V for 20 db @ 72 Ω
HARMONIC DISTORTION: 0.3% at 100% modulation.
FREQUENCY RESPONSE: 20-20,000 Hz fldb (after de-emphasis).
HUM AND NOISE LEVEL: 70 db below 100% modulation.
ALTERNATE CHANNEL SELECTIVITY: 60 db. LHFM
DETECTOR BANDWIDTH: 900 kHz.
CAPTURE RATIO: 1.9 db.
IMAGE REJECTION: 60 db.
I.F. REJECTION: 85 db.
CROSS MODULATION REJECTION: 80 db.
ANTENNA: 300 Ω balanced; 72 Ω unbalanced or built-in line.

AM TUNER SECTION

TUNING RANGE: 530 kHz to 1620 kHz.
LOOP SENSITIVITY: 2 μ V @ 6db S/N and 60% modulation.
ALTERNATE CHANNEL SELECTIVITY: (\pm 10 kHz) 40 db.
HARMONIC DISTORTION: Less than 1% @ 50% modulation

MISCELLANEOUS

AUDIO OUTPUT: Adjustable (rear panel), 0-1.2V
OPERATING CONTROLS: Selector (Power, AM, FM, FM Mute), Tuning.
POWER CONSUMPTION: 60W @ 120 vac, 60Hz
OVERALL DIMENSIONS: 14-1/2" W x 3-3/4" H x 12" D
RACK INTERIOR DIMENSIONS: 14" W x 3-1/4" H x 11" D
WEIGHT: 9-1/2 lbs.

INSTALLATION INSTRUCTIONS

UNPACKING

NOTE

This paragraph does not apply to tuners shipped as a part of a Bogen Centralized School Sound System console or rack.

If the Model TP160 AM/FM Tuner is not part of a Bogen Centralized School Sound System console or rack, carefully unpack the carton and inspect the unit for damage. If a unit shipped to you proves to be damaged, make an immediate claim with the shipping carrier. If the unit was picked up directly from a dealer or distributor, make any damage claim directly to the seller without delay.

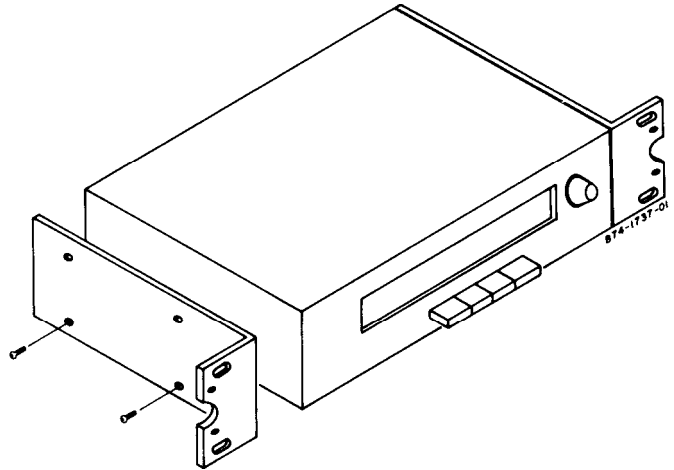

Figure 1 - Rack Mounting With Model RPK-31 Brackets

RACK INSTALLATION

NOTE

This paragraph applies only to tuners which will be installed in a 19" equipment rack.

The Model TP160 may be installed in a standard 19" equipment rack by using Model RPK31 rack mounting brackets. Remove the four screws securing the side of the cover. **Do not remove the cover.** Install the brackets as shown in figure 1, securing them to the tuner with the four screws supplied with the brackets. Each bracket has two elongated holes on three-inch centers for fastening to a standard 19" equipment rack.

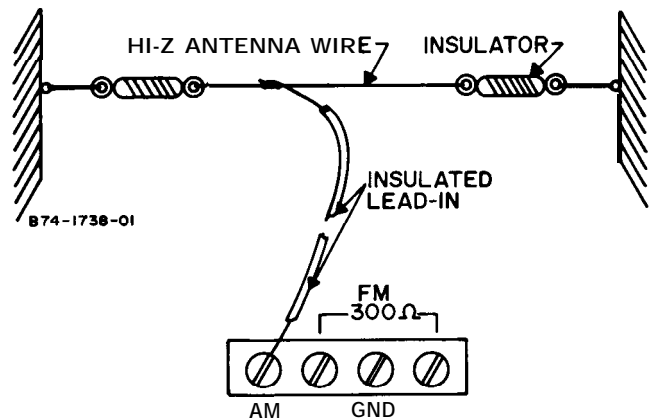

Figure 2 - Connecting AM Antenna

CONNECTING AM ANTENNA

An external antenna must be installed on any Model TP160 which will be used to receive AM broadcasts. Connect the antenna as shown in figure 2.

CONNECTING EXTERNAL FM ANTENNA

IMPORTANT

Always disconnect the FM Line Antenna when using an external FM antenna.

The Model TP160 has an internal FM Line Antenna which may be used for receiving FM broadcasts. For improved reception, particularly in weak signal areas or for tuners mounted in consoles or racks, installation of an outdoor FM or "T" antenna is necessary. If you are installing a standard 300-ohm antenna system, connect the twin-lead transmission line as shown in figure 3a. If conditions require use of a coaxial transmission line, such as RG-11/U or RG-59/U, connect the cable as shown in figure 3b. Coaxial cable must be used when the transmission line is run in conduit.

Connecting To External TV Antenna

For optimum performance, a separate FM antenna is recommended. If a TV antenna must be used for both FM and TV reception, install an FM signal splitter at the end of the transmission line, as shown in figure 4.

LEVEL CONTROL

Model TP160 AM/FM tuners shipped with Bogen Centralized School Sound System consoles or racks have the LEVEL control preset to the proper output for the booster amplifier. Tuners shipped separately have the LEVEL control set for maximum output, which is 1.2 volts.

To decrease the audio output from the tuner, turn the LEVEL control counterclockwise. To increase the audio output, turn the LEVEL control clockwise.

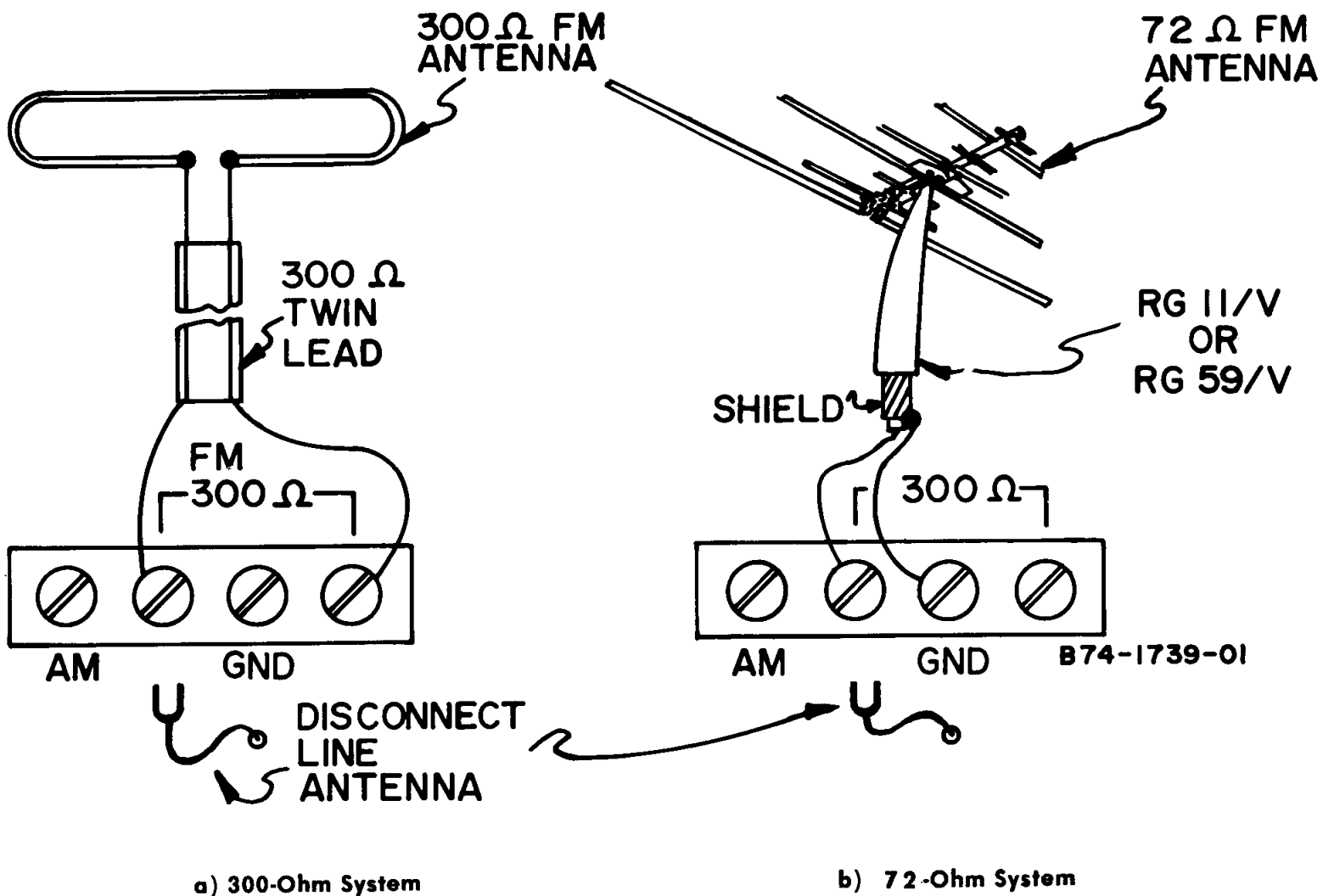

Figure 3 — Connecting External FM Antenna

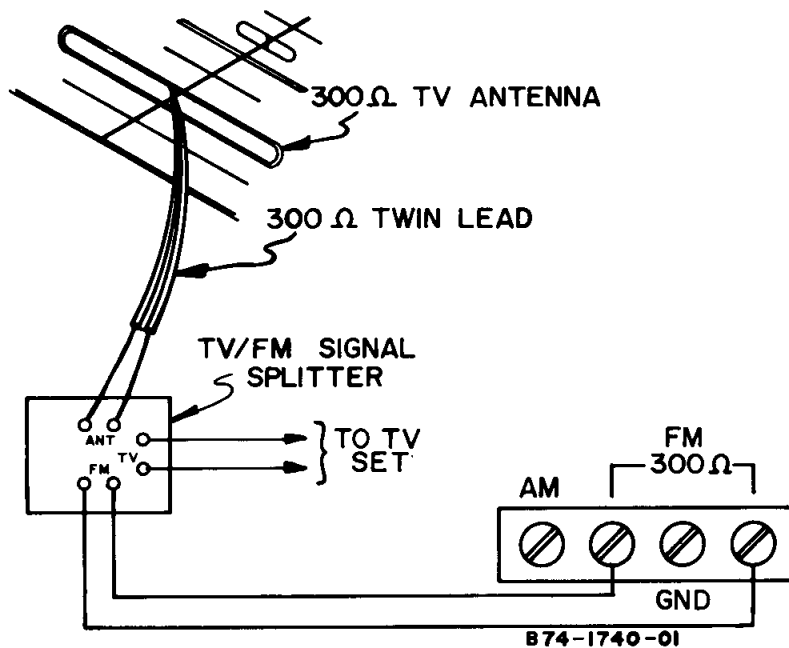

Figure 4 — Connecting TV Antenna

MAINTENANCE

WARNING

There are no user serviceable parts inside the unit and removal of the dust cover presents an electrical shock hazard. Interior servicing should be attempted only by a qualified technician.

BOGEN SERVICE

We are interested in your Bogen tuner for as long as you have it. If trouble ever develops with your unit, please do not hesitate to ask our advice or assistance. Write to Service Department, Bogen Division, Lear Siegler, Inc., P.O. Box 500, Paramus, New Jersey 07652.

When communicating with us, give the model number and serial number of your unit. Describe the difficulty encountered and the effects each operating control has upon the trouble symptoms. Include details on electrical connections to associated equipment, and list such equipment. When we receive this information, we will send you service information if the trouble appears to be simple. If the trouble requires servicing, we will send you the name and address of the nearest Bogen authorized service agency to which you can send your unit for repairs.

When shipping your unit, pack it carefully using the original shipping carton, or a similar container and filler material, to prevent damage in transit. Send the unit, fully insured and prepaid, via railway express or United Parcel. ***Do not ship via parcel post unless so instructed.***

DIAL CORD RESTRINGING. Refer to figure 5 and proceed

as follows:

- Remove front panel by pulling off TUNING knob and removing two Phillips-head screws.
- Connect dial cord at drum hook marked START in diagram.
- String dial around nylon pulleys and tuning shaft to drum hook marked FINISH in diagram. Make certain cord winds around tuning shaft from rear toward front, as shown.
- Attach end of cord with tension spring, making certain that spring applies enough pressure to prevent cord from slipping.
- Tune in a known station and attach dial pointer at proper position. Before securing pointer, twist cord as shown in diagram so cord will exert a slight pressure toward panel bracket and away from dial glass.

REPLACING DIAL LAMP. Remove front panel as described in step a), above, and replace lamp with 6.3V No. 12 bulb (Bogen Part 94-0175-01).

REPLACEMENT PARTS

Most components used in the Model TP160 are available through all reputable parts jobbers. The parts listed here are available from Bogen distributors, service agencies or directly from the factory.

When ordering parts from Bogen, specify the part number and description, as listed below. Also give the Model TP160 and the Series designation, which is a letter followed by numbers stamped or screened on rear of the chassis. When ordering a part for the PC Board, also give the PC Board component number, which is 45-9764-01.

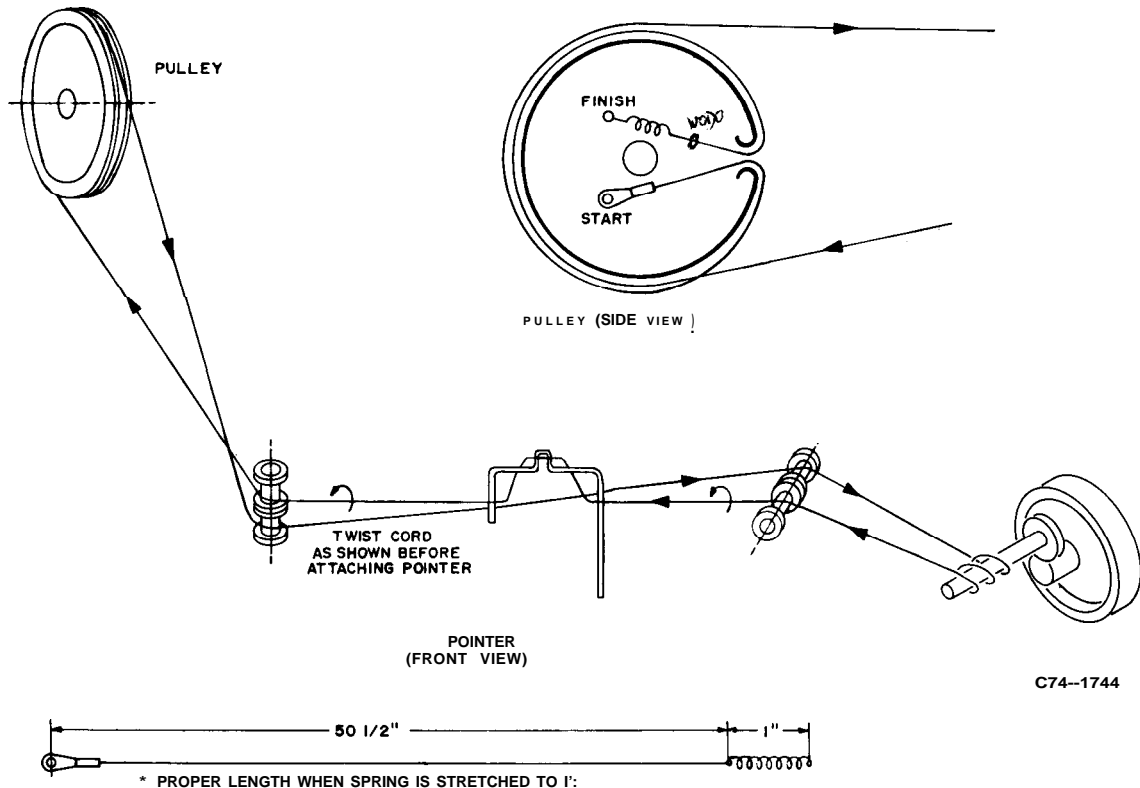

Figure 5 - Dial Stringing Diagram

| Ref. No. | Part No. | Description | Ref. No. | Part No. | Description |
|-----------|------------|--|---------------------------------|------------|--|
| AI | 45-9764-01 | RF, IF Component Board Assy, Complete | T3 | 96-5153-01 | Transformer, 2nd AM IF |
| c3 | 79-005-044 | Capacitor, Electrolytic, 2 μ F, 25 V | T4 | 965157-01 | Transformer, FM IF |
| C6 | 79-209-001 | Capacitor, 5pF, 500 V | T5 | 96-5151-01 | Transformer, FM Discriminator |
| c7 | 79-008-057 | Capacitor, 50 μ F, 50 V | Chassis Electrical Parts | | |
| C13 | 78-221-121 | Capacitor, 470pF | C10I-C104 | 78-201-115 | Capacitor, 150pF, 500 V |
| C14 | 78-221-116 | Capacitor, 180pF | C107 | 78-200-100 | Capacitor, 15pF, 1400 V |
| c25 | 79-005-049 | Capacitor, 25 μ F, 35 V | C108 | 79-005-062 | Capacitor, Electrolytic, 500 μ F, 50V |
| C26 | 78-221-113 | Capacitor, 100pF | C109 | 79-005-054 | Capacitor, Electrolytic, 700 μ F, 35 V |
| C30 | 78-250-005 | Capacitor, .06 μ F, 50 V | C110 | 79-005-039 | Capacitor, Electrolytic, 1000 μ F, 15V |
| c31 | 78-201-099 | Capacitor, 6.8pF, 5% | CRI01, 102 | 96-5109-01 | Diode, 100mA, 150 PIV |
| C35,36 | | (Same as C26) | CR103 | 96-5248-04 | Diode, Zener, 12 V, 1 W |
| c37 | | (Same as C13) | 1101,102 | 94-0175-01 | Lamp, Dial |
| C40 | 79-005-049 | Capacitor, Electrolytic, 25 μ F, 25V | LI01, 102 | 95-5148-01 | Coil, RF Choke, 3.9 μ H |
| c41 | 79-005-055 | Capacitor, Electrolytic, 4 μ F, 50 V | L103 | 95-5159-01 | Coil, AM Antenna |
| C46 | | (Same as C3) | L104 | 95-5015-01 | Coil, RF Choke, 1 μ H |
| CR1,4 | 96-5093-02 | Diode, 1N541 | M101 | 94-1309-01 | Meter, Tuning |
| CR2,3 | 96-5093-01 | Diode, 1N542, Matched Pair | R107 | 77-001-467 | Control, LEVEL |
| FL-1, 2 | 78-959-001 | Ceramic Filter, FM IF (Specify Color Code) | SW102-104 | 81-004-053 | Assembly, Pushbutton Switch |
| FL-3 | 95-5158-01 | Mechanical Filter, 455 KHz | SW101 | 81-003-049 | Switch, SPST, 3 A, with Cover |
| IC-1 | 96-5238-02 | Integrated Circuit, 1st FM IF | T101 | 83-750-000 | Transformer, Power |
| IC-2 | 96523801 | Integrated Circuit, 2nd FM IF | Mechanical Parts | | |
| L1 | 95-5146-01 | Coil, Choke, 56 μ H | - | 12-4503-01 | Dial Cord |
| MPI | 94-1277-01 | FM Tuner Assembly | - | 12-4165-01 | Dial Glass |
| Q1, 2 | 96-5221-01 | Transistor, 2N5127 | - | 02-9003-08 | Dial Spring |
| Q3,4 | 96-5235-01 | Transistor, 2N5126 | - | 22-5234-01 | Cover |
| Q5 | 96-5237-01 | Transistor, BC147B | - | 14-9064-01 | Foot, Cover |
| Q6,7 | 96-5213-01 | Transistor, 2N5089 | - | 03-0629-02 | Knob, Tuning |
| R90 | 77-001-691 | Control, Mute Adj., 47 K | | | |
| T1 | 95-5156-01 | Transformer, AM Oscillator | | | |
| T2 | 95-5152-01 | Transformer, 1st AM IF | | | |

ALIGNMENT

The following instruments (or equivalent) are required for a complete alignment of the receiver.

DC VTVM, RCA WV98-C

AC VTVM, HP 400D

AM Signal Generator, Measurements Corp 65-B

FM Sweep Generator, Measurements Corp 88 or Boonton Radio Corp 202H

AM Alignment

To completely align the AM section, start with the last AM IF transformer and work back toward the antenna. In order to limit the effect of the AGC circuit, continually reduce the generator signal level to the minimum required for an output indication. Make the adjustments listed in Table I. See figure 6 for location of alignment adjustments.

FM Alignment

To align the FM section, follow the procedure given in Table II. See figure 7 for location of adjustments.

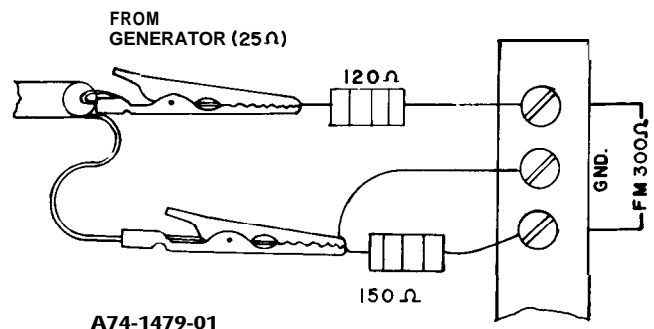

A74-1479-01

Figure 6 - Dummy Antenna for FM Alignment

TABLE I – AM ALIGNMENT CHART (See Figure 7)

NOTE: Set Selector Switch to AM

| Step | Band & Dial Setting | Generator Frequency | Signal Input | Indicator and Connection | Adjustment and Indication |
|------|---|--|--|--|--|
| 1 | Indicator at Extreme left end of dial | 455 kHz 30%, AM Mod at 400 Hz. Generator output level 5 μ V, maximum | Through .05 MFD capacitor to TP-22, terminal 22 of A1. | DC VTVM at TP-, 2, terminal 2 of A1. | Adjust T2 and T3 for maximum indication on meter. As a gain check, input should be less than 4 μ V for an. output 0.5 vdc above noise. |
| 2 | AM at 600 kHz | 600 kHz, 30% AM Mod at 400 Hz. Generator output level 1 mV, maximum. | AM EXTERNAL ANT. and GND. | Oscilloscope and dc VTM at TP-2, terminal 2 of A1. | Adjust T1 and Ant Coil L103 for maximum indication on meter. Keep dc output level below 1 volt by reducing input as peak is approached. |
| 3 | AM at 1400 kHz | 1400 kHz, 30% AM Mod at 400 Hz. Generator o output level 500 μ V, maximum. | Same as Step 2, above. | Same as Step 2, above. | Adjust (first) AM OSC TRIM, (then) AM ANT TRIM for maximum indication on meter. Keep dc output level below 1 volt by reducing input as peak is approached. |
| 4 | Repeat steps 2 and 3, above until all outputs are peaked at the proper frequencies. As a gain check, 600 kHz input should be less than 30 μ V for output of 0.5 vdc above noise, and 1400 kHz input should be less than 35 μ V for output of 0.5 vdc above noise. | | | | |

TABLE II – FM ALIGNMENT CHART (See Figure 7)

Set FM MUTE Switch to OUT (button out), and Selector Switch to FM (button in).

| Step | Dial Setting | Generator Frequency | Signal Input Point | Indicator & Connection | Adjustment and indication |
|---|---|---|---|--|--|
| 1 | Check color code (paint dot) on ceramic filters FL1 and FL2 (figure 2) to determine IF center frequency. Frequency for each color is: Green (10.60), Black (10.65), Blue (10.67), Red (10.70). Orange (10.73), White (10.75), Yellow (10.80). Both filters in any one receiver must have same colored dots. | | | | |
| 2 | FM at 98 MHz | 98 MHz \pm 300kHz sweep deviation at 400 Hz modulation. Generator output level approx. 20 μ V. | FM 300 ohm antenna terminals through dummy antenna (see figure 6) | Oscilloscope at TP-6, terminal 6 of A1. | Adjust T4 and FM IF XFMR (in tuner) for max gain with good symmetry. Adjust T5 for optimum "S" curve. |
| 3 | FM at 104 MHz | 104 M H z \pm 75 kHz sweep deviation at 400 Hz modulation. Generator output level approx. 10 μ V. | Same as Step 2, above | Tuning Meter | Check tracking. If necessary, adjust FM OSC TRIM, FM RF TRIM and FM ANT TRIM for max gain. |
| 4 | FM at 90 MHz | 90 MHz μ 75kHz sweep deviation at 400 Hz modulation Generator output level approx. 10 μ V. | Same as Step 2, above. | Tuning Meter | Check tracking. If necessary, adjust FM OSC COIL, FM RF COIL and FM ANT COIL for max gain. FM OSC COIL is adjusted by carefully compressing turns closer together with an insulated instrument. |
| NOTE: Repeat steps 3 and 4 as required to obtain satisfactory tracking at both frequencies. | | | | | |
| FM MUTING CHECK | | | | | |
| 5 | FM at 98 MHz | 98 MHz \pm 75kHz sweep deviation at 400 Hz. Generator output level 20 μ V. | Same as Step 2, above | ac VTVM and scope at TP-8, terminal 8 of A1. | Record ac output level on VTVM |
| 6 | Same as Step 5, above. | Same as Step 5, above. | Same as Step 2, above. | Same as Step 5, above. | Depress FM MUTE switch. Reading at TP-8 should drop about 3 db. If required, adjust MUTE ADJ (R90) for proper reading. |

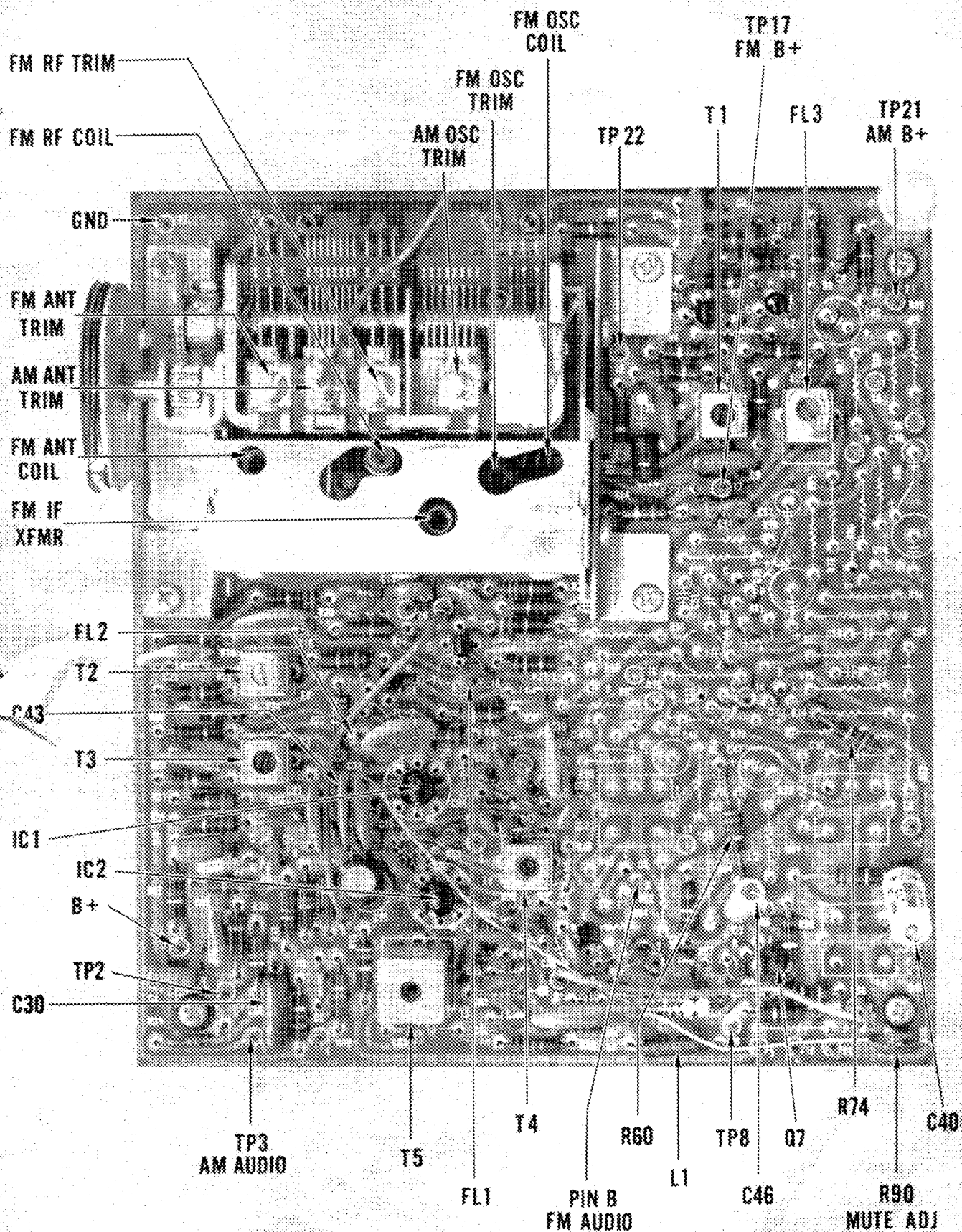

Figure 7 — Alignment Adjustments and Test Points

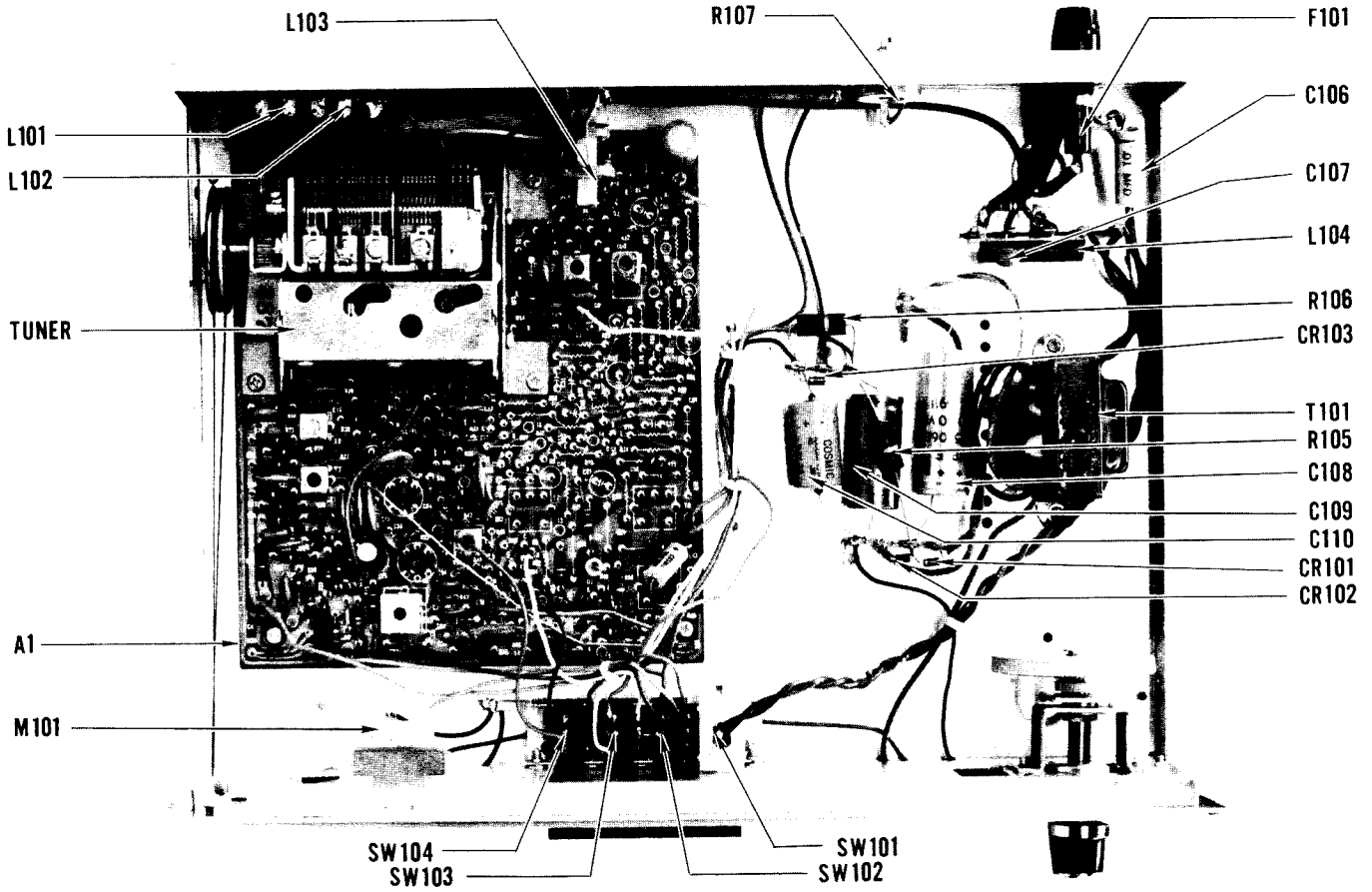

Figure 8 — Model TP160, Parts Location

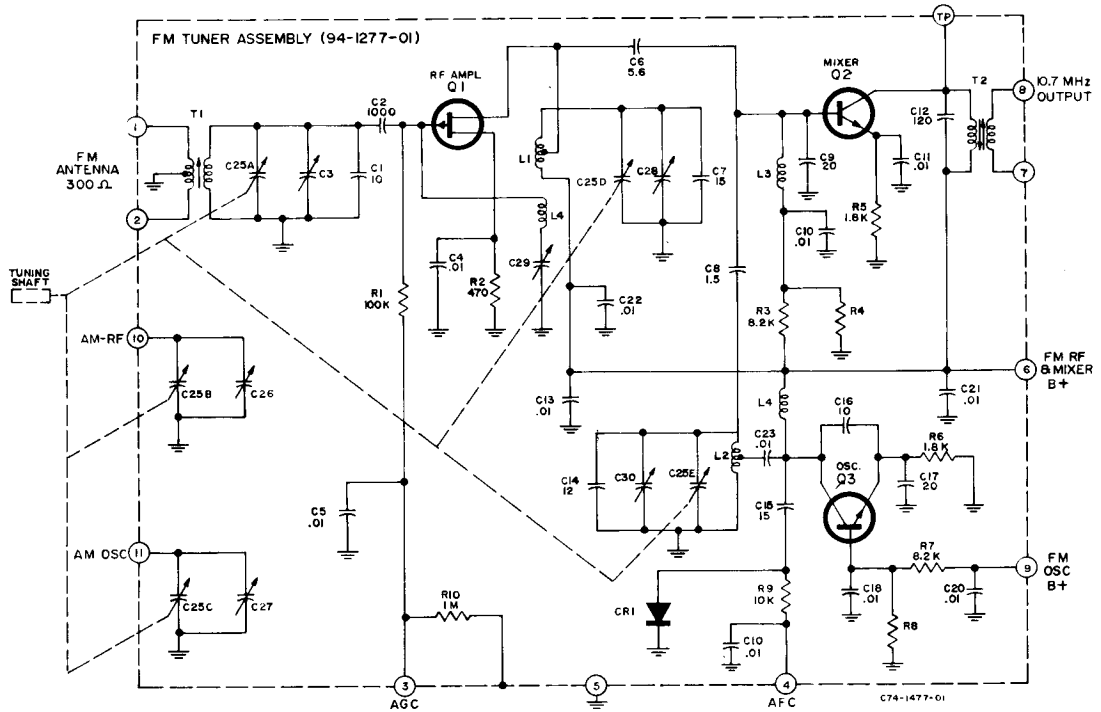
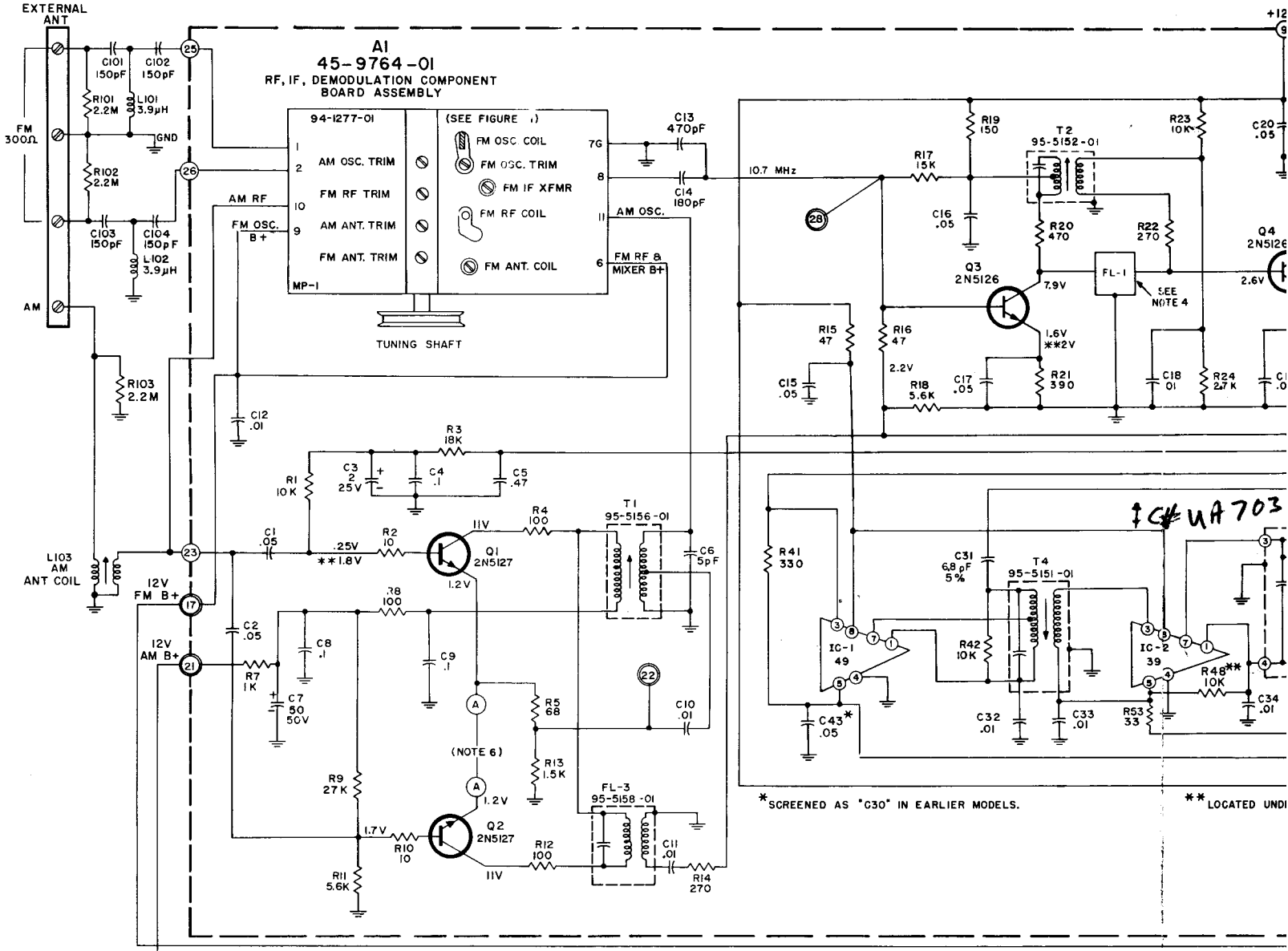
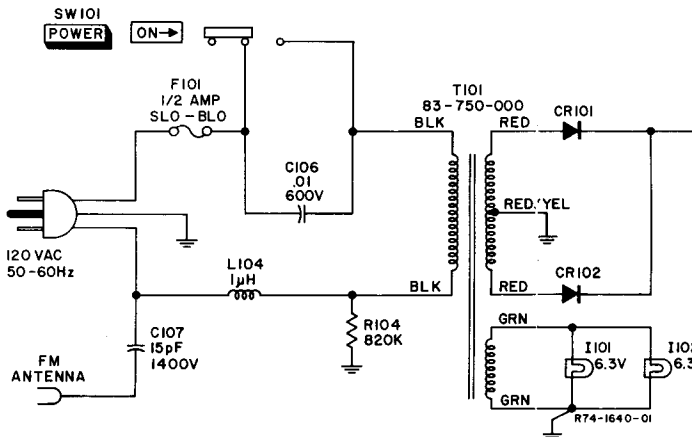
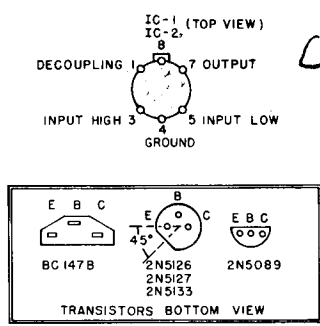

Figure 9 — FM Tuner Sub-Assembly, Schematic Diagram



- NOTES**
- UNLESS OTHERWISE SPECIFIED
- 1.) ALL RESISTORS ARE 1/2W, ±10%. ALL CAPACITORS ARE IN MFD.
 - 2.) ALL VOLTAGES ARE +DC REFERRED TO CHASSIS GROUND WITH NO SIGNAL.
* INDICATES VOLTAGES WHEN SET IS RECEIVING FM BROADCAST.
** INDICATES VOLTAGES WHEN SET IS RECEIVING AM BROADCAST.
 - 3.) ALL Ⓞ REPRESENT TEST POINTS.
 - 4.) CERAMIC FILTER, FREQUENCY (MHz) AS PER THE FOLLOWING COLOR CODE:
BLACK (10.64), RED (10.70), ORANGE (10.73), YELLOW (10.80), GREEN (10.60), BLUE (10.67), WHITE (10.75).
 - 5.) CR2 AND CR3 ARE A MATCHED PAIR.
 - 6.) JUMPER WIRES ON BOARD.



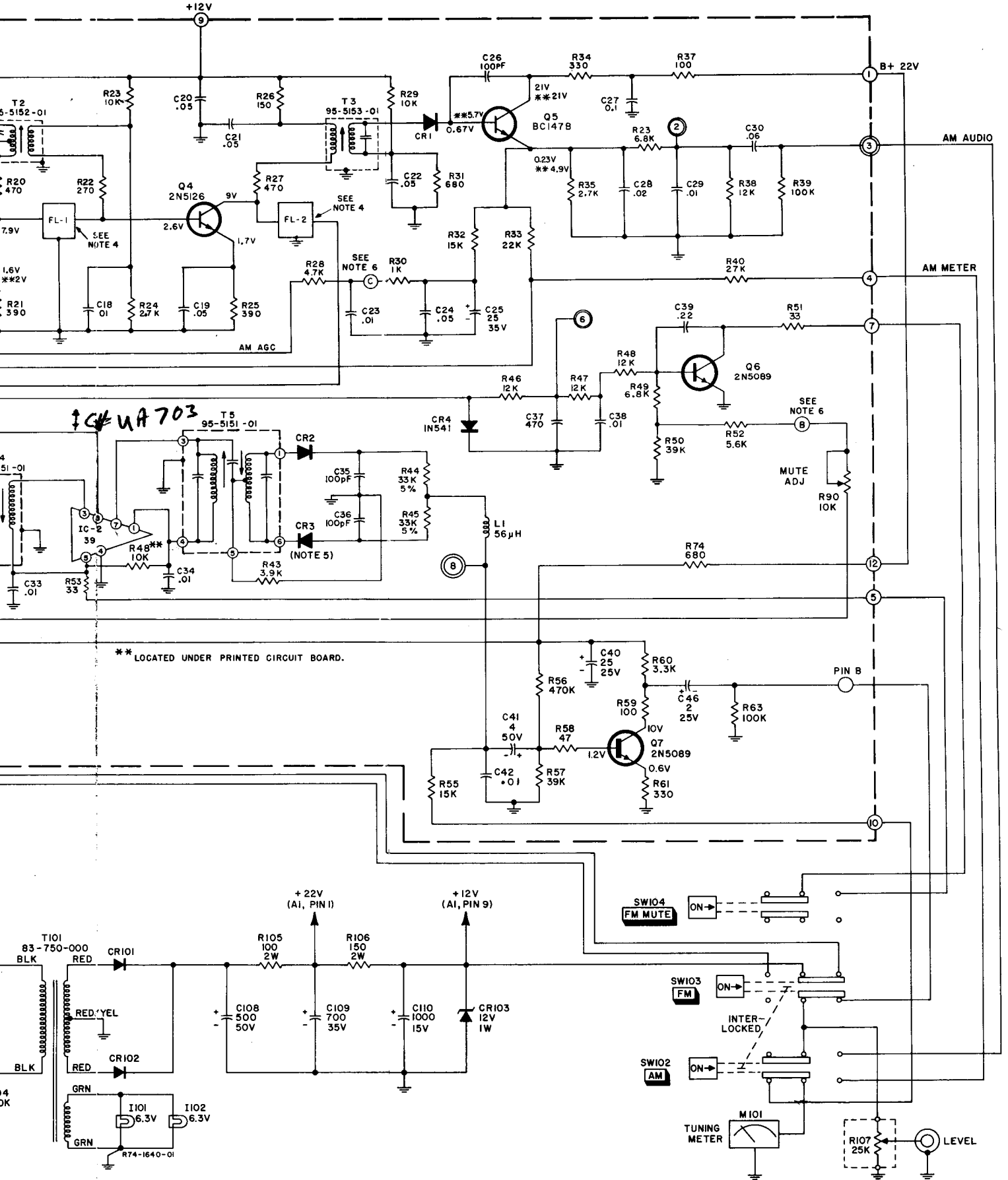

Figure 10 — Model TP160 AM/FM Tuner, Schematic Diagram