

# BOGEN<sup>®</sup>

COMMUNICATIONS, INC.

## MIXER/POWER AMPLIFIERS

DMA-20, DMA-40, DMA-80, DMA-160

## INSTALLATION & OPERATION INSTRUCTIONS

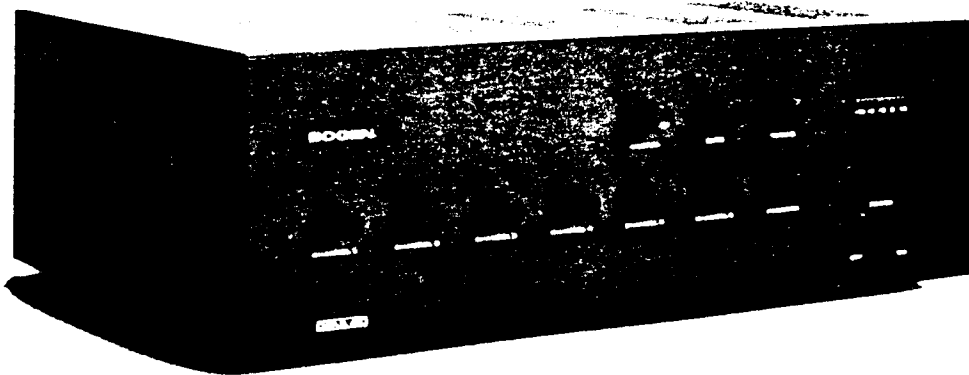

The Bogen DMA-Series mixer/power amplifiers combine module input with high-performance MOSFET circuitry to permit a custom-designed approach to sound reinforcement and paging using a single amplifier. The DMA-20 is a five channel (4 module/1 program) unit, rated at 20 watts. The DMA-40, DMA-80, and DMA-160 have seven channels (6 module/1 program) and are rated at 40, 80, and 160 watts, respectively.

Any of the Bogen plug-in modules may be installed in the rear panel ports to define each channel's function. Inputs are mixed on an active bus, allowing interaction for a three-level priority scheme. Modules set to priority level 1 can receive (are muted by) priority signals from modules set to priority levels 2 and 3. Modules set to priority level 2 send priority signals to (and mute) modules set to priority level 1, and receive priority signals from modules set to priority level 3. (Modules set to priority level 1 or 2 are also muted when the rear panel MUTE terminals are shorted through a contact closure.) Modules set to priority level 3 send priority signals to (and mute) the program input and modules set to priority level 1 or 2.

The program input has its own level control and is designed primarily for background music applications. The program input also has a (screwdriver-adjusted) variable mute feature, activated by customer-supplied contact closure (or priority signal from an input module).

An individual level control is provided for each module channel. Full-range bass and treble controls and master level control are also provided. Output level indication is provided by an LED meter. A low-cut filter, tone control defeat, and preamp link switch are located in the module cage to prevent tampering after installation.

The DMA mixing bus may be strapped to other DMA amplifiers through bridging jacks on each unit. Preamp Out/Power Amp In jacks permit the installation of signal processing equipment. Direct and transformer-coupled outputs are provided to match 4- and 8-ohm speaker systems, and 25V and 70V distributed systems. The DMA-80 includes a 25 volt center-tapped output for applications requiring a true balanced 25V line.

# TECHNICAL SPECIFICATIONS

<b>Output Power Rating</b> DMA-20: DMA-40: DMA-80: DMA-160:	20 Watts @ 4-ohms, 8-ohms, 25V and 70V 40 Watts @ 4-ohms, 8-ohms, 25V and 70V 80 Watts @ 4-ohms, 8-ohms, 25VCT, 25V and 70V 160 Watts @ 4-ohms, 8-ohms, 25V and 70V
<b>Frequency Response</b>	20Hz-20kHz, +0,-2dB (See Performance Curves)
<b>Distortion</b> Direct: Transformer:	0.3% (max.), 20Hz-20kHz, 1 watt to rated output power 0.3% (max.), 65Hz-20kHz, 1 watt to rated output power
<b>Signal-to-Noise Ratio</b>	75dB or better
<b>Input Sensitivity/Impedance</b> Module Channels: Program Input: Bridging I/O: Power Amp Input:	100mV/10-kilohms 100mV/10-kilohms 100mV/3-kilohms 1V/10-kilohms
<b>Tone Control</b> Bass: Treble:	± 10dB @ 100Hz ± 10dB @ 10kHz
<b>Preamp Out</b>	1V @ 600-ohms
<b>Variable Mute Range</b>	60dB (min.)
<b>Lo-Cut Filter</b>	-3dB @ 65Hz, 6dB/octave
<b>Dimensions</b> DMA-20: DMA-40, -80, -160:	3-1/2"H x 16-1/2"W x 9-1/8"D 5-1/2"H x 16-1/2"W x 11-3/8"D

## PERFORMANCE CURVES

(TYPICAL FOR ALL MODELS)

DIRECT  
OUTPUT 

TRANSFORMER OUTPUT  
WITH 6dB/OCTAVE  
LO-CUT FILTER IN CIRCUIT 

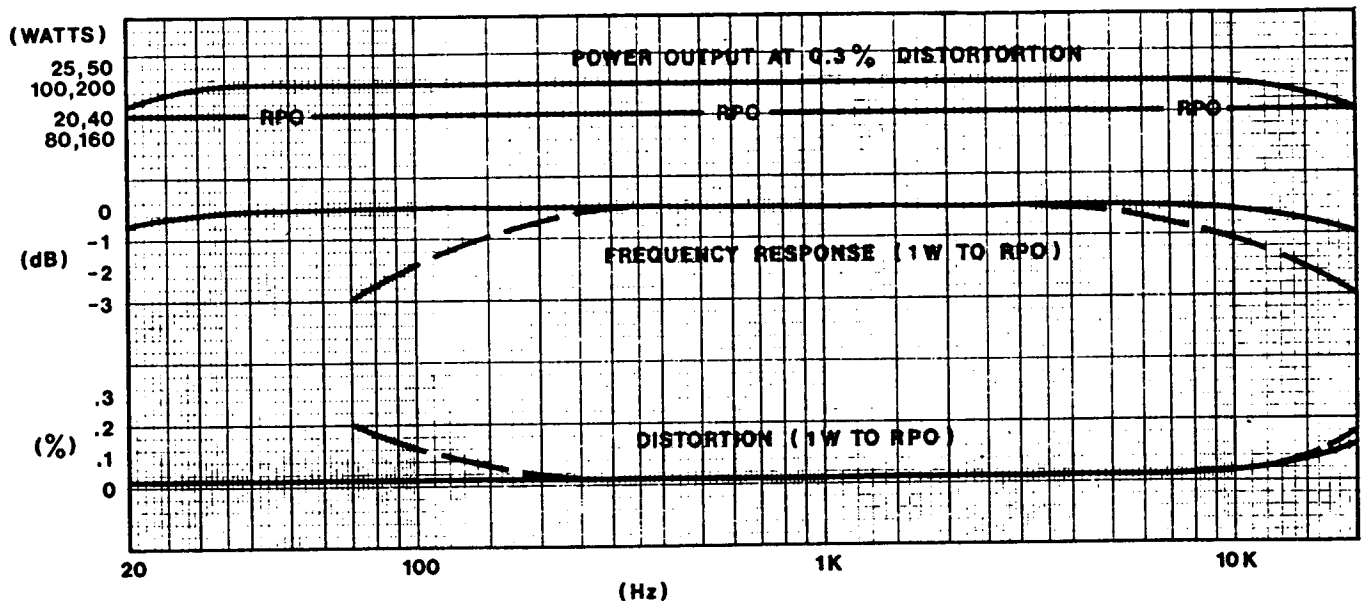

## INPUT MODULES

### SOUND REINFORCEMENT MODULES MM-F and MM-S

Low-impedance, transformer-balanced microphone preamplifier module. Includes high- and low-frequency cut filters and gain control (25dB range). Jumper-selected phantom power. The MM-F has a female XLR-type connector. The MM-S has screw terminal connectors.

### MICROPHONE PAGING MODULE MP-S

Signal-activated low-impedance, transformer-balanced microphone preamplifier module. Includes high- and low-frequency cut filters and gain control (25dB range). Automatic level control (ALC) keeps the output level constant (may be defeated). May be assigned to any of three levels of priority. Jumper-selected phantom power. Screw terminal connectors.

### TELEPHONE PAGING MODULE TP-S

Signal-activated telephone paging module. Provides a 600-ohm balanced input with -24dBm sensitivity for matching to telephone page lines. Includes high- and low-frequency cut filters and gain control (25dB range). Automatic level control (ALC) keeps the output level constant; may be defeated allowing the TP-S to be used as an AUX input module. May be assigned to any of three levels of priority. Screw terminal connectors.

### AUXILIARY INPUT MODULE BL-S

Transformer-balanced auxiliary input module. A printed circuit board jumper selects either 600-ohm input or 10-kilohm input, suitable for line-bridging or line-matching. Screw terminal connectors.

### LINE OUTPUT MODULE LO-S

Line output module provides 600-ohm transformer-balanced +4dBm output from the mixing bus. Provides 0.5-watt output at 8-ohms with the transformer bypassed for music-on-hold applications. Parallel RCA jacks permit one tuner to be used for background music and MOH. A 20dB pad matches the music source output and module input levels.

### STONE SIGNAL GENERATION MODULE TG-S

The module generates four distinct tones: 3-stroke chime, steady tone, alarm, and tone burst. 90mV output. May be assigned to any of three levels of priority. Requires customer-supplied contact closures. Screw terminal connectors.

### REMOTE VOLUME CONTROL OR COMPRESSION MODULE VC-C

Dual-function compressor/remote volume control module, function selected with a printed circuit board jumper. The compressor limits the power amplifier input signal to 1 volt to prevent overdrive. The DC-operated full range volume control allows any output setting up to the maximum preset on the amplifier's front panel master level control.

### FM RECEPTION MODULE FM-T

FM tuner module designed as a preset background music source with screwdriver-adjusted tuning. The module output is assigned, via a printed circuit board jumper, to either the mixing bus of the amplifier or to the module's RCA connector. Monaural operation. Screw terminals are provided for antenna connection.

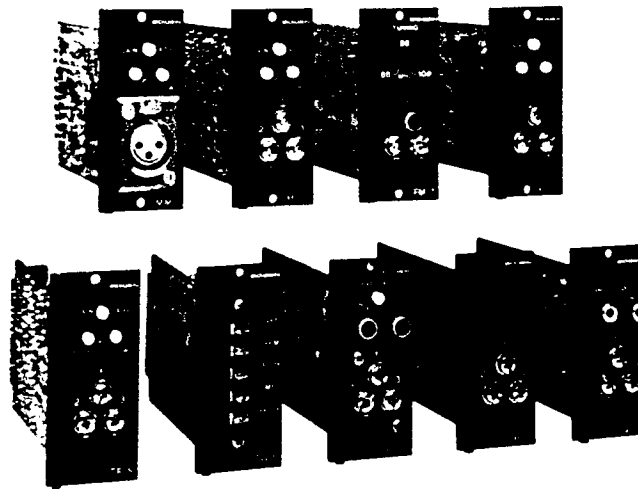

Application-Specific Input Modules Define the Function of Each Channel

## PHYSICAL FEATURES

### FRONT PANEL CONTROLS AND INDICATORS

<b>POWER</b>	Rocker-type switch illuminates when power has been applied.	<b>PROGRAM</b>	Level control for the fixed program input.
<b>LEVEL</b>	Bar-type LED meter provides a graphic display of the output level. Illuminates red when levels above 0dB are reached, to indicate possible signal clipping.	<b>MASTER</b>	Master output level control.
<b>CHANNEL 1-6</b>	Individual level controls for module input channels 1 through 6 (1 - 4 on DMA-20).	<b>BASS</b>	Provides $\pm 10$ dB attenuation at 100Hz (with tone control switch IN).
		<b>TREBLE</b>	Provides $\pm 10$ dB attenuation at 10kHz (with tone control switch IN).

### REAR PANEL CONTROLS AND CONNECTORS

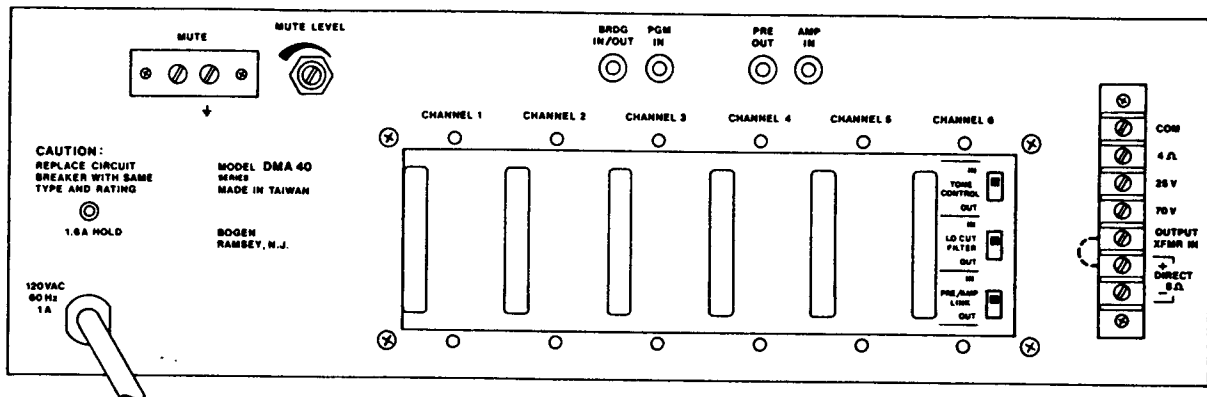

<b>LINE CORD</b>	Three-wire line cord supplies power to the amplifier.	<b>PREAMP OUT</b>	Provides output of preamp for connection to signal processing modules. Used with PRE/AMP LINK switch OUT.
<b>AC BREAKER</b>	Press-to-reset AC circuit breaker protects against excessive current flow.	<b>AMP IN</b>	Input connector for power amplifier when PRE/AMP LINK switch is OUT.
<b>INPUT PORTS</b>	Card edge connectors accept plug-in modules.	<b>OUTPUT</b>	Screw-terminal strip for connection to direct and transformer-coupled outputs.
<b>PGM IN</b>	Fixed program input for high level source (e.g., tape player or phono).	<b>LOW CUT</b>	<i>IN</i> : Provides -3dB attenuation @ 65Hz 6dB/octave. <i>OUT</i> : Disables low-cut filter action.
<b>MUTE</b>	Terminals provided activate mute bus. Requires a customer-supplied contact closure. The Program input (PGM IN) and any module set for priority level 1 or 2 will be muted by contact closure.	<b>PRE/AMP LINK</b>	<i>IN</i> : Connection between preamplifier and power amplifier. <i>OUT</i> : Provides disconnect between preamplifier and power amplifier.
<b>MUTE LEVEL</b>	Screwdriver-adjustable mute level control for PGM IN input. 60dB range.	<b>TONE CONTROL</b>	<i>IN</i> : Enables front panel bass and treble controls. <i>OUT</i> : Bypasses tone controls for flat response.
<b>BRDG IN/OUT</b>	Allows strapping of mixing busses from another DMA amplifier. Output level is independent of master control; may be used as an output for tape recorder.		

# INSTALLATION AND OPERATION

## INSTALLATION

### UNPACKING

The amplifier was carefully checked before leaving the factory. Inspect the shipping container and the unit closely for evidence of improper handling. If the unit has been damaged, place an immediate claim with the dealer/distributor from whom the unit was purchased. If the unit was shipped directly to you, notify the transportation carrier without delay and file a claim.

### RACK MOUNTED INSTALLATION

The amplifiers are designed for installation in standard equipment racks. Use Model DRK-2 Rack Panel Kit for DMA-20 and Model DRK-3 for DMA-40, DMA-80 and DMA-160.

### MODULE INSTALLATION

#### Caution

*Be sure that the front-panel-mounted POWER switch is in the OFF position before installing or removing modules.*

Modules are easily inserted in any available port of the module cage. Align the top and bottom edges of the module circuit board in the slots of the port, and slide the module into the cage to engage the card edge connectors. Secure the module to the amplifier with two screws.

### PRIORITY

Set the priority level on modules so equipped to the desired level before installing them in the amplifier. The level is set by repositioning printed circuit board-mounted shunts. The screening on the module printed circuit board shows which pins to connect for the desired priority level.

**PRIORITY LEVEL 1** — The module receives, and is muted by, priority signals from any module set to priority level 2 or 3. A module set to priority level 1 is also muted when the rear panel MUTE terminals are shorted through a contact closure.

**PRIORITY LEVEL 2** — The module sends priority signals to mute any module set to priority level 1, and receives priority signals from any module set to priority level 3. A module set to priority level 2 is also muted when the rear panel MUTE terminals are shorted through a contact closure.

**PRIORITY LEVEL 3** — The module set to priority level 3 sends priority signals to mute modules set to priority level 1 or 2 and the program (PGM) input.

### OUTPUT TERMINAL STRIP

The DMA-Series provides an unbalanced direct output at 4-ohms (DMA-80, DMA-160) and 8-ohms (DMA-20, DMA-40). 25V and 70V transformer-coupled taps are provided for distributed systems on all models. The DMA-80 includes a 25V center-tapped output.

When using transformer-coupled outputs, be sure that the link on the output terminal strip connects the OUTPUT XFMR IN terminal to the DIRECT+ terminal. Remove the link when using the direct output.

A low cut switch is used to reduce unnecessary low frequency when using transformer-coupled outputs. Set this switch to IN when using transformer-coupled outputs, and OUT when using the direct output.

Operation of the variable-mute feature (0 to -60dB range) requires a customer-supplied contact closure across the MUTE terminals. This contact closure will mute the program input (PGM) and any module set to priority level 1 or 2.

## OPERATION

#### Caution

*Ensure that all input and output connections have been properly made before applying power to the unit and that all plug-in modules are seated securely in the edge connectors.*

### POWER

The front-panel-mounted rocker switch applies power to the amplifier. An integral pilot lamp illuminates when power has been applied.

### LEVEL CONTROLS

Set gain controls and filter controls on modules so equipped to mid-rotation. Set the amplifier front-panel channel level controls to their full counterclockwise position. Control the level of each channel with clockwise rotation of these controls. The overall output level is adjusted with the MASTER control. The output level LED meter will begin to illuminate red as the amplifier reaches full output power. A constantly lit red LED indicates possible output signal clipping.

### TONE CONTROL

When the tone control switch in the module cage is in the OUT position, the front panel tone controls are disabled and the tone response will be flat. To enable the front panel tone controls, set the tone control switch to the IN position. Bass and treble tone controls provide  $\pm 10$ dB cut/boost at 100Hz and 10kHz, respectively.

### AC CIRCUIT BREAKER

If the AC circuit breaker trips, the power switch pilot lamp will go out and there will be no output. Set the AC power switch to OFF and depress the red button on the circuit breaker to reset it. Return the AC power switch to ON. If the breaker trips again, have the trouble investigated by a qualified technician.

### THERMAL BREAKER

The thermal breaker will open when the temperature at the output transistor heat sink reaches 105°C (221°F) on all models. If the breaker opens, there will be no output but the power switch pilot lamp will remain illuminated. Wait approximately two minutes for the breaker to reset. If the breaker resets and then opens again, investigate the cause of the temperature overload. This may be due to improper connections at the output terminals or excessive environmental heat with inadequate ventilation.

# BOGEN SERVICE

## BOGEN SERVICE

We are interested in the maintenance of your Bogen equipment. If trouble ever develops, do not hesitate to ask our advice or assistance. Information can be obtained by writing to Service Department, Bogen Communications Inc., P.O. Box 575, Ramsey, N.J. 07446.

When communicating with us, give the model and series designation (stamped on the rear panel) of your unit. Describe the difficulty and include details on the electrical connection to

associated equipment. We will send you service information if the trouble appears simple. If the amplifier requires servicing, we will send the name and address of the nearest Bogen Service Agency to which you can send the unit for repairs.

When shipping the unit, remove all modules. Send the unit, insured and prepaid, via any responsible carrier. The unit will be promptly repaired and returned to you collect (freight prepaid while in warranty).

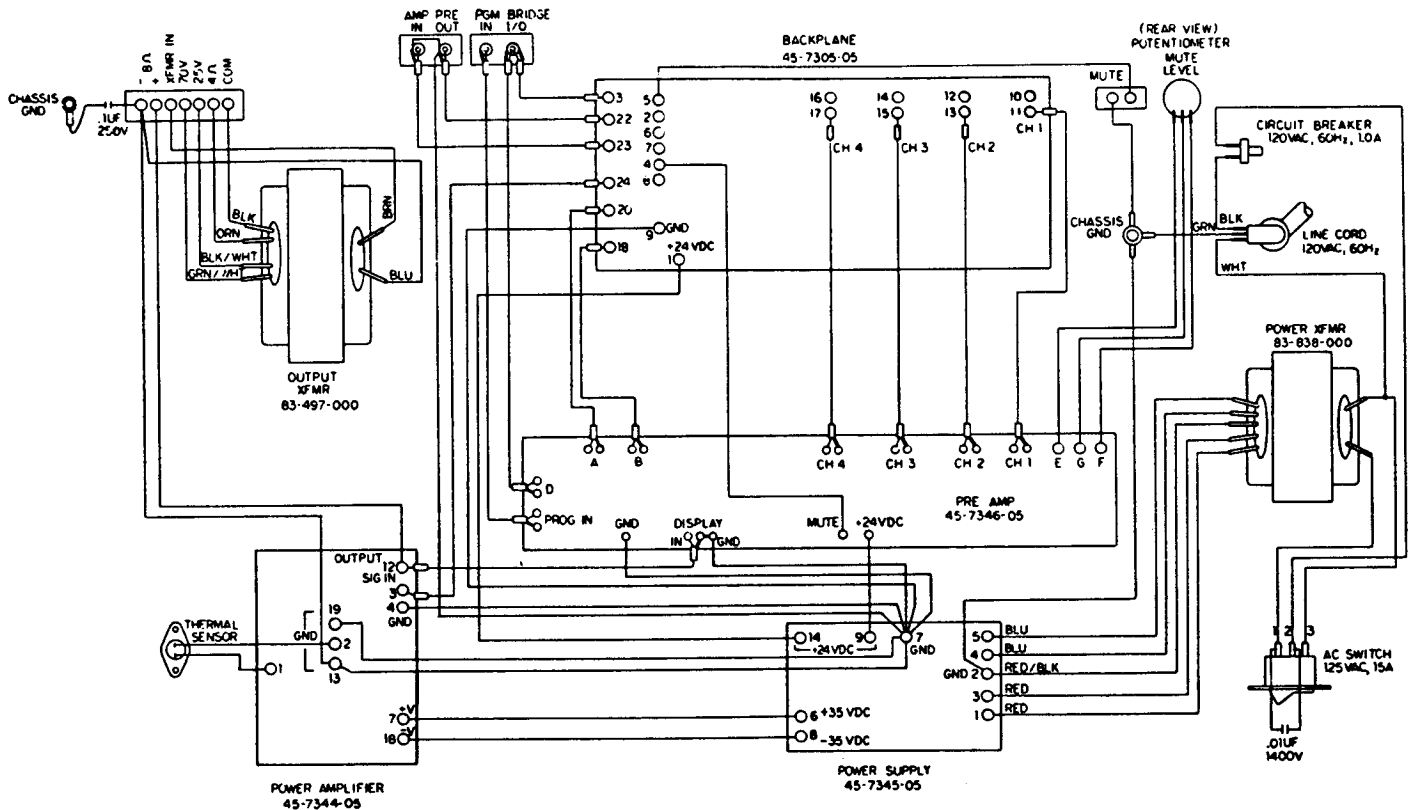

DMA-20 - Wiring Diagram

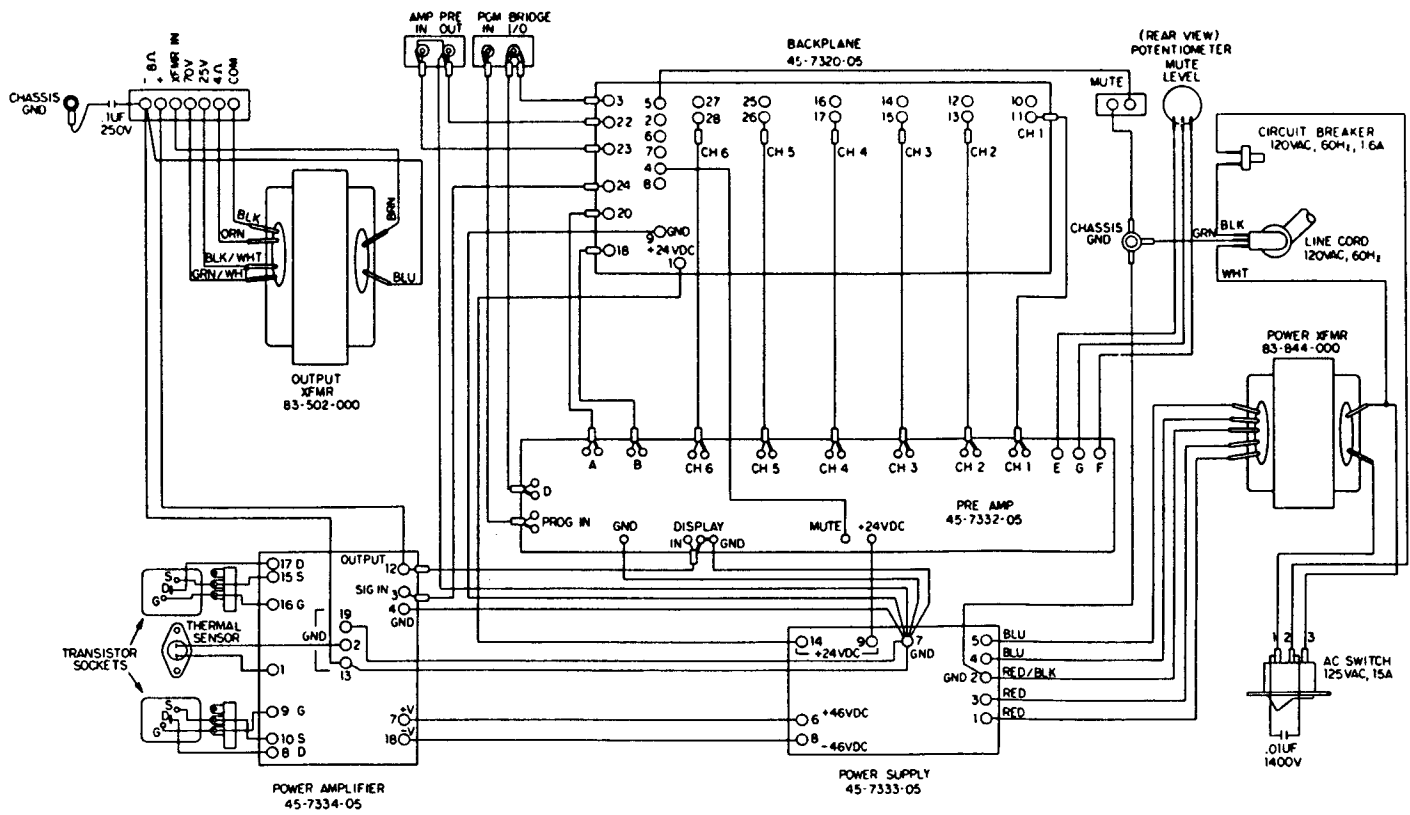

DMA-40 – Wiring Diagram

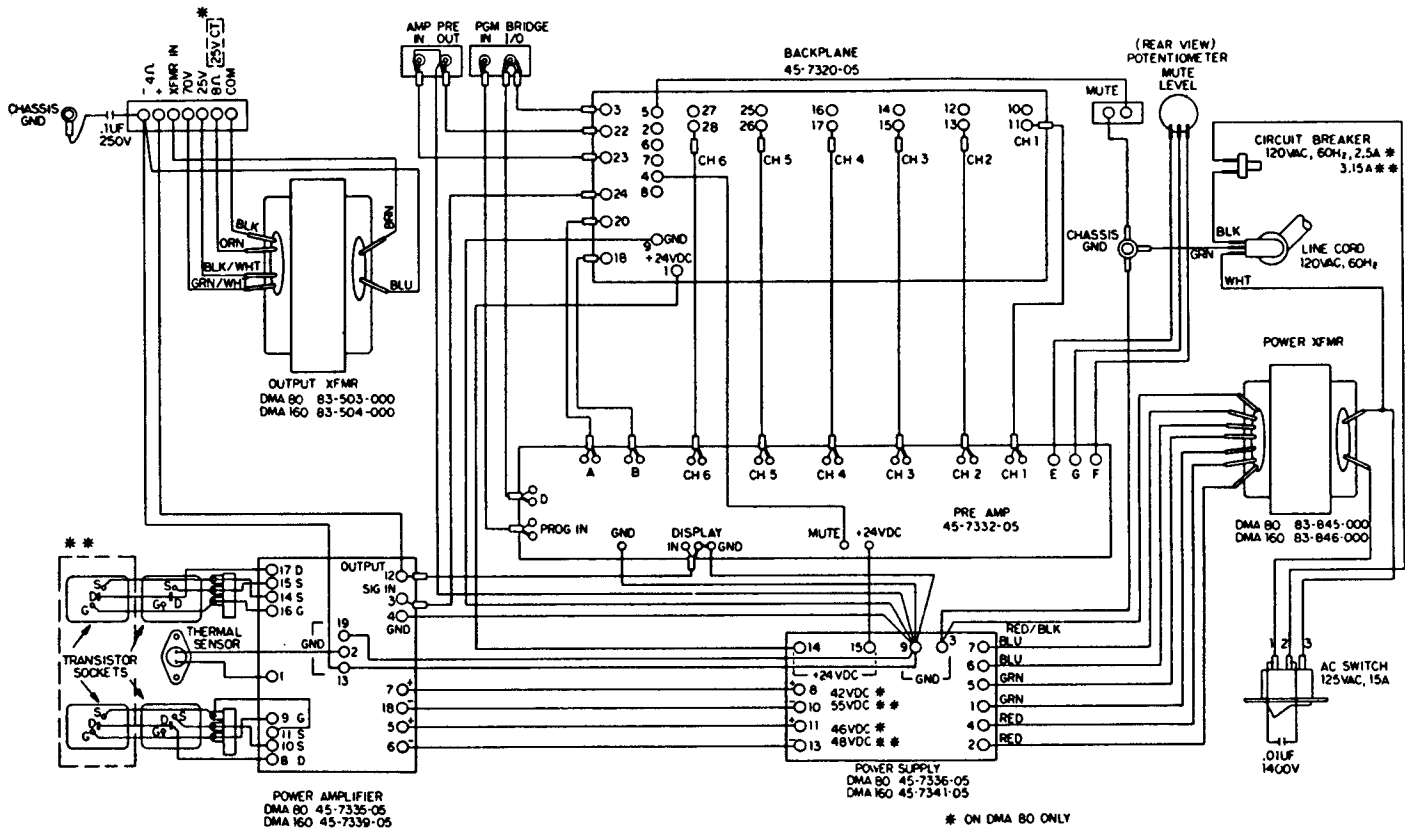

DMA-80, DMA-160 – Wiring Diagram