

INTRODUCTION

The model CHB100 is a general purpose 100-watt public address amplifier. It features five separate inputs with facilities for selection and mixing of up to three inputs. A master volume control provides control of overall gain. Separate Bass and Treble controls are incorpor-

ated for adjusting tonal balance.

Outputs are provided for all standard speaker impedances and for operation with 25-volt and 70-volt long line speaker systems. Two quick disconnect type plugs permit quick connection of speaker system.

TECHNICAL SPECIFICATIONS

USEABLE POWER: 100 watts at 5% distortion

FREQUENCY RESPONSE: 20 to 20,000 Hz, ± 2 db

HUM & NOISE:

MIC Input: 65db below rated power

AUX Input: 80db below rated power

GAIN:

MIC Input: 125db

AUX Input: 100db

MAG Phono Input: 115db

SENSITIVITY:

MIC Input: 4 millivolts

AUX Input: 0.2 volts

MAG Phono Input: 12 millivolt Hz

INPUTS: 2 Microphone (high impedance), 1 magnetic phono and 2 auxiliary (high impedance, 100 Ω level)

OUTPUTS: 4, 8 and 16 ohm systems, 25/70/100

ohms) and 70-volt (80 ohms) line, 2 quick disconnect sockets and connectors provided in addition to screw terminals.

tone CONTROL ACTION:

TREBLE: +12 to -15db at 10 kHz

BASS: +14 to -9 db at 50 Hz

CONTROLS: Microphone No. 1 Volume, Input 2 Volume, Input 2 Selector Switch, Aux1/2 Volume, Master Volume, Bass, Treble, Power and Balance Adjustment.

TUBES: Total of 7 (6EU7, 11AX7, 6C4, 4-7868) plus 3 silicon rectifiers.

POWER CONSUMPTION: 300 watts, 105-125 volts, 50 to 60 cycles, AC

DIMENSIONS: 15-3/4" wide, 6-3/4" high, 10" deep

WEIGHT: 26 lbs.

ACCESSORIES

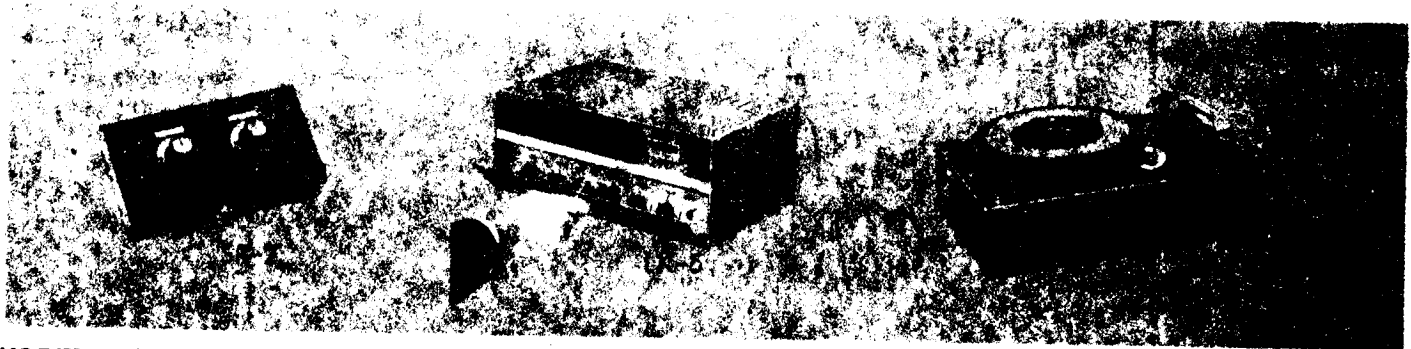

MODEL SR2 REMOTE CONTROLLER

Permits the user to control the gain of the Mic 1 and Mic 2/Mag Phono inputs from distances up to 2,000 feet from amplifier without sacrificing power or signal quality. Allows you to mix and fade the two signal inputs.

MODEL LK-5 LOCKING PLATE

Model LK-5 Locking Plate is designed to prevent unauthorized tampering with controls of amplifier. Comes complete with instructions and a set of two keys. As a safety factor, key cannot be removed when lock is in open position.

MODEL LPC-4 PHONO PLAYER TOP

Model LPC-4 is a complete 4-speed phono-player designed to be mounted directly on top of the amplifier. The unit comes complete with

all necessary hardware. It can be easily installed and connected to amplifier with only a screwdriver. It includes a 4-speed vibration-isolated turntable and tone arm housing a dual-stylus turnover cartridge.

MODEL WMT-1 LINE MATCHING TRANSFORMER

Used with this amplifier for distribution of background music directly from a leased telephone line, wired music systems or any 0 level 500/600 ohm line. Provides an impedance match between 500/600 ohm balanced line and high impedance input of amplifier. The WMT-1 has a 3-screw terminal strip for input connections and output. No wiring or soldering required for making normal connections between amplifier and input or output lines. Slight modification permits WMT-1 connection to MIC input of amplifier.

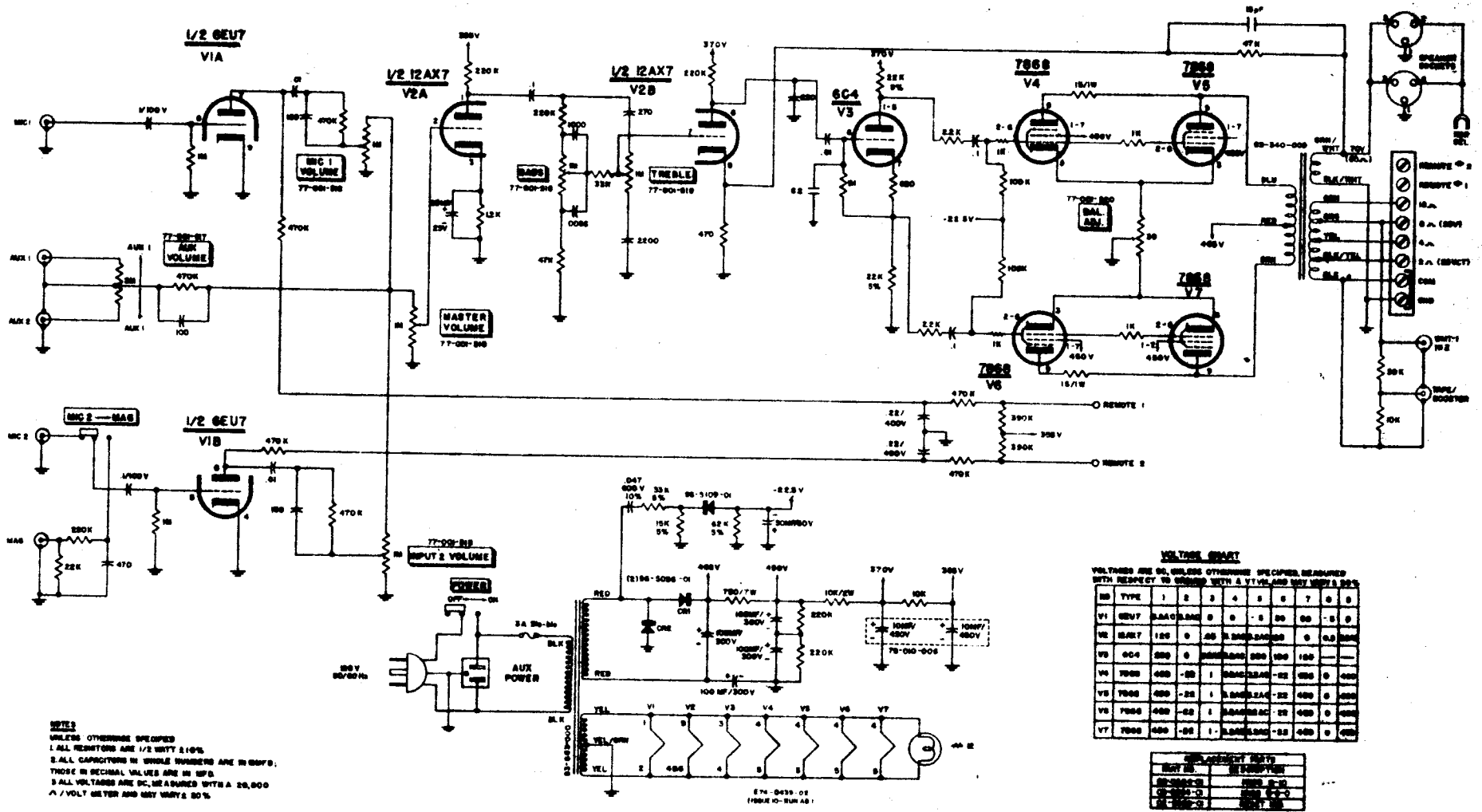

Figure 3 - Schematic Diagram CHB100