



Soundcraftsmen Model TG-2209-600 Twin-Graphic Octave Equalizer

MANUFACTURER'S SPECIFICATIONS
Maximum Input & Output Level: +20 dBm into 600 ohms (8 V rms).
Harmonic Distortion: Less than 0.05 per cent @1.0 V.
Gain: Unity, ±0.5 dB; Controllable, +6dB, -12 dB.
Frequency Response: Controls centered, 20 Hz to 20,480 Hz ±0.5 dB.
Noise: 110 dB below maximum output.
Rated Load: 600 ohms.

Input Impedance: 600 ohms; switchable, greater than 100 kilohms.
EQ Center Frequencies: 30, 60, 120, 240, 480, 960, 1920, 3840, 7680, and 15,360 Hz.
Boost/Cut Range: ±12 dB at octave center frequencies.
Shelving: Low, 100 Hz @ 12 dB/Octave rolloff; High, 10 kHz @ 12 dB/Octave rolloff.

General Specifications
Dimensions: 19 in. (48.3 cm) W x 5 1/4 in. (13.3 cm) H x 9 in. (22.9 cm) D, notched for rack mounting.
Weight: 18 lbs. (8.16 kg).
Price: \$550.00.

Graphic equalizers have become important sound tailoring tools in both the home audio market and the professional sound field. While the basic functions of an equalizer are essentially the same for both applications, the pro user might find it a bit awkward to use an equalizer intended for home entertainment systems in his sound reinforcement or studio applications. For this reason, Soundcraftsmen offers their Model 2209-600 Equalizer—a unit designed with the professional user in mind.

Examining the brushed, black-anodized aluminum front

panel of the 2209 we find the usual 10 slider controls for each of two channels. Each control is calibrated in 2 dB steps from -12 dB to +12 dB, and each is marked with its center frequency, as indicated in the specifications shown above. There are no detent "stops" at the "flat" positions so a little care must be taken when desiring to set a control at its exact central position. Centered between the two banks of slider controls are a pair of overall-gain slider controls, above and below which are LED indicators for each channel. These controls permit the user to adjust input and output levels for

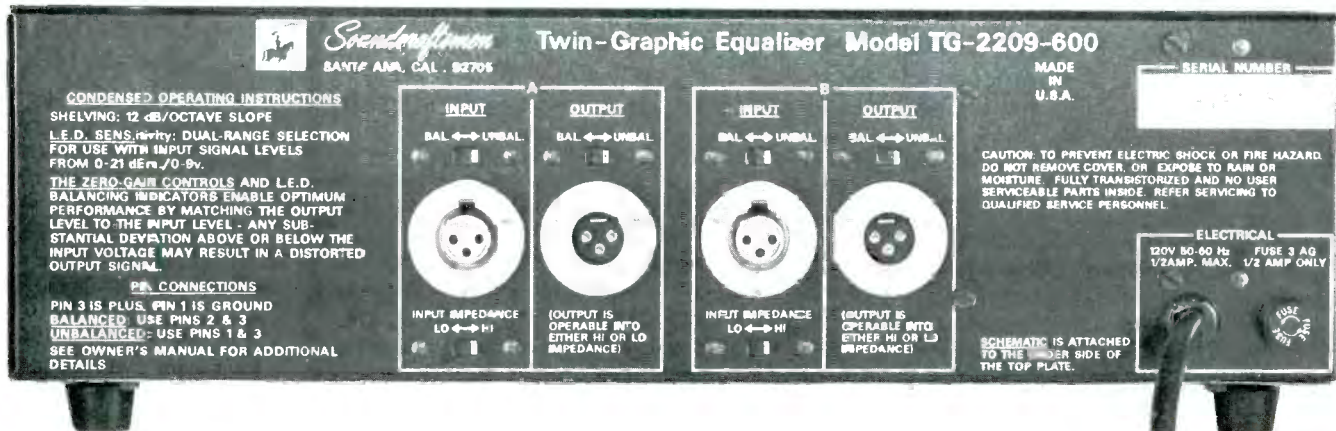

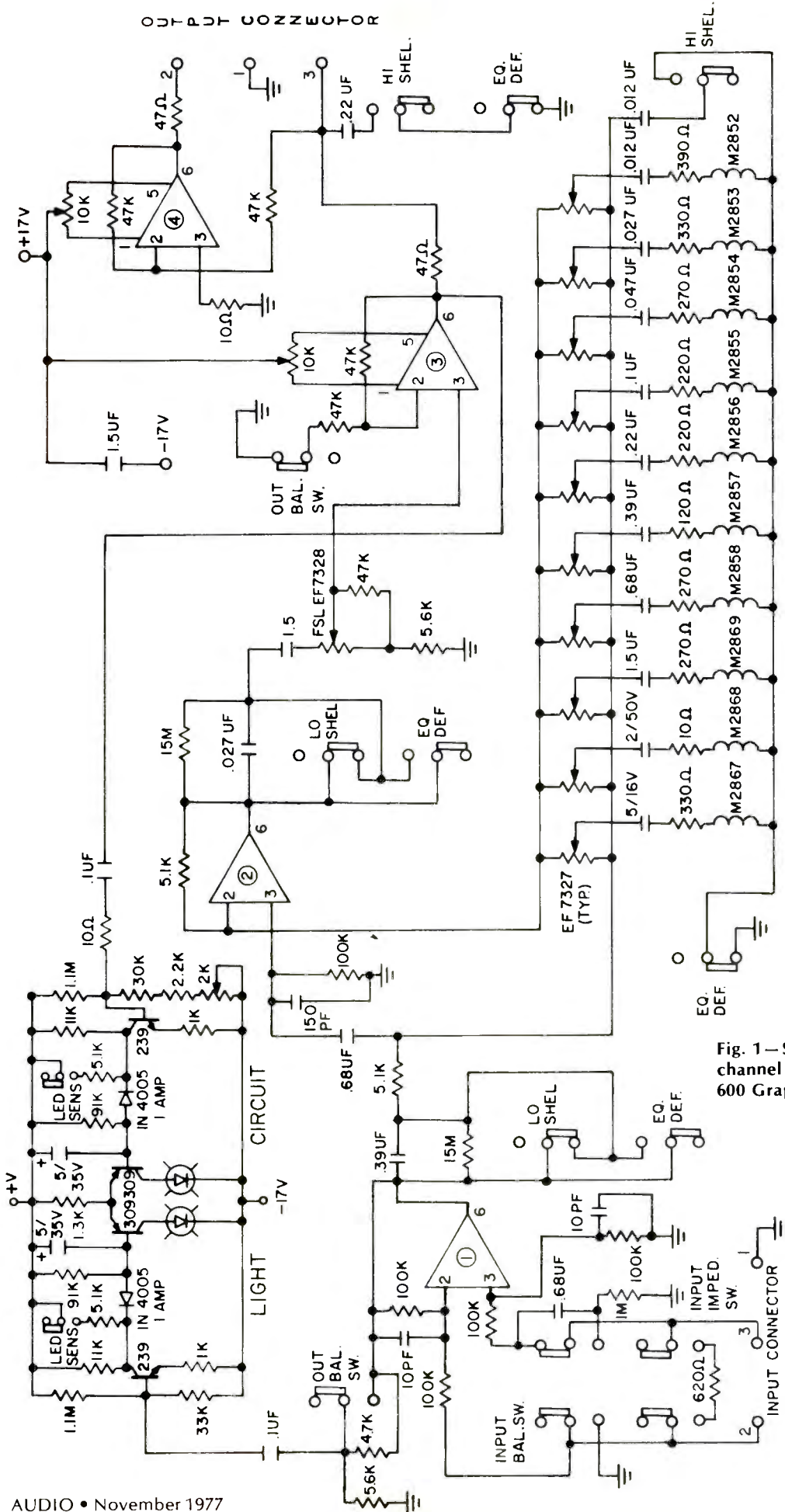
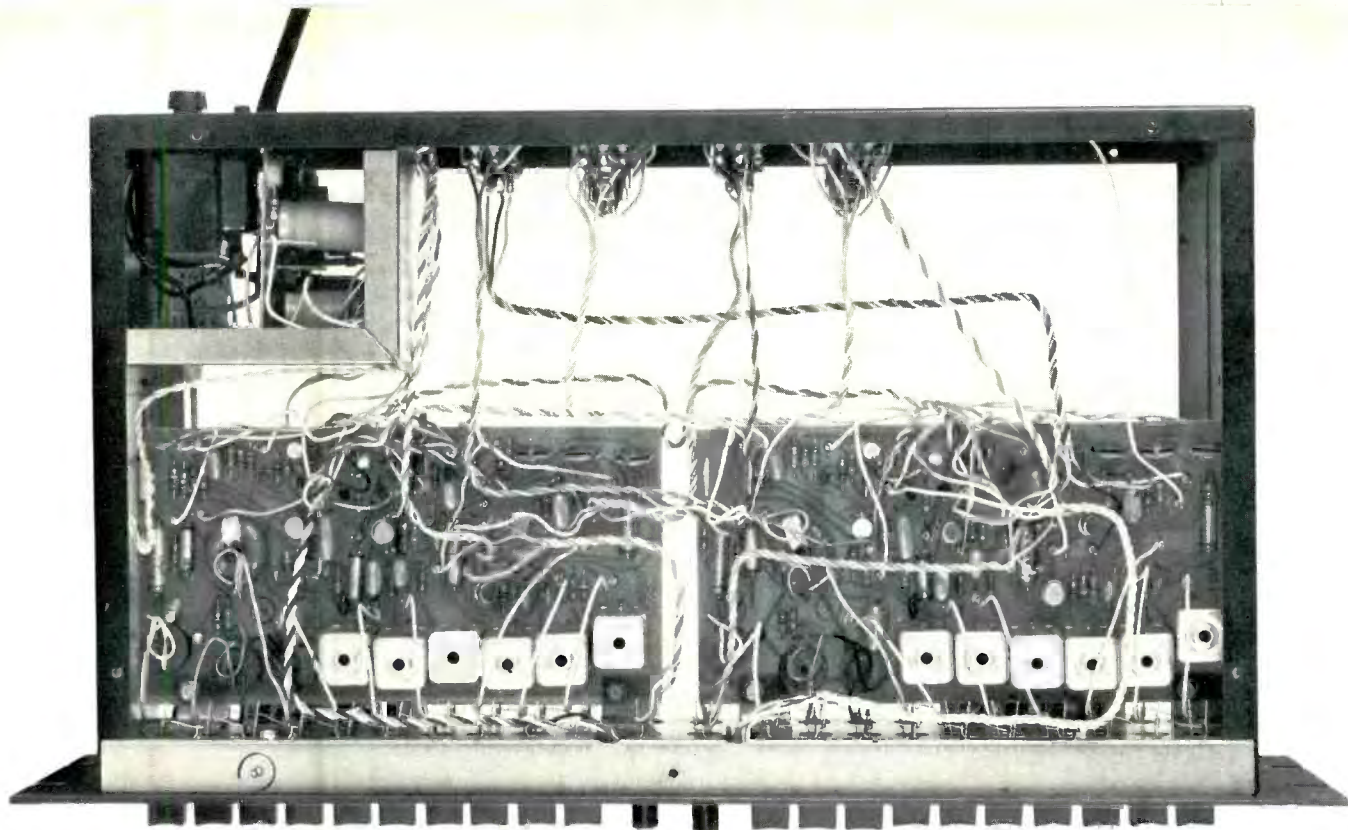

Fig. 1 - Schematic diagram of one channel of the Soundcraftsmen TG-2209-600 Graphic Equalizer.



unity gain after equalization settings have been made. The controls are moved until, with signals applied, upper and lower LED indicators flash at the same light intensity.

At the lower left of the panel is a power *On/Off* switch surmounted by a power/on indicator light. Symmetrically positioned beneath each bank of octave controls are four push buttons for each channel. The first of these alters the sensitivity of the unity-gain LEDs. With these buttons out, input levels of 10 dBm or less will provide proper LED indications. If input levels exceed 10 dBm, the buttons are depressed for accurate indications. The second button is an equalization defeat switch which permits instant comparison between equalized and non-equalized (direct) sound. The remaining two buttons per channel provide low-frequency and high-frequency shelving beginning at 100 Hz and 10 kHz, or roll-off below those corner frequencies at a rate of 12 dB per octave.

Examination of the rear panel of the TG-2209 shows up the major differences between a "home" equalizer and a

Fig. 2—Composite display of the octave-by-octave boost and cut range.

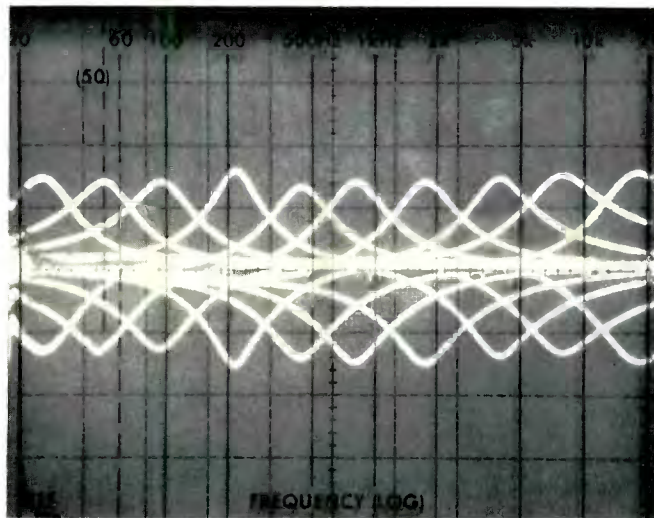

professional unit such as this. To begin with, input and output connectors are three-terminal XLR (Cannon) types, female for inputs, male for outputs. Standard wiring is used, with pin 3 being positive, and Pin 1 grounded. For balanced input and output connections, pins 2 and 3 are used, while for unbalanced operation, pins 1 and 3 are selected. Below each input connector is an input impedance slide switch which alters impedance from 600 ohms to high impedance. Above each input connector is another slide switch which selects proper gain of the system for balanced or unbalanced operation (effectively compensating for the 6-dB signal loss which results when unbalanced input signals are applied to the input connectors). The rear panel also has a convenience a.c. receptacle and a line fuseholder containing a half-ampere fuse.

Circuit boards used in the TG-2209 and visible in the photo of the insides of the unit are made of military-grade G-10 glass epoxy material. In addition to the individual LC filters used for each octave, low-noise carbon film resistors are used in critical circuits and the switch contacts are gold plated. Wiring employs solderless wire-wrap technique throughout. Inductances used in the octave filters are either toroidal or ferrite core, depending upon the center-frequency of the filter in which they are used. Op-amps are used at the input and output circuits. An electronically regulated power supply provides the required plus and minus 17 volts d.c. for the active op-amp circuits. A complete schematic diagram of the TG-2209 (one channel only), is reproduced in Fig. 1.

Laboratory Measurements

With all octave controls set to their flat position and the equalizer in the circuit, frequency response measured flat from 15 Hz to 25 kHz within ± 1.0 dB. Under the same test conditions, total harmonic distortion at any frequency within the audio range measured no more than 0.03 per cent. Even with all controls set to their maximum "boost" position, harmonic distortion increased only to 0.075 per cent. Overload occurred with an input or output of approximately 10 volts (providing the gain adjust controls were adjusted for unity gain under all conditions of measurement).

Figure 2 illustrates the maximum adjustment range for

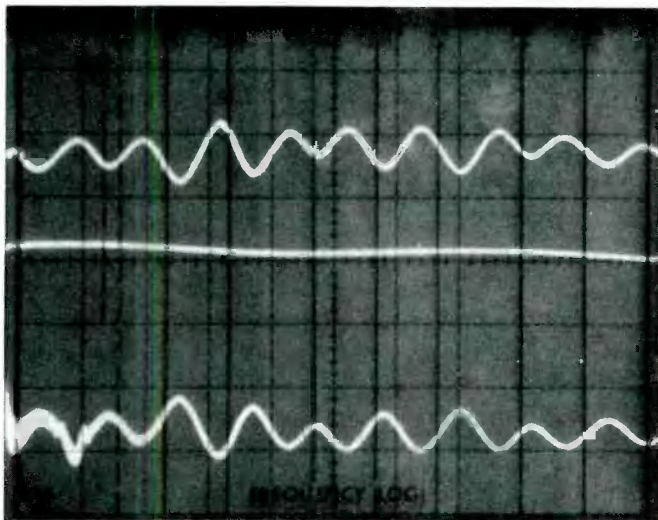

Fig. 3—The upper trace shows the response with all controls at maximum boost; lower trace at maximum cut, and the center trace shows controls set at the mid or “0” position.

each of the octave controls of a single channel on the TG-2209. Center frequencies were calibrated extremely accurately.

Figure 3 illustrates what happens if all octave controls are set either to their maximum boost or maximum cut positions (the straight line in the center of this display represents the reference level when all controls are set to their mid-positions) and helps to explain the importance of the “gain

adjust” controls and the LED indicators. Note, too, that with all controls set to minimum (greatest cut), the overall gain loss is greater than the increase in gain when all controls are set for maximum boost. It is this characteristic of the filters which, no doubt, prompted the designers to provide an asymmetrical range of gain adjustment (+6 db to -12 dB) for readjustment of the system to unity gain.

Use and Performance Tests

As Soundcraftsmen rightly points out in the last paragraph of their well-written instruction booklet, obtaining gain in an audio system “is *Not* the function of an equalizer. *It is not an amplifier*; it is designed only to tailor an incoming signal voltage to the desired curve and to put out a modified curve at exactly the same voltage.” This, the TG-2209 does very well indeed. One test we always employ during check-out of a graphic equalizer is to set all controls flat and listen to music, alternately depressing and releasing the equalizer-defeat switch. If we can detect no audible difference, we are reasonably convinced that the equalizer under test is not contributing any form of distortion of its own, and that is exactly what happened with the TG-2209. While there is a fair amount of interaction between adjacent controls of this unit, we had no trouble equalizing the playback monitor system in our newly constructed “home” recording studio with the aid of the test record (pink noise, in octave segments) supplied with the TG-2209 and a calibrated microphone/sound pressure meter which we own. As we said earlier, the chief difference between this model and other 10-band equalizers offered by Soundcraftsmen is its emphasis on professional interface—an important difference if you are involved with pro audio equipment and want a reasonably priced octave equalizer as part of your installation. *Leonard Feldman*

Enter No. 93 on Reader Service Card