



**RENKUS-HEINZ**

*Smart Systems*

## OPERATION MANUAL

---

**X22** PROCESSOR

---

**PM22-12** PROGRAM MODULE

---

**PM22-15** PROGRAM MODULE

---

**Introduction**

The X22 processor provides two independent channels of two way crossover, equalization and protection for specific Renkus-Heinz speaker systems.

The X22 with PM22-12 program module is designed to operate systems with a 12" woofer.

The X22 with PM22-15 program module is designed to operate both single 15" woofer systems (with the switch in the SR-1 position) and dual 15" woofer systems (with the switch in the SR-2 position).

Please carefully read the following instructions to ensure proper connection and operation of your Smart System.

**Front Panel Features**

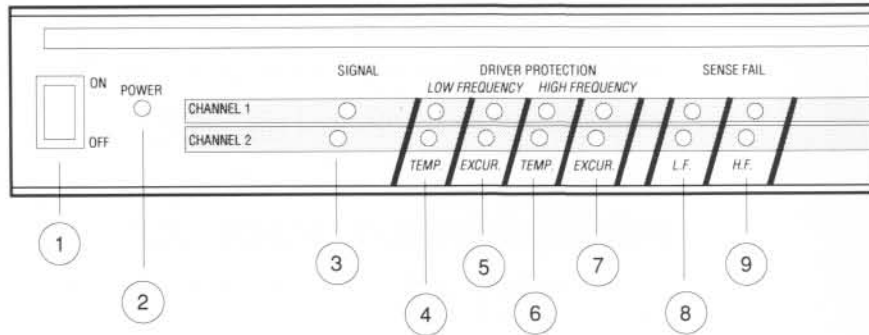

1) Power on / off switch

A muting circuit is automatically activated at power turn-on to prevent loud turn-on transients reaching the speakers just in case the power amplifier has already been turned on (the power amplifier should be turned on last for added safety).

2) Power LED

A green LED indicates that power is being supplied to the processor.

3) Signal LED

A green LED indicates that a signal is present at the processor input. A separate LED is provided for each channel.

**Driver Protection Indicators**

These eight yellow LED's (four per channel) indicate activation of the protective circuits. Occasional operation indicates optimum system utilization, however extended LED illumination indicates that the system is inadequate for its current use.

Additional equipment should be used to bring protection operation down to occasional activation.

4) Low Frequency Thermal LED

Indicates operation of the Low Frequency channel gain reduction circuit.

5) Low Frequency Excursion LED

Indicates operation of the Low Frequency channel equalization circuits.

6) High Frequency Thermal LED

Indicates operation of the High Frequency channel gain reduction circuits.

7) High Frequency Excursion LED

Indicates operation of the Spectrum Power Transfer circuits which control the energy distribution between H.F. and L.F. drivers.

8) Low Frequency Sense Fail

Indicates that the low frequency channel is not receiving a sense signal. Also indicates activation of gain reduction on this output, which will prevent possible component damage.

The circuit will continually attempt to reset so that a "pumping" audio signal from this channel will be heard. When the sense line is connected normal operation will be restored. Each sense fail function operates independently.

9) High Frequency Sense Fail

Indicates that the high frequency channel is not receiving a sense signal.

**Sense Fail Indicators**

## Program Module

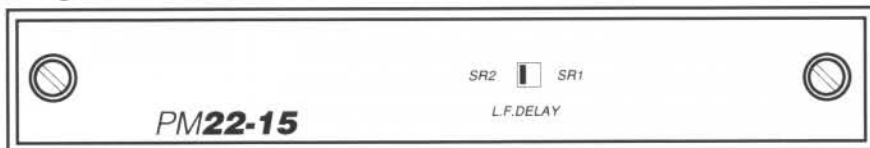

*Be certain to turn the AC power off before attempting to remove or change the Program Module.*

*Damage to the system may result if the module is removed with the power on since this module controls all of the protective circuit threshold levels.*

### SR1 / SR2 L.F. Delay Switch

On the X22-15 program module a switch is provided to select the proper low frequency channel time correction. If single 15" woofer cabinets are being used (SR-1 or W-1) the switch should be in the SR-1 position. If dual 15" woofer cabinets are being used (SR-2) the switch should be in the SR-2 position.

## Rear Panel Features

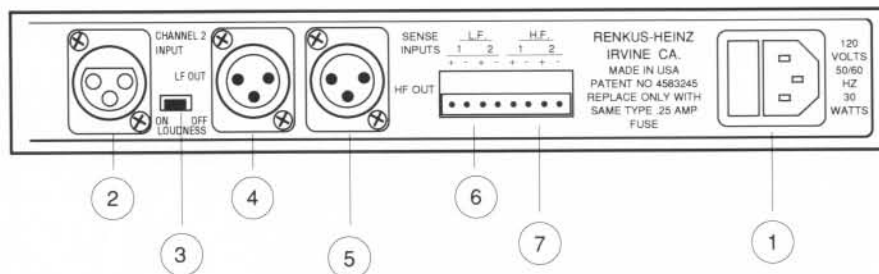

### 1) AC Power Receptacle and Fuse

This receptacle accepts the IEC 320 / CEE-22 power connector. A line cord with appropriate matching connector is supplied with the processor.

*Before connection check the noted AC voltage requirement on the rear panel and make certain that the unit is connected to the proper voltage. Failure of the unit will result if a 120 volt processor is connected to 220 volt power.*

This receptacle also contains a 0.25 amp 5x20 mm mains fuse. The power cord must be removed to gain access to the fuse door. When the fuse door is opened the innermost fuse is the active fuse and the outer fuse is a spare.

### 2) Input Connector

Balanced female XLR connector. Pin 1 is chassis ground. Pins 2 and 3 are the electronically floated signal connections. For proper operation both pins 2 and 3 must be connected, although if the processor is connected to a single ended source either pin 2 or pin 3 may be grounded with no change in the system gain.

Proper connection for an unbalanced source is signal to pin 3 and ground to pin 2. Pin 1 connection to source ground is optional and should be selected to minimize hum.

### 3) Loudness Switch

This switch allows operation of the automatic loudness compensation. When "on", loudness equalization will automatically be added at low output levels. As the acoustic output increases this equalization is automatically removed.

### 4) Low Frequency Output

A balanced male XLR connector provides signal to the low frequency power amplifier. This output should be connected to a balanced input.

Pin 1 is chassis ground, Pins 2 and 3 are signal. If it is necessary to connect this output to a single-ended input, connect ground to pin 1 and use pin 3 for signal (if a polarity reversal is needed pin 2 can be used for signal). Single-ended connection of the output results in a 6 dB gain reduction.

### 5) High Frequency Output

A balanced male XLR connector provides signal to the high frequency power amplifier. Connections should be made as for the low frequency output above.

## Loudness Compensation

**Sense Inputs**

Two sets of Low Frequency and High Frequency sense input are provided. If only one sense input is needed either one may be used.

The terminal strip used for these connections will accept 14 to 22 AWG wire and can be unplugged from the chassis for ease of wiring or processor replacement.

*If the sense inputs are not connected and the output level exceeds a nominal level, the processor will indicate a Sense Fail and limit the associated output channel.*

6) Low Frequency Sense Input

Connects the output of the low frequency power amplifier to the processor sensing circuits. Each low frequency amplifier output should be connected to its appropriate processor. These inputs are balanced and insensitive to polarity.

7) High Frequency Sense Input

Connects the output of the high frequency power amplifier to the processor sensing circuits. Each high frequency amplifier output should be connected to its appropriate processor. These inputs are balanced and insensitive to polarity.

Proper connection of the processor is vital to reliable high output operation of your Renkus-Heinz Smart System. Extreme care should be taken to ensure that both signal and sense connections are properly made and that protection circuits are functioning.

**Input and Output Cables:** All inputs and outputs are actively balanced. The relative polarity is set to match the specific R-H speaker system for which the processor is designed, assuming that both the High Frequency and Low Frequency amplifier channels have the same polarity.

**Set up and Operation**

**Input Wiring**

If it is necessary to connect the input to an unbalanced source, the signal should be connected to pin 3 and the source ground to pin 2.

Connection of pin 2 (source ground) to pin 1 (processor ground) is optional and should be selected to minimize system hum. Since the processor has an instrumentation type input stage both pins 2 and 3 must be connected.

A 20 dB loss of gain results if only pin 2 or only pin 3 and pin 1 (ground) are used for an unbalanced input. Either pin 2 or pin 3 can be used as an unbalanced input, but the other pin must be connected to ground.

The outputs (both H.F. and L.F.) are also actively balanced. If it is required to connect the output to an unbalanced load, pin 3 (signal) and pin 1 (ground) should be used. Pin 2 should be unused (do not connect pin 2 to ground). This connection results in a 6 dB reduction of system gain.

If only one output (H.F. or L.F.) is connected unbalanced, the gain of the amplifier with the balanced input should be reduced 6 dB to obtain proper gain balance.

**Output Wiring**

*unbalanced input connection*

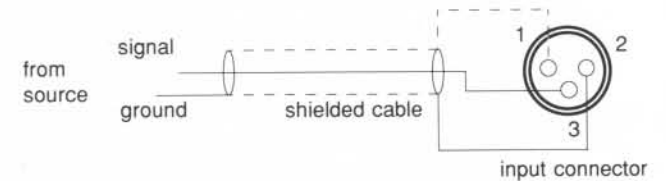

*unbalanced output connection*

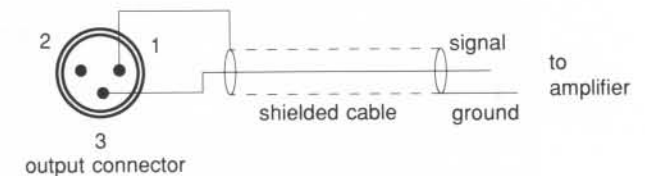

## System Polarity

The internal polarity of the processor has been set to provide compatibility with older Renkus-Heinz Smart Speaker Systems assuming that both H.F. and L.F. amplifier channels have the same polarity. The following chart indicates the relative polarity of a properly connected system.

	Input + to pin 3	Input + to pin 2
L.F. Output	+ pin 3 - pin 2	+ pin 2 - pin 3
H.F. Output	- pin 3 + pin 2	- pin 2 + pin 3
L.F. Power Amp out (Pin 3 +)	+	-
H.F. Power Amp out (Pin 3 +)	-	+
L.F. Speaker out	+	-
H.F. Speaker out	+	-

## Sense Input Cables

The sense input cables must be connected between each amplifier output and the processor. The processor sense inputs are balanced and phase is not critical. The processor provides two sense inputs for each output so that if two amplifier channels are being driven from one processor output, both amplifier outputs can be sensed. The summing circuit in the processor will automatically select the larger of the two signals.

The terminal block provided on the processor is a pluggable type (for ease of wiring and processor replacement), and will accept 14 to 22 AWG stranded wire.

Strip the wire approximately 1/4", insert into the appropriate terminal and tighten the contact screw in the top of the terminal block. If access to the terminal block is difficult it can be unplugged (pull straight back) to install the wire, and then reconnected to the processor.

When the system is operated above a nominal level and one or more sense connections are not made, a warning LED (sense fail) on the front panel is illuminated, and the gain of the channel is reduced. When the proper connection is made normal operation will be restored.

Standard Smart Speaker Systems use either one chassis mount male four circuit Hubbell connector or one chassis mount male and one female Hubbell connector. The female connection is provided on 8 ohm systems so that two cabinets may be looped together to form a 4 ohm load.

## Speaker Cable

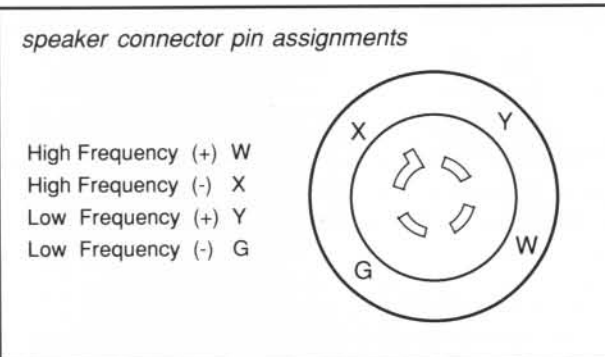

The size of the speaker wiring needed depends on the length of the cable. We generally recommend the use of 12 AWG for cables up to 30 meters. The following table shows the signal loss in 30 meters (approximately 100 ft) of cable driving a 4 ohm load:

## Signal Loss

Wire Gauge	10 AWG	12 AWG	14 AWG	16 AWG	18 AWG
Signal Loss	.44dB	.69dB	1.07dB	1.65dB	2.49dB

## Multiple Power Amplifiers

In larger systems it may be economical to use several amplifiers with each processor. The X22 processor provides sense inputs for two amplifier channels per processor output.

If more than two amplifier channels are connected to one processor output and both sensed channels fail, then the processor Sense Fail protection circuits will be activated and all remaining active amplifiers will be reproducing a lower level, "pumping" audio signal. If an additional safety factor is required, SG-2 sense gates should be used to connect the other power amplifier channels to sense inputs.

The following diagram indicates the proper connection for four amplifier channels per output (only one of the X22 channels is shown).

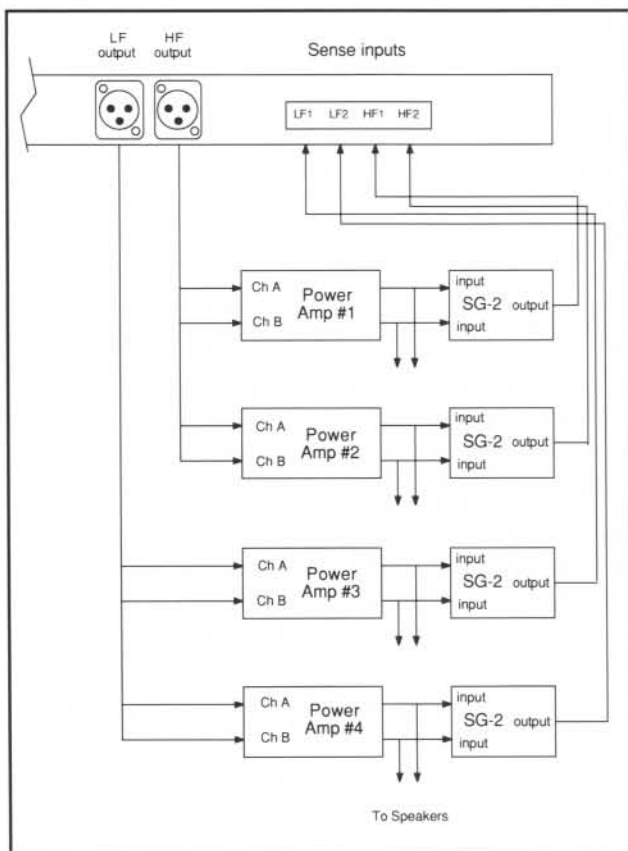

In most installations it is best to mount the processor in the power amplifier rack. In this arrangement the sense connections are short and easy to verify.

However, keep in mind that almost all amplifiers radiate 50 / 60 Hz magnetic hum field from their power transformers. Some amplifiers are worse than others. It may be necessary to provide space and / or shielding between the processor and the nearest amplifier to eliminate induced hum.

*Due to the depth and weight of the processor it is imperative that the processor be supported at the rear of the chassis if it is used in a portable application.*

We strongly recommend use of the Renkus-Heinz P1500 power amplifier. This amplifier, in addition to satisfying the power and sensitivity requirements, provides additional protection from clipping and high frequency oscillation.

Renkus-Heinz two way Smart Systems require amplifiers capable of at least 200 watts into 8 ohms for both high frequency and low frequency channels. While some range on sensitivity can be accommodated by the processor, 1.55 volts RMS for full output is the preferred value.

## Mounting

## Selection of Power Amplifiers

## Typical System Connection

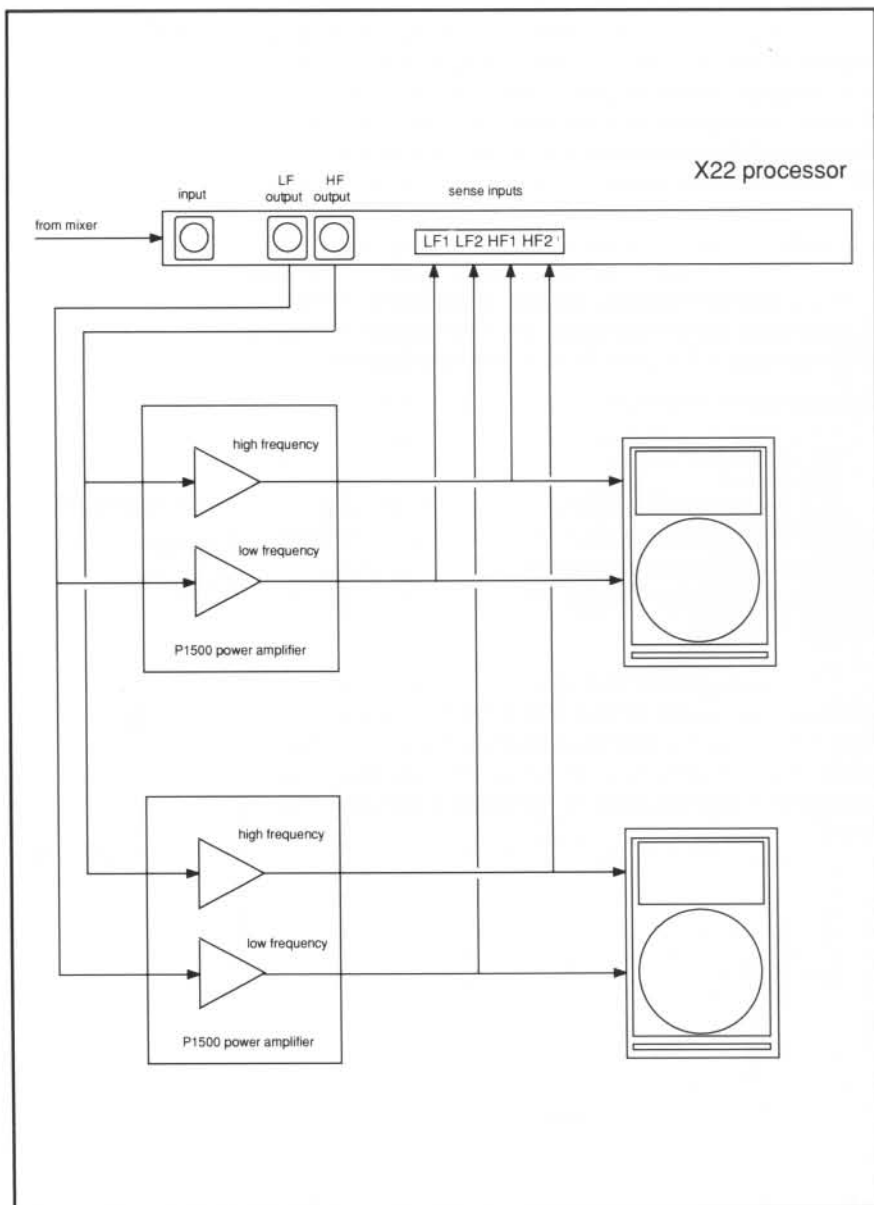

## Verification of Protection Circuit Operation

*Caution: Operating the Smart System at full level can damage your hearing. Wear ear protectors and do not position yourself in front of the speaker systems.*

Before applying power to the Smart System trace and verify all connections.

Make certain that the processor low frequency output is connected to the low frequency power amplifier and that the LF amplifier output is connected to both the LF speaker and the processor LF sense input.

Make certain that the high frequency processor output is connected to the high frequency power amplifier and that the HF amplifier output is connected to both the HF speaker and the processor HF sense input.

Set the power amplifier gain controls to their minimum position. Turn on the processor and adjust your signal source to just illuminate the signal LED's on the processor.

Turn on the power amplifiers and slowly turn the amplifier level controls to their maximum position one at a time. While you are doing this, verify that as the amplifier gain is increased the appropriate response is obtained (i.e. high frequency channel connected to high frequency speaker, etc). Moderate level, full range audio should be heard from the speakers.

Gradually increase the signal level to the processor input until the yellow protection LED's start to illuminate. First thermal, and then excursion LED's should be intermittently lighting. As the level continues to increase the protection LED's will be on for longer periods of time.

*Do not* operate the system at a level where the protection LED's are illuminated continuously. If as you are increasing the level as above you hear a sudden loss of one frequency band and see illumination of a red Sense Fail LED on the processor, this indicates that the noted sense circuit is not connected.

Correct this before proceeding. (The Sense Fail LED will flash and the output in that frequency band will "pump" until the sense connection is properly made).

**Trouble-shooting**

<b>IMPORTANT:</b>	<i>In the event of service being required, we recommend that the product be returned to the factory in the original packing carton. The processor contains no user-serviceable parts. Please refer service to qualified service personnel.</i>
Power LED is not lit	Check for proper connection of power cord to a suitable outlet and verify proper voltage. Check that the mains fuse is intact.
Signal LED's not lit; no sound	Check that the mixer is sending a signal and that the interconnecting wiring is not faulty.
Protection LED's continuously lit	Reduce system gain and / or avoid extreme equalization. Add more amplifier / speaker systems.
Very low system gain	Processor input incorrectly connected.
Low gain from one or both outputs	Processor outputs incorrectly connected - check for unbalanced connection.
Distorted sound	Blown drivers in speaker system. Clipped signal at processor input. 220 volt unit connected to 110 volt outlet.
Sense Fail indicators lit; "pumping" sound from one or both channels	Connection to one or more sense inputs has been lost - trace and reconnect sense lines. Amplifier failed or turned off.

**Technical Specifications**

<p><b>SYSTEM EQUALIZATION</b> LOW FREQUENCY</p> <p>HIGH FREQUENCY DRIVERS HORNS</p> <p><b>SPT PROTECTION</b> SENSE INPUT IMPEDANCE</p> <p><b>WOOFER PROTECTION</b> operates on</p> <p><b>DRIVER PROTECTION</b> operates on</p> <p><b>PROCESSOR</b> CROSSOVER SLOPE CROSSOVER FREQUENCIES INPUT IMPEDANCE NOMINAL INPUT LEVEL FREQUENCY RESPONSE THD &amp; IM DISTORTION HUM &amp; NOISE OVERALL GAIN GROUP DELAY</p> <p><b>INDICATORS &amp; SWITCHES</b> SWITCHES</p> <p>INDICATORS</p> <p><b>POWER REQUIREMENTS</b></p> <p><b>DIMENSIONS (W X H X D)</b></p> <p><b>NET / SHIPPING WEIGHT</b></p>	<p>Loudness Compensation Enclosure Equalization</p> <p>R-H 1" and 2" Drivers R-H CBH 500 / 820 / 1000</p> <p>47kΩ balanced (four inputs each channel)</p> <p>Loudness comp., Enclosure EQ and low-pass gain</p> <p>Crossover frequency and high-pass gain</p> <p>18 dB / octave 1000 Hz (15"), 1500 Hz (12") 12 KΩ balanced 1.23 volts ±0.5dB, 20-20kHz (no EQ) &lt;0.01%, 20-20kHz (no EQ) &lt;95 dBm, 20-20kHz (no EQ) Unity, 20-20kHz (no EQ) Better than 50µsec</p> <p>Power on (front) Loudness off (rear) SR-1 / SR-2 delay (PM22-15 Plug-in program module) Power on, Excursion and Thermal Overload Signal present Sense fail</p> <p>105-130V 50/60 Hz 210-250V 50/60 Hz 30 watts maximum</p> <p>19" x 1.75" x 11" (48.3 cm x 4.5 cm x 27.9 cm)</p> <p>8.0 lbs (3.6 kg) / 9.5 lbs (4.3 kg)</p>
---	--