

OPERATION MANUAL

P2400 • P2700

Dual Channel Power Amplifiers

C12 • C22 • L20

Plug-In Controller Modules



RENKUS-HEINZ

Cautions

Sicherheitsvorschriften

CAUTION

TO AVOID ELECTRIC SHOCK, DO NOT INSERT FINGERS OR OBJECTS INTO ANY OPENINGS IN THE CABINET

VORSICHT

UM ELEKTRISCHEN SCHLAG ZU VERMEIDEN, KEINE FINGER ODER GEGENSTÄNDE IN ÖFFNUNGEN DES GEHÄUSES STECKEN

WARNING: TO PREVENT FIRE OR ELECTRIC SHOCK, DO NOT EXPOSE THIS EQUIPMENT TO RAIN OR MOISTURE

WARNUNG: ZUR VERMEIDUNG VON FEUER ODER ELEKTRISCHEN SCHLÄGEN DAS GERÄT NICHT MIT REGEN ODER FEUCHTIGKEIT IN BERÜHRUNG BRINGEN



Explanation of Graphical Symbols
The lightning flash with arrowhead symbol, within an equilateral triangle, is intended to alert the user to the presence of uninsulated "dangerous Voltage" within the product's enclosure that may be of sufficient magnitude to constitute a risk of electric shock to humans.



The exclamation point, within an equilateral triangle is intended to alert the users to the presence of important operating and maintenance (servicing) instructions in the literature accompanying the product.



Erklärung der graphischen Symbole
Der Blitz mit nach untenzielendem Pfeil in einem gleichseitigen Dreieck weist den Benutzer auf das Vorhandensein einer unisolierten, "gefährlichen Spannung" im Gehäuse hin, die stark genug sein kann, einer Person einen gefährlichen elektrischen Schlag zu versetzen.



Das Ausrufezeichen in einem gleichseitigen Dreieck weist den Benutzer auf wichtige Betriebs- und Wartungsvorschriften in den beiliegenden Unterlagen des Gerätes hin.

CAUTION

**RISK OF ELECTRIC SHOCK
DO NOT OPEN**



CAUTION: TO REDUCE THE RISK OF ELECTRIC SHOCK, DO NOT REMOVE THE COVER. NO USER-SERVICEABLE PARTS INSIDE. REFER SERVICING TO QUALIFIED SERVICE PERSONNEL

VORSICHT

GEFAHR EINES ELEKTRISCHEN SCHLAGES NICHT ÖFFNEN



VORSICHT! UM DAS RISIKO EINES ELEKTRISCHEN SCHLAGES ZU VERMINDERN, ABDECKUNG NICHT ENTFERNEN. KEINE BENUTZER BEDIENUNGSTEILE IM INNERN. BEDIENUNG NUR DURCH QUALIFIZIERTES BEDIENUNGSPERSONAL.

CAUTION

**RISK OF ELECTRIC SHOCK:
OPEN ONLY IF QUALIFIED AS
SERVICE PERSONNEL**

To reiterate the above warnings: servicing instructions are for use by qualified personnel only. To avoid electric shock, do not perform any servicing other than that contained in the Operation Instructions unless you are qualified to do so. Refer all servicing to qualified personnel.

VORSICHT

GEFAHR EINES ELEKTRISCHEN SCHLAGES: NUR VON QUALIFIZIEREM WARTUNGSPERSONAL ZU ÖFFNEN

Eindringliche Warnung: Wartungsvorschriften dienen nur der Benutzung durch qualifiziertes Personal. Zur Vermeidung eines elektrischen Schlages keine anderen als die in den Betriebsvorschriften beschriebenen Wartungsarbeiten ausführen, es sei denn Sie sind dafür qualifiziert. Wartungsarbeiten sind nur von qualifiziertem Wartungspersonal auszuführen.

Table of Contents

Warning Messages	2
Table of Contents	3
Introduction	4
Technical Specifications	5
Front Panel Features	
Status LED's	6-7
Signal LED's	6-7
Output Attenuators	6-7
On/Off Switch	7
Rear Panel Features	
AC Fuse	8
Output Connections	8
Standard Input Module	
Output Mode Selector	8
Input Connections	9
Looping Outputs	9
Ground Lift Switch	9
Loudspeaker Controller Modules	
C12 Loudspeaker Controller Module	10
Input Connections	10
Output Connections	10
C22 Loudspeaker Controller Module	10
Output Connections	10-11
Input Connections	11
Ground Lift Switch	11
C22 Setup Switches	12
L20 Limiter Module	
Looping Outputs	12
HPF Selectors	12
Input Connectors	12
Limit Set Switches	12
Output Mode Selector	13
Ground Lift Switch	13
Amplifier Set-Up and Operation	14
Cooling	14
Mounting	14
Wire Size	14
Performance Verification	14
System Block Diagrams	
Without Controller Modules	15
With L20 Limiter Module	15
With C12 Controller Module	16
With C22 Controller Module	16

Introduction

Congratulations on your purchase of a Renkus-Heinz P2400 or P2700 dual-channel, professional, power amplifier.

Your Renkus-Heinz amplifier has been designed to provide years of trouble-free, high performance operation. We hope you enjoy it.

Your amplifier may include a C12 or C22 loudspeaker controller module or a L20 Limiter Module in place of the standard dual channel input module (see pages 8 to 13 for details). The C12 and C22 controller modules are dedicated companions to a specific Renkus-Heinz loudspeaker. They provide protection circuitry, electronic crossover circuitry and response optimization for their associated loudspeakers.

The L20 is a limiter module with user adjustable limit and HPF controls. It is not "loudspeaker specific" and allows the user to adjust the controls to suit his application.

Caution: If your amplifier includes a C12 or C22, it is configured for use with a particular loudspeaker model and should not be used with any other model. Use of the wrong loudspeaker may result in loudspeaker damage.

Your Renkus-Heinz amplifier was completely tested and inspected before leaving our factory and should have arrived in perfect condition. Please carefully inspect your amplifier and its shipping carton for any noticeable damage, and if any damage is found, immediately notify the shipping company.

Only the consignee may institute a claim with the carrier for any damage incurred during shipping. Be sure to save the carton and all packing materials for the carrier's inspection.

It is also a good idea to save the carton and packing material even though the amplifier arrived in good condition. If shipping the amplifier should ever be required, it should be shipped only in its original factory packing.

Important:

Your Renkus-Heinz amplifier contains no user-serviceable parts and all service should be referred to qualified service personnel. We recommend that it be returned to the factory in its original packing carton if factory service is required.

Technical Specifications

POWER OUTPUT RATINGS: (20HZ to 20 kHz < 0.1% THD)	P2400 250 watts/ch at 8 ohms 350 watts/ch at 4 ohms 700 watts bridged (8 ohm)	P2700 350 500 1000
FREQUENCY RESPONSE:	+0.0, -5 dB, 20 Hz to 20 kHz	
THD (at 1kHz) DISTORTION:	< 0.1% at rated power output (4 ohms)	
SMPTE IMD:	< 0.015 %	
HUM & NOISE:	-100 dB (referred to RPO @ 8 ohms, 20 Hz to 20 kHz)	
CROSSTALK:	> 60 dB @ 400 Hz	
INPUT SENSITIVITY:	1.4 V for RPO @ 8 ohms (P2400) 1.2 V for RPO @ 8 ohms (P2700)	
INPUT IMPEDANCE:	20 K ohms, balanced	
VOLTAGE GAIN:	31 (P2400) 45 (P2700)	
SLEW RATE:	> 30 V/usec (P2400) > 40 V/usec (P2700)	
DAMPING FACTOR:	>200 @ 8 ohms (P2400) >400 @ 8 ohms (P2700)	
MAX. VOLTAGE SWING:	+/- 73 V _p (P2400) +/- 100 V _p (P2700)	
POWER REQUIREMENTS:	120/230 VAC, 50/60 Hz (P2400 - 1400 VA; P2700 - 1500 VA)	
FEATURES:	Temperature, DC @ output, short circuit protection Delayed turn-on with output muting Subsonic and ultrasonic filters Signal & Status LEDs	
COOLING:	Front to rear, variable speed DC fan	
CONSTRUCTION:	All steel closed box construction; 3/16" aluminum face panel	
FINISH:	Black (powder coat)	
FRONT CONTROLS:	Output level attenuators, power on/off,	
REAR CONTROLS:	Stereo/mono/bridging mode selector Ground lift switch	
REAR PANEL CONNECTORS:	Inputs; 3-pin female XLR (pin 2 +) Outputs; 4-pin Neutrik Speakon Looping (controller) output(s); 3-pin male XLR (pin 2 +)	
DIMENSIONS (H X W X D):	3 1/2" H x 19" W x 18" D (depth behind panel) (8.9 x 48.2 x 45.7 cm)	
NET / SHIPPING WEIGHT:	(P2400) 32.1 lbs (14.6 kg) (P2700) 35 Lbs (15.9 kg)	
ASSOCIATED EQUIPMENT:	C12 & C22 plug-in loudspeaker controller modules L20 plug-in limiter module	

Front Panel Features

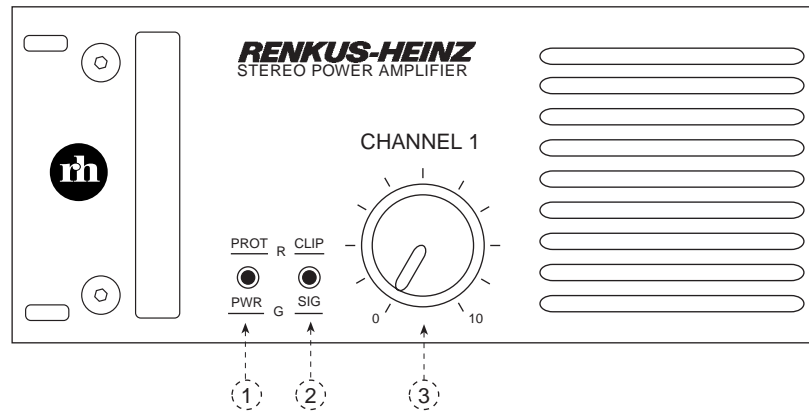

Status LED's

1. Channel 1 Status (Prot/Pwr) LED

The Channel 1 Status LED glows green to indicate the amplifier is on and Channel 1 is operating normally. It glows red to indicate that one or more of the amplifier Channel 1 protective circuits has been activated. The amplifier contains separate over-temperature, DC on output and shorted-load protective circuitry for each channel. Whenever a fault is detected, the offending channel is temporarily "shut down" and the status light turned red to call attention to the problem. The channel will remain "off" until normal operating conditions are restored.

Note. The status LED is also controlled by the C12 & C22 controller and L20 limiter modules and when one of these modules is included, the status LED will glow red when one of these modules' protective circuits has been activated.

It is normal for the Status LED to glow red when the amplifier is first turned on. It will then turn to a steady green as a sign that Channel 1 is on and operating satisfactorily.

Signal LED's

2. Channel 1 Signal (Clip/Sig) LED

The Signal LED indicates the status of the amplifier's Channel 1 signal level. When it is off (not glowing), it shows that no signal is being received. It glows green to indicate a normal signal level and red as an indication that Channel 1 is being driven into clipping. Occasional operation of the red "clip" indication (flickering of the red light) is an indication of optimum system utilization. Extended illumination of the red "clip" indication is a sign the system is being overdriven and should be avoided.

Output Attenuator

3. Channel 1 Output Attenuator

The Channel 1 Output Attenuator controls the gain of Channel 1 in all operating modes. When it is turned fully clockwise, the amplifier will have its maximum rated voltage gain and will deliver its rated output when driven by its rated input signal. As a general rule, setting the attenuator in the full clockwise position provides maximum amplifier headroom; setting the attenuators at a lower level maximizes the system signal/noise ratio.

Important - - When the amplifier is being operated in the bridge output mode, both the Channel 1 and Channel 2 attenuators must be set in the same position to avoid a mismatch in the signal level being sent to each channel.

Front Panel Features

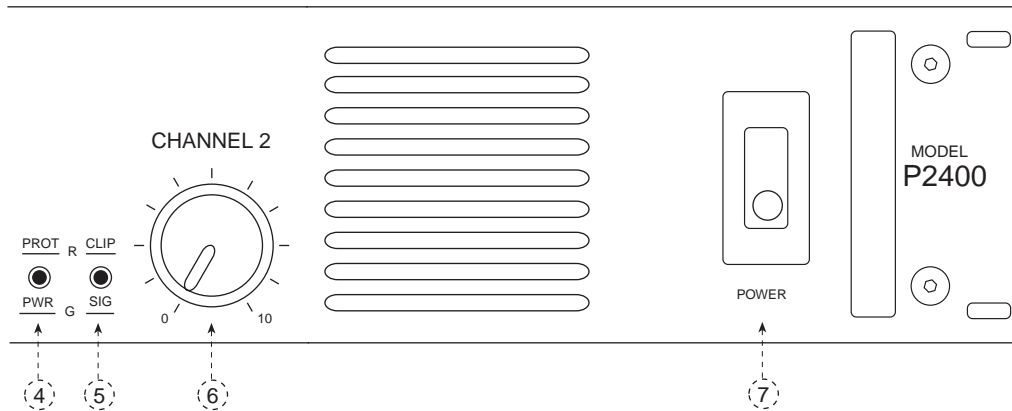

4. Channel 2 Status (Prot/Pwr) LED

The Channel 2 Status LED glows green to indicate the amplifier is on and Channel 2 is operating normally. It glows red to indicate that one or more of the amplifier's Channel 2 protective circuits has been activated. The amplifier contains separate over-temperature, DC on output and shorted-load protective circuitry for each channel. Whenever a fault is detected in Channel 2, the channel is temporarily "shut down" and the status light turned red to call attention to the problem. The channel will remain "off" until normal operating conditions are restored.

Note. The status LED is also controlled by the C12 & C22 controller and L20 limiter modules and when one of these modules is included, the status LED will glow red when one of these modules' protective circuits has been activated.

It is normal for the Status LED to glow red when the amplifier is first turned on. It will then turn to a steady green as a sign that Channel 2 is on and operating satisfactorily.

5. Channel 2 Signal (Clip/Sig) LED

The Channel 2 Signal LED indicates the status of the amplifier's Channel 2 signal level. When it is off (not glowing), it shows that no signal is being received by Channel 2. It glows green to indicate a normal signal level and red as an indication that Channel 2 is being driven into clipping. Occasional operation of the red "clip" indication (flickering of the red light) is an indication of optimum system utilization. Extended illumination of the red "clip" indication is a sign the system is being overdriven and should be avoided.

6. Channel 2 Output Attenuator

The Channel 2 Output Attenuator controls the gain of Channel 2 in all operating modes. When it is turned fully clockwise, the amplifier will have its maximum rated voltage gain and will deliver its rated output when driven by its rated input signal. As a general rule, setting the attenuator in the full clockwise position provides maximum amplifier headroom; setting the attenuators at a lower level maximizes the system signal/noise ratio.

7. Power On/Off Switch

This switch is used to turn power to the amplifier "on" and "off".

Status LED's

Signal LED's

Output Attenuator

On/Off Switch

Rear Panel Features

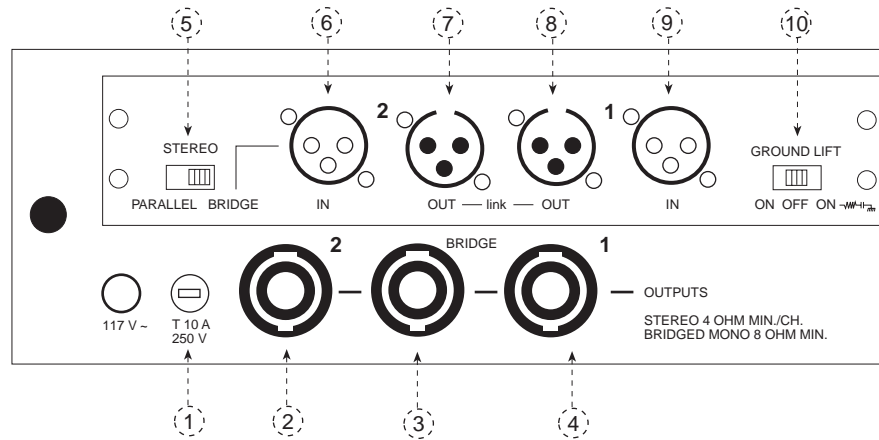

AC Fuse

1. AC Power Cord & Fuse

The fuse holder on the P-2400 accepts a T 10 A, 250 V Fuse; on the P2700 a T 16 A, 250 V.

Before connecting the amplifier, check the AC voltage requirement and make certain the unit is connected to the proper voltage. Failure of the unit will result if a 120 volt amplifier is connected to a 220 volt power line.

Output Connections

2. Channel 2 Output Connector

4-Pin Neutrik Speakon connector provides single-connector, quick-disconnect facilities for Channel 2 on pins 1+ & 1-. Pin 1+ is considered the "hot" terminal while pin 1- is "common".

3. Bridge Output Connector

4-Pin Neutrik Speakon connector provides single-connector, quick-disconnect facilities for the amplifier's Bridge output on pins 1+ & 1-. Both Pins 1+ and 1- are considered "hot" and should not be grounded.

4. Channel 1 (and 2) Output Connector

4-Pin Neutrik Speakon connector provides single-connector, quick-disconnect facilities for both Channel 1 and Channel 2 outputs. The Channel 1 output is on pins 1+ & 1- and the Channel 2 output on pins 2+ & 2-. Pins 1+ & 2+ are considered "hot" while pins 1- & 2- are "common".

Note: If your amplifier has a C12 or C22 controller module or L20 limiter module, instead of the standard input module shown in the above drawing, please turn to pages 10 and 11.

Standard Input Module

Output Mode Selector

5. Stereo - Parallel - Bridge Output Mode Selector

The Output Mode Selector allows the amplifier to be operated in 3 different output modes.

In the Stereo mode, the two channels operate independently, just as they do in a stereo amplifier: signals fed into the two amplifier inputs are amplified separately and delivered in phase to outputs 1 & 2. The output levels are controlled separately by the front panel mounted attenuators.

In the Parallel mode, input 2 is disabled and the two amplifier channels operate in parallel from a single input signal fed into the Channel 1 input. This eliminates the need to install a jumper cable to operate the amplifier channels in parallel. The outputs are separate and in phase and both input attenuators are active to permit different level settings for each channel.

In the Bridge mode, a single signal is fed into the Channel 1 input which drives both output channels in tandem. The output is delivered to the Bridge Output connector. This mode allows

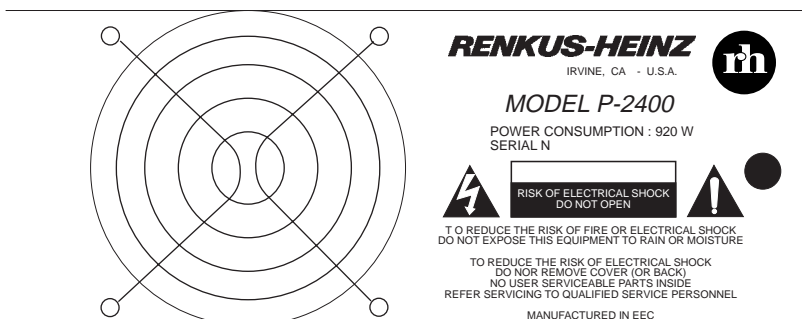

the two amplifier outputs to be strapped together ("bridged") to produce a single output with double the power capabilities of a single channel. Input #2 is disabled. Both input attenuators are active and must be set to the same level. Note that in bridge mode both sides of the output should be considered hot and should not be grounded.

6. Channel 2 Audio Input Connector

Female 3-pin XLR type input connector for Channel 2. The input is electronically balanced. We recommend the use of pin 2 as "hot" and pin 3 as "neutral". Pin 1 is chassis ground. When the amplifier is connected to a balanced source, the shield may either be lifted or connected at the source end. The choice should be made on the basis of minimum hum.

With an unbalanced source, connect the signal to pin 2 and source ground to pin 3 (connecting the signal to pin 3 is not recommended as this will cause a 180 phase inversion at the amplifier outputs. *Note: Improper operation results when only pin 2 or only pin 3 and pin 1 (ground) are used for an unbalanced input.*

7. Channel 2 "Looping Output" Connector

Male 3-pin XLR type "looping output" connector for Channel 2 used to "loop through" to additional amplifiers.

8. Channel 1 "Looping Output" Connector

Male 3-pin XLR type "looping output" connector for Channel 1 used to "loop through" to additional amplifiers.

9. Channel 1 Audio Input Connector.

Female 3-pin XLR type input connector for Channel 1. Refer to 6 above for details.

10. Ground Lift Switch.

The Ground Lift switch is used to separate the signal ground circuit from the amplifier ground circuit and thus, eliminate hum induced by ground loops.

In the left "ON" position, the signal ground is electrically disconnected from the amplifier ground circuit (the chassis).

In the center "OFF" position, the input signal ground is electrically connected to the amplifier ground circuit (the chassis).

In the right "ON" position, an AC connection is provided between the signal ground and the amplifier ground circuit (the chassis).

Input Connections

"Looping" Outputs

Ground Lift Switch

Loudspeaker Controller Modules

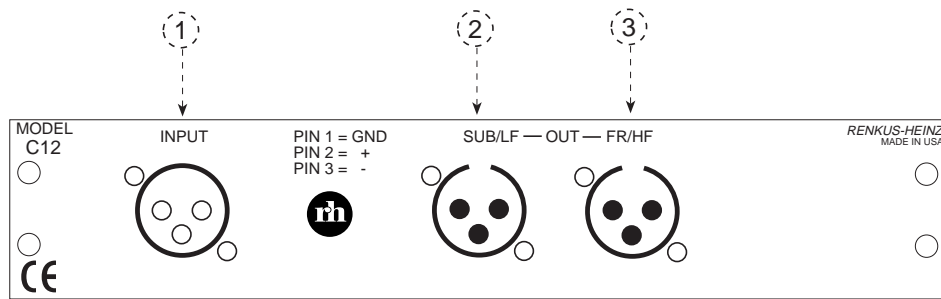

C12 Controller Module

The C12 loudspeaker controller module is a single input, dual output controller designed for use with active 2-way loudspeakers (or 3-way loudspeakers set up for bi-amp operation) in single channel (mono) systems. In this application, it provides crossover, protection and response shaping. It is also often used as a controller to provide protection and response shaping for either subwoofers or passive 2-way loudspeakers.

Input Connections

1. Audio Input Connector

Female 3-pin XLR type input connector. The input is electronically balanced. We recommend the use of pin 2 as "hot" and pin 3 as "neutral". Pin 1 is chassis ground. When the amplifier is connected to a balanced source, the shield may either be lifted or connected at the source end. The choice should be made on the basis of minimum hum.

With an unbalanced source, connect the signal to pin 2 and source ground to pin 3 (connecting the signal to pin 3 is not recommended as this will cause a 180 phase inversion at the amplifier outputs). *Note: Improper operation results when only pin 2 or only pin 3 and pin 1 (ground) are used for an unbalanced input.*

Output Connections

2. SUB/LF "Output" Connector

Male 3-pin XLR type controller output connector for the SUB/LF channel; used to drive additional amplifiers.

3. FR/HF "Output" Connector

Male 3-pin XLR type controller output connector for the FR/HF channel; used to drive additional amplifiers.

Note: When the processed controller outputs are used to drive additional amplifiers, it is imperative that the source amplifier's level controls are set at the same or a higher level. Otherwise, the protection feature is lost for the other amplifiers.

C22 Controller Module

The C22 loudspeaker controller module is a dual input, dual output controller designed for use in stereo systems having either passive loudspeakers or subwoofers. In these systems, it provides protection for the loudspeakers or subs, as well as high & low pass filters and response shaping.

Output Connections

1. Channel 2 "Processed Output" Connector

Male 3-pin XLR type controller "processed output" connector for Channel 2; provides a "looping" controller processed output for use in driving additional amplifiers.

3. Channel 2 "FR/HPF Output" Connector

Male 3-pin XLR type controller output connector for the FR/HPF channel; used to drive additional amplifiers. An internal selector switch determines whether this connector provides a full-

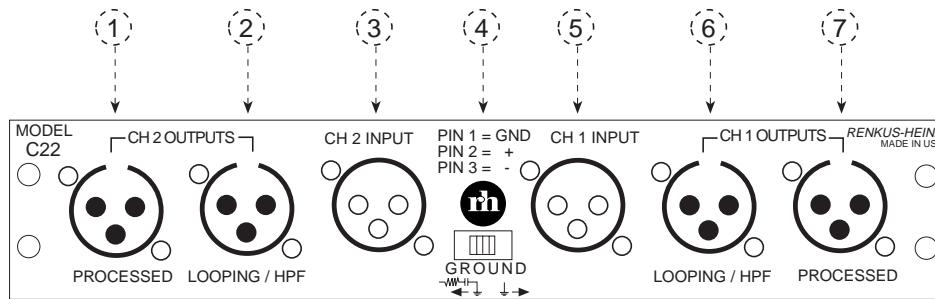

range "looping" output or a processed band-limited "high pass filter" output. Refer to Selector Switches on page 12 for further information.

3. Channel 2 Audio Input Connector

Female 3-pin XLR type input connector. The input is electronically balanced. We recommend the use of pin 2 as "hot" and pin 3 as "neutral". Pin 1 is chassis ground. When the amplifier is connected to a balanced source, the shield may either be lifted or connected at the source end. The choice should be made on the basis of minimum hum.

With an unbalanced source, connect the signal to pin 2 and source ground to pin 3 (connecting the signal to pin 3 is not recommended as this will cause a 180 phase inversion at the amplifier outputs). *Note: Improper operation results when only pin 2 or only pin 3 and pin 1 (ground) are used for an unbalanced input.*

4. Ground Lift Switch.

The Ground Lift switch is used to separate the signal ground circuit from the amplifier ground circuit and thus, eliminate hum induced by ground loops.

In the right position, the input signal ground is electrically connected to the amplifier ground circuit (the chassis).

In the left position, only an AC connection is provided between the signal ground and the amplifier ground circuit (the chassis).

5. Channel 1 Audio Input Connector.

Female 3-pin XLR type input connector for Channel 1. Refer to 3 above for details.

6. Channel 1 "FR/HPF Output" Connector

Male 3-pin XLR type controller output connector for the FR/HPF channel; used to drive additional amplifiers. An internal selector switch determines whether this connector provides a full-range "looping" output or a processed band-limited "high pass filter" output. Refer to Selector Switches on page 12 for further information.

7. Channel 1 "Processed Output" Connector

Male 3-pin XLR type controller "processed output" connector for Channel 2; provides a "looping" controller processed output for use in driving additional amplifiers.

Note: When the processed controller outputs are used to drive additional amplifiers, it is imperative that the source amplifier's level controls are set at the same or a higher level. Otherwise, the protection feature is lost for the other amplifiers.

**Input
Connections**

**Ground Lift
Switch**

**Input
Connections**

**Output
Connections**

Loudspeaker Controller Modules

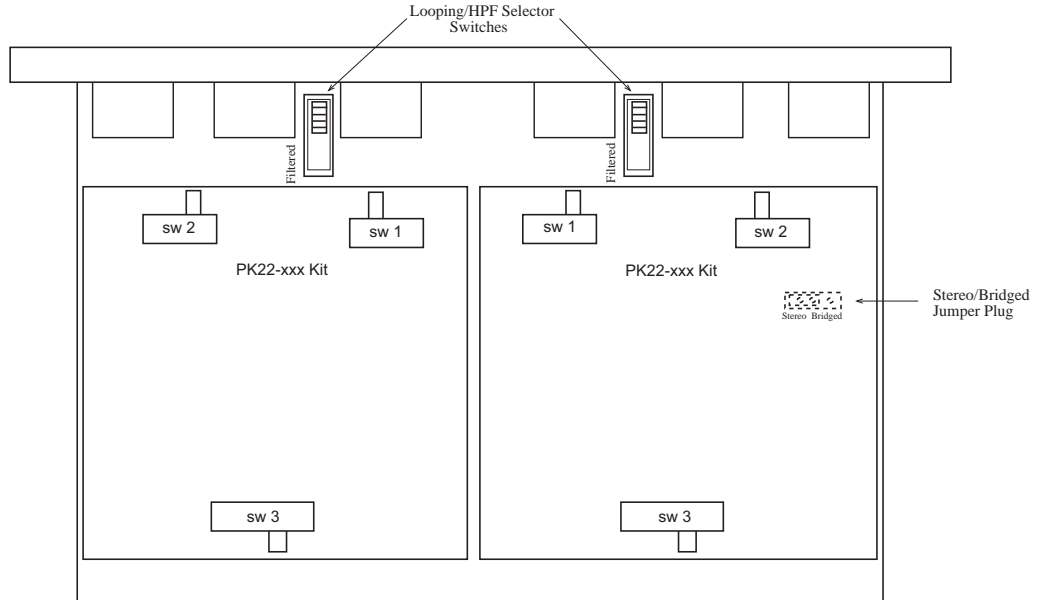

C22 Controller Module Physical Layout

C22 Setup Switches

The C22 Loudspeaker Controller Module has several selector switches and a Stereo/Bridging Jumper plug that are accessible by removing the module from the amplifier. The location of these controls is shown in the above outline drawing.

The Looping/HPF switches control the signals to the Looping/HPF output connectors. In the Filtered position, the associated output connector is connected to the output of that channel's high pass filter. In the other position, the connector parallels that channel's input connector and serves as a "looping" output. The HPF setting is used to deliver a band-limited signal to an additional amplifier for "non-overlap" operation (refer to the system wiring diagram on page 16 for further information).

The Stereo/Bridging Jumper plug is used to "bridge" the two output channels together to provide a single output with twice the power capabilities of a single channel. Note that the Jumper Plug is located under the right PK22-xxx kit, which must be removed (unplugged) to gain access to the Jumper Plug.

The switches identified as sw 1, sw 2 and sw 3 are used to configure the C22 for specific loudspeakers. Additional information on these switches can be found in the C22 Operation Manual.

L20 Limiter Module

The L20 is a dual-channel limiter module. It is not loudspeaker specific and is provided with user adjustable limit and HPF (high pass filter) controls (refer to drawing on next page). It is used to provide limiting on both amplifier channels (loudspeaker protection) plus low frequency rolloff.

Looping Outputs

1 & 6. "Looping" Audio Output Connectors

These male 3-pin XLR type connectors are wired in parallel with the input connectors and provide unprocessed "looping" Channels 1 and 2 outputs. They allow "looping" through to additional amplifiers.

HPF Selectors

2 & 5. HPF Selector Switches

Three position switches allow the Channel 1 and 2 low frequency rolloff points to be set at either 30 Hz, 60 Hz or 100 Hz to protect small loudspeakers from over excursion damage.

Loudspeaker Controller Modules

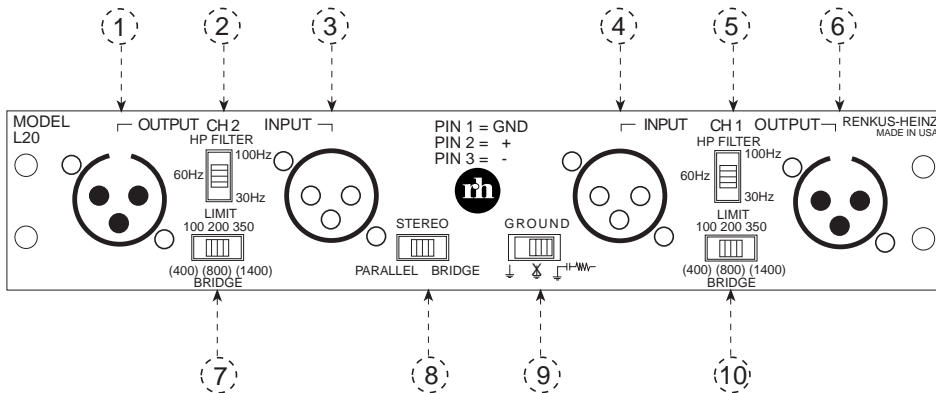

3 & 4. Audio Input Connectors

Female 3-pin XLR type input connectors for Channels 1 and 2. Refer to section 6 on page 9 for wiring details.

7 & 10. Limit Set Switches

Three position switches allow the Channel 1 and 2 maximum output levels to be set at either 100, 200 or 350 watts into 8 ohms (400, 800 or 1400 watts in bridge mode).

8. Stereo - Parallel - Bridge Output Mode Selector

The Output Mode Selector allows the amplifier to be operated in 3 different output modes.

In the Stereo mode, the two channels operate independently, just as they do in a stereo amplifier: signals fed into the two amplifier inputs are amplified separately and delivered in phase to outputs 1 & 2. The output levels are controlled separately by the front panel mounted attenuators.

In the Parallel mode, input 2 is disabled and the two amplifier channels operate in parallel from a single input signal fed into the Channel 1 input. This eliminates the need to install a jumper cable to operate the amplifier channels in parallel. The outputs are separate and in phase and both input attenuators are active to permit different level settings for each channel.

In the Bridge mode, a single signal fed into the Channel 1 input, drives both output channels in tandem and the output is delivered to the Bridge Output connector. This mode allows the two amplifier outputs to be strapped together ("bridged") to produce a single output with double the power capabilities of a single channel. Input #2 is disabled. Both input attenuators are active and must be set to the same level. Note that in bridge mode both sides of the output should be considered hot and should not be grounded and that the Limit and HPF switches should be set in the same position.

9. Ground Lift Switch.

The Ground Lift switch is used to separate the signal ground circuit from the amplifier ground circuit and thus, eliminate hum induced by ground loops.

In the left position, the signal ground is electrically connected to the amplifier ground circuit (the chassis).

In the center position, the input signal ground is electrically disconnected from the amplifier ground circuit (the chassis).

In the right position, an AC only connection is provided between the signal ground and the amplifier ground circuit (the chassis).

Input Connectors

Limit Set Switches

Output Mode Selector

Ground Lift Switch

Amplifier Setup and Operation

Mounting

The P2400 and P2700 amplifiers are designed to be mounted in standard 19" racks. They have 4 front panel mounting screws. Because of their depth and weight it is imperative that the amplifier be supported at the rear in any portable application.

Cooling

Both amplifiers are fan cooled and it is important that an ample supply of air is provided at the front of the amplifier and a free air exhaust space is provided at the rear of the amplifier. The internal fan provides adequate cooling when the rack has an open back and the front is not obstructed. Closed back racks may need to be pressurized and provided with an exhaust fan to ensure adequate air movement.

Multiple amplifiers may be stacked directly on top of each other. There is no need to separate them with a blank (spacer) panel. Keep in mind that almost all amplifiers radiate a 50/60 Hz magnetic hum field from their power transformers. It is prudent to provide at least one rack-space between any signal processing equipment and the nearest amplifier to reduce the possibility of induced hum.

Wire Size

The size of the speaker wiring needed depends on the length of the cable. We generally recommend the use of 12 AWG for cables up to 30 meters (approximately 100 feet) in length. The following table shows the signal loss in 30 meters of cable driving a 4 ohm load:

Wire Gauge (AWG)	10	12	14	16	18
Signal Loss (dB)	.44	.69	1.07	1.65	2.49

Using higher wattage amplifiers than actually needed is acceptable when controller modules are used as the controller will keep peak power levels within the acceptable limits for the associated loudspeaker(s).

Verification of Proper Operation

Before applying power to the system, trace and verify all connections.

Caution: Operating the System at full level can damage your hearing. Wear ear protectors and do not position yourself in front of the loudspeakers.

Make certain all the Mode selector switches are set in the desired mode and that outputs are properly connected. Loudspeaker damage may occur if, for example, the Sub outputs are connected to the high frequency drivers and not to the Subs!

Set the power amplifier gain controls to their minimum position.

Turn on the power amplifiers and slowly turn the amplifier level controls to their maximum position one at a time. While you are doing this, verify that as the amplifier gain is increased the appropriate response is obtained (i.e. the sub channel is connected to the subwoofers). Moderate level audio should be heard from the loudspeakers.

Gradually increase the signal level while observing the Signal LED's. As the level increases they should begin to flicker red. As the level continues to increase they will be on for longer periods of time. **Do not operate the system at a level where the protection LED's are illuminated continuously.**

If as you are increasing the level, you hear a sudden loss of one channel and see illumination of a red Status LED, this indicates one of the amplifiers protective circuits has been activated. Turn the amplifier off, reduce the gain and then turn the amplifier on again.

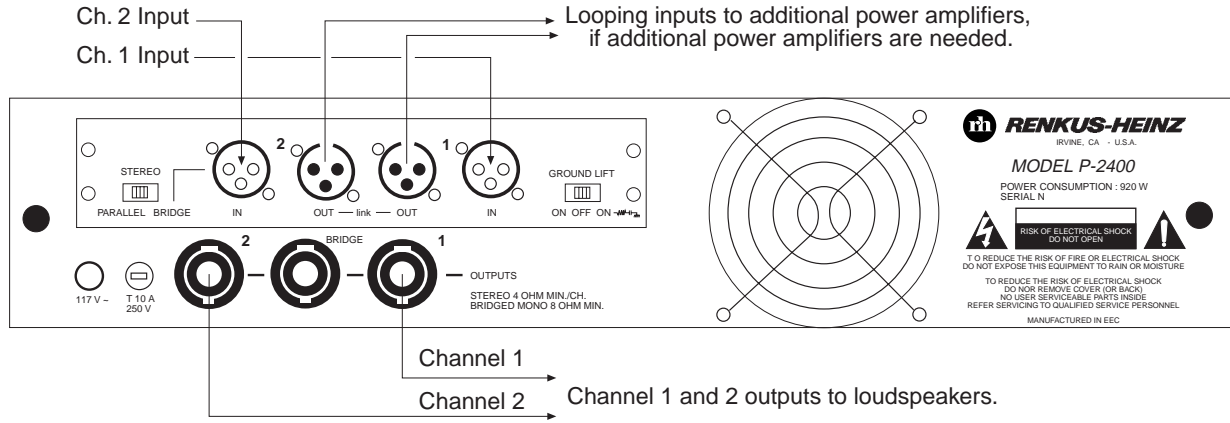

**Typical P2400/2700 system wiring diagram.
(dual channel systems)**

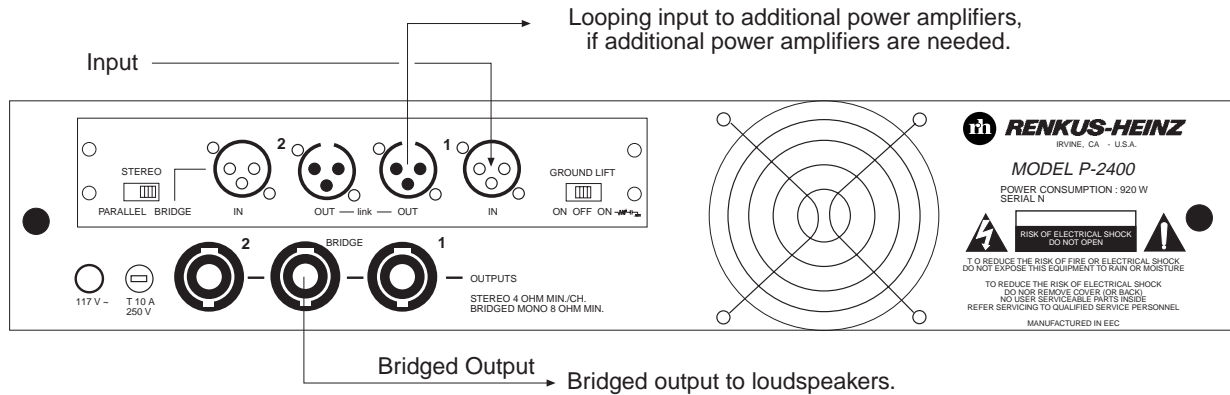

**Typical P2400/2700 system wiring diagram.
(bridged operation)**

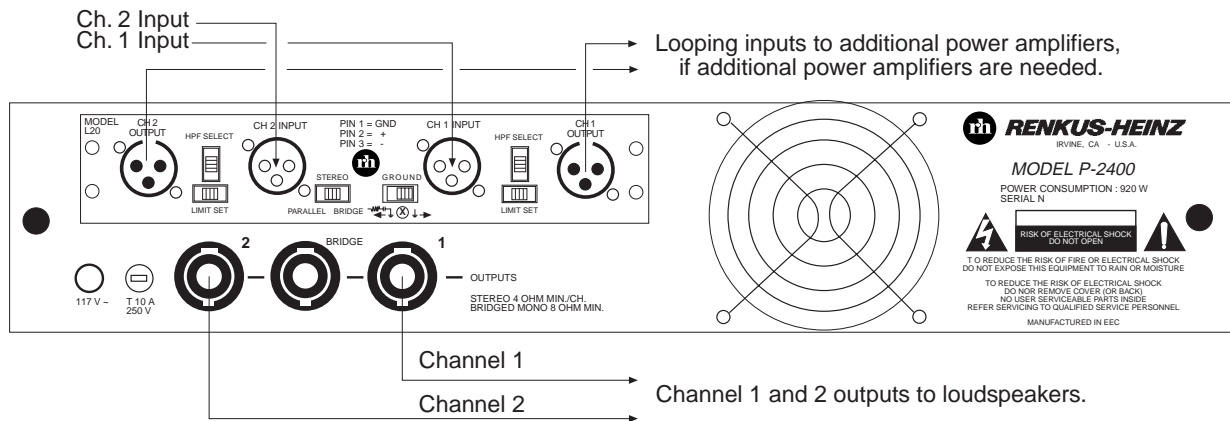

**Typical P2400/2700 with L20 installed system wiring diagram.
(dual channel systems)**

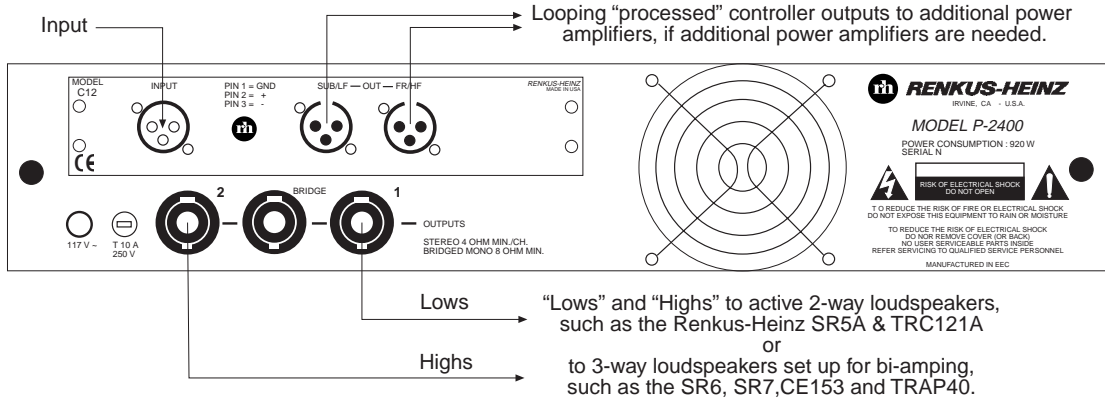

Typical P2400/2700 system wiring diagram with C12 installed. (2-way active loudspeaker systems)

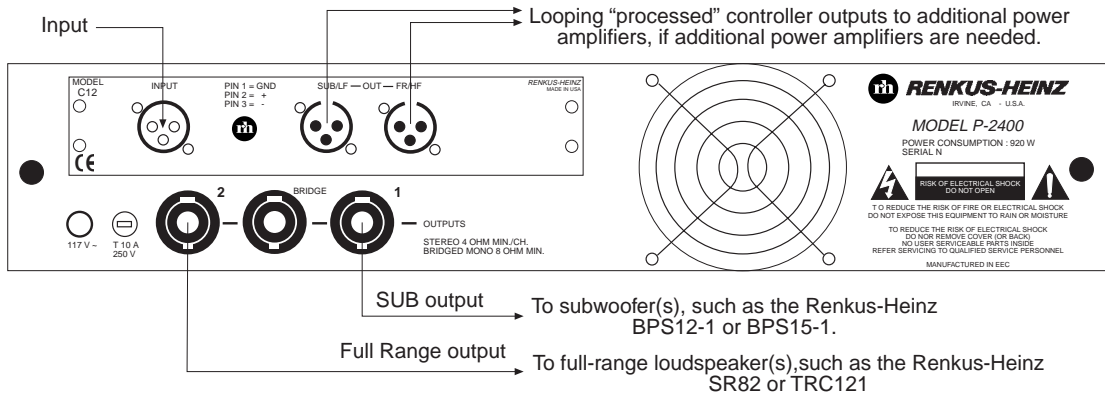

Typical P2400/2700 system wiring diagram with C12 installed. (full range plus sub systems)

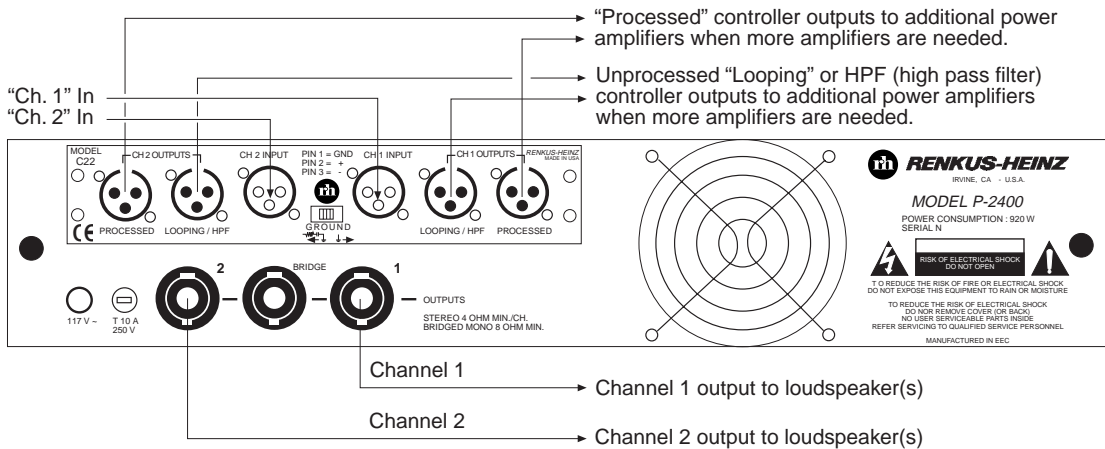

Typical P2400/2700 with C22 installed system wiring diagram. (dual channel systems)