

**RaneNote 108****The SM 26B Swiss Army Mixer**

- **6 In, 2 Out Mixer**
- **2 In, 6 Out Splitter**
- **6 In, 6 Out Buffer Amplifier**
- **4 Channel Stereo Splitter**
- **Other Applications**

**Dennis Bohn**  
**Rane Corporation**

© 1983 Rane Corporation

**INTRODUCTION**

Everyone needs a line level mixer. Even my mother. It has to be small, and cheap, and versatile. It has to be able to mix split, distribute, level match, amplify, attenuate and pan—all without adding any distortion or noise whatsoever. The mind reels.

And recovers, and discovers the Model SM 26B Splitter Mixer from the Rane Corporation. It is small (1 rack space), extremely versatile, and affordable. It is a 6 in/2 out mixer, a 2 in/6 out splitter/distribution amplifier, and a 6 in/6 out buffer amplifier. It has 12dB of gain and better than 80dB of attenuation. The distortion products are less than .009% and the noise floor is a trifle 35 microvolts.

Inside this Rane Note will be found a gruelingly complete description of the innards of an SM 26B and a pathetically skimpy introduction to the many possible applications of same. Such is my belief that you are the best judge of how to apply the SM 26B once you really understand its workings.

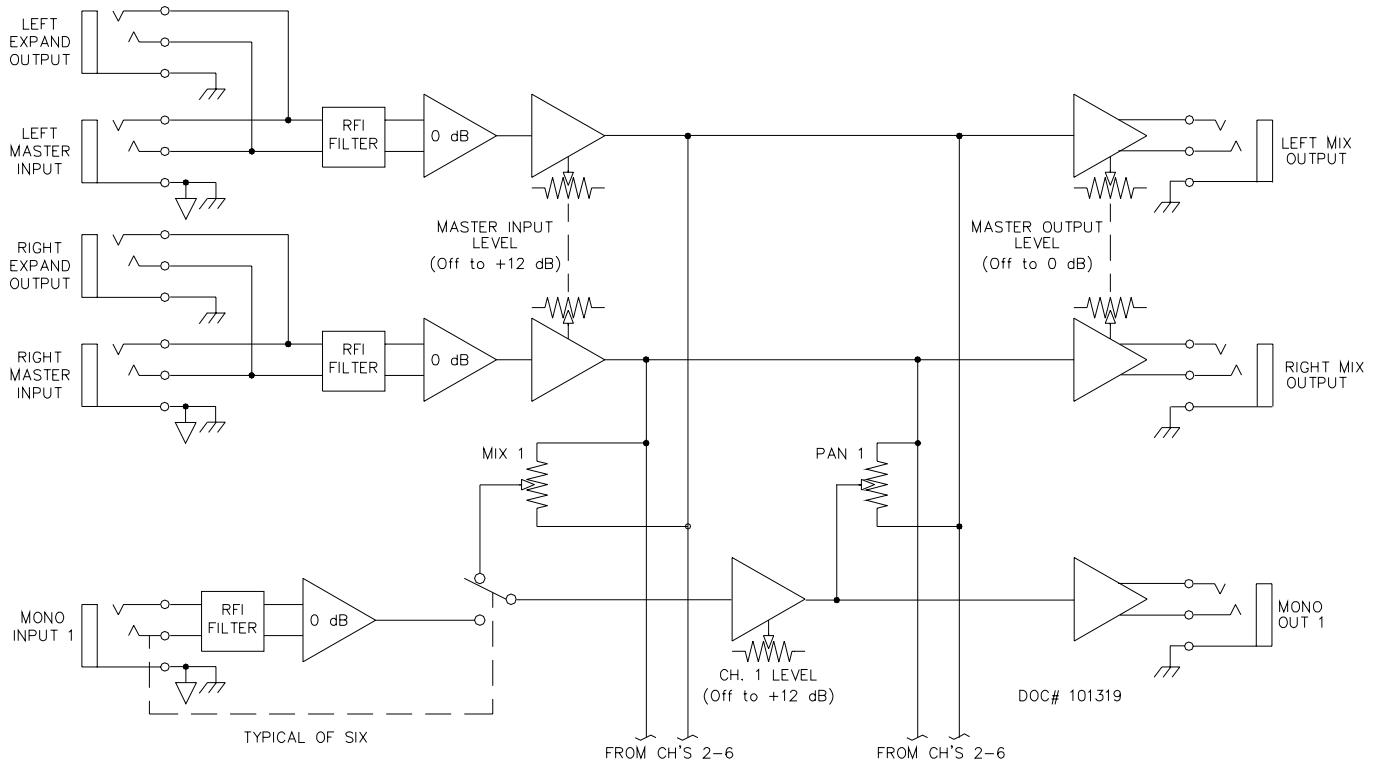

Figure 1. SM 26 Complete Block Diagram

**BLOCK DIAGRAM**

A complete block diagram of the SM 26B appears as Figure 1. (Get your eyeglasses, you may need them.) Stereo input pairs are accommodated by the individual LEFT and RIGHT differential (balanced) INPUT jacks. Expansion or “daisy chaining” is possible through the use of the parallel EXPAND OUT jacks. A dual ganged MASTER INPUT LEVEL control is used to set the gain from off to +12dB for both Inputs.

From here, the Master Inputs feed a left and right mixing bus to each of the six MIX pots, as well as going straight through to the MASTER OUTPUT LEVEL control stage which feeds the Left and Right Mix Output line drivers. The Output from each of the Mix pots feeds the individual Mono Channel Level stages through a switching contact associated with the MONO INPUT jack. (The jacks are drawn in their open, i.e., unused state. Inserting a plug into the MONO INPUT jack causes the auxiliary switch to change position.) The combined left and right signals go to each of the Channel Level Output line drivers.

Individual mono inputs enter through the MONO IN jacks, through the (now closed) auxiliary switch to the +12dB Ch. Level gain stage where it feeds the MONO OUT jack as well as the PAN pot. The PAN pot splits the signal into two signals that feed the LEFT and RIGHT MIX OUTPUTS via the Master Output Level stages.

It’s really quite simple. Now let’s look at specific configurations, leaving out the unused circuitry.

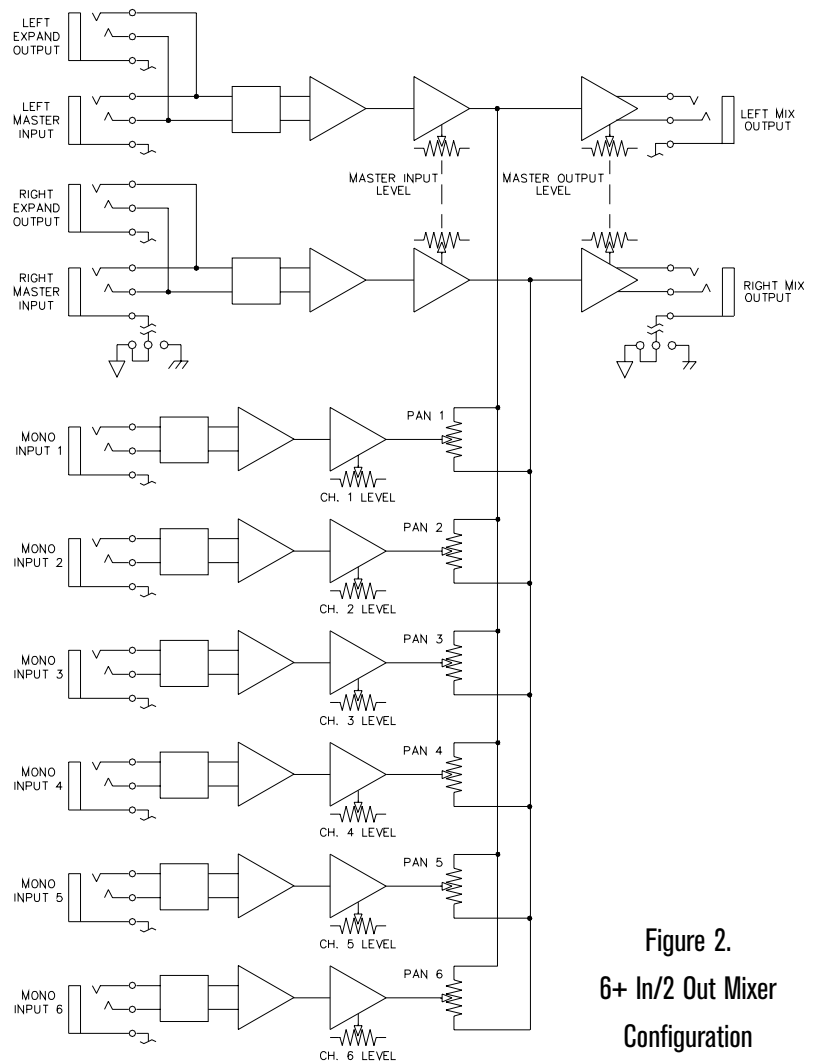

Figure 2.  
6+ In/2 Out Mixer  
Configuration

## 6+ IN/2 OUT MIXER

Figure 2 diagrams the SM 26B signal path when configured as a 6+ In/2 Out mixer. The individual Inputs are connected to each of the six MONO IN jacks and the combined Outputs are taken from the LEFT AND RIGHT MIX OUTPUT Jacks. The “plus” comes from the fact that the LEFT and RIGHT INPUTS also connect to the LEFT and RIGHT MIX OUTPUTS. There is no pan capability on these two Inputs, but each of them does sum with the 6 MONO INs to produce a 6 plus LEFT to the LEFT OUTPUT and a 6 plus RIGHT to the RIGHT OUTPUT option if so desired.

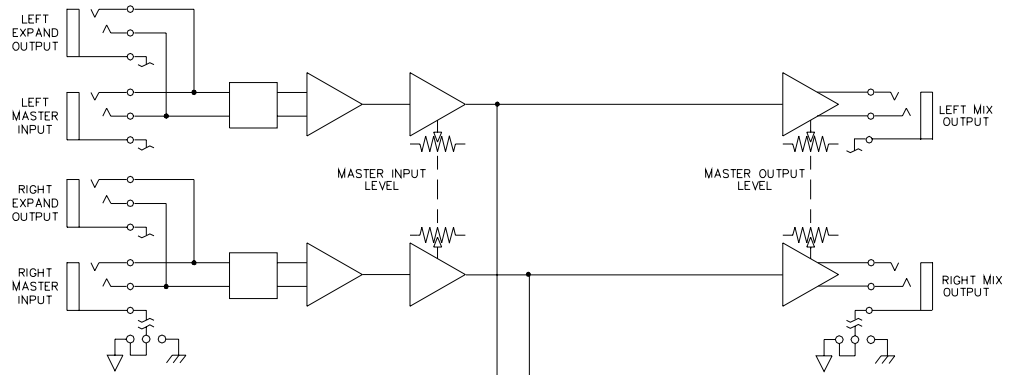

Figure 3. 2 In/6+ Out Splitter/Distribution Amp

## 2 IN/6+ OUT SPLITTER/DISTRIBUTION AMPLIFIER

Figure 3 shows how the SM 26B can be used in the exact opposite mode as described above. When wired per Figure 3, the SM 26B becomes a 2 In/6+ Out splitter/distribution amp. The master stereo signal is connected to the LEFT and RIGHT INPUT jacks and is summed via the six MIX pots to each of the MONO OUTPUTS. The “plus” is that the stereo bus is also coupled directly through to the LEFT and RIGHT MIX OUTPUTS. This allows signal translation from -10dBV to +4dBm or other level related conditioning, to be done to the master stereo bus before feeding other equipment.

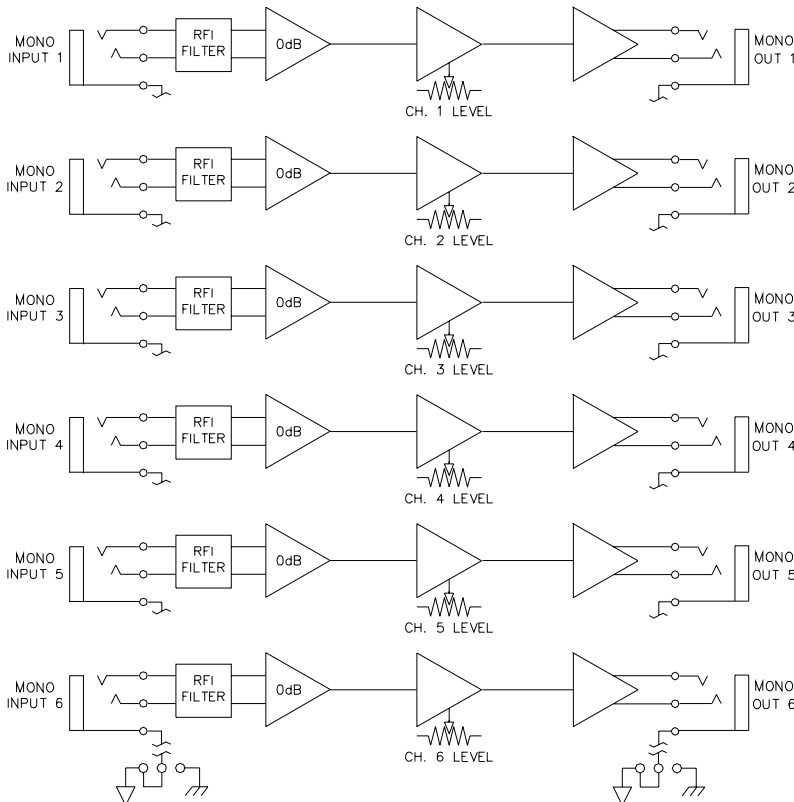

Figure 4. 6 In/6 Out Buffer Amplifier

## 6 IN/6 OUT BUFFER AMPLIFIER

Figure 4 shows how the SM 26B can be used as a “straight through” line buffer amplifier. Inputs are brought into the MONO IN jacks and exit from the MONO OUT jacks. Each CHANNEL has a separate +12dB gain stage with LEVEL control.

*NOTE: One additional channel can be gained by rotating all the PAN pots fully CW and using the LEFT INPUT and LEFT MIX OUTPUT (or rotate fully CCW and use the RIGHT IN and OUT combination).*

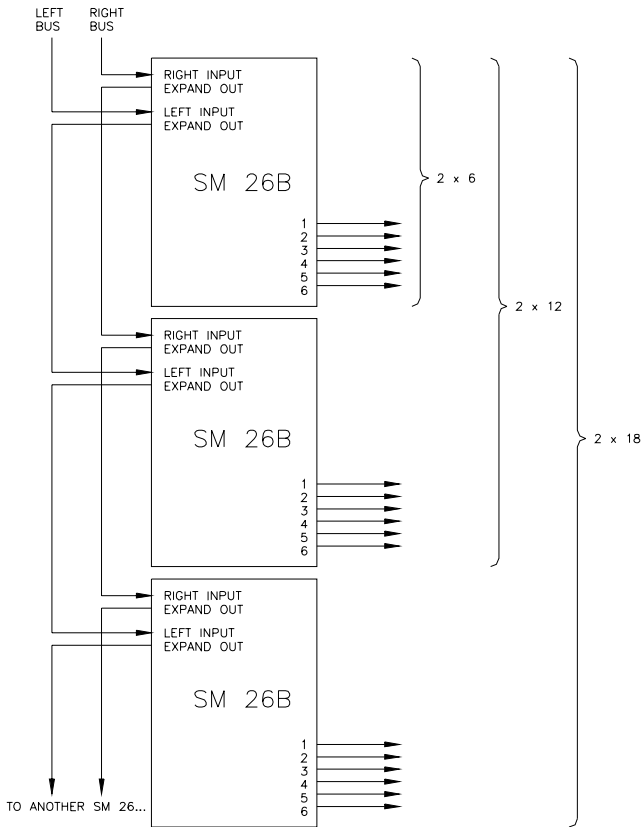

Figure 5. Splitter Expansion

**EXPANSION**

Expanding the input and output capacity of the SM 26B Splitter Mixer is quite easy. Figure 5 shows the procedure for splitter mode expansion. The Left and Right Input buses are “daisy chained” using the EXPAND OUT jacks as shown, and the Outputs are taken directly from each SM 26B's MONO OUTS.

Mixer expansion is the reverse procedure and appears as Figure 6. Inputs are brought into each of the SM 26B's while their respective LEFT and RIGHT MIX OUTPUTS are used to cascade the chain by connecting to the LEFT and RIGHT INPUTS of the next SM 26B, and so on.

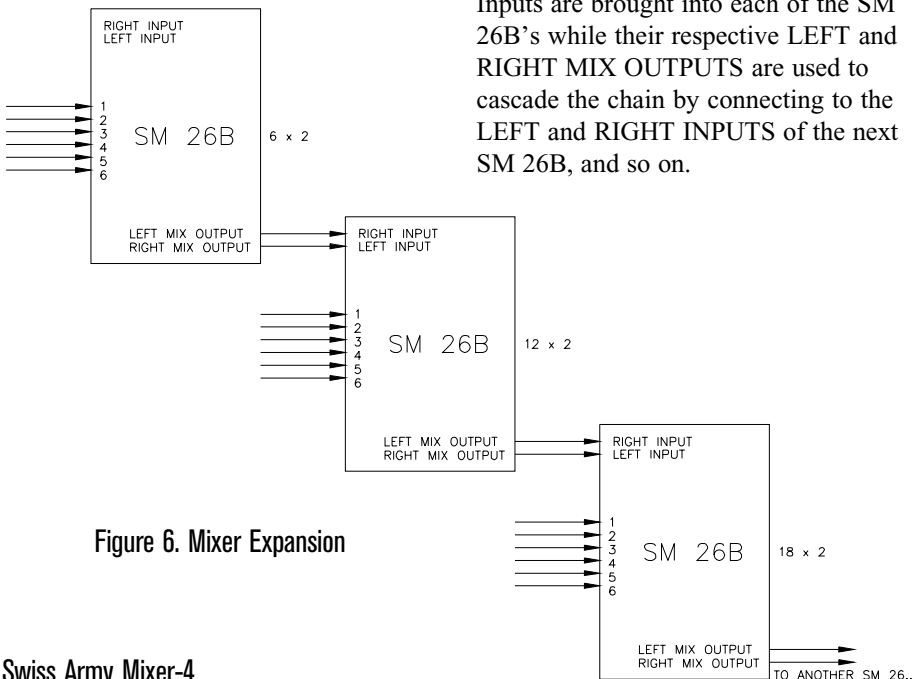

Figure 6. Mixer Expansion

**APPLICATIONS**

The SM 26B is unusually versatile in its applications. With the capability to mix 6 Mono Inputs down to one stereo pair, or split one stereo pair into 6 separate Outputs, or condition 6 Inputs by adding gain or attenuation—all of this either balanced or unbalanced and able to drive 600 ohm lines, makes the SM 26B truly a “Swiss Army Mixer”. Further, any combination of the above can occur at the same time, in the same unit.

**1 IN/3 OUT + 3 IN/3 OUT COMBINATION**

For instance, you can split one signal into three separate Outputs with individual LEVEL controls and use the remaining three MONO INS and OUTS as buffer/line driving amps, creating a 1-to-3/3-to-3 combination.

**6 IN/6+2 OUT**

Another interesting combination is to use the SM 26B as a 6 In/6 Out level translation amplifier (infinite cut to +12dB boost) and also mix the 6 Mono Inputs down to one stereo pair with the PAN pots. The stereo Output appears at the LEFT and RIGHT MIX OUTPUT jacks.

**6+2 IN/2 OUT**

Or bring 6 Mono and 1 Stereo pair into the SM 26B and add the 6 MONO INs to the stereo pair via the PAN pots. You now have a 6+2 In/2 Out situation with the 6 Mono Inputs still available as 6 buffered Outputs if needed.

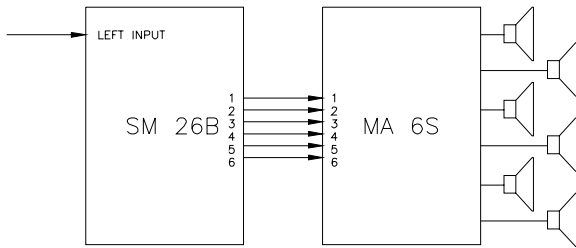

Figure 7. Level Controls for the MAGS Amplifier

**ZONE AMPLIFIER LEVEL CONTROLS**

Adding individual remote level controls to the MA 6S Multichannel Amplifier is easy with the SM 26B as diagrammed in Figure 7. The mono signal is applied to the LEFT INPUT jack and the 6 balanced MONO OUTS are connected to the balanced inputs of the MA 6S. Rotating all MIX pots fully CCW routes the Input signal to each of the MONO OUTS. Each individual Output is adjusted by the respective LEVEL control for that Channel.

If separate sources are connected to the LEFT and RIGHT INPUT jacks then the individual MIX pots will determine which source (or combination of both) is presented to each of the MONO OUTS. Output; full CW rotation gives Right only; and the middle position gives equal amounts of Left plus Right.

**STEREO HEADPHONE MIXER**

Figure 8 shows how the SM 26B can be used as a 6 In/2 Out stereo mixer driving the HC 6 Headphone Console. Six Mono Inputs are brought into the SM 26B where they are mixed together via the PAN pots to create a stereo output signal at the LEFT and RIGHT MIX OUTPUT jacks. These lines are connected to the MASTER LEFT and RIGHT INPUT jacks of the HC 6 where they drive the six stereo headphone amplifiers.

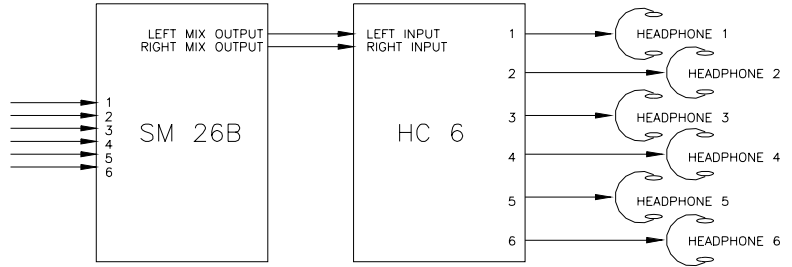

Figure 8. Stereo Headphone Mixer

**4 CHANNEL STEREO SPLITTER**

Don't get into the mind trap of thinking of the SM 26B as only a mono splitter mixer. It can function equally well as a stereo splitter mixer. Figure 10 shows how to configure the SM 26B as a 4 Channel stereo splitter. The stereo Input pair is brought into the LEFT and RIGHT INPUT jacks and then routed via the MIX pots to all of the Outputs. By setting CHANNELS 1, 3 and 5 for full Left mix and channels 2, 4 and 6 for full Right mix, you split the incoming signal into 3 stereo output pairs available from OUTS 1 & 2, 3 & 4, and 5 & 6 respectively. The 4th stereo output pair is taken from the LEFT and RIGHT MIX OUTPUT jacks as shown. (Note: use of the 4th independent stereo output requires an internal jumper modification.)

Stereo mixing is done in the exact opposite manner. Up to 4 stereo pairs are brought into all Inputs by connecting one pair to the LEFT and RIGHT INPUT jacks and the three remaining "lefts" to CHANNELS 1, 3 and 5, and the "rights" to CHANNELS 2, 4 and 6. Now by rotating all odd CHANNEL PAN pots fully CCW(Left) and all even CHANNELS fully CW(Right), you have mixed all 4 pairs down to 1 master pair available at the LEFT and RIGHT MIX OUTPUT jacks.

**6-TO-1-TO-6 MIXER SPLITTER**

Figure 9 shows how to use TWO SM 26B's to create a 6-to-1 mix then a 1-to-6 splitter, to drive the 6 Channels of an MA 6S amplifier. In just 5 rack spaces, this configuration creates a complete 6 channel mixer zone amplifier system.

The controls of the first SM 26B are used to condition and mix the six Mono Input signals while the controls of the second SM 26B are used to set the individual Levels of the six 100W amplifiers of the MA 6S.

A six channel mixer and six 100W amplifiers with level controls—all in less than 9" of rack space. Imagine that!

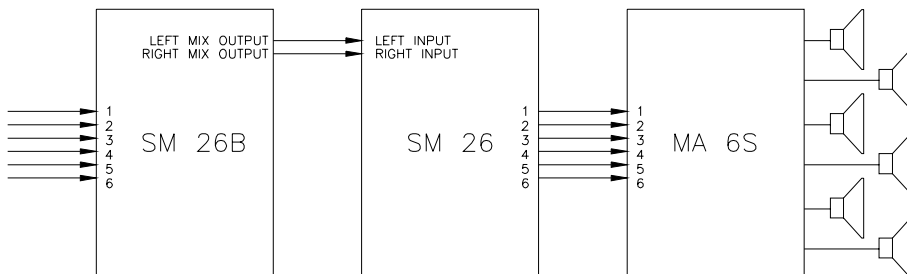

Figure 9. Mixer Splitter

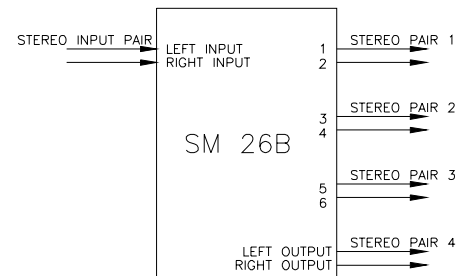

Figure 10. Four Channel Stereo Splitter

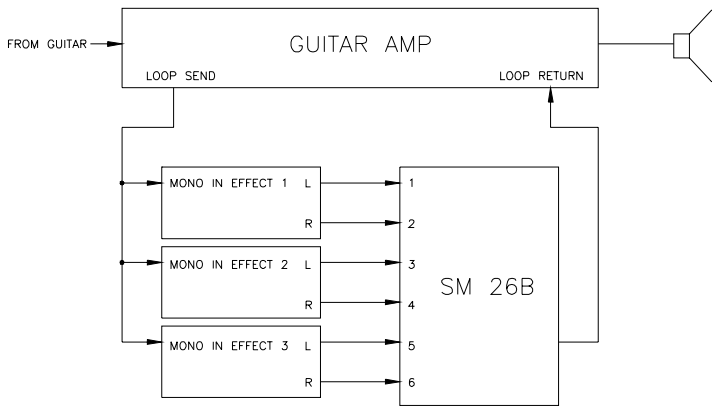

Figure 11. Guitar Effects Mixer

**GUITAR RACKS**

Figures 11-13 show three possible ways to connect a guitar amp to multiple effects. Figure 11 involves buying or building a cable that parallels all of the inputs of the effects so one loop output drives them all. This works and should cause no great difficulty if the output impedance of the amplifier loop is low. Outputs of 1k ohms or less should be able to drive as many effects devices as you would ever want. A second amplifier could be used from the other Mix Output of the SM 26B for stereo.

Many effects have mono inputs and stereo outputs. In this case, connect the left and right outputs of Effect 1 to MONO IN CHANNELS 1 and 2 of the SM 26B respectively. Rotate the MIX/PAN control of CHANNEL 1 all the way to the Left and the MIX/PAN of Channel 2 all the way to the Right. This preserves the mix of the effects' stereo output and passes it to the LEFT & RIGHT MIX OUTPUTS of the SM 26B. Con-

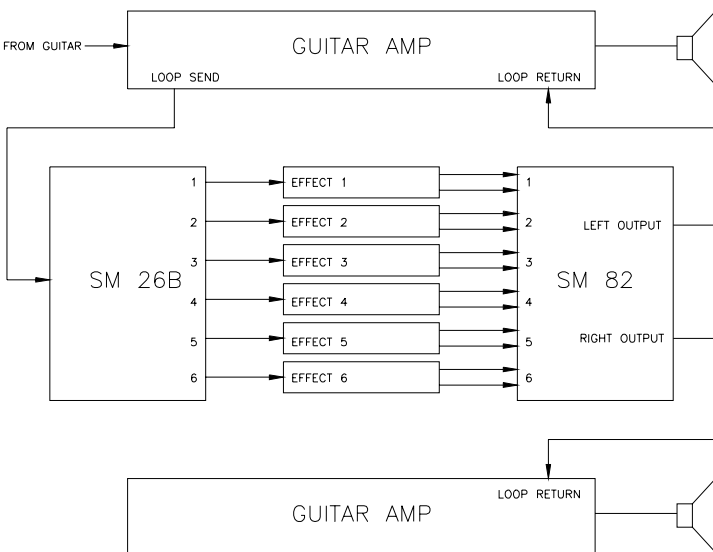

Figure 12. Ultimate Guitar Effects Splitter/Mixer

tinue with Channels 3 & 4 for the second effect and Channels 5 & 6 for the last effect. Set the CHANNEL LEVEL pairs to the same levels to preserve the intended mix of the stereo effect.

The best way, shown in figure 12, uses one SM 26B as a splitter to actively split the signal into as many as six separate feeds (or three stereo) for the effects inputs. To mix all of the effects outputs back together, a second SM 26B connected as a mixer could be enough Inputs for a mono system, or an SM 82 with *eight stereo* Inputs works great for a stereo system.

Now here's a way to *split and mix with one SM 26B*, shown in Figure 13. From the loop output going to the LEFT INPUT, Channels 1,2 and 3 will act as the **splitter**, with their pan controls all the way to the left bus. Since the MONO IN jacks *know* that an individual Input overrides the master Input...Channels 4,5 and 6 will act as the **mixer**, with their pan controls all the way to the right. The RIGHT MIX OUTPUT returns signal to the amplifier. Cool!

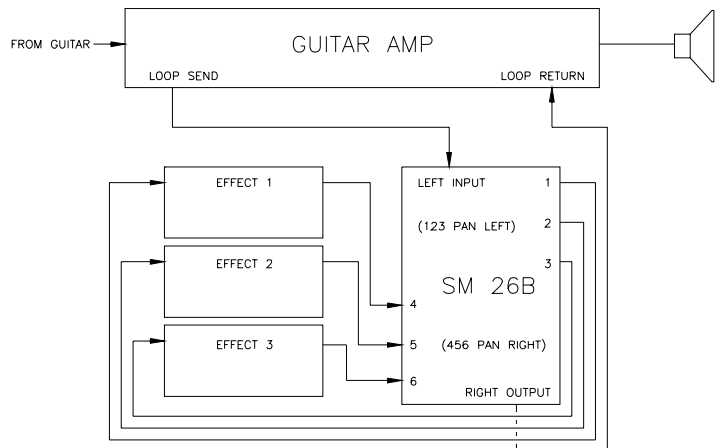

Figure 13. Mono Guitar Effects Splitter/Mixer

**AND MORE**

The range of applications of the Model SM 26B Splitter Mixer is staggering and have been barely touched in the Rane Note. From simple sub-mixing to complex split-mix combinations, to individual equipment signal conditioning, to line splitting, to your unique application, the list of uses for the SM 26B goes on and on.

Experiment and have fun!

Oh, yes. What does my mother need with a line level mixer? She uses it to mix down her drum kit.