

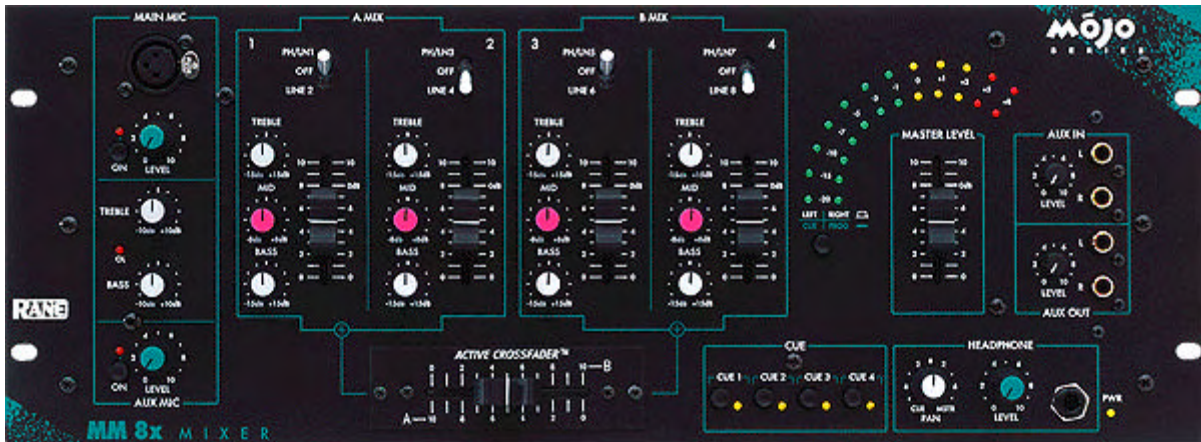

Full Specs!TM **800-356-5844**
Full Compass Xpress Order: 800-476-9886
Mon-Fri 8am-10pm
Sat 10am-6pm Closed Sunday

HOME SALES CATALOG FEEDBACK

Rane **MÓJO** MM8X SERIESTM



Simple Operation Without Compromise in Audio Quality or Dependability

Features:

- Eight stereo inputs with additional front panel aux stereo input and outputs
- Phono inputs are line-level convertible; Separate EQ on each of the four faders
- Front panel extended-life Active Crossfader
- Front and rear panel main and aux mic inputs with EQ and effects loop
- RCA ins; XLR and ¼" mic ins; ¼" loops; RCA tape outs; balanced ¼" TRS outs

Combining the success of the Mojo Series with the MP 22 and MP 24 Mixers, Rane proudly presents the MM 8x Mojo Mixer, the DJ's centerpiece.

The MM 8x features eight stereo Inputs. Each of the four assignable buses contains its own three band EQ, allowing separate equalization of different sources. The four faders are grouped in two pairs, allowing a custom mix of two input sources on each side of the crossfader.

The MM 8x incorporates new Active Crossfader technology that combines state of the art voltage controlled amplifier design with a professional studio quality, dual-rail crossfader control. Combining Active Crossfader technology with a removable crossfader sets new standards for performance, reliability and serviceability. Virtually all crossfader noise is eliminated. Channel to channel crosstalk is greatly reduced and the OFF isolation of the faded channel is greatly increased. Active Crossfader technology dramatically increases the service life of the crossfader. In the unlikely event of crossfader failure, there is no loss of signal. If a crossfader should become rough or noisy, it is possible to 'hot swap' the control during a performance with no interruption of the audio signal. Simply use the input faders to set the audio levels while the crossfader is out of service.

Each of the four Phono (RIAA) Inputs switch to Line Level via rear panel switches.

Both the Main and Aux Mic Inputs route through Bass and Treble controls. The Main Mic input has an Effects Loop. The main program signal includes a stereo Master Loop for equalization or processing.

The Tape Output can be switched to exclude the Master Loop signal and record the unprocessed program signal.

The MM 8x doesn't scrimp on its powerful Headphone Cueing system in which one or more channels may be cued at one time. The metering can be switched to monitor stereo main output or mono cue on one side and mono program on the other.

The MM 8x's recessed top mounted jacks provide room for cabling in tight DJ coffins or racks without sacrificing its compact 4" depth.

LIST PRICE: \$899.00

Call for your best price! 1-800-356-5844



Data Sheet 386 kb



User Manual 659 kb



Schematic 575 kb



How to Order This Item

CLICK

[BACK TO PRODUCTS PAGE](#)

[HOME](#)

[Sales](#)

[Catalog](#)

[Feedback](#)

Prices and specifications are subject to change without notice

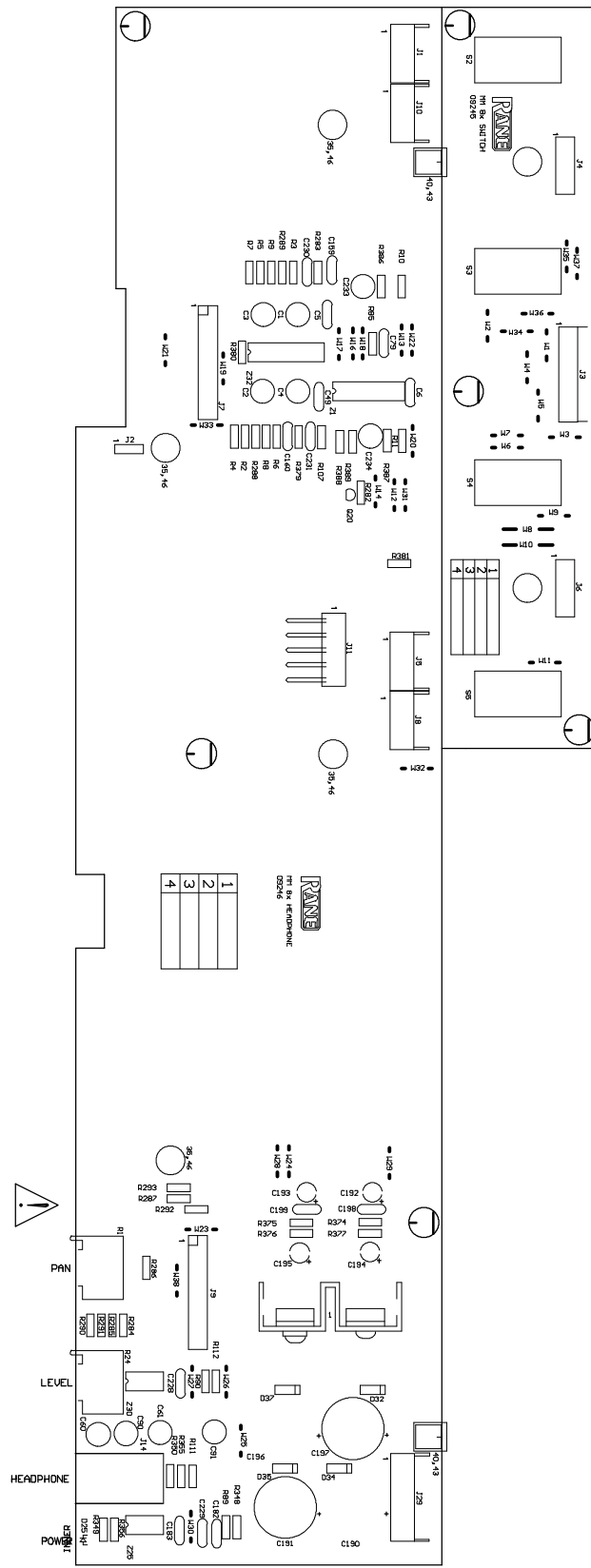

Rane Corp. (425)355-6000
 101798 DES SHEET 1 OF 2 HEADPHONE/SWITCH MM 8X
 ACTION: ADDED ORIENTATION TO J11 RWJ 19MAR98

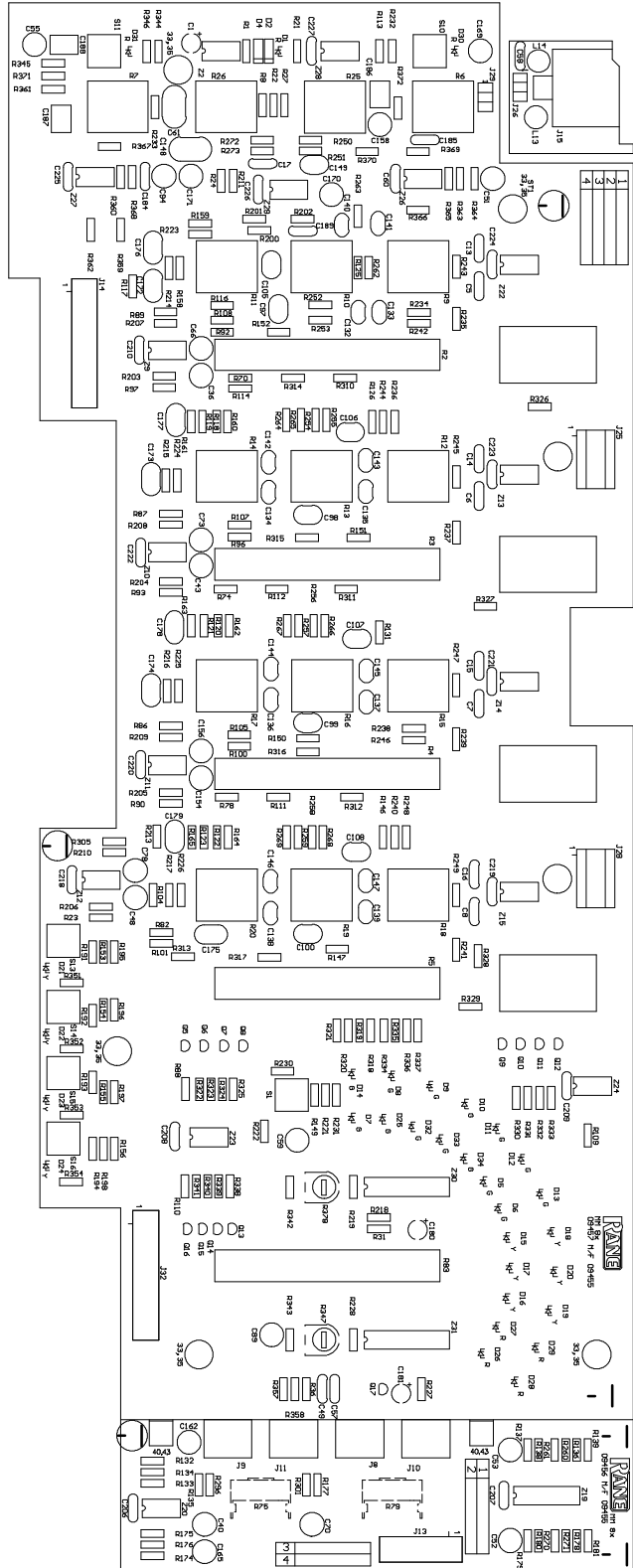
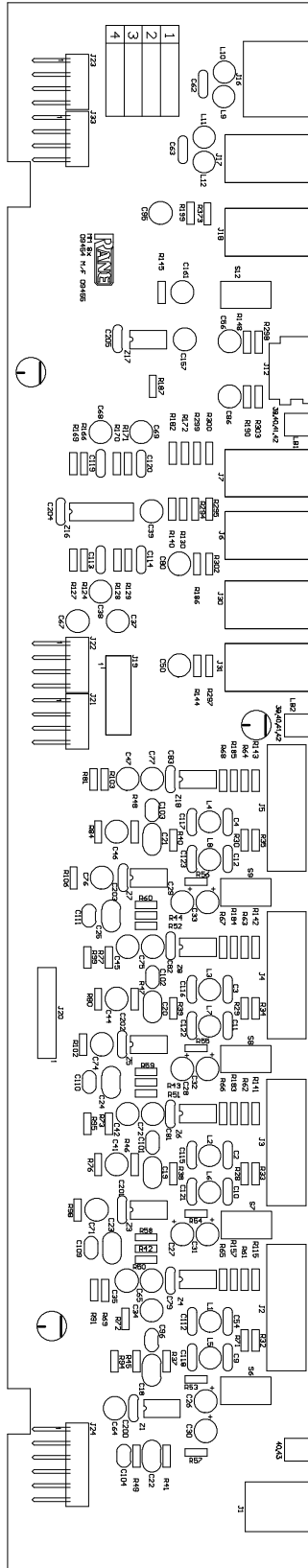

NOTE:
R75 AND R79 ARE TO BE MOUNTED ON CIRCUIT SIDE OF PCB

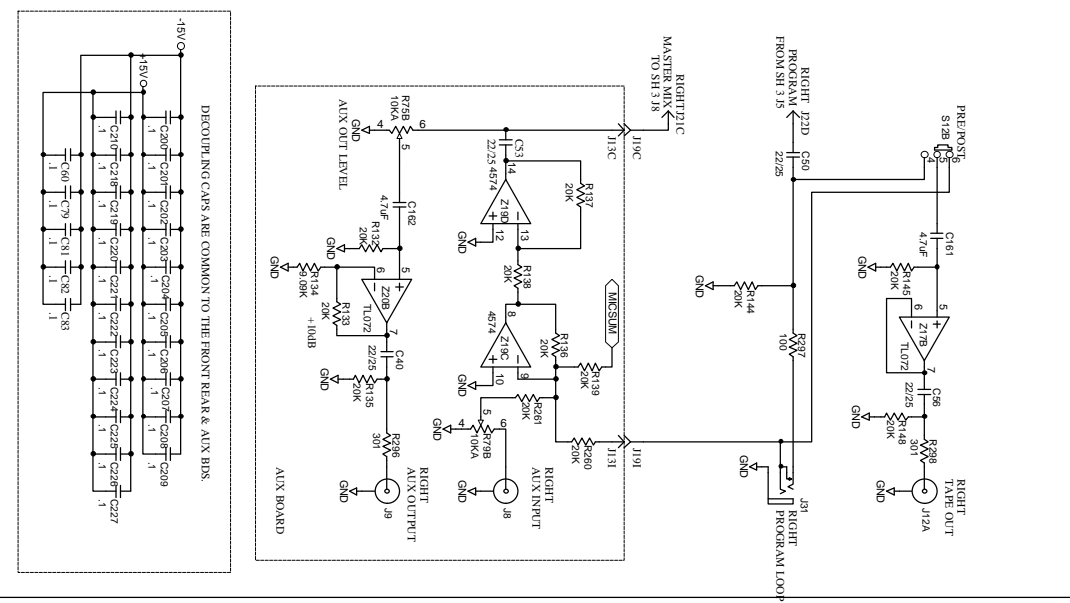
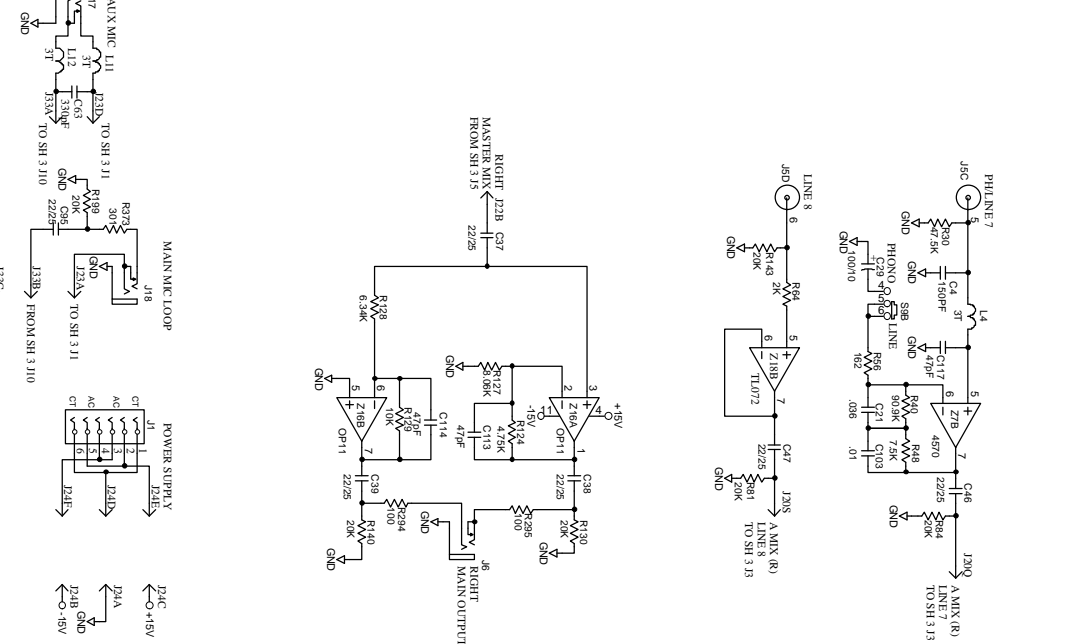
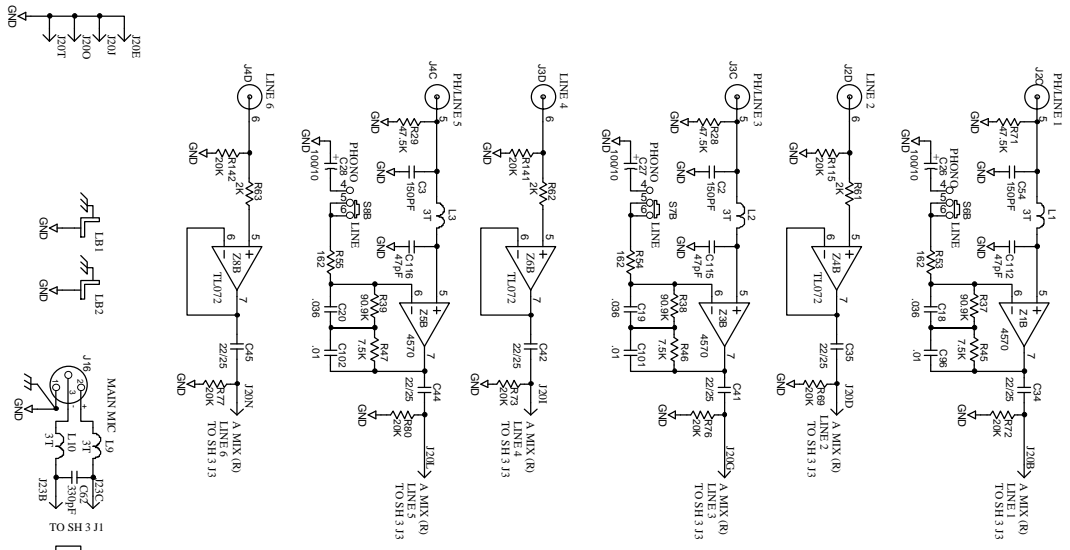

DESIGNED BY:	REVISED BY:	DATE:
19A66-1988		
CHECKED BY:	DATE:	
PANE		
10802-47th Avenue West		
Sheriff		
Makindu V.A. 98275-5088		
MM 8x REAR/AUX RT CH & MISC.		
2 of 5		
101188		

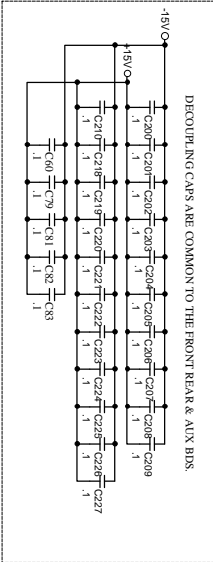

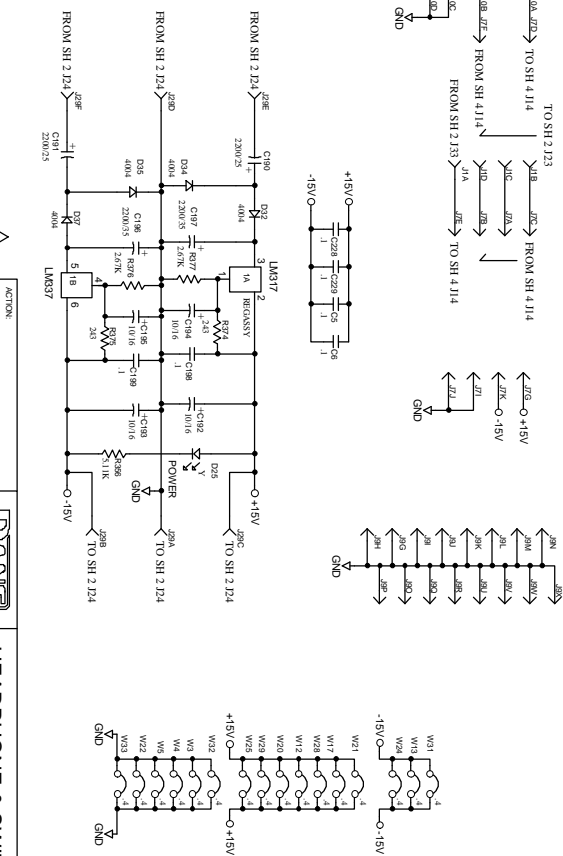
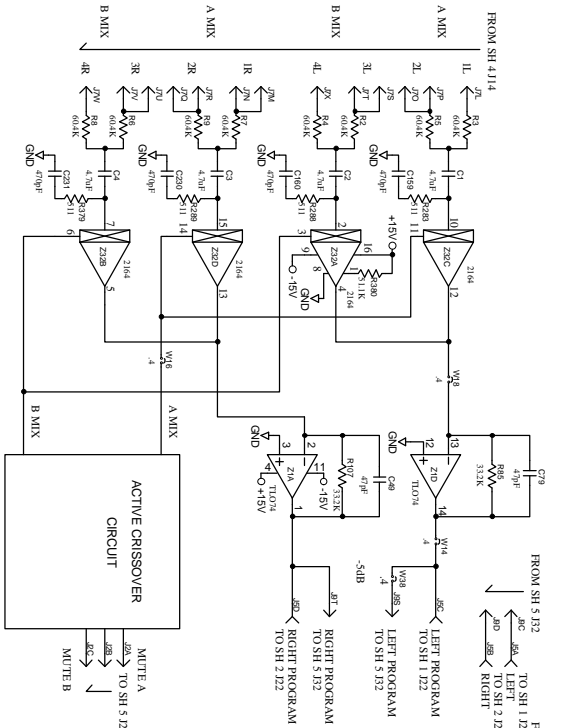
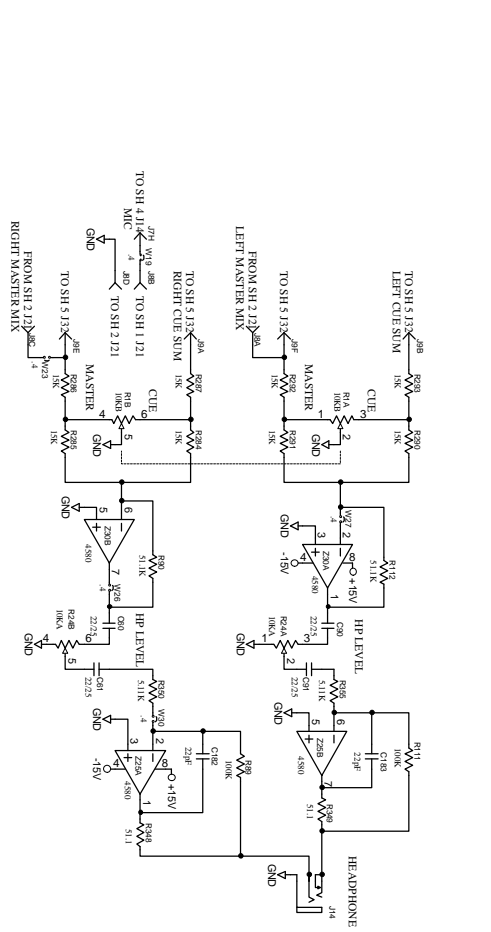
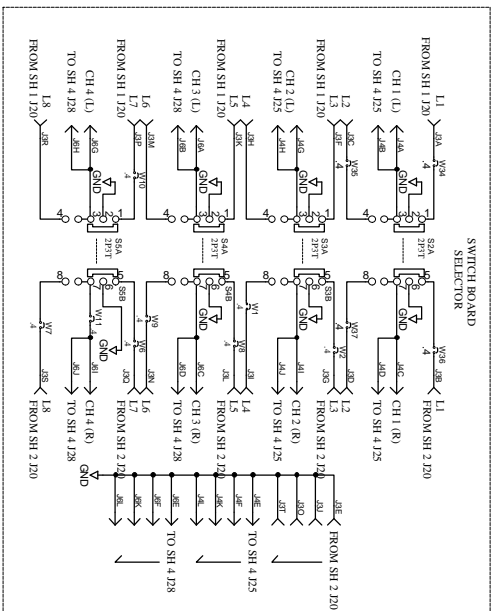

ACTION:	
DESIGNED BY:	RM19
CHECKED BY:	NS



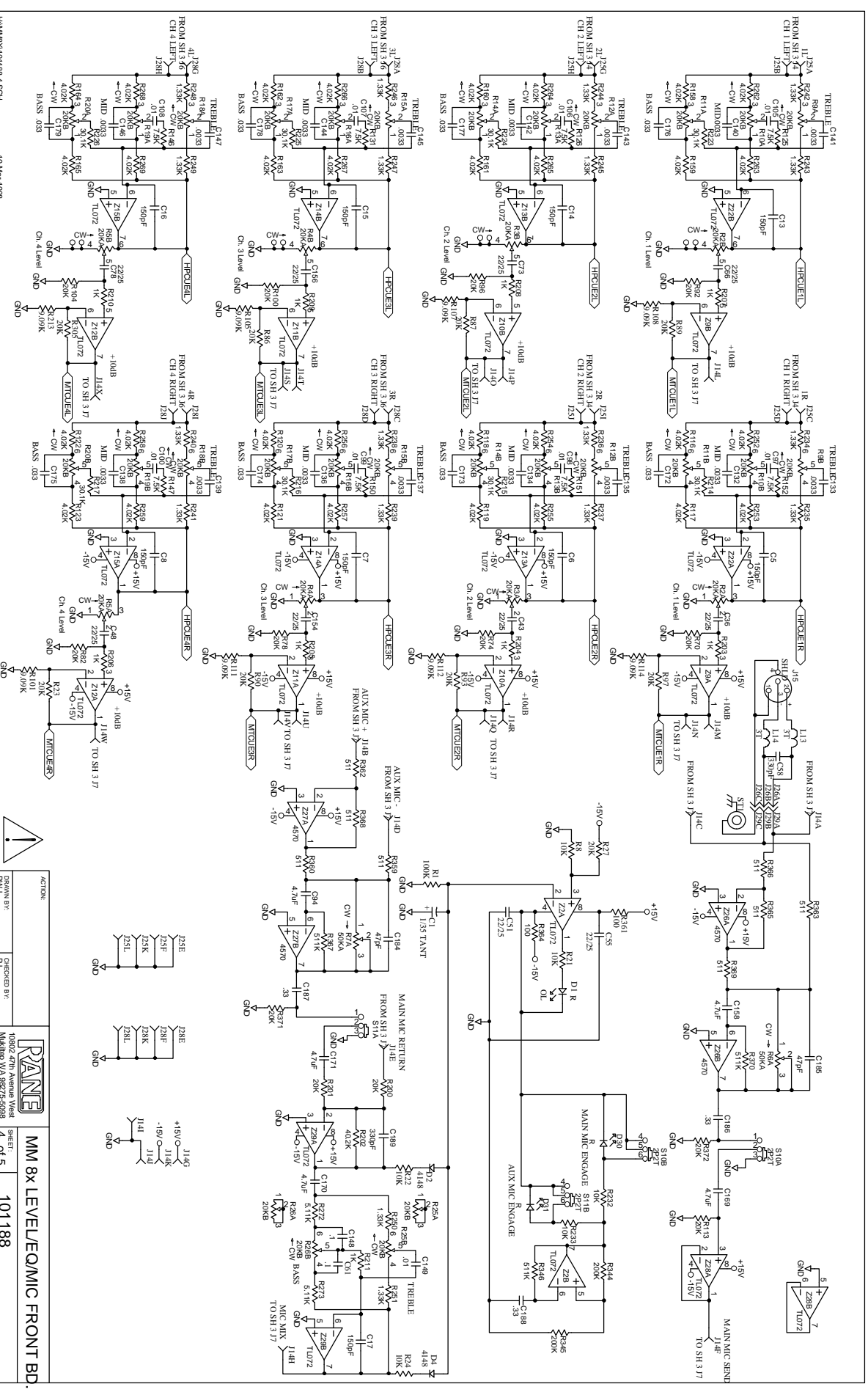

ACTION:	
DESIGNED BY:	RS
CHECKED BY:	RS
PANE	
10892 - 4TH ANNUAL WARR	
Makino V.A. 98275-5088	
MM 8x LEVEL/EQ/MIC FRONT BD.	4 of 5
101188	

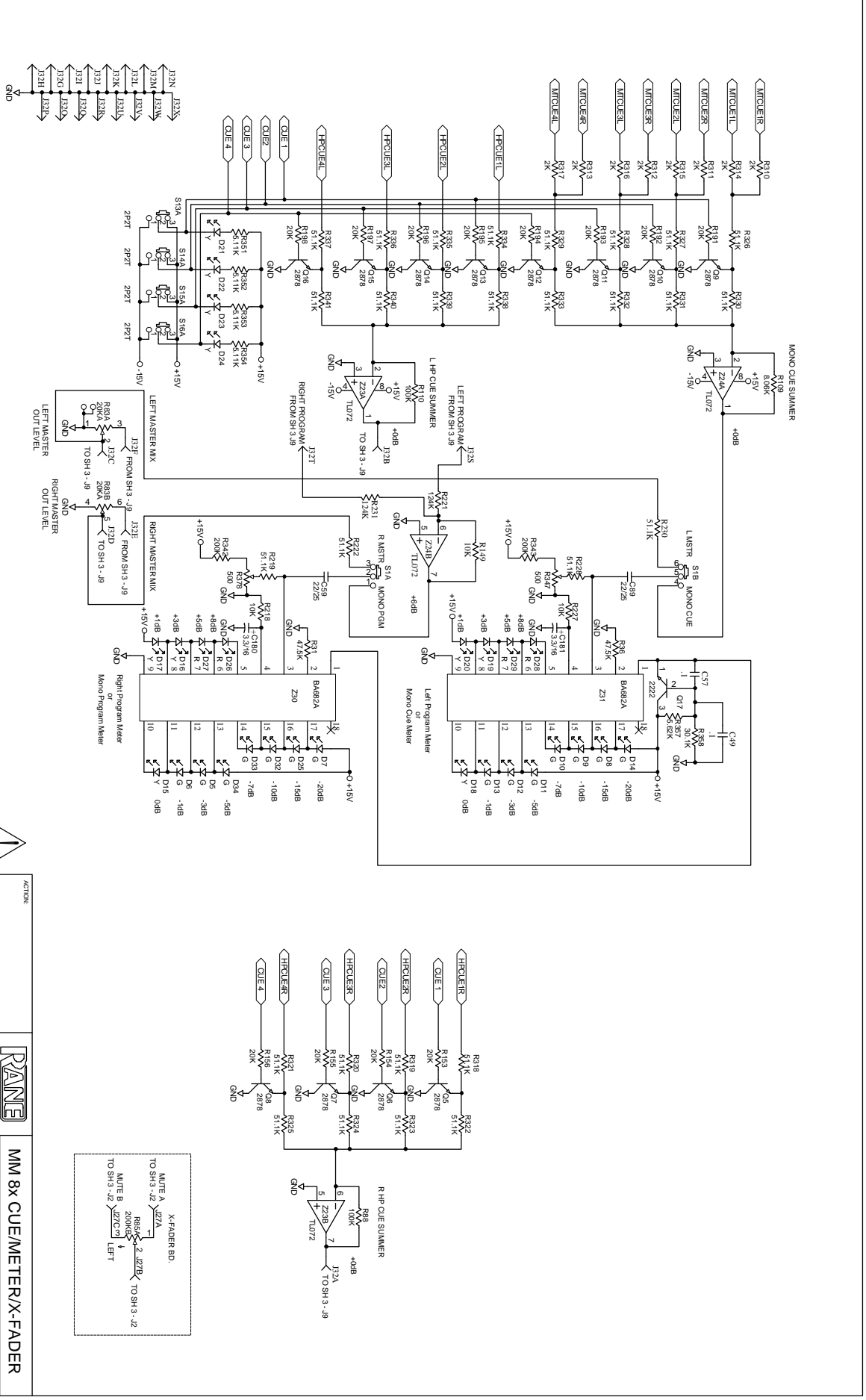

ACTION:		DRAWN BY: R19		CHECKED BY: R9			
		10892-47th Avenue West Mukwonago, WI 53151		MM 8X CUE/METER/X-FADER		SHEET 5 of 5	
				101188			

X-FADER BD.
 MUTE A Z21A TO SH3-J2
 MUTE B Z23C TO SH3-J2
 TO SH3-J2 LEFT