

THIS DOCUMENT CONTAINS PROPRIETARY INFORMATION WHICH IS THE PROPERTY OF QSC AUDIO PRODUCTS, THAT MAY NOT BE DISCLOSED, REPRODUCED OR USED WITHOUT EXPRESS WRITTEN CONSENT FROM QSC AUDIO PRODUCTS.

REVISION				
REV	DESCRIPTION	EFF. DATE	CHK	APPROVED / DATE
1	PROTOTYPE RELEASE SA	9-23-00		
2	CLEAN UP NOTES, ADDED TOLERANCE TO COG PARTS AA	2-21-01		

- 8. ZENER TOLERANCE IS 5%
- 7. SMT CAPACITOR VOLTAGE IS 50V
- 6. SMT RESISTOR WATTAGE RATING IS 0.1W
- 5. RESISTOR WATTAGE RATING IS 1/4W
FOR RESISTOR WATTAGE RATINGS GREATER THAN 1W, TOLERANCE IS 5%
FOR RESISTOR WATTAGE RATINGS LESS THAN 1/2W, TOLERANCE IS 1%
- 4. THROUGH-HOLE FILM AND CERAMIC CAPACITOR TOLERANCE IS 10%, VOLTAGE IS 100V
- 3. ELECTROLYTIC CAPACITOR TOLERANCE IS 20%
- 5. J104, J204 ARE CONNECTED PIN TO PIN BY 13-LINE RIBBON CABLE.
- 4. PART NUMBERING SCHEME
PARTS IN COMMON TO BOTH CH: 1-99. CH 1 PARTS 100-199. CH 2 PARTS 200-299
- 3. COMPONENTS MARKED WITH Δ ARE SAFETY CRITICAL PARTS.
- 2. COMPONENTS WITH VALUE PREFIXED WITH A "*" REPRESENT SMT COMPONENTS.
- 1. THIS DRAWING USED IN CONJUNCTION WITH ASSEMBLY WP-007501-00

NOTES: UNLESS OTHERWISE SPECIFIED

QTY	ITEM NO.	PART NO.	DESCRIPTION	VENDOR
PARTS LIST				
UNLESS OTHERWISE SPECIFIED DIMENSIONS ARE IN INCHES. DIMENSIONS PER ANSI Y14.5-1982 TOLERANCES ARE: DECIMALS DECIMALS ANGLES .xx ± .xxx ± °			CONTRACT NO.	
DEBURR EDGES .XXX R MAX MATERIAL			APPROVALS DATE	
FINISH			DRAWN PAT QUILTER 2-25-00	
NEXT ASSY USED ON			CHECKED	
APPLICATION			ISSUED	
DO NOT SCALE DRAWING			SIZE FSCM NO. DWG NO. REV	
			D SH-008001-00 2	
			SCALE NONE CAD FILE NO. Sh8001r2.sch SHEET 1 OF 4	
			PLOT DATE: 1	
			Mon Mar 19, 2001	

1 SH-008001-00

THIS DOCUMENT CONTAINS PROPRIETARY INFORMATION WHICH IS THE PROPERTY OF QSC AUDIO PRODUCTS, THAT MAY NOT BE DISCLOSED, REPRODUCED OR USED WITHOUT EXPRESS WRITTEN CONSENT FROM QSC AUDIO PRODUCTS.

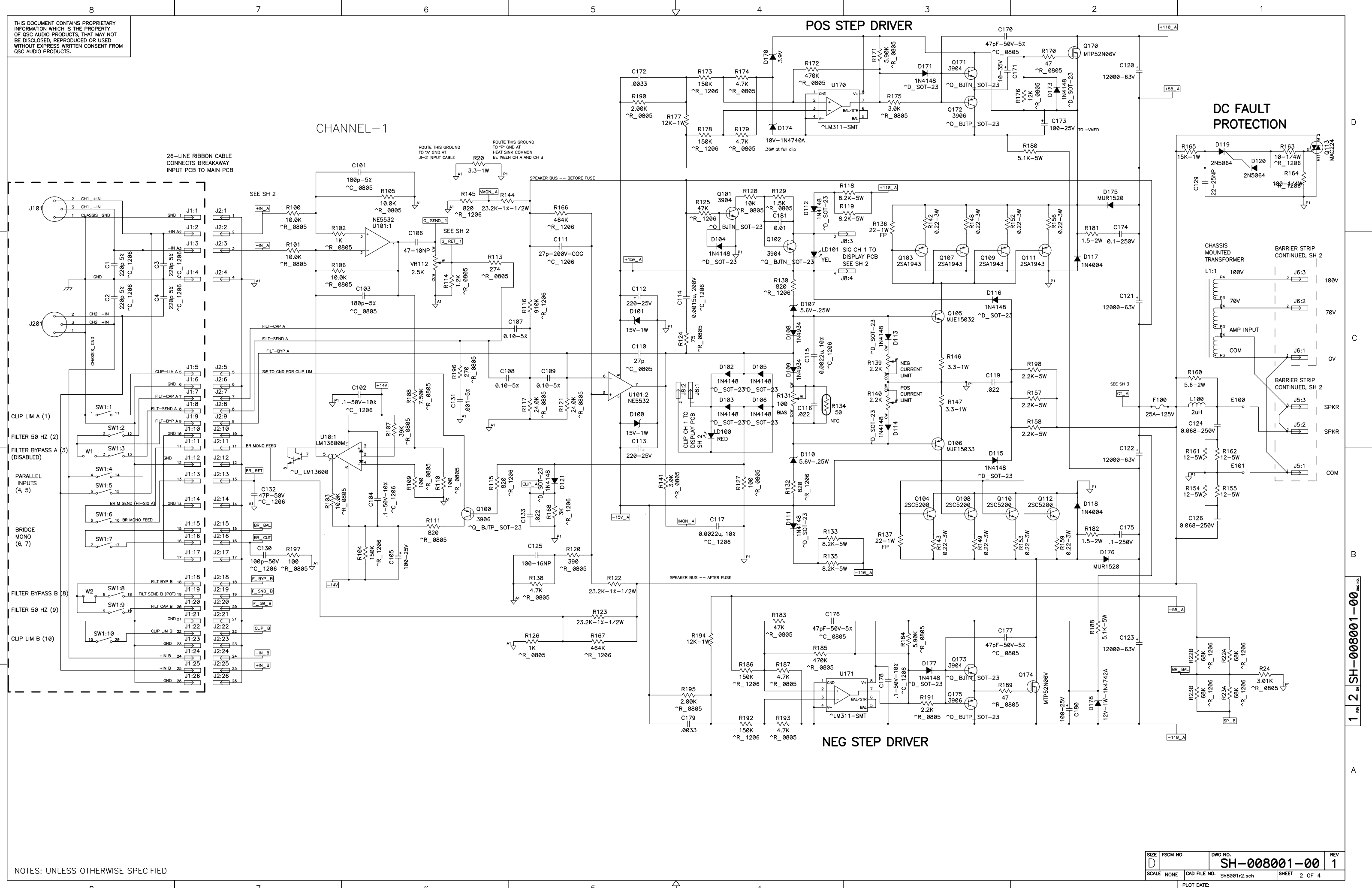

NOTES: UNLESS OTHERWISE SPECIFIED

SIZE	FSCM NO.	DWG NO.	REV
D		SH-008001-00	1
SCALE	CAD FILE NO.	SHEET 2 OF 4	
NONE	Sh8001r2.sch		

PLOT DATE: Mon Mar 19, 2001

1 of 2 SH-008001-00

THIS DOCUMENT CONTAINS PROPRIETARY INFORMATION WHICH IS THE PROPERTY OF QSC AUDIO PRODUCTS. THAT MAY NOT BE DISCLOSED, REPRODUCED OR USED WITHOUT EXPRESS WRITTEN CONSENT FROM QSC AUDIO PRODUCTS.

NOTE: THIS IS INTENDED TO CONNECT TO LOWER POS RAIL ON SAME SIDE AS DISPLAY LEADS

SERIES REGULATOR SUPPLIES APPROX 40MA TO HD-15 PORT

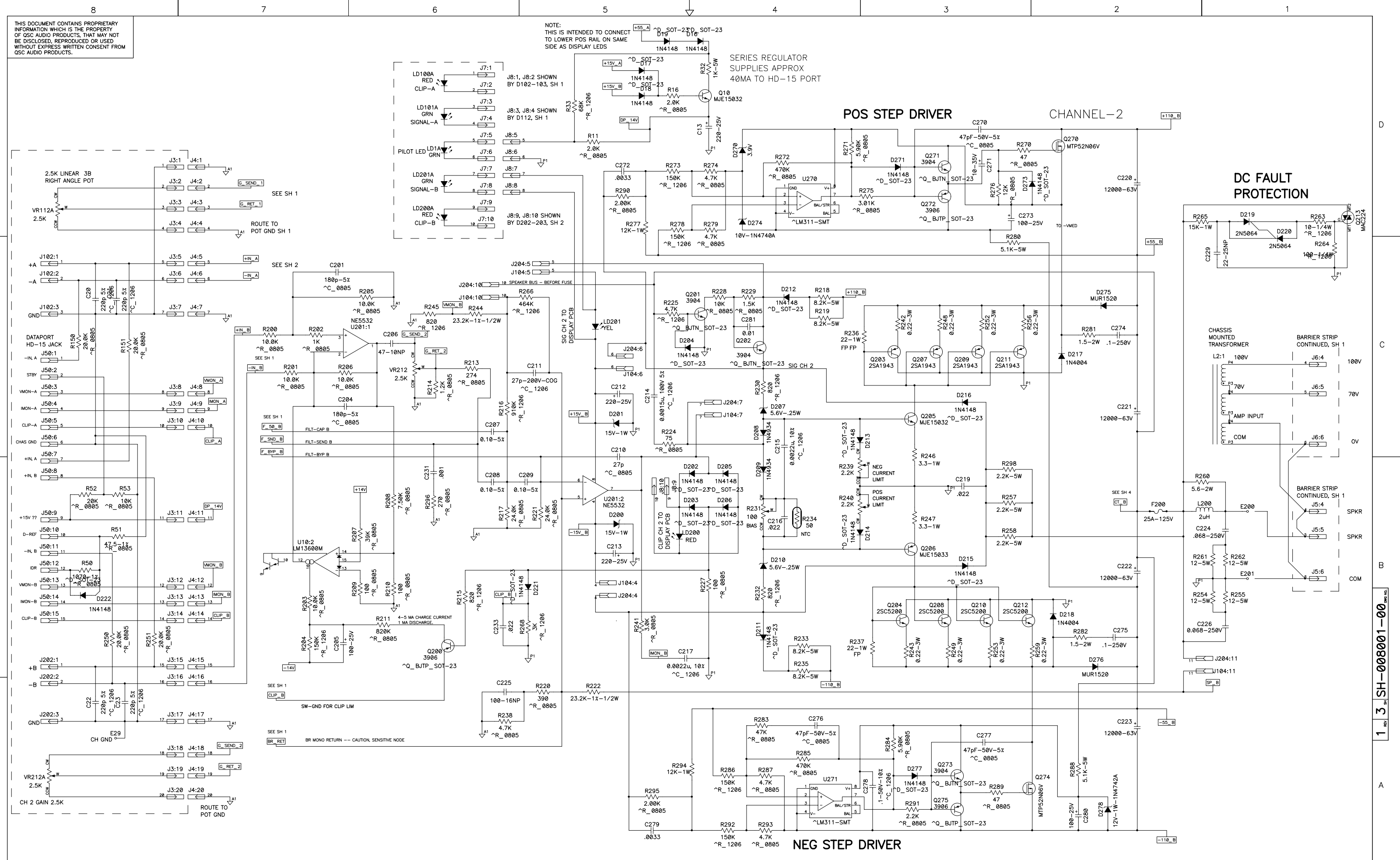

NOTES: UNLESS OTHERWISE SPECIFIED

SIZE	FSCM NO.	DWG NO.	REV
D		SH-008001-00	1
SCALE	CAD FILE NO.	SHEET	OF
NONE	Sh8001r2.sch	3	4

PLOT DATE: Mon Mar 19, 2001

1 3 SH-008001-00

THIS DOCUMENT CONTAINS PROPRIETARY INFORMATION WHICH IS THE PROPERTY OF QSC AUDIO PRODUCTS, THAT MAY NOT BE DISCLOSED, REPRODUCED OR USED WITHOUT EXPRESS WRITTEN CONSENT FROM QSC AUDIO PRODUCTS.

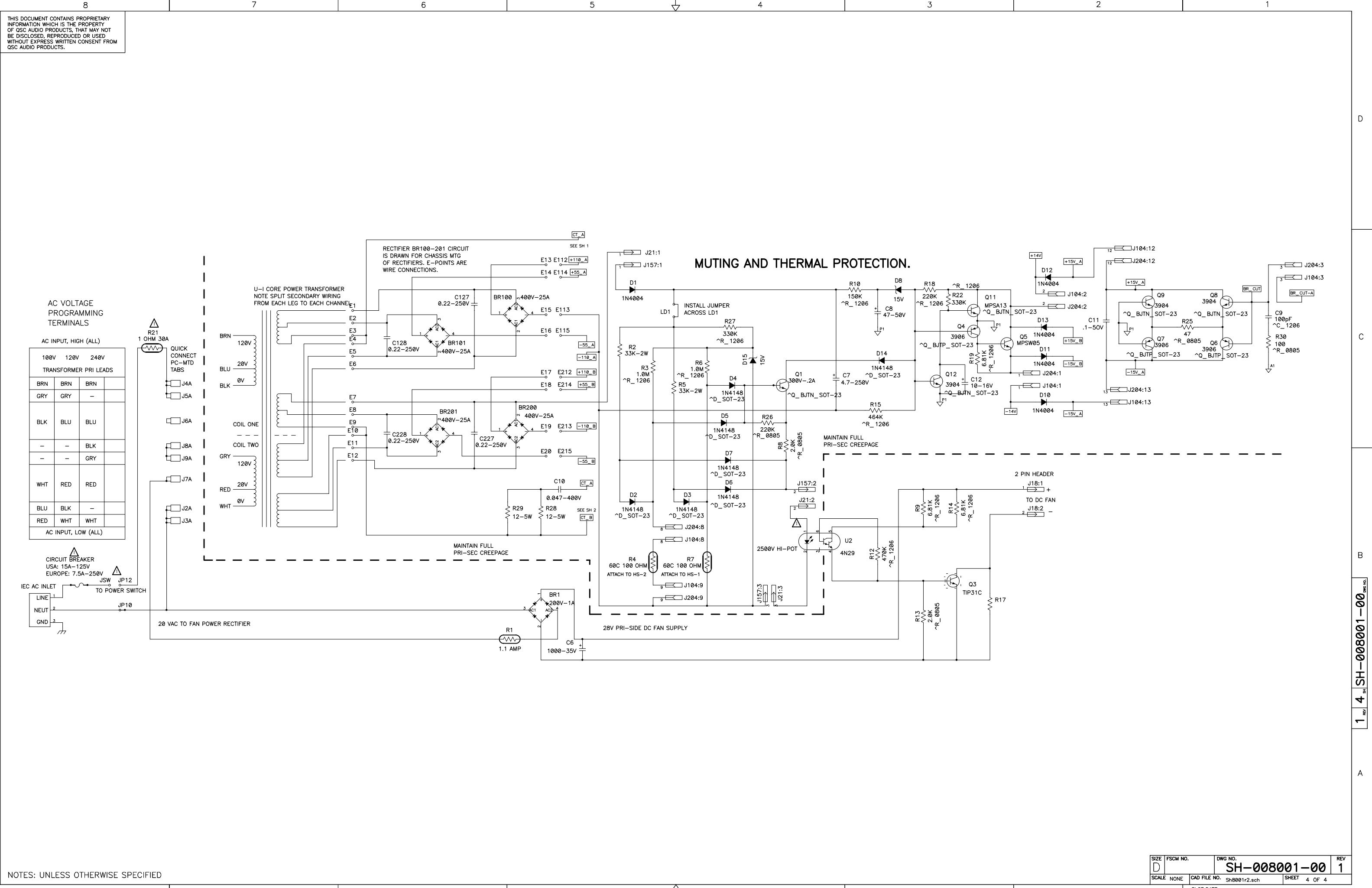

NOTES: UNLESS OTHERWISE SPECIFIED

SIZE D	FSCM NO.	DWG NO. SH-008001-00	REV 1
SCALE NONE	CAD FILE NO. Sh8001r2.sch	SHEET 4 OF 4	
PLOT DATE: Mon Mar 19, 2001			

1 REV 4 SH-008001-00