

This document and the data disclosed herein or herewith is not to be reproduced, used, or disclosed in whole or in part to anyone without the written permission of THAT Corporation.

| Rev | Description | Date | Approved |
|-----|--------------|---------|----------|
| 00 | Released | 7/7/99 | |
| 01 | Per ECO #197 | 8/30/99 | |

Dataports A,B,C,D
313-0201.SCH



VMON & IMON Input Select 2 of 2
313-0801.SCH



Dataports E,F,G,H
313-0301.SCH



VMON & IMON RMS Detectors
313-0901.SCH



Dataports I,J,K,L
313-0401.SCH



Amp Monitor Mix 1 of 2
313-1001.SCH



Dataports M,N,O
313-0501.SCH



Amp Monitor Mix 2 of 2
313-1101.SCH



Standby & Bypass Relays and Power Input
313-0601.SCH



Center Channel Bypass
313-1201.SCH



VMON & IMON Input Select 1 of 2
313-0701.SCH



Analog Switch & Digital Pot Control
313-1301.SCH



UNLESS OTHERWISE NOTED:

- 1.0 All resistor values are expressed in Ohms.
- 1.1 All resistors are 1/4 Watt types with their tolerance and material coded into their value.

| VALUE | 1%, Metal Film | 5%, Carbon Film |
|------------------------|----------------|-----------------|
| 0 Ohm to 0.99 Ohms | 0R to 0R976 | 0R to 0R91 |
| 1 Ohm to 99 Ohms | 1R00 to 97R6 | 1R0 to 91R |
| 100 Ohms to 999 Ohms | 100R0 to 976R0 | 100R to 910R |
| 1k Ohm to 9k9 Ohms | 1k00 to 9k76 | 1k0 to 9k1 |
| 10k Ohms to 99k Ohms | 10k0 to 97k6 | 10k to 91k |
| 100k Ohms to 999k Ohms | 100k0 to 976k0 | 100k to 910k |
| 1M Ohm to 99M Ohms | 1M00 to 97M6 | 1M0 to 91M |

- 2. All resistor networks are 2%, 1/8 Watt types with their values expressed in Ohms.
- 3.0 All capacitor values are expressed in Farads
- 3.1 All 100n bypass capacitors are 20%, 50 Volt, Z5U, Ceramic Monolythic types.
Their Reference Designators are coded as CVXXX where XXX is the associated IC number and V is the associated power supply voltage.
Values for V are; 9 = +5, 8 = -5, 7 = +15, 6 = -15, 5 = +12, 4 = -12.
- 3.2 All non-electrolytic capacitors are 10%, 50 Volt, X7R, Ceramic Monolythic types.
- 3.3 All NPO capacitors are 5%, 50 Volt, Ceramic Monolythic types.
- 3.4 All MY capacitors are 5%, 50 Volt, Metalized Polyester types.
- 3.5 All PP capacitors are 5%, 50 Volt, Metalized Polypropylene types.
- 3.6 All PC capacitors are 5%, 50 Volt, Metalized Polycarbonate types.
- 3.7 All electrolytic capacitors are 20%, 16 Volt (or higher), Aluminum Electrolyte types.
- 3.8 All TA capacitors are 20%, 16 Volt (or higher), Tantalum Electrolyte types.
- 4. For complete information on any component please see the associated bill of materials.
- 5. All net names preceded by a / are active low signals.
- 6. IC power supply connections are called out in a table at the bottom of the page(s) the IC appears on.
Only non-standard or unique power supply connections will be shown on the schematic sheet.
- 7. V+ = +12, V- = -12, VCC = +5, VEE = -5

THAT Corporation 45 Sumner Street
Milford, MA
508-478-9200

| | | |
|-------------|-------|--|
| Checked: | Date: | Title: QSC Digital Cinema Monitor DCM-2/DCM-3 Monitor Board |
| Proj. Eng.: | Date: | |
| Chf. Eng.: | Date: | Size: B Drawing Number: 330313 Revision: 01 |
| Production: | Date: | Date: 19-Sep-2002 Drawn by: CMH Sheet 1 of 13 File: F:\DM\SH\SH004051gp\CUR China REV\313-01011.DDB - Documents\313-0 |

This document and the data disclosed herein or herewith is not to be reproduced, used, or disclosed in whole or in part to anyone without the written permission of THAT Corporation.

| Rev | Description | Date | Approved |
|-----|-------------|------|----------|
| | | | |

DATAPORT A

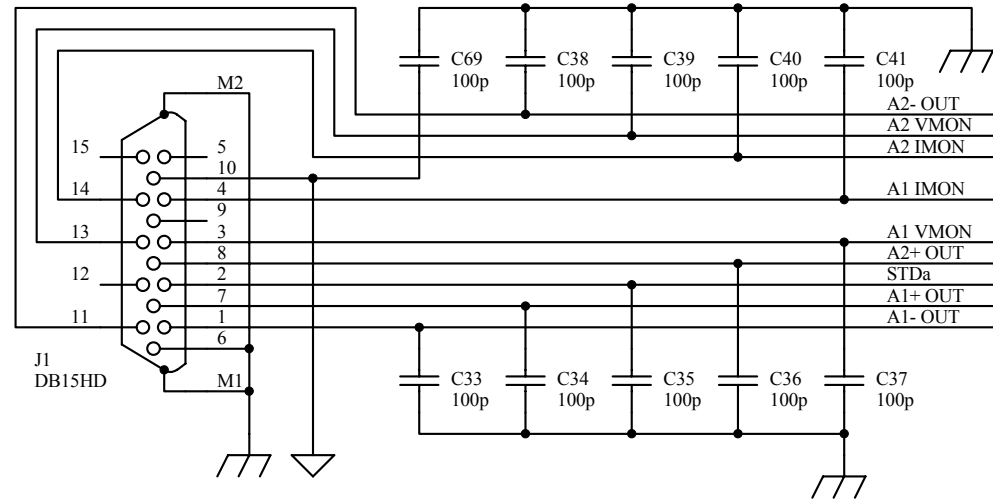

DATAPORT C

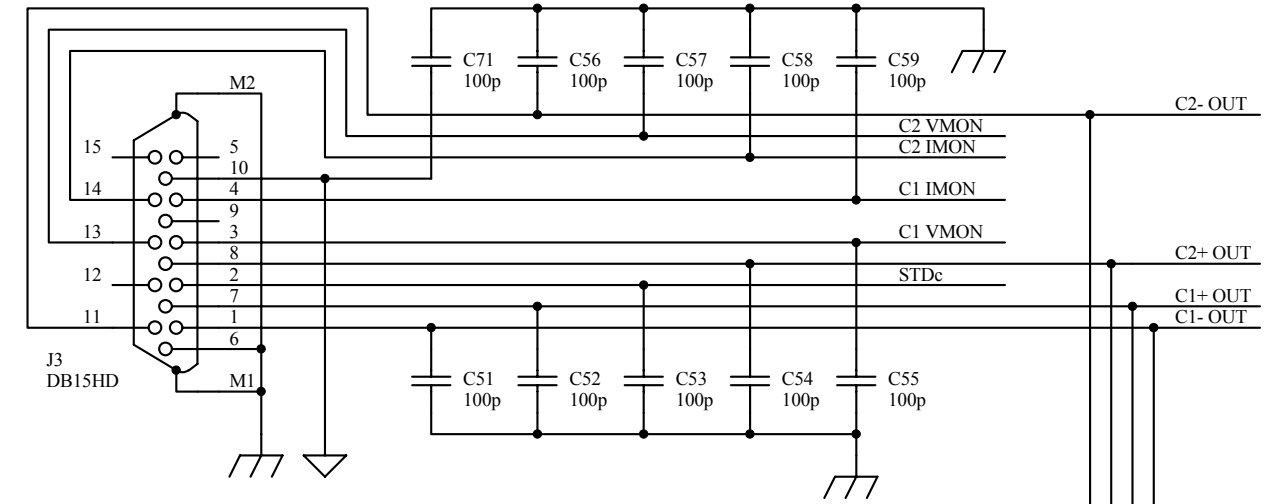

DATAPORT B

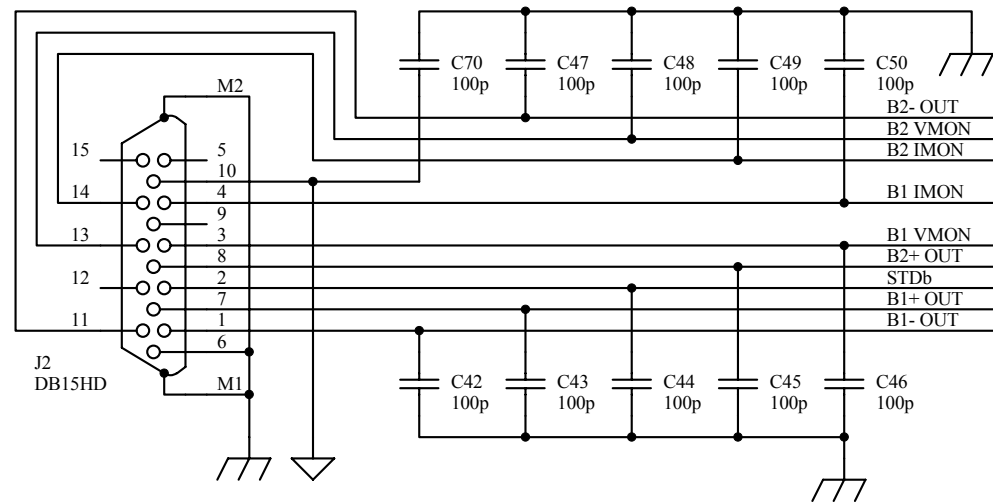

DATAPORT D

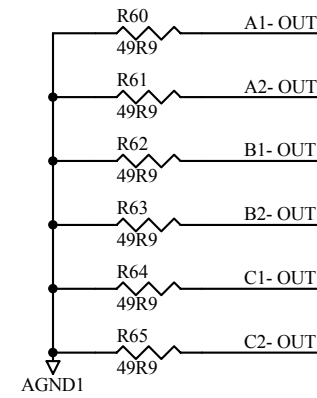
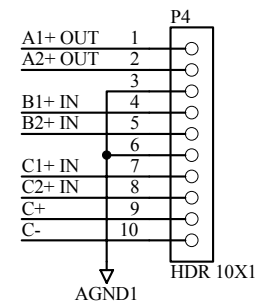
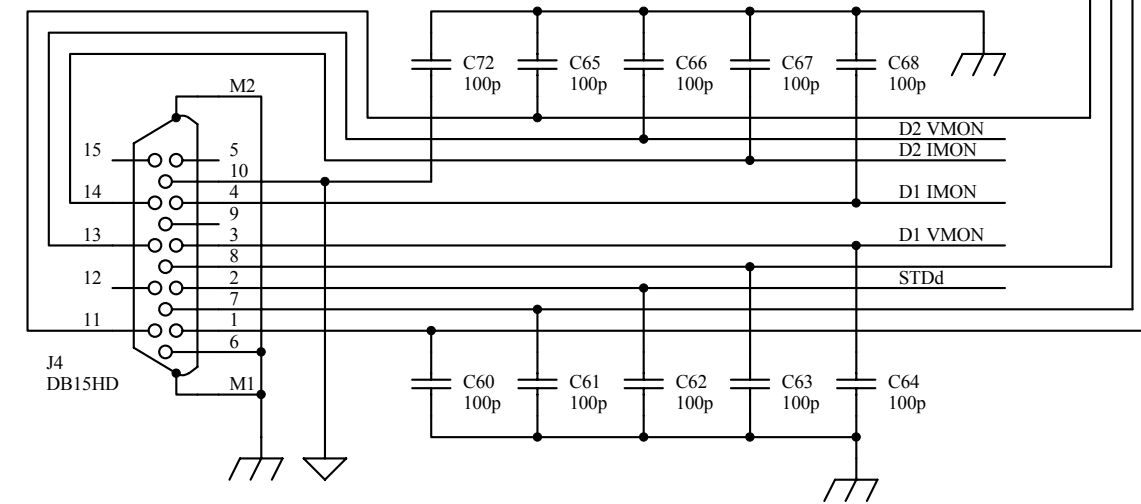

THAT Corporation 45 Sumner Street
 Milford, MA
 508-478-9200

Title: **DCM-2/DCM-3 Rear Monitor**
 Dataports A,B,C,D

| | |
|-------------|-------|
| Checked: | Date: |
| Proj. Eng.: | Date: |
| Chf. Eng.: | Date: |
| Production: | Date: |

| | | |
|---|-------------------------------|---------------------|
| Size: B | Drawing Number: 330313 | Revision: 01 |
| Date: 19-Sep-2002 | Drawn by: CMH | Sheet 2 of 13 |
| File: F:\DM\SH\SH004051gp\CUR China REV\313-01011.DDB - Documents\313-0 | | |

This document and the data disclosed herein or herewith is not to be reproduced, used, or disclosed in whole or in part to anyone without the written permission of THAT Corporation.

| Rev | Description | Date | Approved |
|-----|-------------|------|----------|
| | | | |

DATAPOINT E

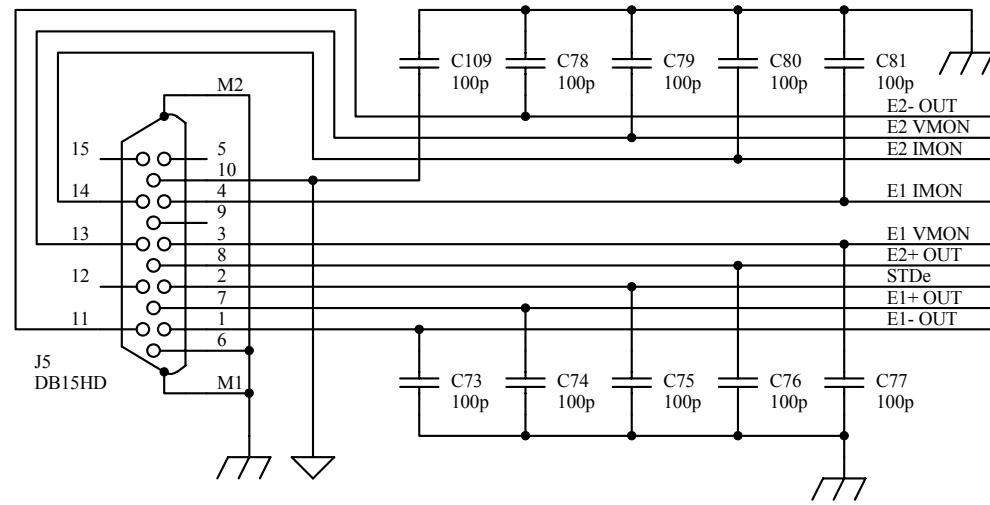

DATAPOINT G
(SUBS 1 & 2)

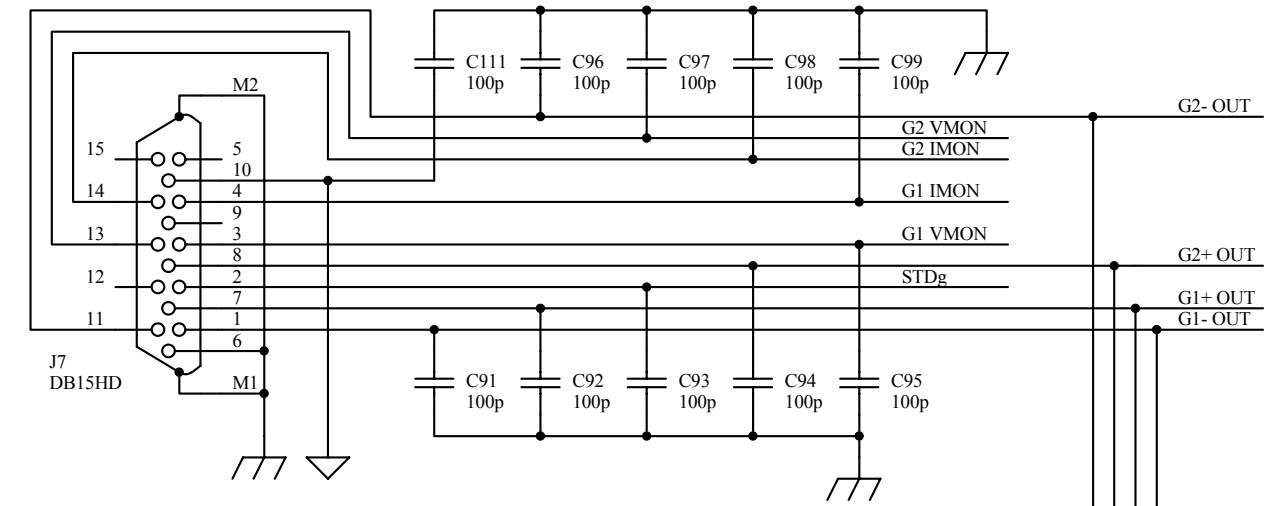

DATAPOINT F

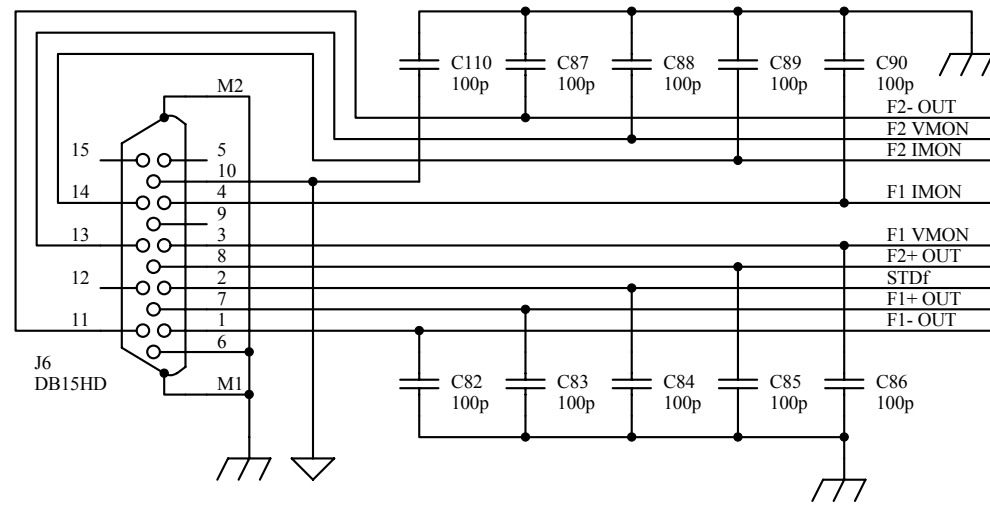

DATAPOINT H
(SUBS 3 & 4)

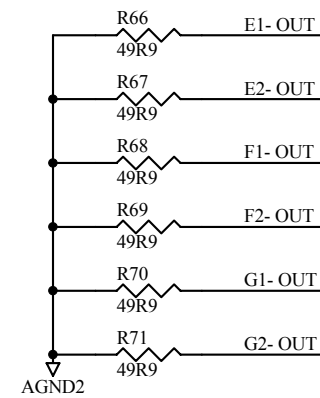
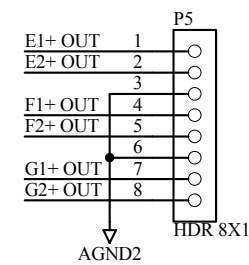
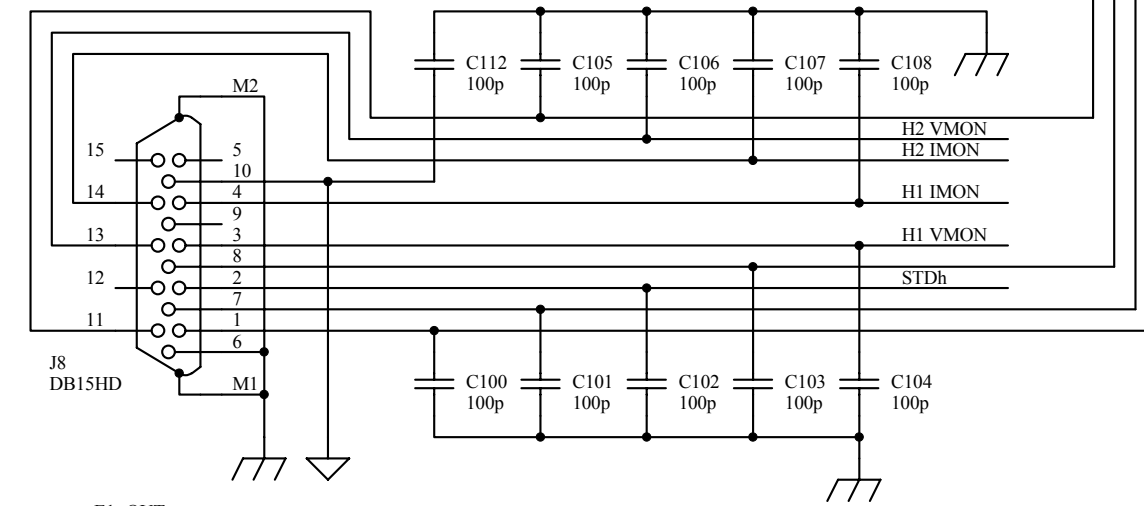

THAT Corporation 45 Sumner Street
Milford, MA 508-478-9200

Title: **DCM-2/DCM-3 Monitor Board**
Dataports E,F,G,H

| | |
|-------------|-------|
| Checked: | Date: |
| Proj. Eng.: | Date: |
| Chf. Eng.: | Date: |
| Production: | Date: |

| | | |
|---|-------------------------------|---------------------|
| Size: B | Drawing Number: 330313 | Revision: 01 |
| Date: 19-Sep-2002 | Drawn by: CMH | Sheet 3 of 13 |
| File: F:\DM\SH\SH004051gp\CUR China REV\313-01011.DDB - Documents\313-0 | | |

This document and the data disclosed herein or herewith is not to be reproduced, used, or disclosed in whole or in part to anyone without the written permission of THAT Corporation.

| Rev | Description | Date | Approved |
|-----|-------------|------|----------|
| | | | |

DATAPOINT I

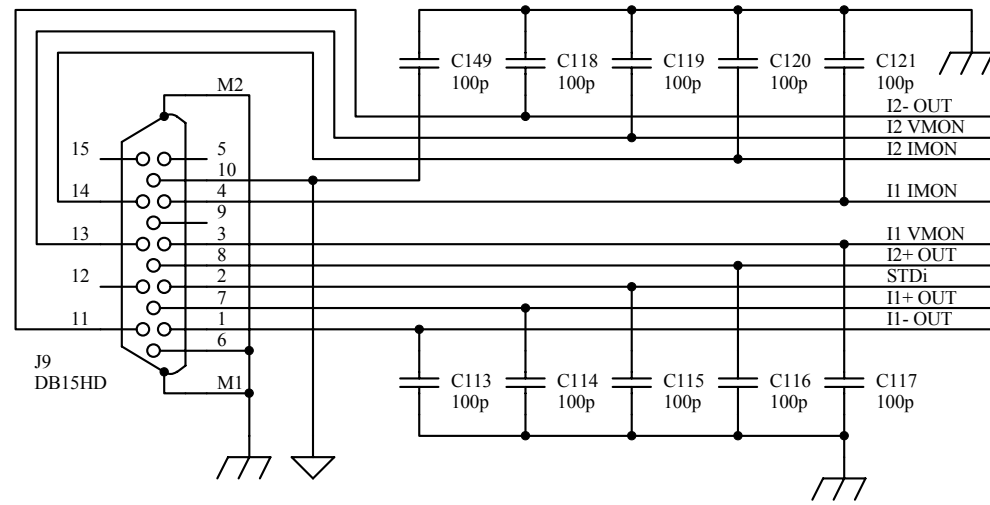

DATAPOINT K

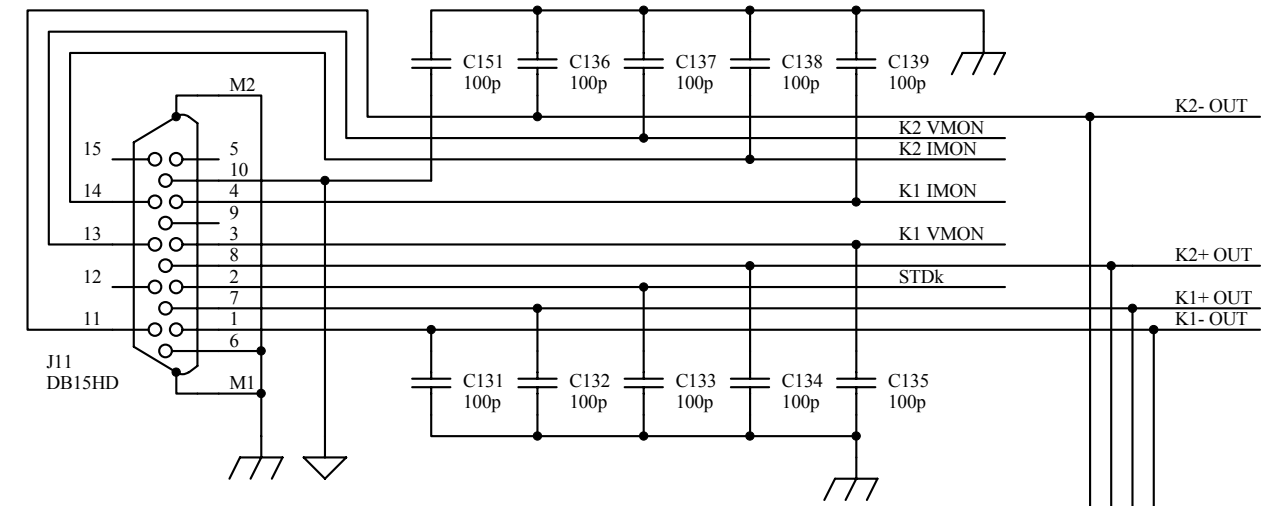

DATAPOINT J

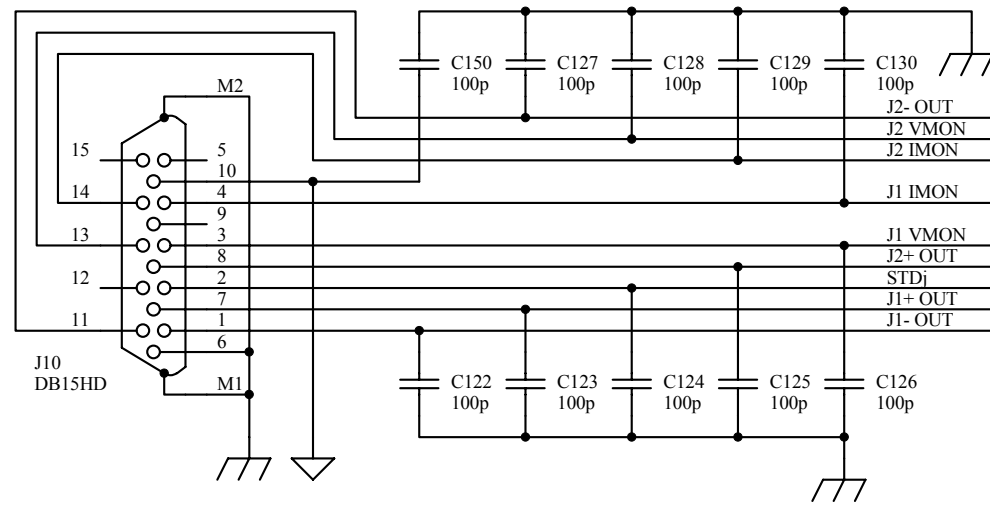

DATAPOINT L

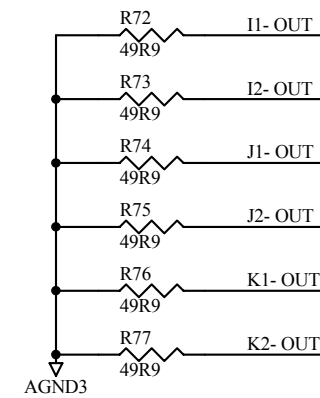
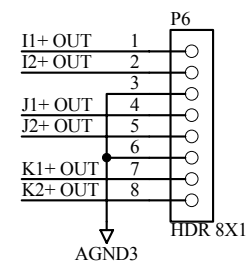
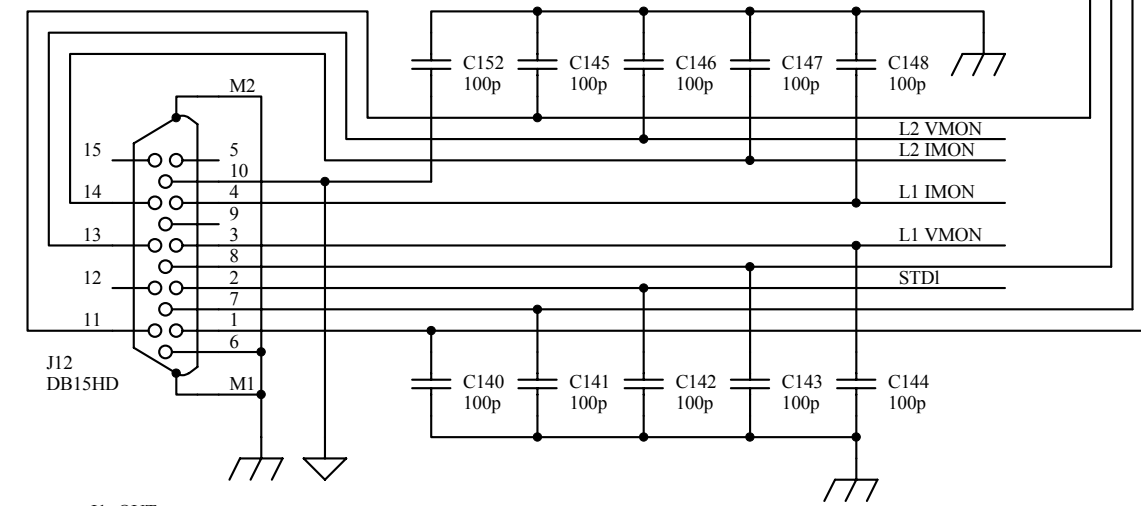

DCM-3 only

THAT Corporation 45 Sumner Street
Milford, MA
508-478-9200

Title: **DCM-2/DCM-3 Monitor Board**
Dataports I,J,K,L

| | |
|-------------|-------|
| Checked: | Date: |
| Proj. Eng.: | Date: |
| Chf. Eng.: | Date: |
| Production: | Date: |

| | | |
|---|-------------------------------|---------------------|
| Size: B | Drawing Number: 330313 | Revision: 01 |
| Date: 19-Sep-2002 | Drawn by: CMH | Sheet 4 of 13 |
| File: F:\DM\SH\SH004051gp\CUR China REV\313-01011.DDB - Documents\313-0 | | |

This document and the data disclosed herein or herewith is not to be reproduced, used, or disclosed in whole or in part to anyone without the written permission of THAT Corporation.

| Rev | Description | Date | Approved |
|-----|-------------|------|----------|
| | | | |

DATAPORT M
(Surround 1)

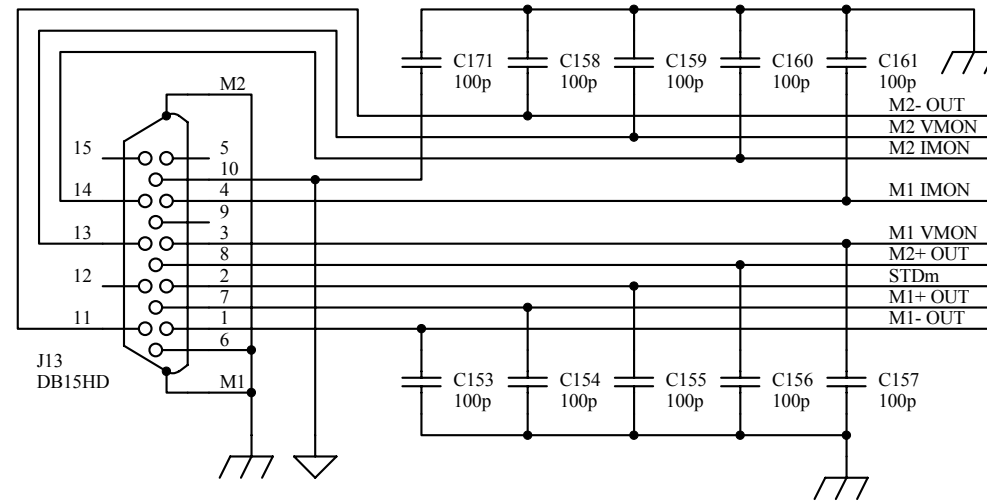

DATAPORT N
(Surround 2)

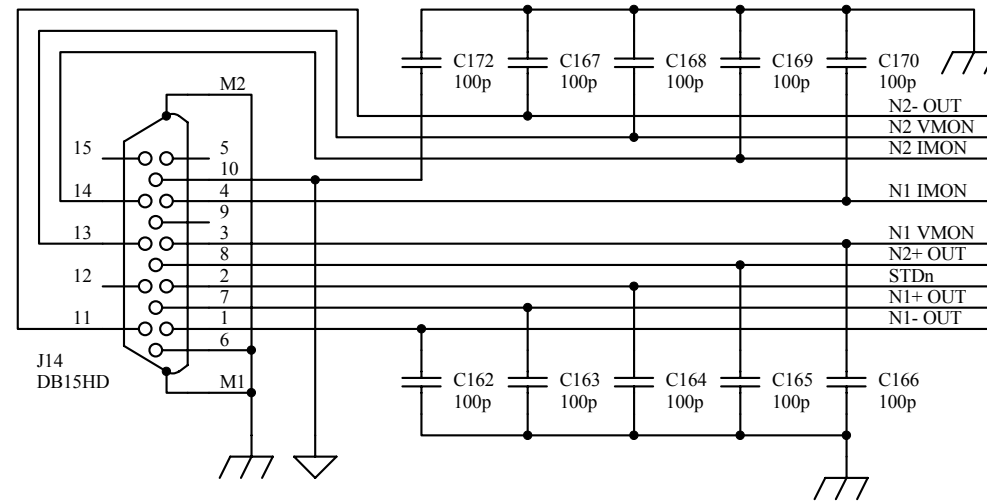

DATAPORT O
(Surround 3)

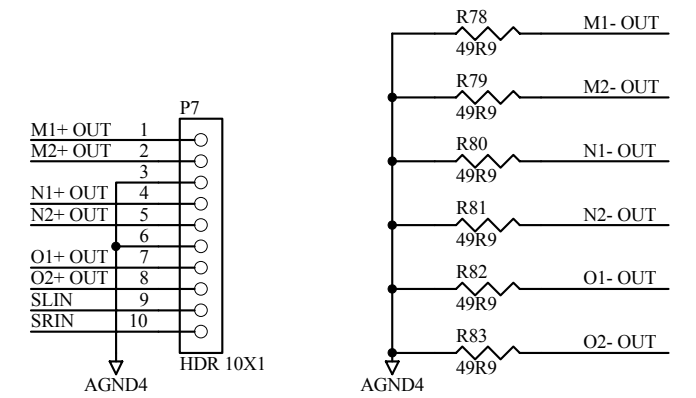
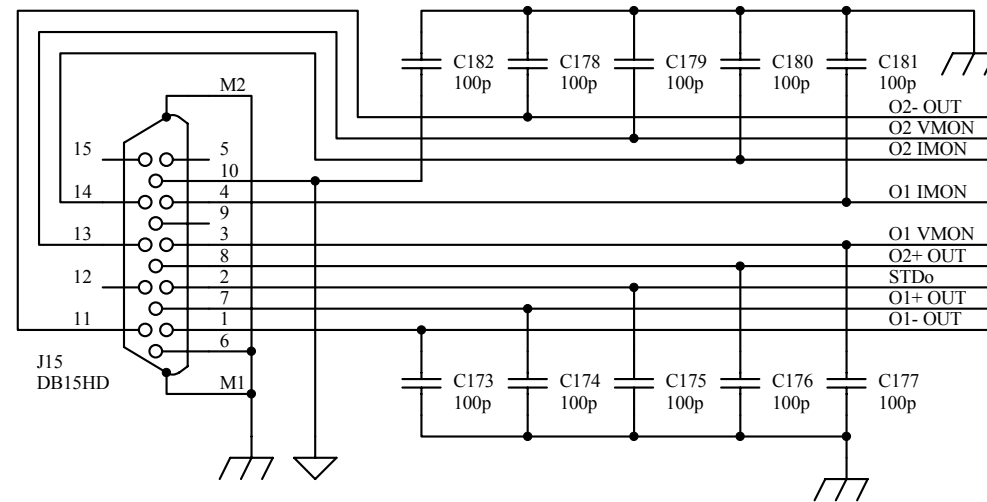

THAT Corporation 45 Sumner Street
Milford, MA
508-478-9200

Title: **DCM-2/DCM-3 Monitor Board**
Dataports M,N,O (Surrounds)

| | |
|-------------|-------|
| Checked: | Date: |
| Proj. Eng.: | Date: |
| Chf. Eng.: | Date: |
| Production: | Date: |

| | | |
|---|-------------------------------|---------------------|
| Size: B | Drawing Number: 330313 | Revision: 01 |
| Date: 19-Sep-2002 | Drawn by: CMH | Sheet 5 of 13 |
| File: F:\DM\SH\SH004051gp\CUR China REV\313-01011.DDB - Documents\313-0 | | |

This document and the data disclosed herein or herewith is not to be reproduced, used, or disclosed in whole or in part to anyone without the written permission of THAT Corporation.

| Rev | Description | Date | Approved |
|-----|-------------|------|----------|
| | | | |

D

C

B

A

D

C

B

A

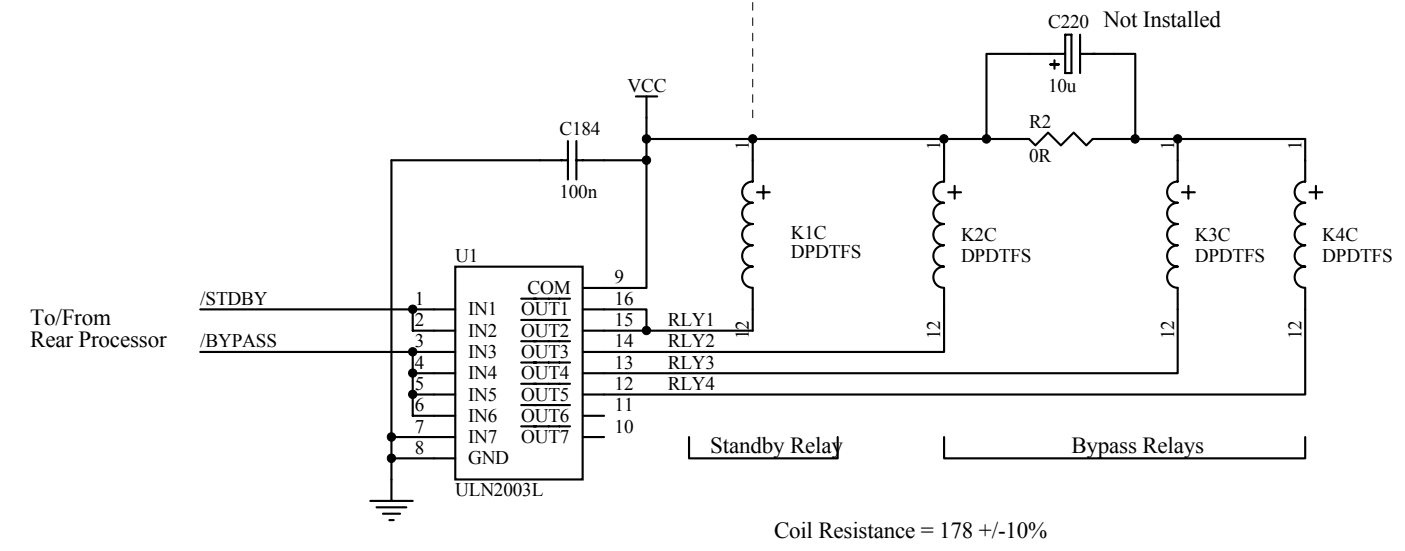
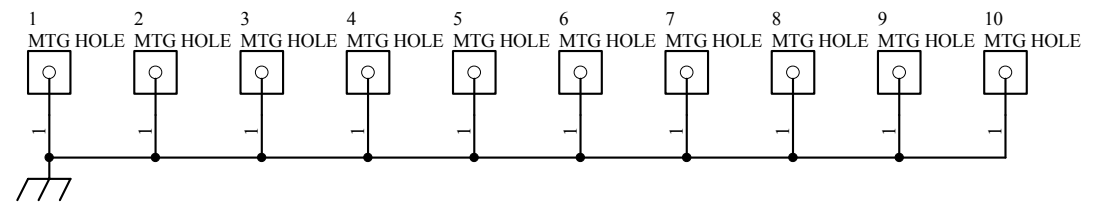
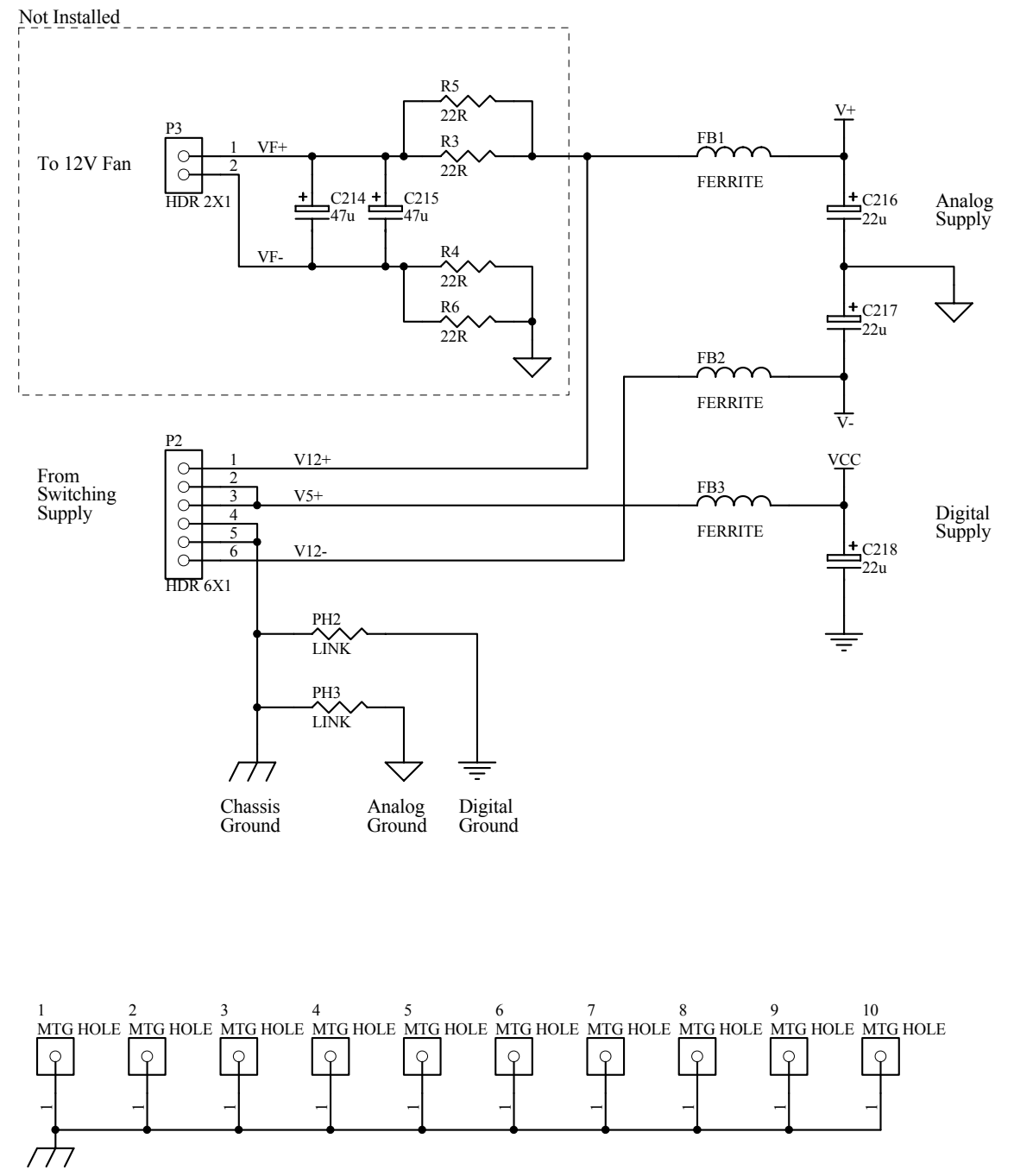
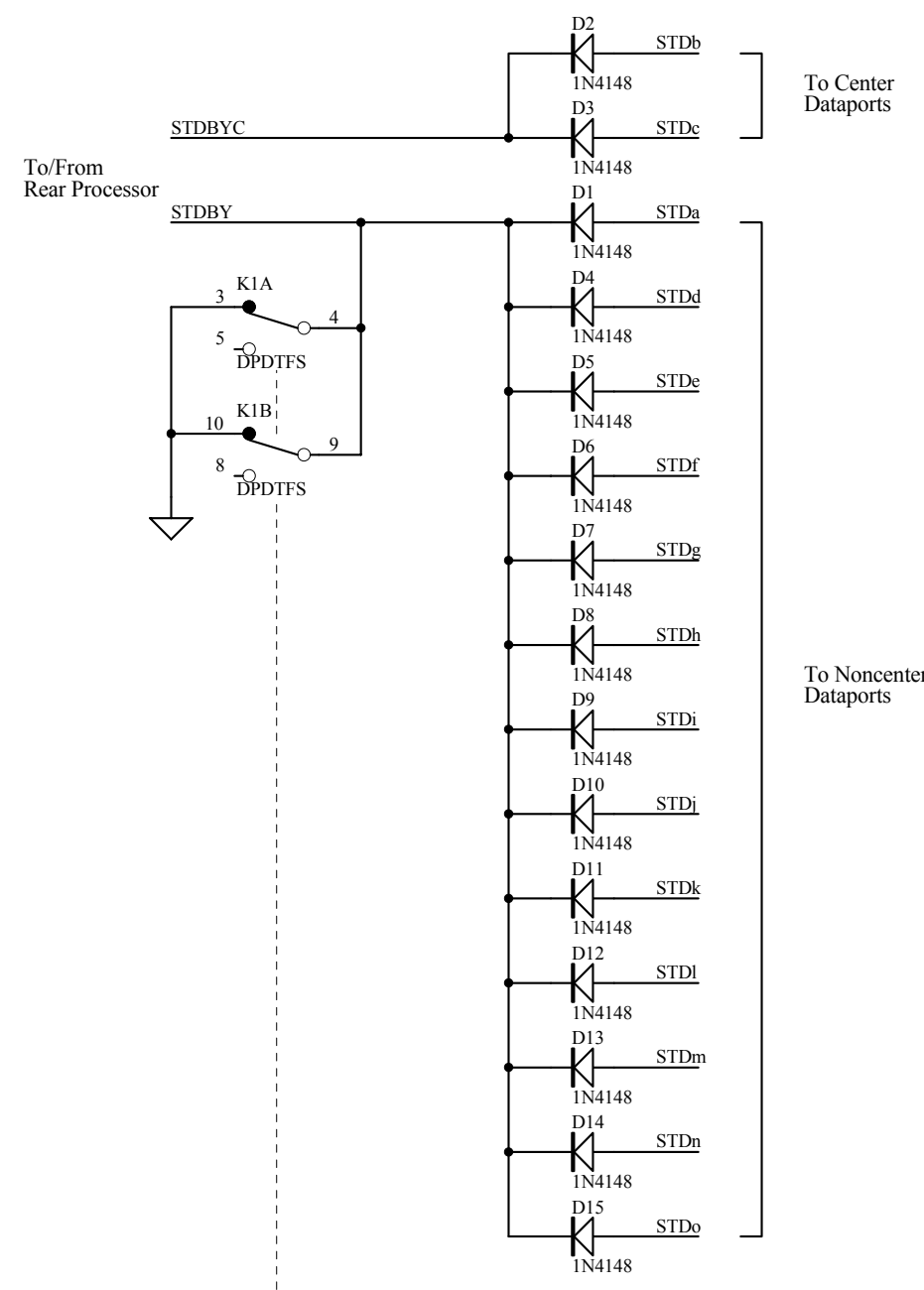

THAT Corporation 45 Sumner Street
Milford, MA 01854
508-478-9200

Title: **DCM-2/DCM-3 Monitor Board**
Standby & Bypass Relays and Power Input

| | |
|-------------|-------|
| Checked: | Date: |
| Proj. Eng.: | Date: |
| Chf. Eng.: | Date: |
| Production: | Date: |

| | | |
|---|-------------------------------|---------------------|
| Size: B | Drawing Number: 330313 | Revision: 01 |
| Date: 19-Sep-2002 | Drawn by: CMH | Sheet 6 of 13 |
| File: F:\DM\SH\SH004051gp\CUR China REV\313-01011.DDB - Documents\313-0 | | |

This document and the data disclosed herein or herewith is not to be reproduced, used, or disclosed in whole or in part to anyone without the written permission of THAT Corporation.

| Rev | Description | Date | Approved |
|-----|-------------|------|----------|
| | | | |

D

C

B

A

D

C

B

A

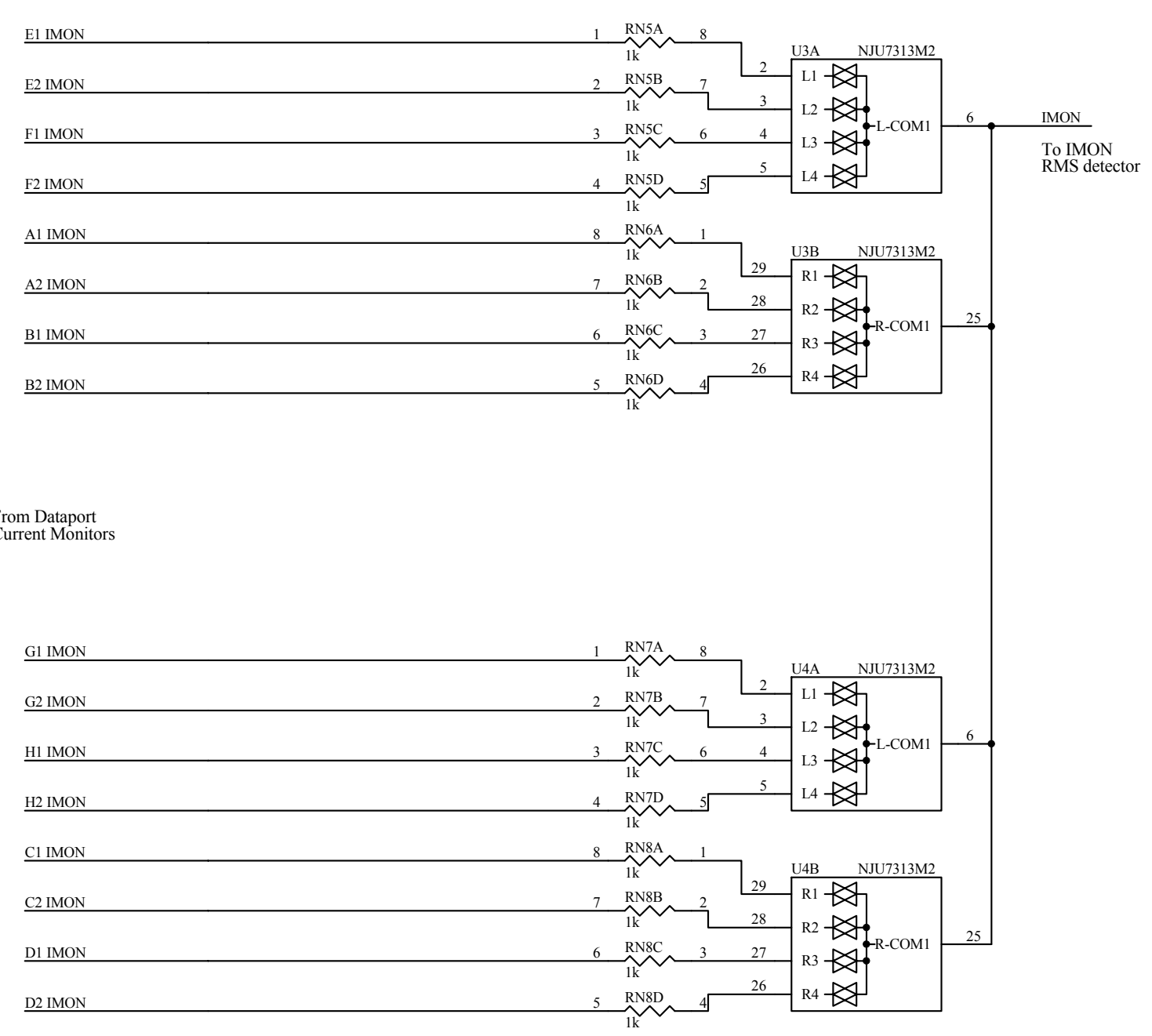
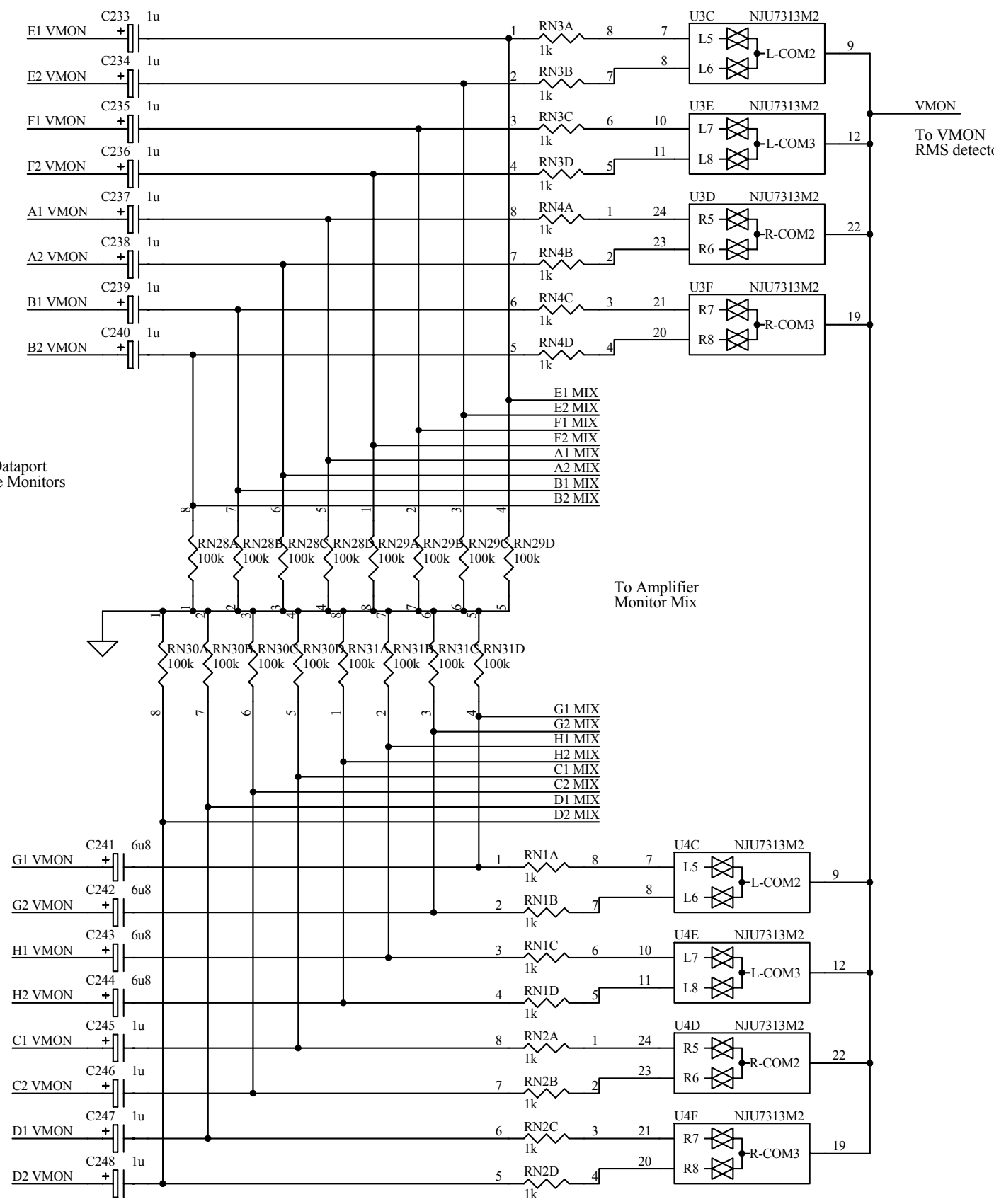

THAT Corporation 45 Sumner Street
Milford, MA 01854
508-478-9200

Title: **DCM-2/DCM-3 Monitor Board**
VMON & IMON Input Select

| | |
|-------------|-------|
| Checked: | Date: |
| Proj. Eng.: | Date: |
| Chf. Eng.: | Date: |
| Production: | Date: |

| | | |
|---|-------------------------------|---------------------|
| Size: B | Drawing Number: 330313 | Revision: 01 |
| Date: 19-Sep-2002 | Drawn by: CMH | Sheet 7 of 13 |
| File: F:\DM\SH\SH004051gp\CUR_China_REV\313-01011.DDB - Documents\313-0 | | |

This document and the data disclosed herein or herewith is not to be reproduced, used, or disclosed in whole or in part to anyone without the written permission of THAT Corporation.

| Rev | Description | Date | Approved |
|-----|-------------|------|----------|
| | | | |

D

C

B

A

D

C

B

A

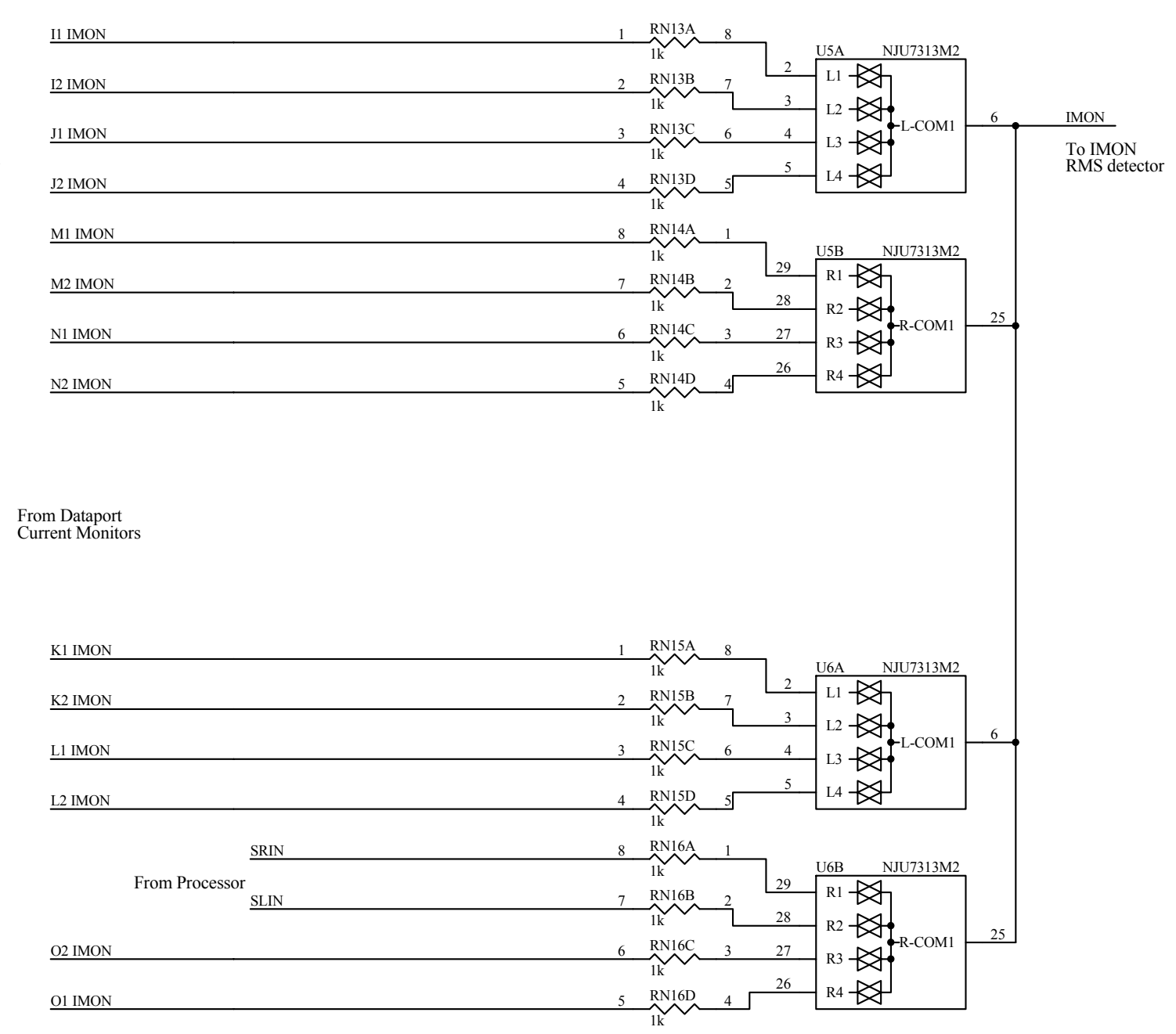
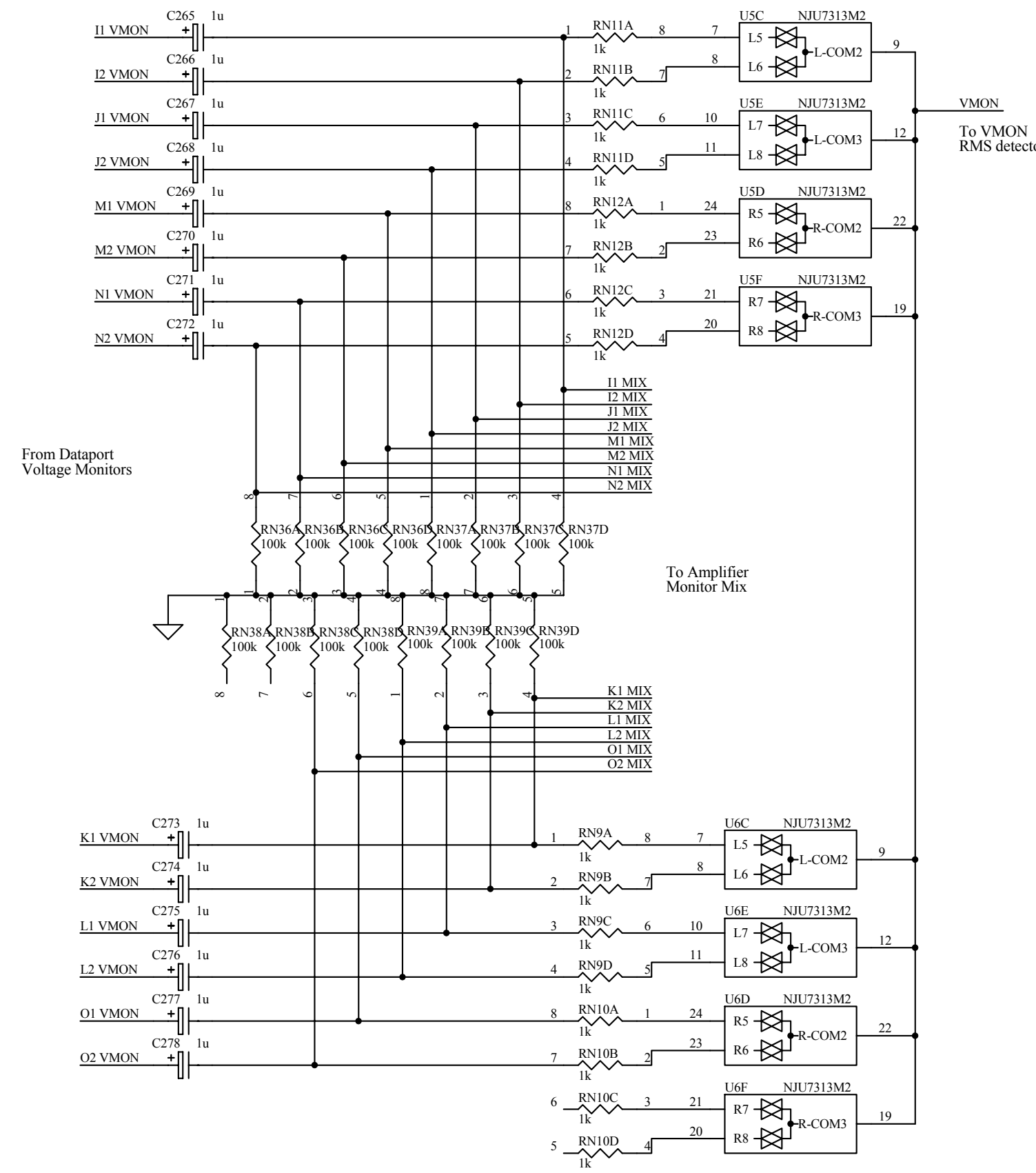

THAT Corporation 45 Sumner Street
Milford, MA 01854
508-478-9200

Title: **DCM-2/DCM-3 Monitor Board**
VMON & IMON Input Select

| | |
|-------------|-------|
| Checked: | Date: |
| Proj. Eng.: | Date: |
| Chf. Eng.: | Date: |
| Production: | Date: |

| | | |
|---|-------------------------------|---------------------|
| Size: B | Drawing Number: 330313 | Revision: 01 |
| Date: 19-Sep-2002 | Drawn by: CMH | Sheet 8 of 13 |
| File: F:\DM\SH\SH004051gp\CUR_China_REV\313-01011.DDB - Documents\313-0 | | |

This document and the data disclosed herein or herewith is not to be reproduced, used, or disclosed in whole or in part to anyone without the written permission of THAT Corporation.

| Rev | Description | Date | Approved |
|-----|-------------|------|----------|
| | | | |

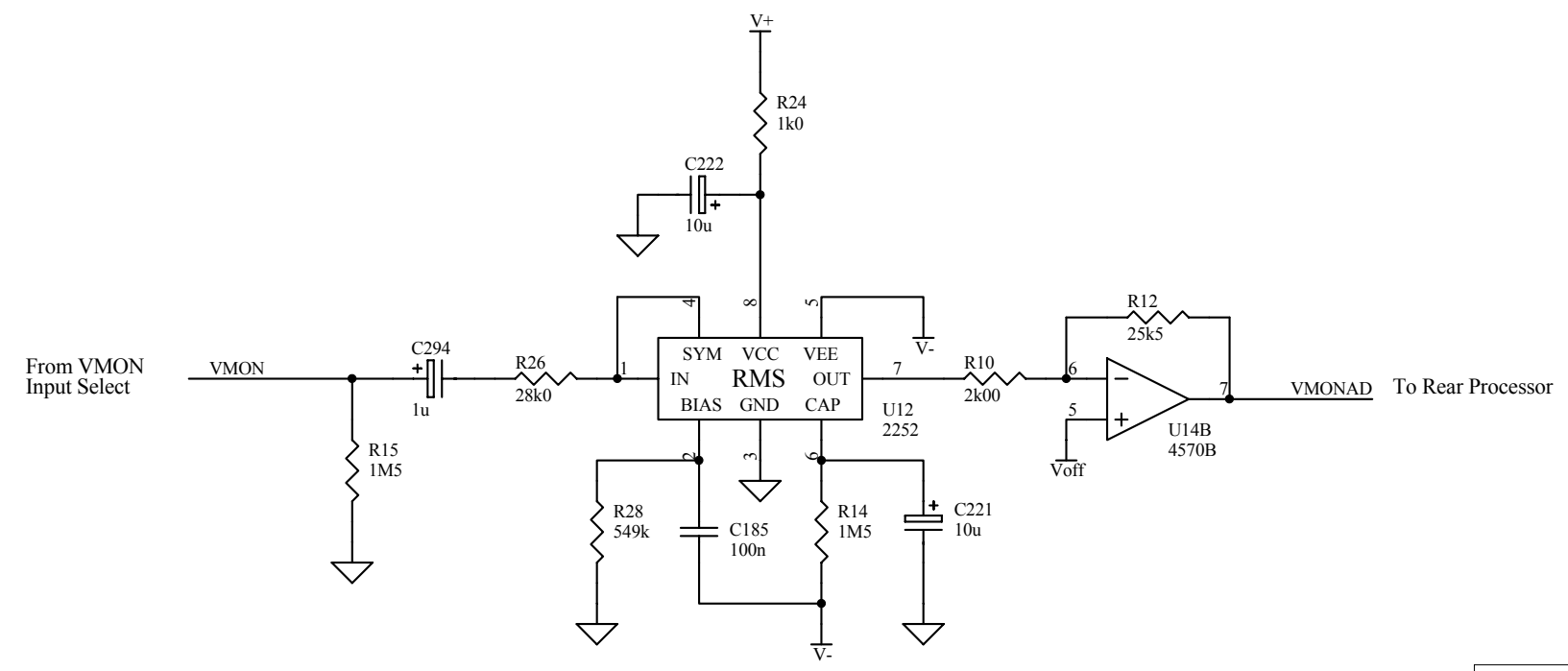

| Input (dBV) | Output (V) |
|---------------|-------------|
| +10.75 | 0.02 |
| ⋮ | ⋮ |
| 0.25 dB steps | 20 mV steps |
| -53.0 | 5.0 |

time constant = 35mS

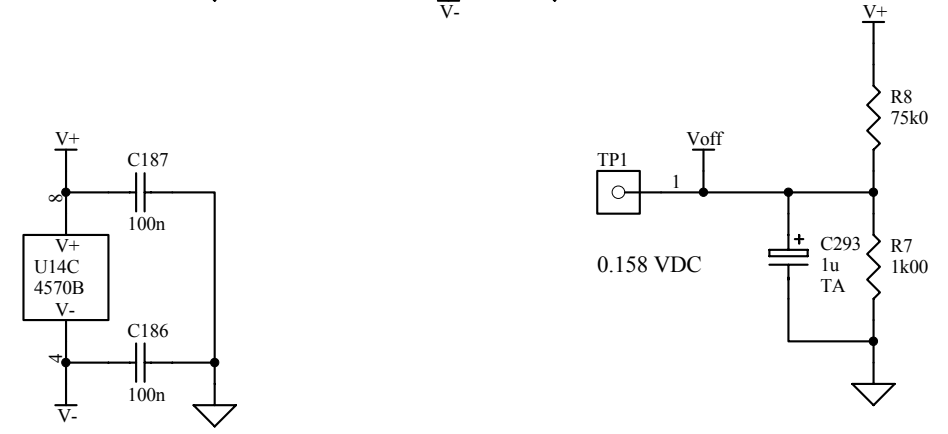
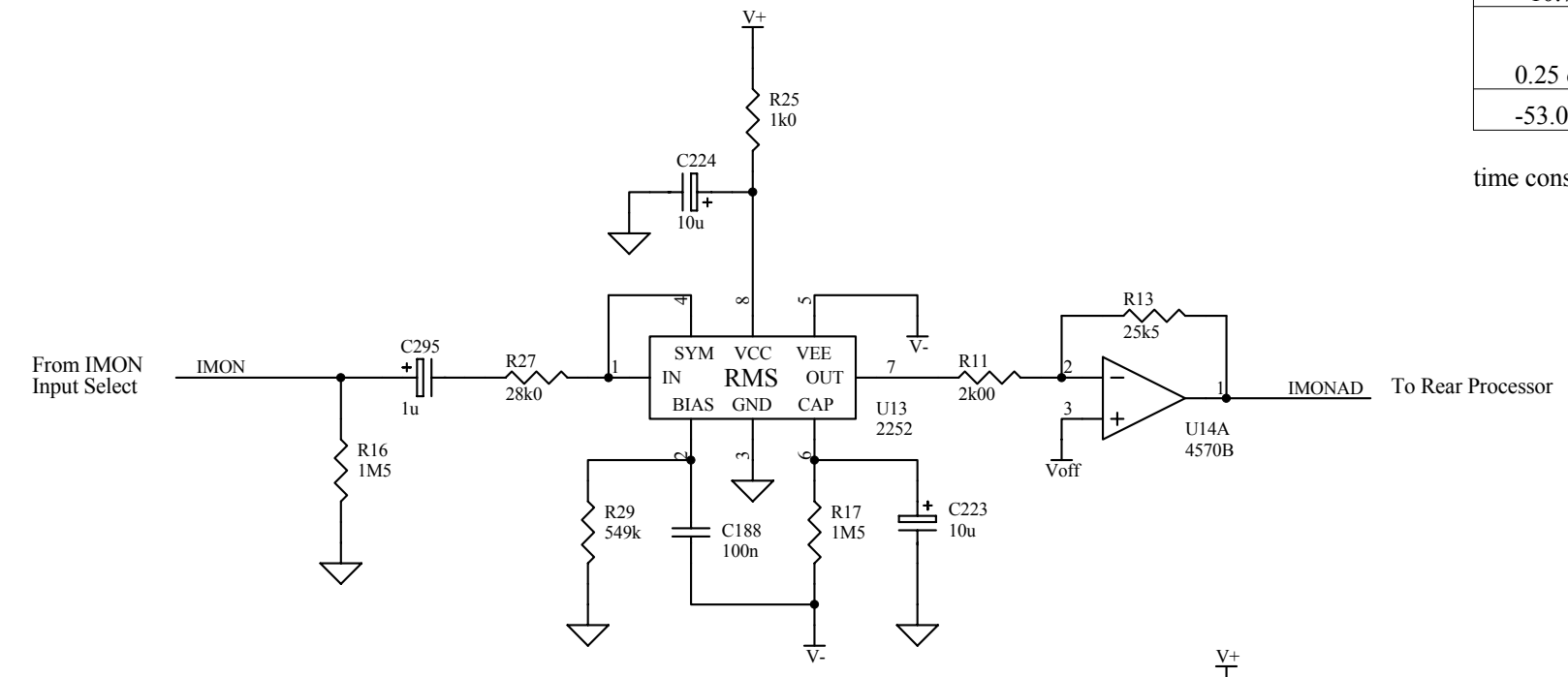

THAT Corporation 45 Sumner Street
Milford, MA 508-478-9200

Title: **DCM-2/DCM-3 Monitor Board**
Amp Voltage Monitor

| | | | | |
|-------------|-------|---|-------------------------------|---------------------|
| Checked: | Date: | Size: B | Drawing Number: 330313 | Revision: 01 |
| Proj. Eng.: | Date: | Date: 19-Sep-2002 | Drawn by: CMH | Sheet 9 of 13 |
| Chf. Eng.: | Date: | File: F:\DM\SH\SH004051gp\CUR China REV\313-01011.DDB - Documents\313-0 | | |
| Production: | Date: | | | |

This document and the data disclosed herein or herewith is not to be reproduced, used, or disclosed in whole or in part to anyone without the written permission of THAT Corporation.

| Rev | Description | Date | Approved |
|-----|-------------|------|----------|
| | | | |

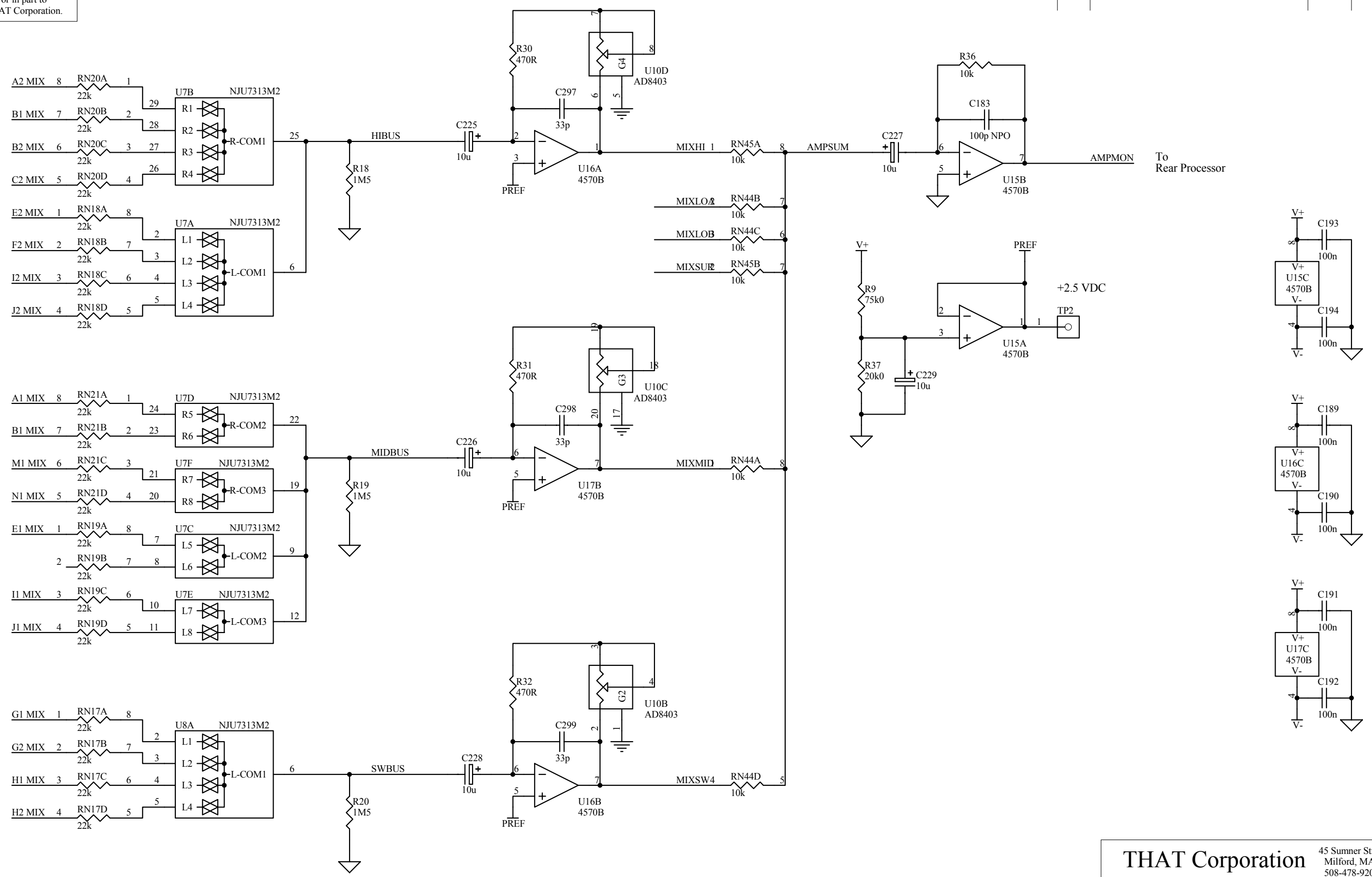

From Dataport VMON Inputs

To Rear Processor

THAT Corporation
 45 Sumner Street
 Milford, MA
 508-478-9200

| | | |
|-------------|-------|---|
| Checked: | Date: | Title: DCM-2/DCM-3 Monitor Board Amp Monitor Mix (HI, MID, SW) |
| Proj. Eng.: | Date: | |
| Chf. Eng.: | Date: | Size: B Drawing Number: 330313 Revision: 01 |
| Production: | Date: | Date: 19-Sep-2002 Drawn by: CMH Sheet 10 of 13 File: F:\DM\SH\SH004051gp\CUR_China_REV\313-01011.DDB - Documents\313-1 |

This document and the data disclosed herein or herewith is not to be reproduced, used, or disclosed in whole or in part to anyone without the written permission of THAT Corporation.

| Rev | Description | Date | Approved |
|-----|-------------|------|----------|
| | | | |

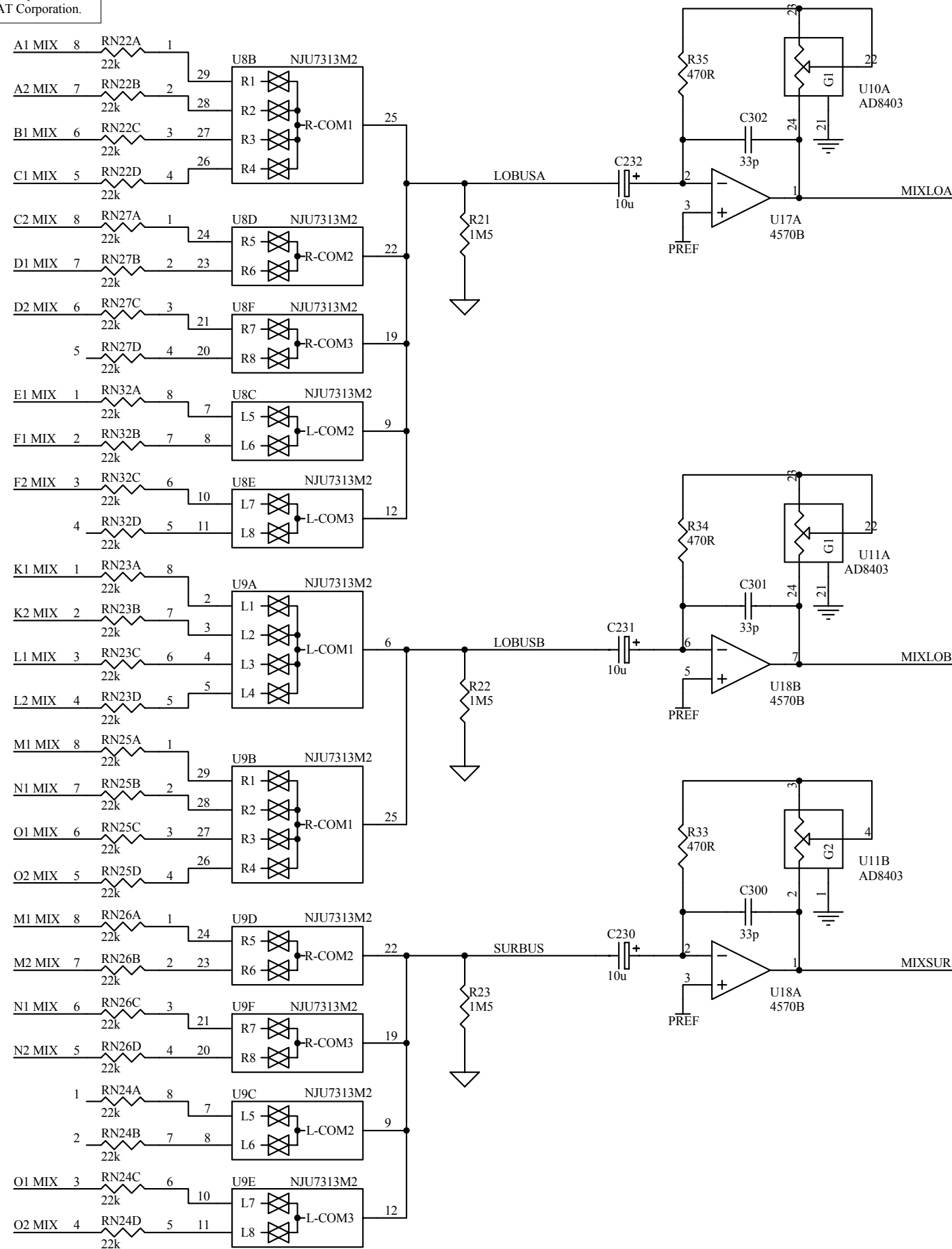

From Dataport VMON Inputs

To Amp Monitor Mix

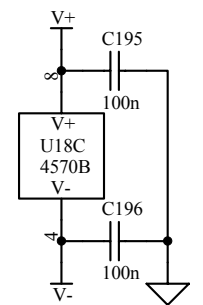
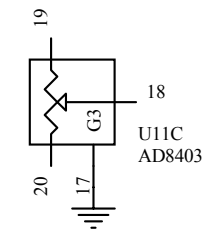
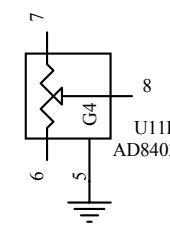

THAT Corporation 45 Sumner Street
Milford, MA
508-478-9200

Title: **DCM-2/DCM-3 Monitor Board**
Amp Monitor Mix (LO, SUR)

| | |
|-------------|-------|
| Checked: | Date: |
| Proj. Eng.: | Date: |
| Chf. Eng.: | Date: |
| Production: | Date: |

| | | |
|---|-------------------------------|---------------------|
| Size: B | Drawing Number: 330313 | Revision: 01 |
| Date: 19-Sep-2002 | Drawn by: CMH | Sheet 11 of 13 |
| File: F:\DM\SH\SH004051gp\CUR China REV\313-01011.DDB - Documents\313-1 | | |

This document and the data disclosed herein or herewith is not to be reproduced, used, or disclosed in whole or in part to anyone without the written permission of THAT Corporation.

| Rev | Description | Date | Approved |
|-----|-------------|------|----------|
| | | | |

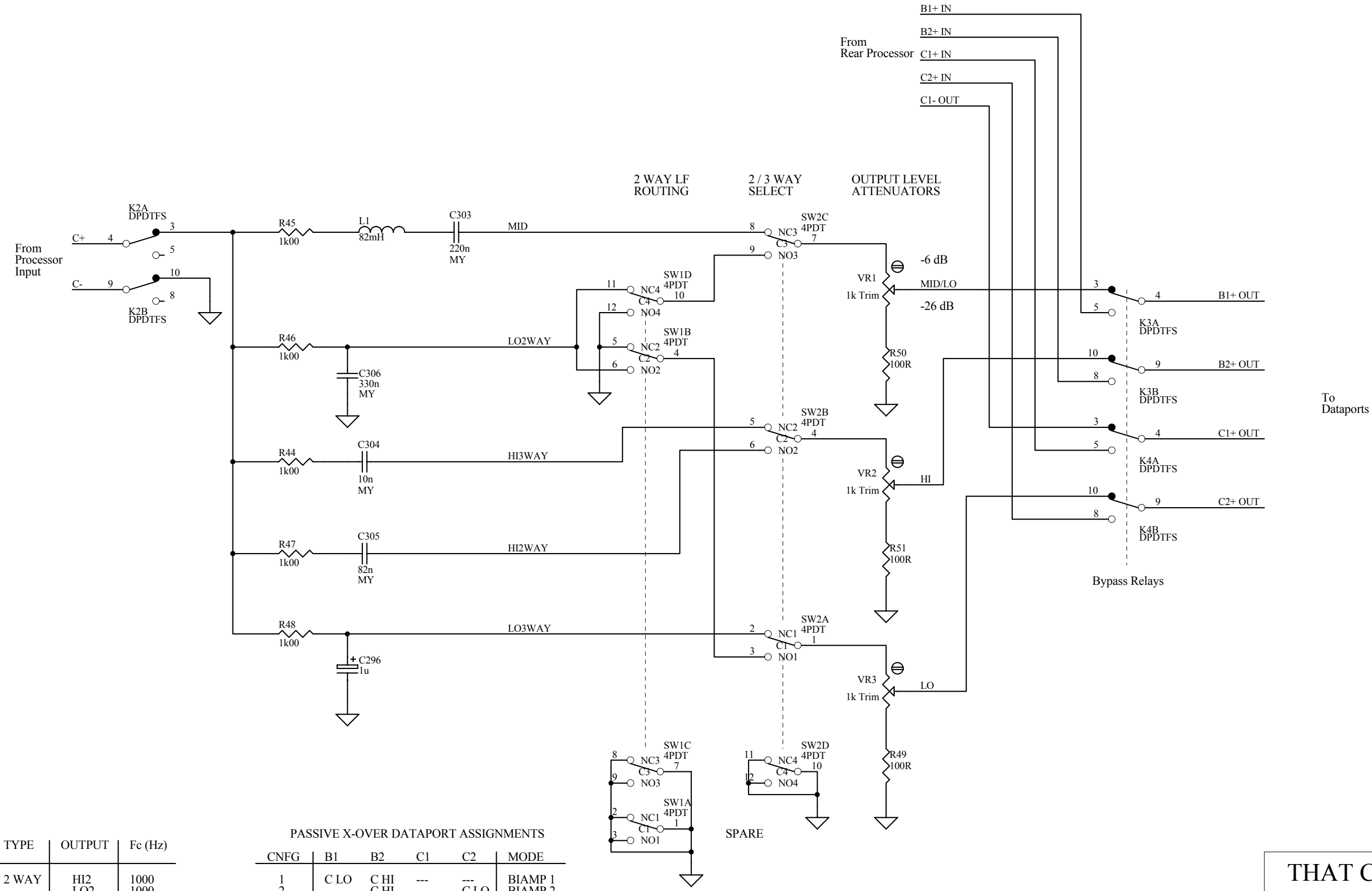

| TYPE | OUTPUT | Fc (Hz) |
|-------|--------|---------|
| 2 WAY | HI2 | 1000 |
| | LO2 | 1000 |
| 3 WAY | HI3 | 5000 |
| | MID3 | 5000 |
| | MID3 | 300 |
| | LO3 | 300 |

| PASSIVE X-OVER DATAPORT ASSIGNMENTS | | | | | | |
|-------------------------------------|-------|------|-----|------|---------|--|
| CNFG | B1 | B2 | C1 | C2 | MODE | |
| 1 | C LO | C HI | --- | --- | BIAMP 1 | |
| 2 | --- | C HI | --- | C LO | BIAMP 2 | |
| 3 | C MID | C HI | --- | C LO | TRIAMP | |
| 4 | C MID | C HI | --- | C LO | TRIAMP | |
| 5 | C LO | C HI | --- | --- | BIAMP 1 | |
| 6 | C MID | C HI | --- | C LO | TRIAMP | |
| 7 | C MID | C HI | --- | C LO | TRIAMP | |

THAT Corporation 45 Sumner Street
 Milford, MA 508-478-9200

Title: **DCM-2/DCM-3 Monitor Board**
 Center Channel Bypass

| | |
|-------------|-------|
| Checked: | Date: |
| Proj. Eng.: | Date: |
| Chf. Eng.: | Date: |
| Production: | Date: |

| | | |
|---|-------------------------------|---------------------|
| Size: B | Drawing Number: 330313 | Revision: 01 |
| Date: 19-Sep-2002 | Drawn by: CMH | Sheet 12 of 13 |
| File: F:\DM\SH\SH004051gp\CUR China REV\313-01011.DDB - Documents\313-1 | | |

This document and the data disclosed herein or herewith is not to be reproduced, used, or disclosed in whole or in part to anyone without the written permission of THAT Corporation.

| Rev | Description | Date | Approved |
|-----|-------------|------|----------|
| | | | |

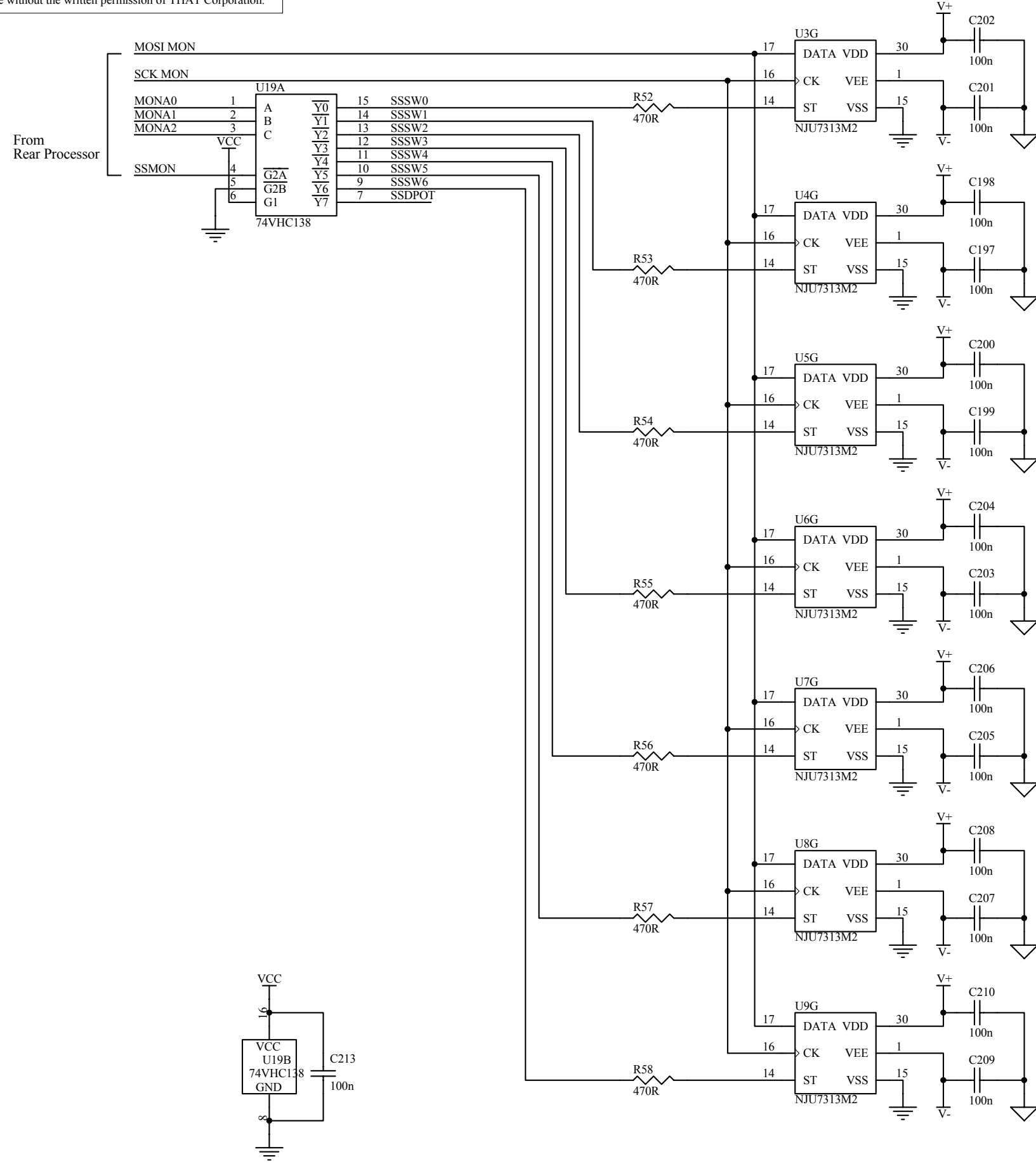

To/From Rear Processor

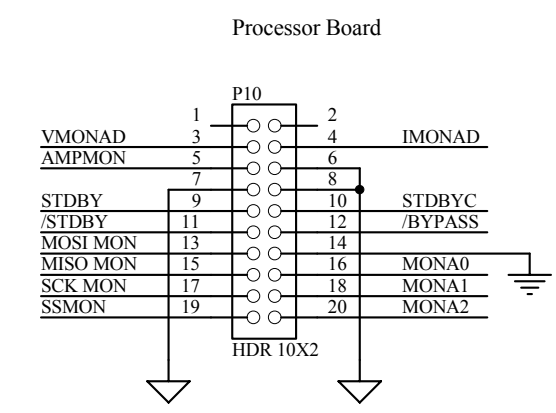
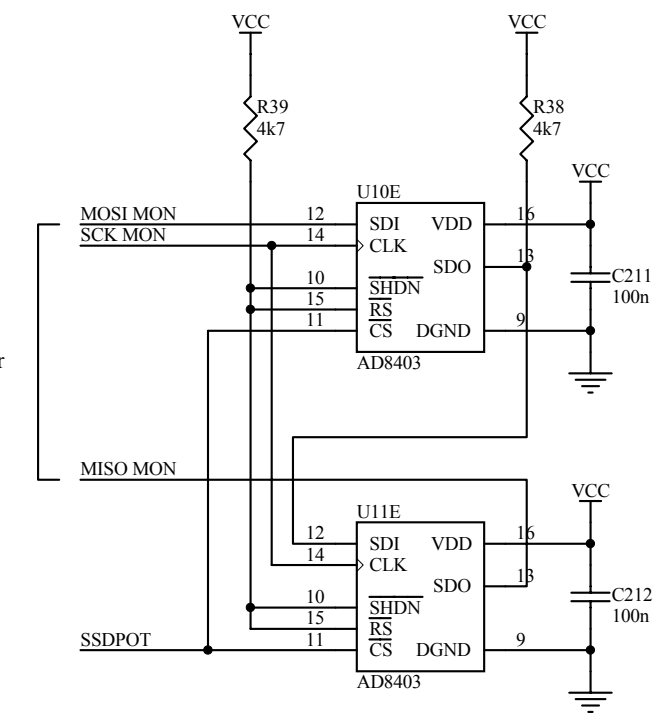

THAT Corporation 45 Sumner Street
Milford, MA 01854
508-478-9200

Title: **DCM-2/DCM-3 Monitor Board**
Analog Switch & Digital Pot Control

| | | | | |
|-------------|-------|---|-------------------------------|---------------------|
| Checked: | Date: | Size: B | Drawing Number: 330313 | Revision: 01 |
| Proj. Eng.: | Date: | Date: 19-Sep-2002 | Drawn by: CMH | Sheet 13 of 13 |
| Chf. Eng.: | Date: | File: F:\DM\SH\SH004051gp\CUR_China_REV\313-01011.DDB - Documents\313-1 | | |
| Production: | Date: | | | |

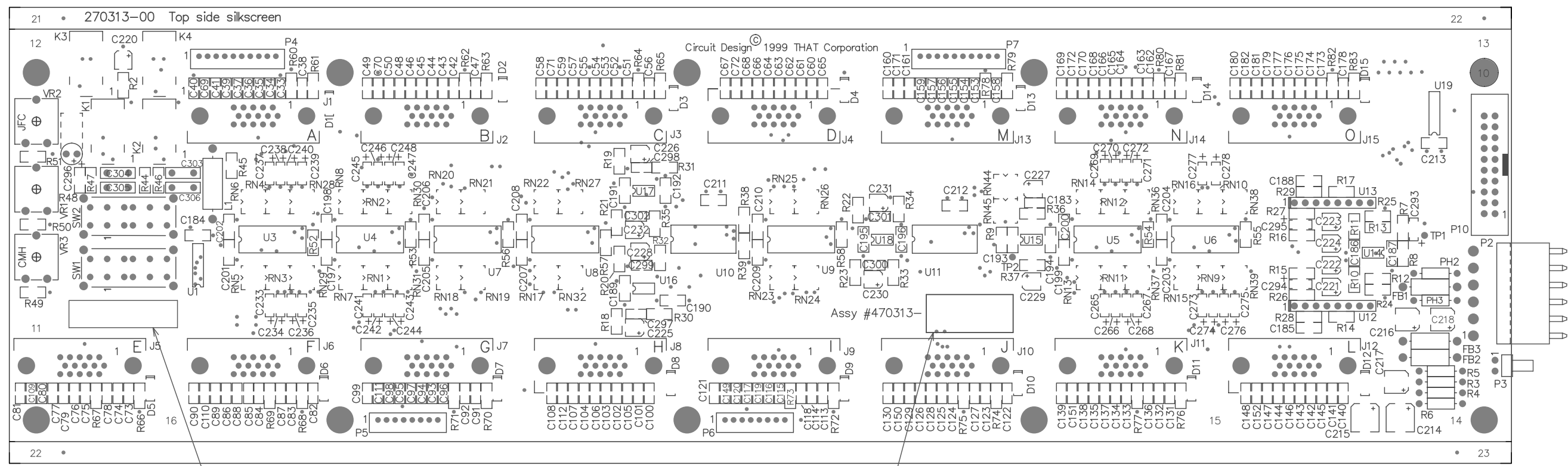

Serial Number Label
See Note 2

Kit Number Label
See Note 2

- Notes:
1. Reference Parts List 370313 (DCM-3) or 370329 (DCM-2).
 2. Attach Kit Number and Serial Number Labels as shown.

| REV | DESCRIPTION | DATE | APP'D |
|-----|-------------|------|-------|
| 01 | Per ECO 197 | 8/99 | |

THIS DOCUMENT AND THE DATA DISCLOSED HEREIN OR HEREWITH IS NOT TO BE REPRODUCED, USED, OR DISCLOSED IN WHOLE OR IN PART TO ANYONE WITHOUT THE WRITTEN PERMISSION OF THAT CORP.

| RELEASED | | | |
|----------|--------|---------|--------|
| DRWN | DATE | PJ. ENG | DATE |
| JFC | 4/5/99 | CMH | 7/7/99 |
| CHK'D | DATE | CH ENG | DATE |
| | | GKH | 7/7/99 |

UNLESS OTHERWISE SPECIFIED ALL DIMENSIONS ARE IN INCHES AND/OR MILLIMETERS (mm)
TOLERANCES ON INCHES
.XX+/-0.15 .XXX+/-0.05
TOLERANCES ON MILLIMETERS
(X)+/-0.4mm (XX)+/-0.13mm
ANGLE +/-0.5 FRACTIONS +/-1/32

TITLE:
Printed Circuit Board
Assembly Drawing
DCM-2/3 Monitor

| | | |
|---------------------------------------|-------------------|-----------|
| THAT Corporation Milford, MA 01757 | | |
| SIZE B | DWG NO. 470313 | REV 01 |
| SCALE: None | SHEET 1 OF 1 | |