

RaneNote 140**Mix-Minus Speech
Reinforcement with
Conferencing**

- **Controlling Acoustic Levels**
- **Speech Reinforcement Zones**
- **Using Delays to Enhance the Sound System**
- **ECS with Zones –**
 - **Two Zone Mix-Minus using the Aux Out of the ECM 82**
 - **Six Zone Mix-Minus using the Post-Gate Outputs of the ECM 82**
- **Applying NAG in the Real World**
- **Noise Masking**
- **Feedback Eliminator**

Mike Slattery
Rane Corporation

© 1997 Rane Corporation

INTRODUCTION

Large conference rooms require speech reinforcement so people at all locations can adequately hear each other. To perform speech reinforcement without acoustic feedback is difficult, add Conferencing and it becomes complex. This RaneNote gives insight into acoustic proprieties of speech reinforcement and applications using Rane Conferencing products.

Controlling Acoustic Levels

The following operations neglect any effect of room echo or room acoustics.

Terms used for calculating properties:

- D0** - Distance from talker to the farthest listener.
- D1** - Distance from the source mic to the nearest loudspeaker.
- D2** - Distance from the listener to the nearest loudspeaker.
- Dn** - Distance from the talker to the nearest listener.
- Ds** - Distance from the talker to the microphone.
- NOM** - Number of Open Mics

When audio travels from a source, its *Sound Pressure Level* (SPL) attenuates by half for every doubling of the distance. The formula for calculating the SPL attenuation is known as the inverse square law and is stated as:

Without speech reinforcement.

Inverse Square Law:

$$\text{SPL Attenuation} = \text{Dn SPL} - 20\text{Log}(\text{D0}/\text{Dn})$$

When applying sound reinforcement to a large conference room, first you need to know the room's *Potential Acoustic Gain* (PAG). This allows you to determine the maximum amount of sound reinforced, in decibels, achievable before feedback occurs.

The PAG formula:

$$\text{PAG} = 20\text{Log}((\text{D0} * \text{D1})/(\text{Ds} * \text{D2}))$$

If **NOM** is greater than 1 then:

$$\text{PAG} = 20\text{Log}((\text{D0} * \text{D1})/(\text{D2} * \text{Ds})) - 10\text{Log}\text{NOM}$$

When using PAG to setup system gain, it is customary to add 6 dB of *Feedback Stability Margin* (FSM). Systems that operate at 6 dB below their PAG are usually free of feedback problems.

$$\text{PAG} = 20\text{Log}((\text{D0} * \text{D1})/(\text{D2} * \text{Ds})) - 10\text{Log}\text{NOM} - 6 \text{ dB}$$

How much sound reinforcement is needed to achieve an average SPL at a distant listener's position relative to the non-reinforced SPL at a near listener's position?

This *Needed Acoustical Gain* or NAG is the gain in decibels required by sound reinforcement to achieve an equivalent acoustic level at the farthest listener equal to what the nearest listener would hear without sound reinforcement.

The NAG formula:

$$\text{NAG} = 20\text{Log}(\text{D0}/\text{Dn})$$

NAG must be less than or equal to PAG to avoid feedback.

Example:

- D0** - 20 feet
- D1** - 10 feet
- D2** - 6 feet
- Dn** - 4 feet
- Ds** - 2 feet

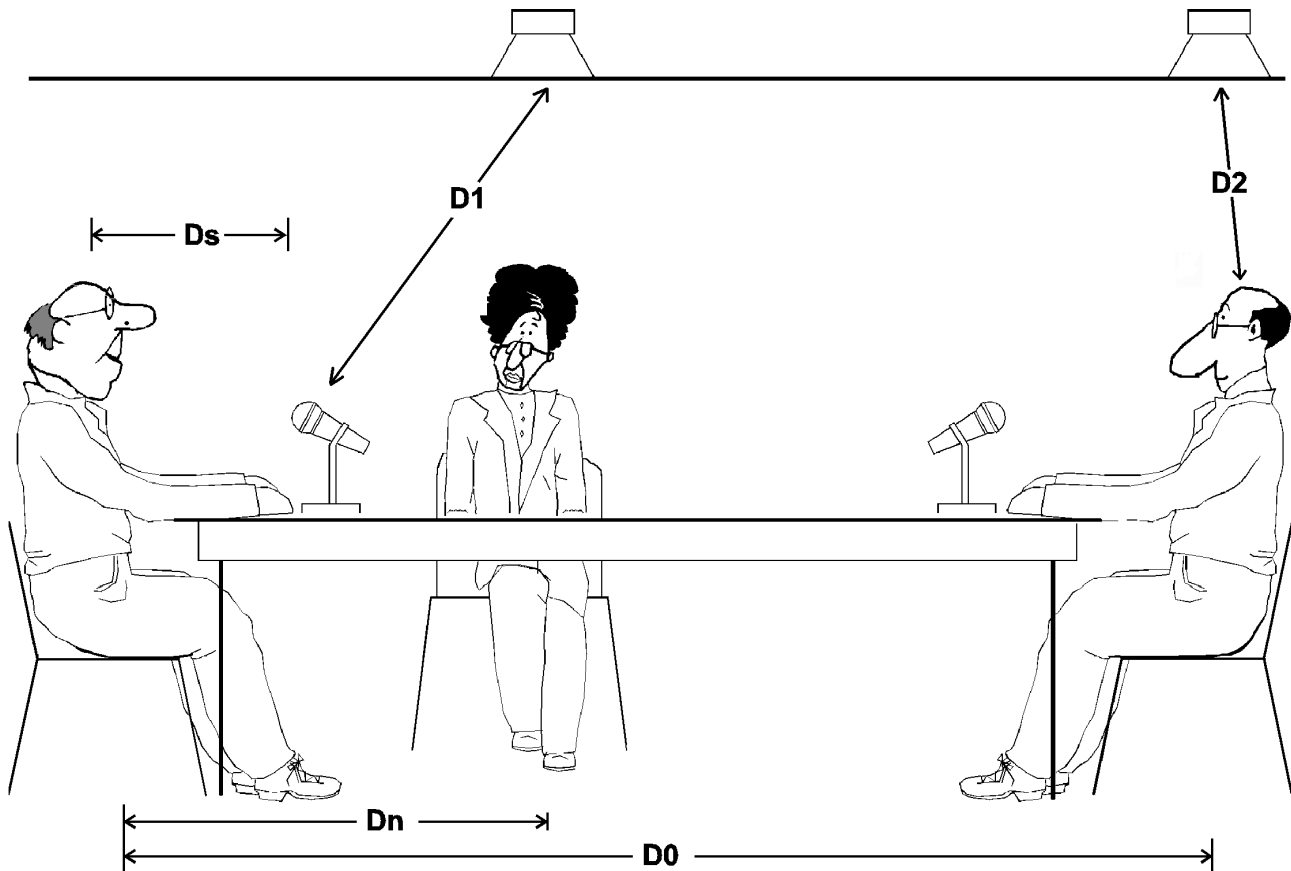

Figure 1. PAG and NAG

Calculating PAG and NAG

Loudspeakers are placed throughout the conference room. The closest loudspeaker to the talker is placed 10 feet from the talker's microphone. The closest loudspeaker to the farthest listener is placed 6 feet from the listener.

1. How much acoustic gain can the sound system supply without causing feedback if only 1 microphone is on? (PAG)
2. How much acoustic gain is required for the farthest listener to hear at an equivalent level to the nearest listener? (NAG)
3. Can the farthest listener receive enough gain without feedback?

1. Using the PAG formula:

$$\text{PAG} = 20\text{Log}((\text{D0} * \text{D1})/(\text{D2} * \text{Ds})) - 10\text{LogNOM} - 6 \text{ dB}$$

$$\text{PAG} = 20\text{Log}((20*10)/(6*2)) - 6 \text{ dB}$$

$$\text{PAG} = 18 \text{ dB (to nearest whole dB)}$$

2. Using the NAG formula:

$$\text{NAG} = 20\text{Log}(\text{D0}/\text{Dn})$$

$$\text{NAG} = 20\text{Log}(20/4)$$

$$\text{NAG} = 14 \text{ dB}$$

3. Since PAG is the maximum calculated level that is obtainable without feedback and it is 4 dB greater than the calculated NAG level, the sound system should operate without feedback.

Speech Reinforcement Zones

To perform speech reinforcement in a large conference room or auditorium, it is best to use automatic microphone mixers and divide the room into zones. The zones are made up of both microphone and loudspeaker groups. A microphone group is a mix of the post-gate outputs from the individual microphones within a zone. Each loudspeaker group has its own amplifier to allow selective audio sources to be played within a zone. Grouping microphones within a zone allows a microphone group to be played at selected loudspeaker groups. Zoning allows microphones within a zone to be played on loudspeakers of other zones while disabling them from being played within their own zone. This is typically called a *mix-minus* zone system.

Some system designers use relays to disable a loudspeaker group when a microphone within its zone gates-on. *Do not use this type of design with acoustic echo cancellers.* Changes in the acoustic properties of a room, caused by switching loudspeakers, will cause the echo canceller to lose its adaptation and return echo.

The simplest example of using zones for speech reinforcement uses only two zones, with each zone having one microphone and one ceiling loudspeaker. A microphone and ceiling loudspeaker are placed at each end of a conference table. Zone 1 contains the left microphone and ceiling loudspeaker and Zone 2 contains the right microphone and ceiling loudspeaker. To perform speech reinforcement, Zone 1's microphone's audio signal is fed only to Zone 2's ceiling loudspeaker and Zone 2's microphone's audio signal is fed only to Zone 1's ceiling loudspeaker.

Using Delays to Enhance the Sound System

Sound travels through 70° F air at about 1.13 feet per millisecond. In a large conference room using speech reinforcement, this delay causes the listener to perceive the direction of the talker from the ceiling loudspeakers and not directly from the talker. This delay-related phenomena is one aspect of the *Haas Effect* or *precedence effect*.

The Haas Effect is described as:

When two loudspeakers are referenced with the same signal, the sound image direction is centered between the two loudspeakers. As one of the loudspeakers is delayed up to 10 milliseconds, the sound image direction is shifted towards the non-delayed loudspeaker. For the sound image to be restored to the center position, the delayed loudspeaker level must be increased by 10 dB. Increasing the level of the delayed loudspeaker also adds to the loudspeakers SPL. If the delay is between 10 to 30 milliseconds, the delayed loudspeaker contributes a sense of liveliness but not direction. Increasing the delay by 50 milliseconds or more causes the listener to become aware of the delayed loudspeaker.

By utilizing the Haas Effect in a speech reinforcement system, the sound image direction is maintained from the talker and not the loudspeakers. This is achieved by using delays in the sound system to align each microphone group to its reinforcement zone. To determine the amount of delay required between each microphone group and its loudspeaker groups, measure the distance from the center talker of one microphone group to each center listener of the zones that the

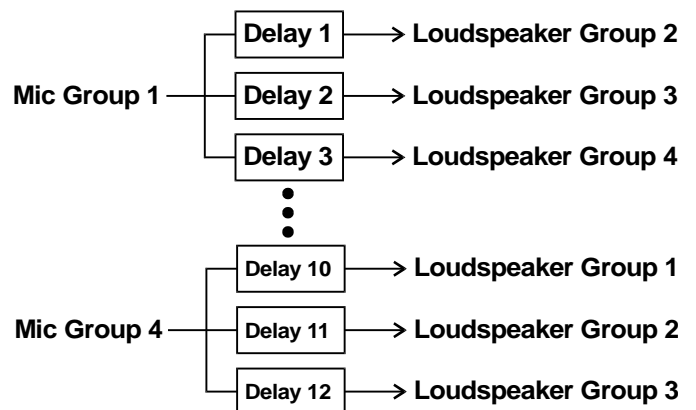
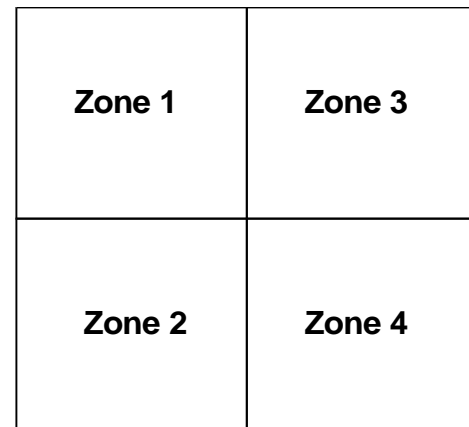

Figure 2. Delays

talkers microphone is reinforced. Add to the measurement the distance from the listener to his closest loudspeaker. Using the measured distance for each zone, calculate the delay and add 10 milliseconds (See above formula). Apply the calculated delay time to each zone for the microphone group. *The number of delays required to perform this task is staggering for a large number of zones.* For example, a system with four zones may require three delays per zone (a delay for each microphone group within a zone) for a total of twelve delays!

Another method for aligning a microphone group to a zone is to use programmable delays for each zone and speech detection for each microphone group. For this to work, the programmable delay must have fast recallable memories without producing audio artifacts during delay changes. Each delay must have a memory setting stored for each microphone group. When speech is detected within a microphone group, all delays must recall their setting for that group. This type of system is achievable with ECS and the RPM 26v by using the contact closure outputs on the ECM 82 mixer and programmable delays available in the RPM 26v.

ECS with Zones

ECS provides three methods for creating microphone groups within a zone. In choosing the type of method, first determine the number of microphones within a zone to create the microphone group. If a microphone group can be placed on one ECM 82, then the Mix or Aux output of an ECM 82 can be used to create the microphone group. If a single microphone group cannot be produced from one ECM 82 mixer, then the Post-Gate Output of an ECM 82 must be used with a separate matrix mixer to create the microphone group. Using the Mix output of the ECM 82 provides for a Mixer Gate feature, which improves system stability. *Unfortunately, if an echo canceller is placed in the ECM 82 then the Mix out has about a 40 millisecond delay.* Therefore, when using an acoustical echo canceller with distances between zones of less than 40 feet, it is not wise to use the Mix out. The **Aux Output** is processed before the echo canceller and only requires the internal Aux Output switch be placed in Post-Gate mode (factory default).

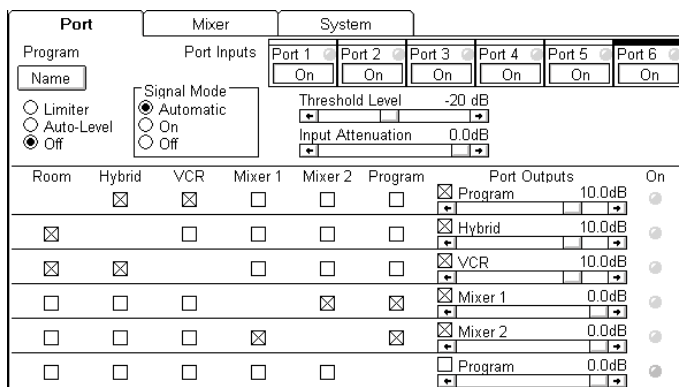

Figure 4. RaneWare ECS Port Screen

Two Zone Mix-Minus Using the ECM8's Aux Out

Figure 3 illustrates how two ECM 82As and an ECB 62 can perform a simple two zone mix-minus system using the Aux out of the ECM 82A and two ports on the ECB 62 to create the zones. This is performed by assigning Mixer 1's Aux output to Zone 2's loudspeakers and Mixer 2's Aux Output to Zone 1's loudspeakers. To play the Program audio (audio from the VCR and Hybrid) at the two zones the audio matrix must include these two inputs. Connecting Port 1's output to Port 6's input allows for the Program Audio level to be changed without changing the speech reinforcement level.

Feedback Warning: Connecting an output port to another input port may result in feedback if the matrix routing is not set properly. (See Fig. 4)

The RPM 26v performs audio processing of the speech reinforcement system. Some of the audio processing features include bandwidth reduction, equalization, delay compensation and compression. DSP program 9 is chosen for its large number of parametric filters. Although this program is normally used as a two-way crossover, its crossovers can be bypassed using the advanced mode by a right mouse click. Placing the RPM 26v between the Aux outputs of the ECM 82As and the ECB 62 allows for audio processing of the speech reinforcement material without affecting the program material. (See Fig. 5)

To create zones:

1. Make a map of the microphone and loudspeaker placements: (See Fig. 3)
2. Divide the table into the number of required zones, or that you are able to work with.
3. Determine which microphones go with each ECM 82A mixer to create a microphone group.
4. Assign the loudspeakers to a zone.
5. Setup the matrix routing for the ECB 62. (See Fig. 4)

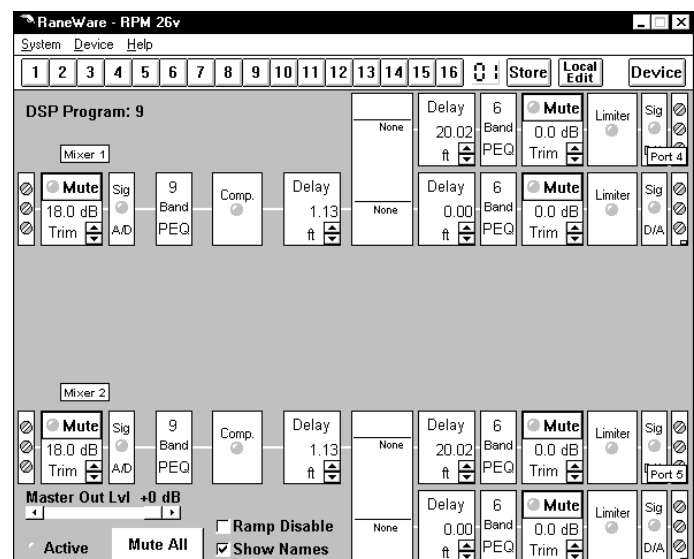

Figure 5. RaneWare RPM 26v DSP Program 9

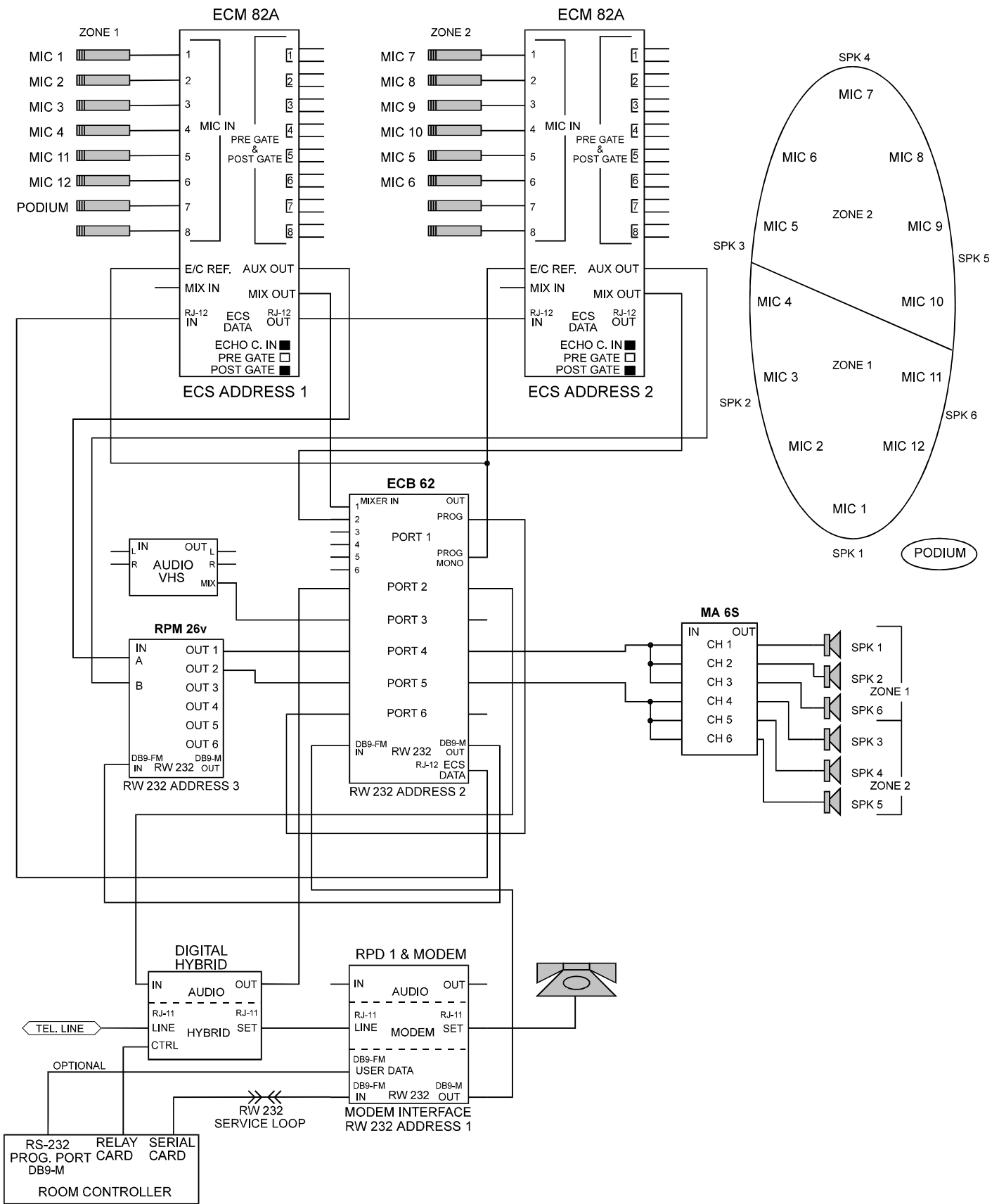

Figure 3. 2-Zone Mix-Minus

Six Zone Mix-Minus Using ECM 82's Post-Gate Outputs

Figure 7 illustrates how the Post-Gate outputs of the ECM 82 are used for speech reinforcement. This system has superior program and speech reinforcement audio performance above the method using the Aux output of the ECM 82A. This improved performance is achieved by using a separate program loudspeaker and a matrix mixer. Separating the program from the speech reinforcement audio allows for audio processing to be performed on the speech reinforcement audio without affecting the program audio.

In this application delays were not required, thereby eliminating the need for microphone grouping. This allows for Post-Gate outputs to be fed directly to a 16 x 8 audio matrix mixer. This mixer is then used to create the speech reinforcement zones using the matrix routing shown in Fig. 6. *Since microphone grouping is not used in this example, performing the Haas Effect with delays is not practical.* Without individual microphone groups the audio received at a zone contains a mix of all of the microphones fed to the loudspeakers for that zone. This will cause problems if delays are used.

Using a matrix mixer in conjunction with the Post-Gate outputs of the ECM 82A reduces the number of microphones in a zone and increases PAG by allowing a greater distance between microphones and loudspeakers. This method also allows for individual NAG level adjustments for each microphone within a Zone. (See Fig 7)

Since there are six zones, three RPM 26v's are used to perform audio processing for the speech reinforcement system. Some of the audio processing features include bandwidth reduction, equalization and compression. DSP program 9 is chosen for its large number of parametric filters. Although this program is normally used as a two-way crossover, its crossovers can be bypassed using the advanced mode with a right mouse click.

To create zones:

1. Make a map of the microphone and loudspeaker placements: (See Fig. 7)
2. Divide the table into the number of required zones, or that you are able to work with.
3. Determine which microphones go with each ECM 82A mixer to create a microphone group.
4. Assign the loudspeakers to a zone.
5. Setup the matrix routing. (See Fig. 6)
6. Setup the NAG level for each input of the Matrix Mixer.

Applying NAG in the Real World

Using the system of Fig. 7, the following procedure describes a method to apply NAG. Since room acoustics is a major contributor of the level settings for PAG and NAG, you

Zone	Speaker	Mic/Input	Input Route
1	1	5, 6, 7, 8, 9, 10, Prog	12, 13, 8, 9, 10, 11, 14
2	2	7, 8, 9, 10, Prog	8, 9, 10, 11, 14
3	3	Pod, 1, 11, 12, Prog	7, 1, 5, 6, 14
4	4	Pod, 1, 2, 3, 4, 11, 12, Prog	7, 1, 2, 3, 4, 5, 6, 14
5	5	Pod, 1, 2, 3, 4, Prog	7, 1, 2, 3, 4, 14
6	6	5, 6, 7, Prog	12, 13, 8, 14

Figure 6. Matrix Routing Chart

Pod = Podium

Prog = Program

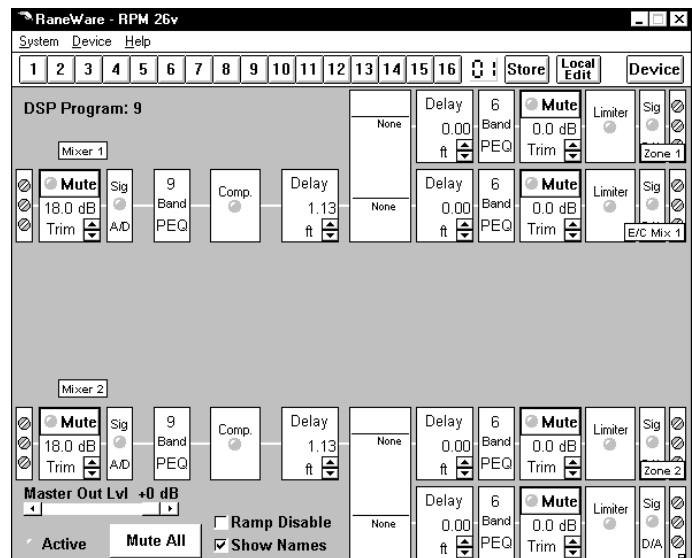

Figure 8. RaneWare RPM 26v DSP Program 9

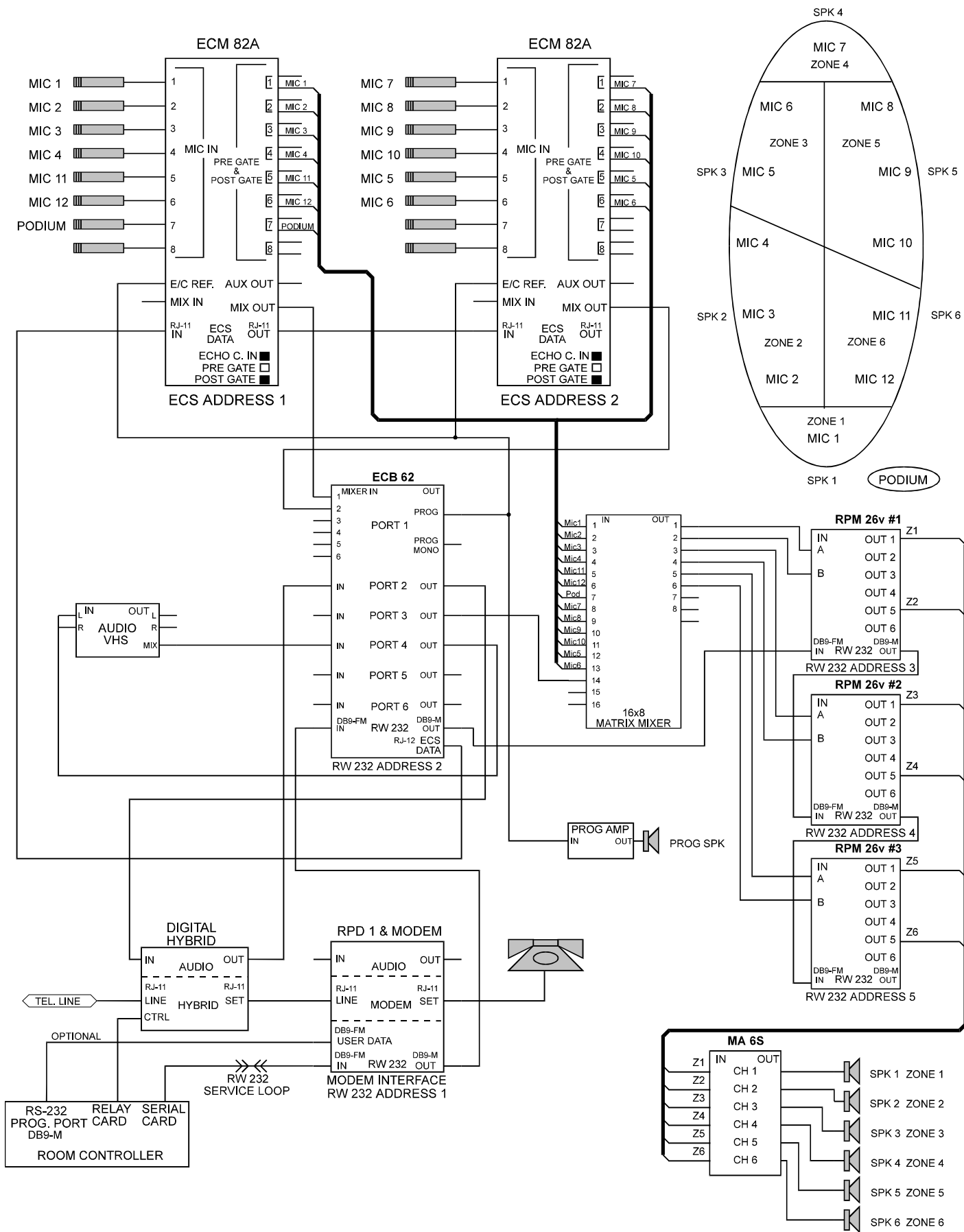

Figure 7. 6-Zone Mix-Minus

might find it easier to set the NAG levels of a microphone to a loudspeaker zones by using a sound level meter and a portable pink noise source with loudspeaker. The following is a step-by-step procedure that first determines a system level set at the power amp using the microphone and loudspeaker that are farthest from each other (**Zr**). This will be the maximum level required by the speech reinforcement system. After determining the system level, the other routing levels for this microphone to a zone (**Zt**) can be set by using a sound level meter or a version of NAG called *Route Attenuation Level* (RAL).

In this system the Podium is 30 feet from the chair at Zone 4 and the microphones are 4 feet apart.

Zr - Distance from noise source to Zone reference.

Zt - Distance from noise source to test zone.

The RAL formula:

$$\text{RAL} = 20\text{Log}(\text{Zt}/\text{Zr})$$

Do not adjust microphone gains at the ECM 82As to set NAG levels.

1. Setup the input levels and equalization for the RPM 26v's.
2. Setup the system level at the MA 6S amp by starting with the microphone that is farthest from a loudspeaker. In this example, the Podium Mic is the farthest from Zone 4's loudspeakers.
 - a. Disable all Mics. *Tip: If you use one of the canned ECS files, Memory 16 can be used to enable and disable Mics.*
 - b. Enable the Podium Mic and apply 80 dB SPL of pink noise source to it. *Tip: If you use one of the canned ECS files, Memory 16 can be used to set this level.*
 - c. Place a sound level meter pointing towards the loudspeaker at the listening position for the person at Mic 7.
 - d. Set the route level for the Podium Mic to Zone 4 (matrix mixer input 7 to output 4) to 0 dB.
 - e. Set the system level by adjusting Zone 4's loudspeaker level at channel 4 of the MA 6S Amp so that 71 dB SPL is received at this position. Set all other MA 6S input levels to the same.
3. Using this Mic, setup the NAG for its next closest zone.
 - a. Place a sound level meter pointing towards the loudspeaker at the listening position for the person in the center of this zone.

- b. Set the route attenuation level for this Mic to the Zone under test using its calculated value or use a sound level meter.

Calculating RAL for the Podium Mic to Zone 3:

$$\text{Zr} = 32 \text{ feet}$$

$$\text{Zt} = 22 \text{ feet}$$

$$\text{RAL} = 20\text{Log}(22/32)$$

$$\text{RAL} = 3 \text{ dB}$$

4. Repeat step 3 for all remaining zones that this Mic is reinforced in. Use the Routing Chart of Fig. 6.
5. Apply the noise source on the next test Mic.
 - a. At the farthest zone, place a sound level meter pointing towards the loudspeaker at the listening position for the person in the center of this zone.
 - b. Set the route level for this Mic for a 71 dB SPL.
 - c. Go to step 3.
6. Repeat step 5 for all remaining Mics.

Noise Masking

Providing a method for noise masking allows individuals to talk "off-record" without being easily heard by others in the room. This method is commonly used in courtroom applications. Since noise masking may need to be selected in different areas, use a matrix mixer to select the masked zones. The noise source on the ECB 62 is program-selectable for this function.

Feedback Eliminator

Installing feedback eliminators at each loudspeaker group can help maintain system stability by reducing feedback. The typical feedback eliminator performs this function using high-Q adaptable notch filters. When using feedback eliminators with echo cancellers, bypass the far-end audio around the feedback eliminator. If the feedback eliminator cannot be bypassed, connect the output of the feedback eliminator to the echo canceller's reference on the ECM 82.

Reference

Glen M. Ballou, *Handbook for Sound Engineers Second Edition* (SAMS, 1991)