

ECO# INCLUDED ON THIS SCHEMATIC/PCB REVISION		
ECO NO:	DATE:	DESCRIPTION:
	6/15/00	Changed wire colors in silkscreen No schematic changes between Rev.B & C

NEED TO CONNECT SET_MUTE

HEADPHONE CIRCUITRY

HEADPHONE OUTPUT

STEREO

Headphones	OUT	IN	OUT	IN	OUT	IN	OUT	IN
Stereo	IN	IN	OUT	OUT	IN	IN	OUT	OUT
Input	OUT	OUT	OUT	OUT	IN	IN	IN	IN
HPN	1.80	2.00	2.20	2.50	2.81	3.33	3.91	5.00

COMPANY:	LINE 6	
TITLE:	SPIDER 212 MAIN	
PROGRAM:	PADS POWER LOGIC V3.0	
FILENAME:	G:/Clients/Ffd/Spider 212/Hardware/Schematics/Main/Spdr212 Main Rev C.sch	
SCALE: 1:1	SIZE: C	PART NUMBER: 35-00-0084 PCB 50-00-0084 PCBA
SHEET: 1 OF 3	REV: C	

DRAWN: EVP/GNS	DATED: June 15, 2000
CHECKED: INITIALS	DATED: MO Day, Year

6 5 4 3 2 1

D

C

B

A

ECO# INCLUDED ON THIS SCHEMATIC/PCB REVISION		
ECO NO:	DATE:	DESCRIPTION:

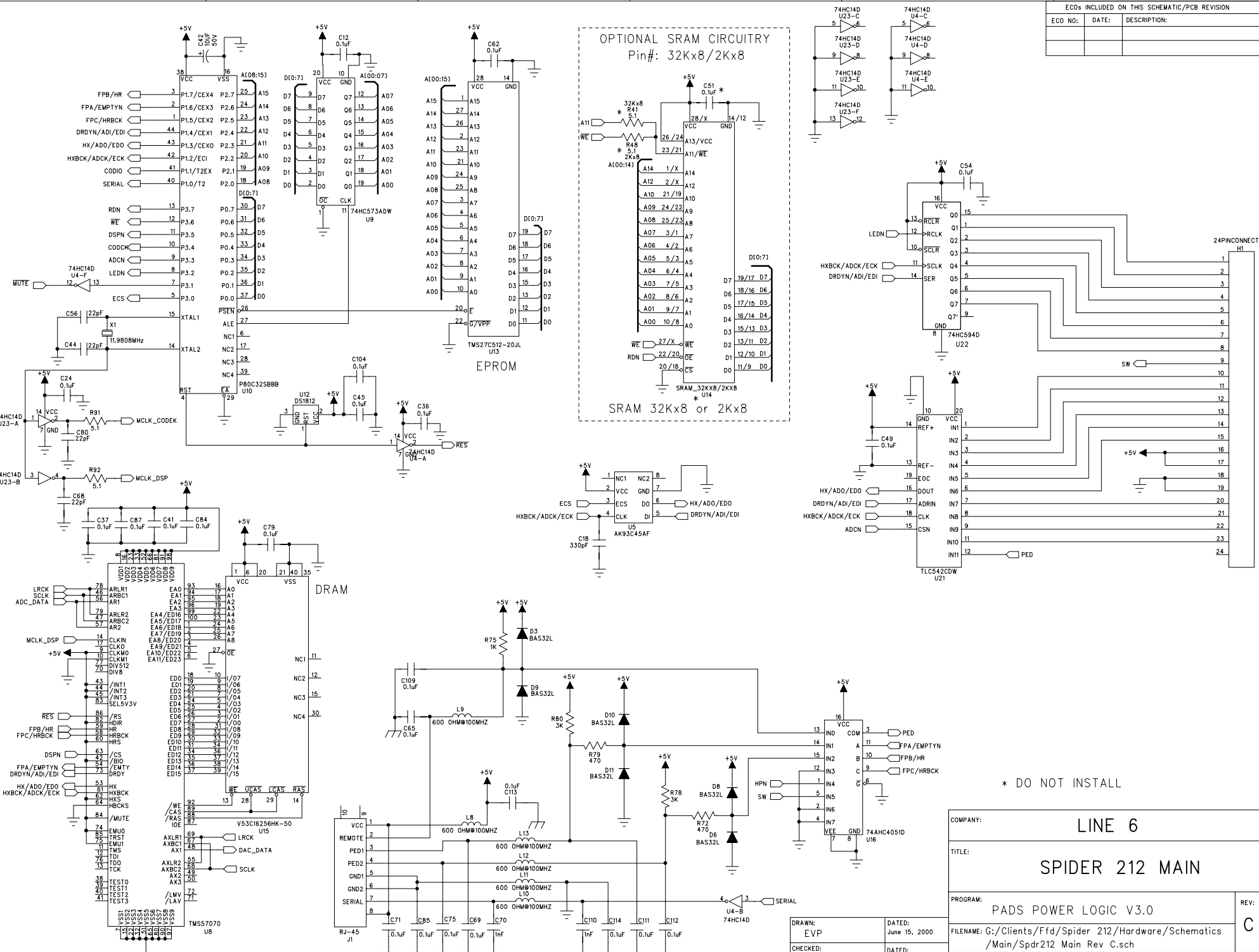

COMPANY:	LINE 6	
TITLE:	SPIDER 212 MAIN	
PROGRAM:	PADS POWER LOGIC V3.0	
FILENAME:	G:/Clients/Frd/Spider 212/Hardware/Schematics/Main/Spdr212 Main Rev C.sch	
SCALE: 1:1	SIZE: C	PART NUMBER: 35-00-0084 PCB 50-00-0084 PCB A
SHEET: 2 OF 3		

DRAWN: EVP	DATED: June 15, 2000
CHECKED: INITIALS	DATED: MO Day, Year

C

6

5

4

3

2

1

POTS ARE BACKWARDS!
MIN: 5V
MAX: 0V

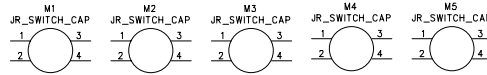
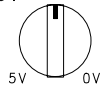

ECOs INCLUDED ON THIS SCHEMATIC/PCB REVISION		
ECO NO:	DATE:	DESCRIPTION:

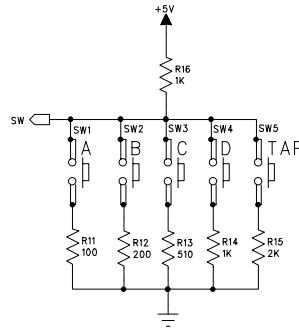
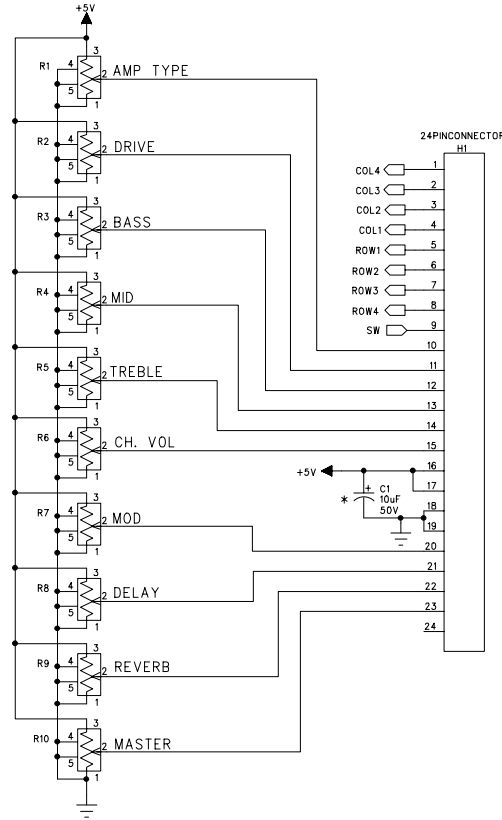

SWITCH	SW1	SW2	SW3	SW4	SW5
VOLTAGE	0.45V	0.83V	1.69V	2.50V	3.33V

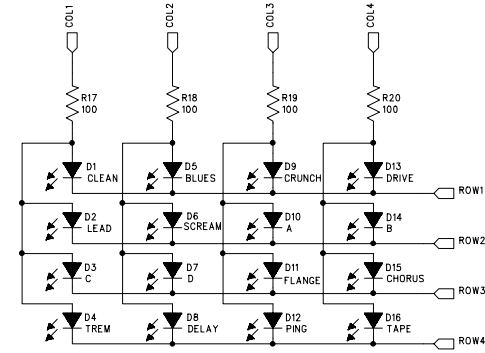

* Do Not Install

COMPANY:	LINE 6		
TITLE:	SPIDER FRONT PANEL BOARD		
PROGRAM:	PADS POWER LOGIC V3.0		REV:
			4
DRAWN:	DATED:	FILENAME:	SCALE: 1:1 SIZE: C PART NUMBER: XX-XX-XXXX SHEET: 1 OF 1
Erik VP	Oct 26, 1999	G:/Clients/Ffd/Spider/PADS/Schematics/Spdr FP Rev4.sch	
CHECKED:	DATED:		
INITIALS	MO Day, Year		

DRAWN:	DATED:
Erik VP	Oct 26, 1999
CHECKED:	DATED:
INITIALS	MO Day, Year

6

5

4

3

2

1

ECO# INCLUDED ON THIS SCHEMATIC/PCB REVISION		
ECO NO:	DATE:	DESCRIPTION:

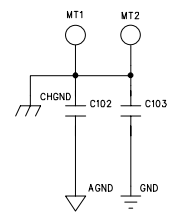
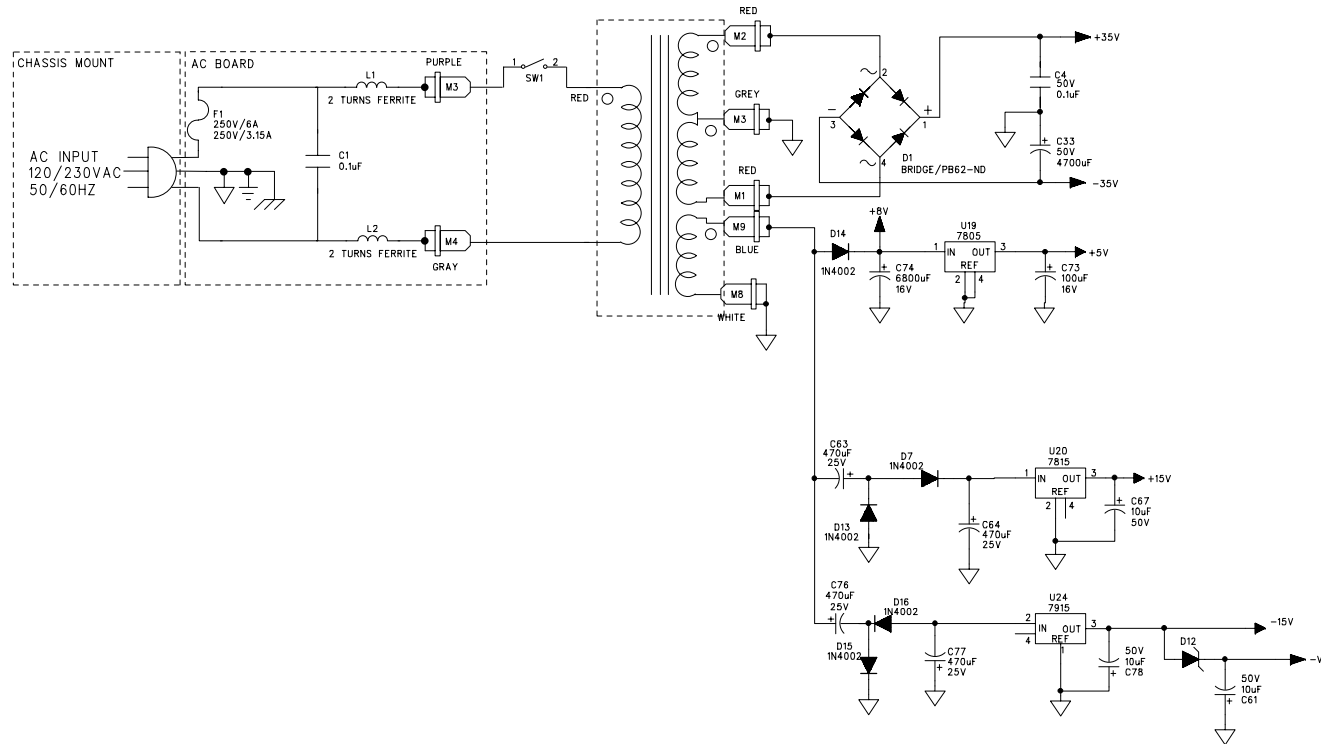

COMPANY:		LINE 6	
TITLE: SPIDER 212 MAIN BOARD			
PROGRAM: PADS POWER LOGIC V3.0			REV: C
FILENAME: G:/Clients/Ffd/Spider 212/Hardware/Schematics /Main/Spdr212 Main Rev C.sch			
SCALE: 1:1	SIZE: C	PART NUMBER: 35-00-0084 PCB 50-00-0084 PCBA	SHEET: 3 OF 3

DRAWN: EVP	DATED: June 15, 2000
CHECKED: Initials	DATED: Date

6

5

4

3

2

1

ECO# INCLUDED ON THIS SCHEMATIC/PCB REVISION		
ECO NO:	DATE:	DESCRIPTION:

NOT MOUNTED ON PCB.
 SOLDER WIRES BETWEEN
 SOCKET AND PCB.

AC INPUT
 120/230VAC
 50/60HZ

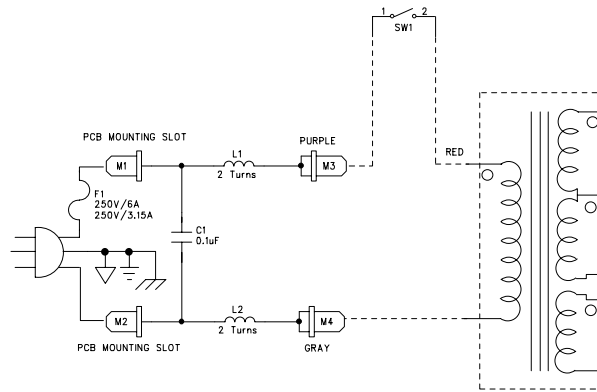

COMPANY:	LINE 6		
TITLE:	SPIDER AC BOARD		
PROGRAM:	PADS POWER LOGIC V3.0		REV: 0
DRAWN: EWE/als	DATED: Sep 23, 1999	FILENAME: Data on Ffd/Clients/Ffd/Bspider/PADS/Karw/Gatien/Sigs/RKQ_Rdr0.sch	
CHECKED: Initials	DATED: Date	SCALE: 1:1	SIZE: C PART NUMBER: XX-XX-XXXX SHEET: 1 OF 1

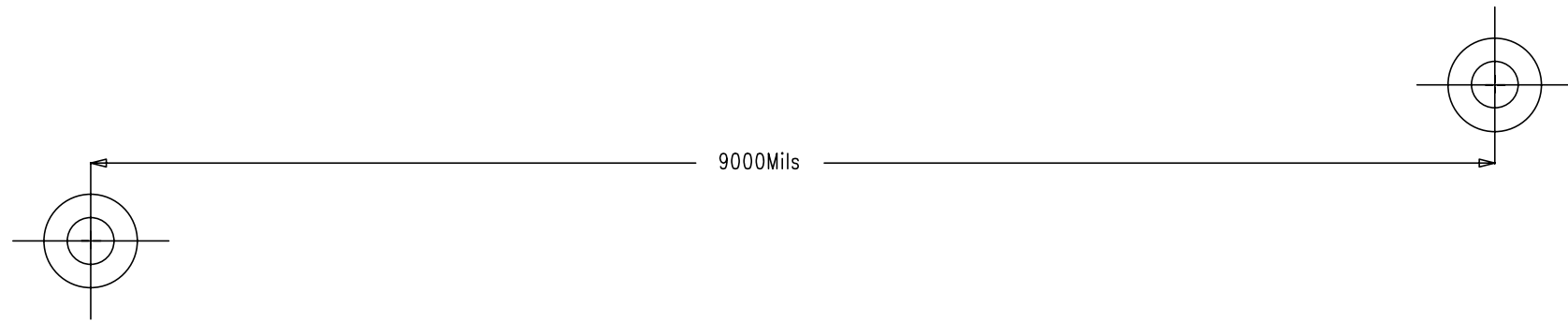

THE INFORMATION CONTAINED IN THIS DRAWING IS THE SOLE PROPERTY OF LINE 6 INC. ANY REPRODUCTION IN PART OR WHOLE WITHOUT THE WRITTEN PERMISSION OF LINE 6 INC. IS PROHIBITED

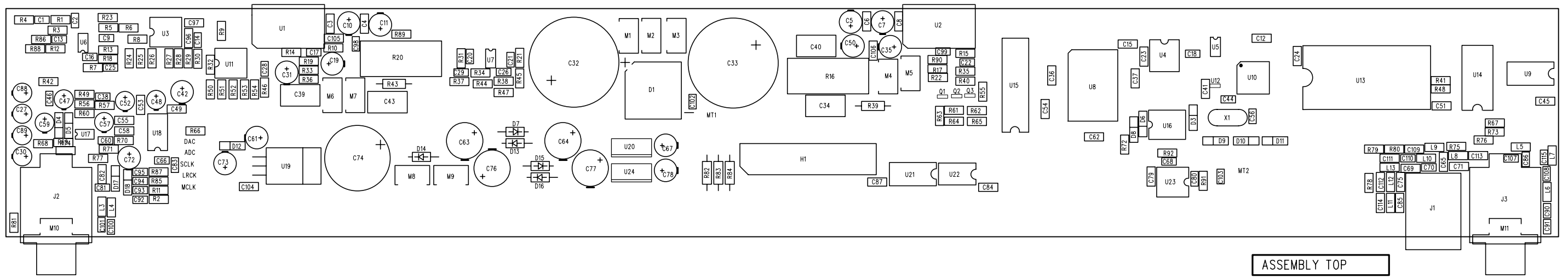

COMPANY:	LINE 6		
PROGRAM:	PADS POWER PCB 3.5.1		
FILE:	G:\CLIENTS\FFD\Spider 212\Hardware\PCB\Main\Rev C\Spider212 Main Rev C.pcb		
SCALE:	1:1	REV:	C
		DATE:	June 15, 2000
TITLE:	Spider 212 Main Board		

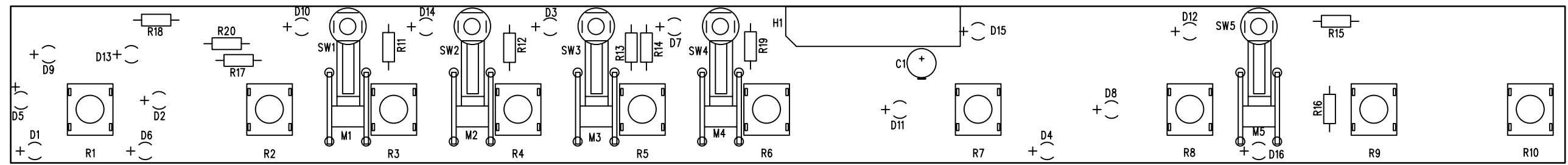

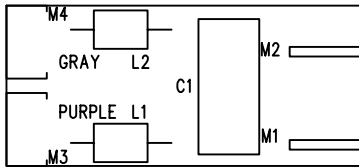

SILKSCREEN TOP

1	170	30-00-0607	SCR 6-32 x 7/16 LG PHILLIPS PN H STL ZINC (W/ LK WASH)	0	EA	.0	A	Y	2.000000
1	180	30-00-0617	Screw, #6 x 7/16" socket cap alloy	0	EA	.0	A	Y	2.000000
1	190	30-00-1014	SCR, 10-32 x 7/8 LG, PHILLIPS PNH, STL, BLK	0	EA	.0	A	Y	8.000000
1	200	30-00-1033	SCR, 10-32 x 3/8 LG, SCH STL, BLK OXIDE	0	EA	.0	A	Y	4.000000
1	210	30-00-1128	SCR, 10-32 x 1 3/4 LG, OVAL ST SK, PHH, STL, BLK	0	EA	.0	A	Y	4.000000
1	220	30-00-1632	SCR, 6-32 x 3/8 LG, PHILLIPS P H, STL, BLK	0	EA	.0	A	Y	4.000000
1	230	30-00-6103	Nut,9MM hex panel,zinc M9-0.75 (Comes with 01-48-6103)	0	EA	.0	A	Y	10.000000
1	240	30-03-0040	INSULATOR, MN#4-5	0	EA	.0	A	Y	2.000000
1	250	30-03-0112	WASHER,FINISHING,FLANGED,NO.10 ,STL,BLK OXIDE	0	EA	.0	A	Y	8.000000
1	260	30-03-0610	Washer, #6 internal lock	0	EA	.0	A	Y	2.000000
1	270	30-06-0440	NUT .242 HEX NO.2 STL ZINC (FOR POWER AMP)	0	EA	.0	A	Y	2.000000
1	280	30-06-0623	6-32 nut w/captive star washer	0	EA	.0	A	Y	1.000000
1	290	30-06-0832	NUT .335 HEX 8-32 STL ZINC W/ TOOTH WASHER	0	EA	.0	A	Y	4.000000
1	300	30-15-4019	BUTTON, MOUNTING, NYLON	0	EA	.0	A	Y	2.000000
1	310	30-24-0003	CABLE TIE Panduit 3 7/8" clear Panduit PLT1M-M	0	EA	.0	A	Y	11.000000
1	320	30-28-0212	Front panel,plastic,Spider212	0	EA	.0	A	Y	1.000000
1	330	30-45-2000	KNOB PLASTIC TAIWAN	0	EA	.0	A	Y	10.000000
1	340	30-51-2212	Chassis, Spider 212	0	EA	.0	A	Y	1.000000
1	350	30-51-6013	HEAT SINK, 4.0 x 3.75 x 1.0, A	0	EA	.0	A	Y	2.000000

1	360	30-60-2080	LOGO LINE 6, Spider	0	EA	.0	A	Y	1.000000
1	370	30-63-0010	INSULATION, VOLARAPOLYOLEFIN F OAM, 26.5 x 1/4 x 1/16	0	EA	.0	A	Y	7.000000
1	380	30-63-1111	FOAM, 1/8" THK, 1/2" SQ, ADH O NE SD, 3M NO. 4508	0	EA	.0	A	Y	2.000000
1	390	40-00-0073	Sheet, Accessory, Domestic	0	EA	.0	A	Y	1.000000
1	400	40-00-0080	Manual, User's, Spider	0	EA	.0	A	Y	1.000000
2	10	40-10-0046T	FOAM, TOP, SPIDER 212	0	EA	.0	A	Y	2.000000
2	20	40-10-0046B	FOAM, BOTTOM, SPIDER 212	0	EA	.0	A	Y	2.000000
1	420	40-10-0082	Carton, Inner - Spider 212	0	EA	.0	A	Y	1.000000
1	430	40-10-0083	Carton, Outer - Spider 212	0	EA	.0	A	Y	1.000000
1	440	40-20-0010	Plastic Bag, 43"x38"x.004, clear	0	EA	.0	A	Y	1.000000
1	450	40-25-0015	Label, Grounding, Pod Pro	0	EA	.0	A	Y	1.000000
1	460	40-25-0020	Label, Quality Inspection	0	EA	.0	A	Y	1.000000
1	470	40-25-0100	Label, Bar Code Serial Number 4 panel label - LTX 16 1125503	0	EA	.0	A	Y	1.000000
1	475	45-00-2212	EPROM, programmed, Spider 212 version 1.0 U13	0	EA	.0	A	Y	1.000000
1	480	50-00-0081	Front PCB ASSY - Spider	0	EA	.0	A	Y	1.000000
2	10	01-12-0101	RES 100R 1/4W 5% DIP TH	0	EA	.0	A	Y	5.000000
2	20	01-12-0102	Ref: R11, R17-R20 RES 1K 1/4W 5% DIP TH	0	EA	.0	A	Y	2.000000
2	30	01-12-0201	Ref: R14, R16 RES 200R 1/4W 5% DIP TH	0	EA	.0	A	Y	1.000000

2	40 01-12-0202	Ref: R12 RES 2.0K 1/4W 5% DIP TH	0 EA	.0	A Y	1.000000
2	50 01-12-0511	Ref: R15 RES 510R 1/4W 5% DIP TH	0 EA	.0	A Y	1.000000
2	60 01-48-6103	Ref: R13 POT 10KB SINGLE 25MM W/9mmNUT D-SHAFT	0 EA	.0	A Y	10.000000
2	70 18-02-0002	LED RED Hi Intensity L34LSRD	0 EA	.0	A Y	16.000000
2	80 21-23-1024	Ref: D1-D16 CAB DIL 24-PIN 2mm 60mm ML-FEM	0 EA	.0	A Y	1.000000
2	90 24-31-1105	TACK SWITCH	0 EA	.0	A Y	5.000000
2	100 30-15-0401	Ref: SW1-SW5 SPC LED .155 O.D. x .600 LG BL K PVC BIVARE ELM5-600 (SPDR)	0 EA	.0	A Y	16.000000
1	490 50-00-0082	AC PCB ASSY - Spider	0 EA	.0	A Y	1.000000
2	10 03-24-0104	CAP 1uF 250V 20% TH METAL FILM-POLY	0 EA	.0	A Y	1.000000
2	20 11-10-2020	Ref: C1 Wide band choke 1-5 turns	0 EA	.0	A Y	2.000000
2	25 21-14-0002	Ref: L1,L2 JACK AC 3-PIN MALE PANEL-MNT SNAP-IN CRJ-45	0 EA	.0	A Y	1.000000
2	30 21-18-0187	9401 Connector,Qck.ConnectPost .187 Amp 63823-1	0 EA	.0	A Y	2.000000
2	35 21-34-1806	Ref: M3,4 Cable Assy, Earthing	0 EA	.0	A Y	1.000000

Ref: Moved from top assy per ECO#9929401 11/22/99

1	500 50-00-0084	Main PCB ASSY - Spider 212	0 EA	.0	A Y	1.000000
2	30 01-04-0101	RES 100R 1/8W 5% 1206 SM	0 EA	.0	A Y	1.000000
2	40 01-04-0102	Ref: R70 RES 1K 1/8W 5% 1206 SM	0 EA	.0	A Y	16.000000
2	50 01-04-0103	Ref: R8,R10,R22,R32,R36,R40,R55,R56,R64,R67,R69,R75,R77,R81,R89 R90 RES 10K 1/8W 5% 1206 SM	0 EA	.0	A Y	19.000000
2	60 01-04-0104	Ref: R1,R3-6,R12-13,R18,R21,R26,R31,R34,R37-38,R44-45,R47,R51,R62 RES 100K 1/8W 5% 1206 SM	0 EA	.0	A Y	1.000000
2	70 01-04-0105	Ref: R57 RES 1M 1/8W 5% 1206 SM	0 EA	.0	A Y	1.000000
2	80 01-04-0150	Ref: R71 RES 15R 1/8W 5% 1206 SM	0 EA	.0	A Y	2.000000
2	90 01-04-0153	Ref: R30,R46 RES 15K 1/8W 5% 1206 SM	0 EA	.0	A Y	3.000000
2	100 01-04-0154	Ref: R14,R35,R60 RES 150K 1/8W 5% 1206 SM	0 EA	.0	A Y	2.000000
2	110 01-04-0183	Ref: R15,R19 RES 18K 1/8W 5% 1206 SM	0 EA	.0	A Y	1.000000
2	120 01-04-0202	Ref: R63 RES 2K 1/8W 5% 1206 SM	0 EA	.0	A Y	3.000000
2	130 01-04-0302	Ref: R9,R24,R73 RES 3K 1/8W 5% 1206 SM	0 EA	.0	A Y	2.000000
2	140 01-04-0331	Ref: R78,R80 RES 330R 1/8W 5% 1206 SM	0 EA	.0	A Y	1.000000
2	150 01-04-0332	Ref: R61 RES 3.3K 1/8W 5% 1206 SM	0 EA	.0	A Y	1.000000
2	160 01-04-0362	Ref: R65 RES 3.6K 1/8W 5% 1206 SM	0 EA	.0	A Y	1.000000

2	170 01-04-0470	Ref: R76 RES 47R 1/8W 5% 1206 SM	0 EA	.0 A Y	8.000000
2	180 01-04-0471	Ref: R25,R27-29,R50,R52-54 RES 470R 1/8W 5% 1206 SM	0 EA	.0 A Y	3.000000
2	190 01-04-0472	Ref: R49,R72,R79 RES 4.7K 1/8W 5% 1206 SM	0 EA	.0 A Y	2.000000
2	200 01-04-0473	Ref: R17,R33 RES 47k 1/8w 5% 1206 SM	0 EA	.0 A Y	1.000000
2	210 01-04-0512	Ref: R66 RES 5.1K 1/8W 5% 1206 SM	0 EA	.0 A Y	8.000000
2	220 01-04-0622	Ref: R2,R7,R11,R23,R85-88 RES 6.2K 1/8W 5% 1206 SM	0 EA	.0 A Y	1.000000
2	230 01-12-0027	Ref: R74 RES 2.7R 1/4W 5% DIP TH	0 EA	.0 A Y	2.000000
2	240 01-20-5033	Ref: R39,R43 RES 0.33R 5W 5% DIP TH	0 EA	.0 A Y	2.000000
2	250 03-10-0331	Ref: R16,R20 CAP 330uF 10V 20% RAD ELEC TH	0 EA	.0 A Y	1.000000
2	260 03-12-0107	Ref: C72 CAP 100uF 16V 20% RAD ELEC TH	0 EA	.0 A Y	1.000000
2	270 03-12-0688	Ref: C73 CAP 6800uF 16V 20% RAD ELEC TH	0 EA	.0 A Y	1.000000
2	280 03-14-0477	Ref: C74 CAP 470uF 25V 20% RAD ELEC TH	0 EA	.0 A Y	4.000000
2	290 03-18-0105	Ref: C63-64,C76-77 CAP 1uF 50V 20% RAD ELEC TH	0 EA	.0 A Y	9.000000
2	300 03-18-0106	Ref: C27,C30,C47-48,C52,C57,C59,C88-89 CAP 10uF 50V 20% RAD ELEC TH	0 EA	.0 A Y	12.000000

Ref: C5,C7,C10-11,C19,C31,C35,C42,C50,C61,C67,C78

2	310 03-18-0478	CAP 4700uF 50V 20% RAD ELEC TH	0 EA	.0 A Y	2.000000
		Ref: C32-33			
2	320 03-36-0224	CAP 0.22uF 50V 20% ESTR TH	0 EA	.0 A Y	4.000000
		Ref: C34,C43,C39-40			
2	330 03-45-0473	CAP 47nF 16V 20% 1206 FILM SM	0 EA	.0 A Y	1.000000
		Ref: C82			
2	340 03-46-0104 X7R	CAP 0.1uF 50V 20% 1206 SM	0 EA	.0 A Y	36.000000
		Ref: C3-4,C6,C8,C12,C15,C23-24,C36-37,C41,C45,C49,C53-55,C58,C62, C65,C69,C71,C75,C79,C84-85,C87,C96-97,C104-106,C109,C111-114			
2	350 03-52-0101 X7R 08055A101KATMA	CAP 100 pF 50V 20% 0805 SM	0 EA	.0 A Y	1.000000
		Ref: C101			
2	360 03-52-0102 X7R	CAP 1nF 50V 20% 0805 SM	0 EA	.0 A Y	17.000000
		Ref: C17,C20-22,C26,C29,C38,C46,C70,C92-95,C98-100,C110			
2	370 03-52-0103 X7R	CAP 10nF 50V 20% 0805 SM	0 EA	.0 A Y	1.000000
		Ref: C60			
2	380 03-52-0220 X7R	CAP 22pF 50V 20% 0805 SM	0 EA	.0 A Y	4.000000
		Ref: C44,C56,C68,C80			
2	390 03-52-0221 X7R	CAP 220pF 50V 20% 0805 SM	0 EA	.0 A Y	15.000000
		Ref: C1-2,C9,C13,C16,C25,C81,C86,C90-91,C102-103,C107-108,C115			
2	400 03-52-0331 X7R	CAP 330pF 50v 20% 0805 SM	0 EA	.0 A Y	1.000000
		Ref: C18			
2	410 03-52-0472 X7R	CAP 4700pF 50V 20% 0805 SM	0 EA	.0 A Y	2.000000
		Ref: C14,C28			
2	420 03-52-0562 X7R	CAP 5.6nf 50V 20% 0805 SM AVX 08051C562KATMA	0 EA	.0 A Y	2.000000
		Ref: C66,C83			
2	430 06-04-4002	DIODE POWER 1N4002 TH	0 EA	.0 A Y	5.000000
		Ref: D7,D13-16			
2	440 06-16-6200 AY-PB64	DIODE BRIDGE-RECTIFIER TH VISH	0 EA	.0 A Y	1.000000
		Ref: D1			
2	450 06-20-4148	DIODE SMALL-SIGNAL 4148 DL-35	0 EA	.0 A Y	8.000000

2	460	06-28-0310	Ref: D3-6,D8-11 DIODE ZENER 3.3V DL-35 SM PHIL LIPS-L5226B	0	EA	.0	A	Y	2.000000
2	470	06-28-0820	Ref: D17-18 DIODE ZENER 8.2V DL-35 SM	0	EA	.0	A	Y	1.000000
2	480	09-10-4401	Ref: D12 TRANS NPN SMALL-SIGNAL 2N4401 SM	0	EA	.0	A	Y	1.000000
2	490	09-10-4403	Ref: Q1 TRANS PNP SMALL-SIGNAL 2N4403 SM	0	EA	.0	A	Y	2.000000
2	500	11-00-1198	Ref: Q2-3 Crystal Osc 11.98080MHz HC-49/u holder	0	EA	.0	A	Y	1.000000
2	510	11-10-0601	Ref: X1 BEAD FERRITE 600R @100mHZ SM 1206	0	EA	.0	A	Y	11.000000
2	520	12-02-7805	Ref: L3-13 IC REG +5v 1.5 Amp TH	0	EA	.0	A	Y	1.000000
2	530	12-02-7815	Ref: U19 IC REG +15V 1AMP TH	0	EA	.0	A	Y	1.000000
2	540	12-02-7915	Ref: U20 IC REG -15V 1AMP TH	0	EA	.0	A	Y	1.000000
2	550	12-30-3886	Ref: U24 IC POWER-AMP 50W LM3886TF TH	0	EA	.0	A	Y	2.000000
2	560	12-54-0072	Ref: U1-2 IC OP-AMP DUAL TL072D SM	0	EA	.0	A	Y	3.000000
2	570	12-54-0084	Ref: U6-7,U17 IC OP AMP Quad TL084CD SM mfg p/n# TL084CD	0	EA	.0	A	Y	2.000000
2	580	12-64-0542	Ref: U3,U11 IC CONVERTER A/D 8-BIT TLC542 SM	0	EA	.0	A	Y	1.000000
2	590	12-64-4221	Ref: U21 IC CONVERTER A/D 20-BIT CS4221 SM	0	EA	.0	A	Y	1.000000

Ref: U18

2	610 15-62-0014	IC 74HC14 INVERTER-HEX SIN 1-IN SM	0 EA	.0	A Y	2.000000
		Ref: U4,U23				
2	620 15-62-0573	IC 74HC573 BUFFER INVERTING 8-BIT SM	0 EA	.0	A Y	1.000000
		Ref: U9				
2	630 15-62-0594	IC, Octal Shift Register SN74HC594DW	0 EA	.0	A Y	1.000000
		Ref: U22				
2	640 15-62-4051	IC, 8 to 1 Analog 74HC4051D	0 EA	.0	A Y	1.000000
		Ref: U16				
2	650 15-70-6256	DRAM FLEXTONE ISSI P/N IS4IC16257-35K	0 EA	.0	A Y	1.000000
		Ref: U15				
2	660 15-78-1024	IC EEPROM 1K (45AF751E)	0 EA	.0	A Y	1.000000
		Ref: U5				
2	670 15-84-8032	IC, Microprocessor 8032SMT P80C32SBBB Surface Mount	0 EA	.0	A Y	1.000000
		Ref: U10				
2	680 15-86-7070	IC DSP TMS57070FFT SM	0 EA	.0	A Y	1.000000
		Ref: U8				
2	690 15-92-1812	RESET CHIP DS1812R-5/T&R	0 EA	.0	A Y	1.000000
		Ref: U12				
2	700 21-00-4420	JACK 1/4" EARTHING-WASHER JB0661-K01-3	0 EA	.0	A Y	2.000000
		Ref: M10-11				
2	710 21-00-6616	JACK 1/4" STEREO FEMALE PCB-MN 6-PIN FLUSH	0 EA	.0	A Y	2.000000
		Ref: J2-3				
2	720 21-16-0045	JACK RJ-45 8-PIN FEMALE PCB-MNT RT-ANG	0 EA	.0	A Y	1.000000
		Ref: J1				
2	730 21-18-0250	Connector, Qck.ConnectPost .250 Amp 63824-1	0 EA	.0	A Y	9.000000
		Ref: M1-9				
2	740 21-23-1301	HEADER, 24 PIN 0.1" RIBBON	0 EA	.0	A Y	1.000000

Amp#104338-5

Ref: H1

2 750 21-42-0028 SOCKET 28 pin TH 0 EA .0 A Y 1.000000

Ref: for U13

2 755 24-19-4025 FUSE 4A 125v 0 EA .0 A Y 1.000000
Littlefuse# H239 004 or equiv.

1 510 50-00-2212 Cabinet, Spider 0212 0 EA .0 A Y 1.000000

2 10 30-00-0621 SCR WD 6-18 x 1 1/4 LG PHILLIP 0 EA .0 A Y 2.000000
S RND HD STL BLK OXIDE

2 20 30-00-0812 SCR NO.8 x 3/4 LG PHH TRUSS BL 0 EA .0 A Y 14.000000
K OXIDE W/WAX (CORNER)

2 30 30-00-1024 SCR, 10-24 x 1.0 LG, OVAL CTSK 0 EA .0 A Y 2.000000
, PHH, STL, BLK OXIDE, WAXED

2 40 30-28-0002 CORNER, LEFT, PLASTIC (SPIDER 0 EA .0 A Y 1.000000
)

2 50 30-28-0003 Plastic right corner-Spider 0 EA .0 A Y 1.000000

2 60 30-28-0004 CORNER, REGULAR, PLASTIC (SPI 0 EA .0 A Y 6.000000
DER)

2 70 30-36-0001 FABRIC VINYL BLACK-BRONCO 0 YD .0 A Y .750000
ASC03 54"-Wide

2 80 30-39-0001 FAB Grille Black #BY4584-22 0 YD .0 A Y .166000
50 Yard Rolls

2 90 30-57-0580 HANDLE/STRAP 0 EA .0 A Y 1.000000
Heavy Duty, Black

2 100 30-57-0581 END CAPS, BLACK, TEXTURED FINI 0 EA .0 A Y 2.000000
SH



Service Dept.

6033 De Soto Ave.

Woodland Hills, CA 91367

P. 818-575-3600

F. 818-676-1585

E. service@line6.com

Procedure for reinitialization of Spider amps (Hard reset)

Power unit up while holding down the “A” button. Hold for 3 seconds and then release. Factory presets will be re-installed.

Procedure for identifying firmware version of Spider amps

Power unit up while holding down the “B” button. The display will show the following info for approximately 2 seconds:

Version 1.1 = “Clean” and “D” LEDs will light up.

Version 1.2 = “Clean” and “C” LEDs will light up.

Version 1.3 = “Clean”, “C” and “D” LEDs will light up.

The MAJOR VERSION will be displayed on the Amp Select LEDs.

Version 1 = CLEAN LED: Version 2 = BLUES LED...Version 6 = SCREAM LED

The MINOR VERSION (0-15) will be displayed on the Channel LEDs in binary form. The LS bit is right justified.

If this is a BETA VERSION, the Tape Echo LED will light up.

SPIDER 212 TEST INSTRUCTIONS

Rev.0

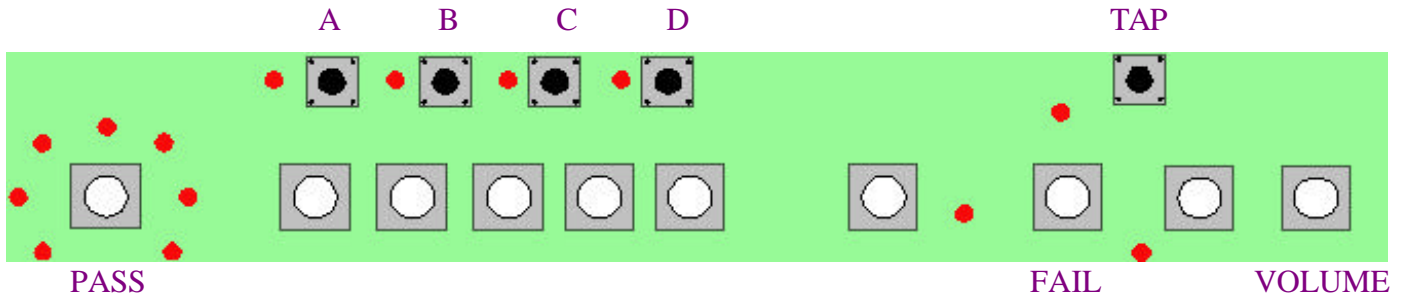

TEST SETUP/INSTRUCTIONS:

1. Place SPIDER 212 test boards on mounting pegs. Make sure the **POWER** (red button on the back panel) is OFF, and connect all the cables to the test fixture and SPIDER 212 test boards (Note numbers).
2. Hold down the **TAP** button while turning on **POWER** (red button on the back panel), the **D** Channel LED will be lit.
3. Flip the **AUDIO SELECTOR** switch to **SPEAKER**.
4. Unplug the **HEADPHONE** cable (4) from the front PCB (the **SPEAKER** output is muted when the **HEADPHONE** input (4) is plugged in).
5. Adjust the **VOLUME** pot on the SPIDER 212 test board until the yellow **VOLUME** LED on the test fixture lights.
6. Put on the headphones and listen (adjust the headphone volume on the test fixture if necessary): the tone (audible signal) should be clean and heard equally on both sides.
7. Plug in the **HEADPHONE** cable (4) into the SPIDER 212 test board **HEADPHONE** input (4). The sound in the headphones should be muted and the yellow **VOLUME** LED on the test fixture should go out.
8. Flip the **AUDIO SELECTOR** switch to **HEADPHONE** and listen: the tone (audible signal) should be clean and heard equally on both sides.
9. ADC/DRAM TEST - Press the button labeled **AUDIO ATTENUATE** (on test fixture) and you should hear the signal get softer (smaller) on one side and then the other. If the signal doesn't get softer (or goes off) the ADC Test fails. If the signal gets softer on both sides of the headphones at the same exact time, the DRAM Test fails.
10. Press each **CHANNEL BUTTON: A, B, C, D** to test the switches, the **B, C & D** LEDs should change.
11. Start Test 0001 (only LED **D** lighted). See SPIDER 212 TEST DESCRIPTIONS (TABLE 1) for Test summary.
12. Press **TAP** to start Test 0001. This is a **PASS/FAIL** test: the 6 LEDs on left will light for a **PASS**
the 3 LEDs on the right will light up for a **FAIL**
13. Press any **CHANNEL BUTTON** and then the **TAP** button to start Test 0010. This is a **PASS/FAIL** test.
14. Press any **CHANNEL BUTTON** and then the **TAP** button to start Test 0011. All LEDs should light evenly.

15. Press any **CHANNEL BUTTON** and then the **TAP** button to start Test 0100.
 On the SPIDER 212 test board:
- LEDs **A, B, & C** should be lighted
 - Rotate the pots: the **PASS** LEDs should light up as the pot is rotated
 - Unplug and Plug in **HEADPHONE**: LED **A** should turn OFF then ON
 - Unplug and Plug in **TEST SIGNAL**: LED **C** should turn OFF then ON
16. Press any **CHANNEL BUTTON** and then the **TAP** button to start Test 0101. This is a **PASS/FAIL** test. On the test fixture the 4 red LEDs (**VCC1, VCC2, GND1 & GND2**) should be lighted and the green **SERIAL** LED should blink 3 times.

TABLE 1

SPIDER 212 TEST DESCRIPTIONS:

<u>A</u>	<u>B</u>	<u>C</u>	<u>D</u>	<u>Test</u>	<u>Result</u>
0	0	0	1	EPROM	<u>PASS</u> or <u>FAIL</u>
0	0	1	0	EEPROM	<u>PASS</u> or <u>FAIL</u>
0	0	1	1	LED	All LEDs light evenly
0	1	0	0	POTS/JACKS	<u>ROTATE</u> pots = LEDs rotate, <u>UNPLUG</u> and <u>PLUG</u> in Headphone jack = LED A will turn ON and OFF. <u>UNPLUG</u> and <u>PLUG</u> in Test Input jack = LED C will turn ON and OFF.
0	1	0	1	RJ-45	<u>PASS</u> or <u>FAIL</u> , Test fixture: 4 red LEDs light and green flashes 3 times

To enter Test Mode:

Hold Tap Tempo while turning the power on. When Test Mode is successfully entered only the Channel D LED will light. This indicates that test #1 is ready to execute. To scroll through the available tests any Channel button A-D can be pressed. This will increment the test number by one. The test number is displayed in binary form on the Channel LEDs. When the last test is reached and any of the Channel buttons is pressed the test number wraps around to the beginning again. To execute a test press the Tap Tempo button. Most tests will display a pass or fail indication. The pass indication is all six of the LEDs surrounding the Amp Select knob light up. The fail indication is all three of the LEDs surrounding the Delay Select knob light up. See below for descriptions of the individual tests.

Individual Test Description:

The tests according to binary number displayed:

1. EPROM Test – Channel D LED is lit
The test will indicate pass or fail as described above when it finishes. The EPROM test consists of summing up the individual bytes values starting at address zero of the EPROM and comparing it to the 16 bit stored value in the last two bytes of the EPROM. If the test fails it can be a result of:
 - a. A misprogrammed EPROM.
 - b. A faulty EPROM.
 - c. Microprocessor address line shorts or bad connections.
 - d. Microprocessor data line shorts or bad connections.

2. EEPROM Test – Channel C LED is lit
The test will indicate pass or fail as described above when it finishes. The EEPROM test consists of writing an alternating checkerboard bit pattern to each 16-bit word in the EEPROM to check for bit failure. The test is non-destructive. If the test fails it can be a result of:
 - a. Microprocessor control line shorts or bad connections.
 - b. A faulty EEPROM.

3. LED Test – Channel D & C LEDs are lit
This test does not indicate pass or fail. The LEDs must be visually inspected to determine pass or fail status. All LEDs light for approximately 2 seconds, are then turned off and each LED individually lit for approximately 500 milliseconds (1/2 second). The test fails when a LED does not light when supposed to or a LED lights when it is not supposed to. The test also fails when a LED flickers. If the test fails it can be a result of:
 - a. A faulty LED (does not turn on when supposed to).
 - b. A bad connection (flickers or does not turn on when supposed to).
 - c. A short (LED is on when not supposed to be).

4. Analog to Digital Converter Potentiometer & Switch Test – Channel B LED is lit
This test does not indicate pass or fail. The Pots and Switches must be visually inspected to determine pass or fail status. To test a knob turn it through its full range of values and make sure the LEDs surrounding the Amp Select knob follow correspondingly. Make sure each of the six LEDs lights over the full range. Repeat for each knob. The test fails if any of the six LEDs do not light when the knob is checked through its full range. In addition, the test fails if the LED sequence is not sequential or it flickers. To test switches plug/unplug the headphone and the Channel A LED will turn on/off. The Channel B LED on/off status reflects the stereo/mono resistor setting. The Channel C LED on/off status reflects the guitar input jack plug/unplug status. If the test fails it can be a result of:
 - a. A faulty LED (hopefully you did the LED test before getting to this one).
 - b. A bad connection (LED flickers or doesn't move when knob range or switch checked).
 - c. A bad potentiometer (LED flickers or doesn't move when knob range checked).
 - d. A bad A/D converter (LED doesn't move when knob range checked).

5. Remote Test – Channel B & D LEDs are lit
The test will indicate pass or fail as described above when it finishes for only part of the test. The automatic part of the test checks the A/D pedal values and determines whether it passes or fails. To check the serial communication the remote LED on the test fixture will blink 3 times. This part of the test does not indicate pass or fail and must be visually inspected to determine pass or fail status. If the test fails it can be a result of:
 - a. A bad connection.
 - b. A bad A/D converter.
 - c. A bad Microprocessor serial port (LED doesn't blink).
 - d. A bad Microprocessor connection (LED doesn't blink).

6. Audio Test – can be done any time during Test Mode. The main volume knob is active and works like normal except during the Potentiometer test.

Spider Software Version number:

Press and hold Channel B button while turning on. The display will show the following info for approximately 2 seconds:

The MAJOR VERSION will be displayed on the Amp Select LEDs.

Version 1 = CLEAN LED; Version 2 = BLUES LED ... Version 6 = SCREAM LED

The MINOR VERSION (0 – 15) will be displayed on the Channel LEDs in binary form. The LS bit is right justified.

Spider Default initialization:

Press and hold the Channel A button while turning on.